

HIGH VOLTAGE IGNITION COIL DRIVER POWER IC

TYPE	V _{clamp}	I _{cl}	I _{lim}
VB027BSP	420 V	10.5 A	160 mA

- PRIMARY COIL VOLTAGE INTERNALLY SET
- COIL CURRENT LIMIT INTERNALLY SET
- LOGIC LEVEL COMPATIBLE INPUT
- DRIVING CURRENT QUASI PROPORTIONAL TO COLLECTOR CURRENT
- DOUBLE FLAG-ON COIL CURRENT

DESCRIPTION

The VB027BSP is a high voltage power integrated circuits made using SGS-THOMSON Microelectronics Vertical Intelligent Power Technology, with vertical current flow power darlington and logic level compatible driving circuits.

Built-in protection circuits for coil current limiting and collector voltage clamping allows the VB027BSP to be used as a smart, high voltage, high current interface in advanced electronic ignition systems.

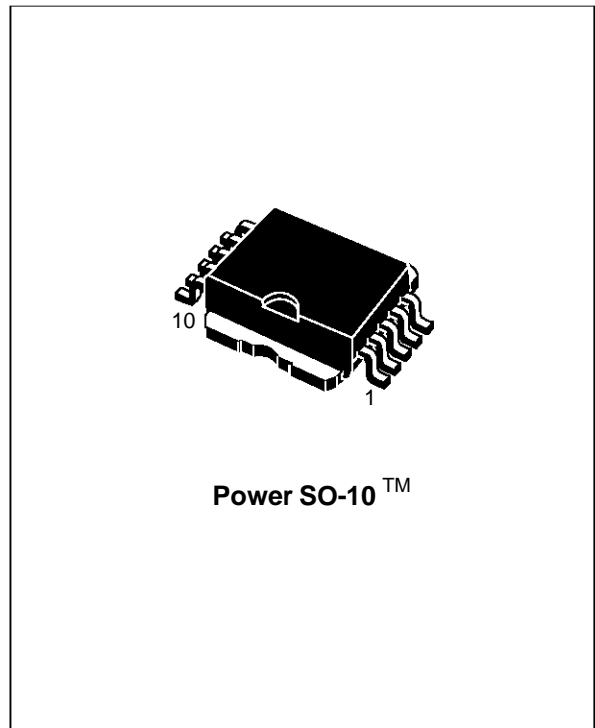

BLOCK DIAGRAM

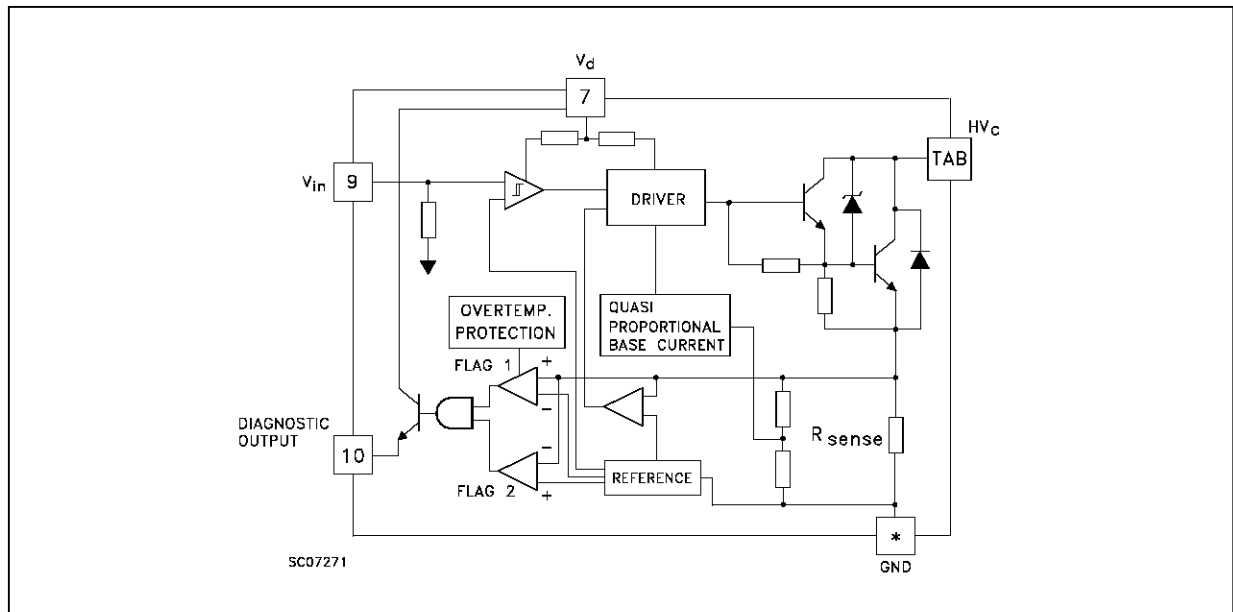

* Pins 1-5 = Power GND, Pin 6 signal GND. Pin 6 must be connected to pins 1-5 externally.

VB027BSP

ABSOLUTE MAXIMUM RATING

Symbol	Parameter	Value	Unit
HV_C	Collector Voltage	Internally Limited	V
I_C	Collector Current	Internally Limited	A
V_d	Driving Stage Supply Voltage	7	V
I_d	Driving Circuitry Supply Current	200	mA
V_{in}	Maximum Input Voltage	10	V
T_j	Operating Junction Temperature	-40 to 150	°C
T_{stg}	Storage Temperature Range	-55 to 150	°C

THERMAL DATA

$R_{thj-case}$	Thermal Resistance Junction Case(MAX)	1.12	°C/W
$R_{thj-amb}$	Thermal Resistance Junction Ambient(MAX)	62.5	°C/W

CONNECTION DIAGRAM

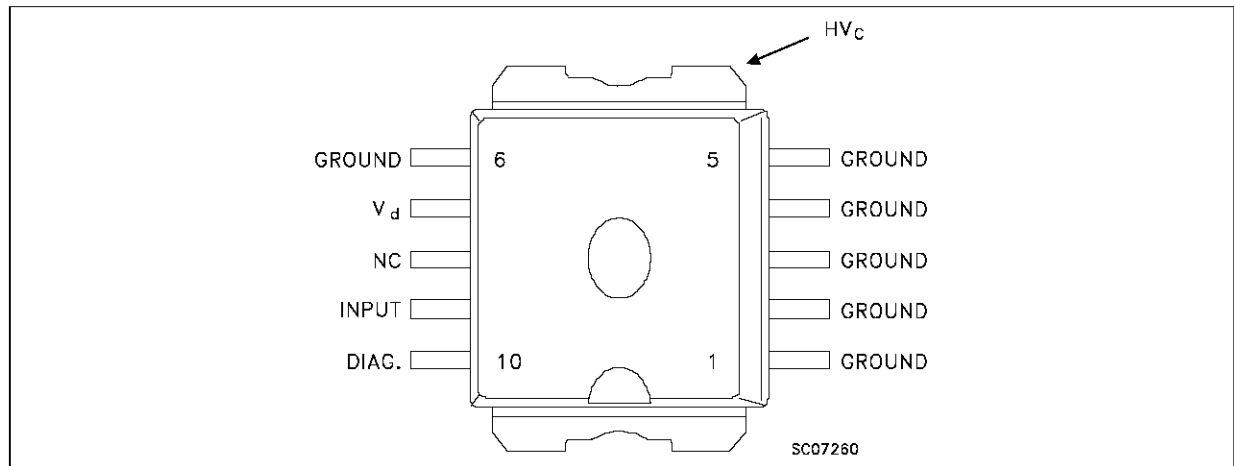

PIN FUNCTION

No	NAME	FUNCTION
1 - 5	GND	Emitter Power Ground
6 (*)	GND	Control Ground
7	V_d	Supply Voltage For The Power Stage
TAB	HV_C	Output to The Primary Coil
9	INPUT	
10	DIAGNOSTIC	Output of a Logic Signal When I_C Is Greater Than 3 A

(*) PIN 6 must be connected to PINS 1 - 5 externally

ELECTRICAL CHARACTERISTICS ($V_b = 13.5\text{ V}$; $V_d = 5\text{ V}$; $T_j = 25\text{ }^\circ\text{C}$; $R_{\text{coil}} = 510\text{ m}\Omega$;
 $L_{\text{coil}} = 7\text{ mH}$; unless otherwise specified)

Symbol	Parameter	Test Conditions	Min.	Typ.	Max.	Unit
V_{cl}	High Voltage Clamp	$-40^\circ\text{C} \leq T_j \leq 125\text{ }^\circ\text{C}$ $I_{\text{coil}} = 6\text{ A}$	320		420	V
$V_{\text{ce(sat)}}$	Saturation Voltage of The Power Stage	$I_c = 6\text{ A}$; $V_{\text{in}} = 4\text{ V}$ $-40^\circ\text{C} \leq T_j \leq 125\text{ }^\circ\text{C}$			2	V
$I_{\text{d(stdby)}}$	Stand-by Supply Current	$V_{\text{in}} = 0.4$			11	mA
$I_{\text{d(on)}}$	Power On Supply Current	$V_{\text{in}} = 4\text{ V}$ $I_c = 6\text{ A}$ $-40^\circ\text{C} \leq T_j \leq 125\text{ }^\circ\text{C}$			160	mA
V_d	Driver Stage Supply Voltage		4.5		5.5	V
I_{cl}	Coil Current Limit	$V_{\text{in}} = 4\text{ V}$	8.5		10.5	A
$I_{\text{cl(td)}}$	Coil Current Limit Drift With Temperature	See figure 3				
I_{leak}	Collector Leakage Current	$V_c = 125\text{ V}$			100	μA
V_{inH}	High Level Input Voltage		4		5.5	V
V_{inL}	Low Level Input Voltage		0		0.8	V
I_{inH}	High Level Input Current				200	μA
V_{diagH}	High Level Diagnostic Output Voltage	$R_{\text{EXT}} = 15\text{ k}\Omega$ $C_{\text{EXT}} = 1\text{ nF}$ (see fig. 1)	3.5		V_d	V
V_{diagL}	Low Level Diagnostic Output Voltage	$R_{\text{EXT}} = 15\text{ k}\Omega$ $C_{\text{EXT}} = 1\text{ nF}$ (see fig. 1)			0.5	V
I_{diagTH1}	Diagnostic Current First Threshold		4.25	4.5	4.75	A
I_{diagTD1}	Diagnostic Current First Threshold Drift With Temperature	See figure 4				
I_{diagTH2}	Diagnostic Current Second Threshold		5.45	5.8	6.15	A
I_{diagTD2}	Diagnostic Current Second Threshold Drift With Temperature	See figure 5				
I_{diagH}	Overtemperature Diagnostic Current		2	2.6	3.2	A
t_{dlc}	Delay Time Coil Current	$I_c = 6\text{ A}$	5	25	45	μs
t_{flc}	Fall Time Coil Current	$I_c = 6\text{ A}$	2	8	15	μs
$E_{\text{s/b}}$	Inductive Energy		300			mJ
T_{int}	Temperature of Diagnostic Shift		130	150	170	$^\circ\text{C}$
T_{hys}	Thermal Hysteresis			30		$^\circ\text{C}$
V_F	Forward Voltage of The Body Diode	$I_c = -10\text{ A}$		3		V

PRINCIPLE OF OPERATION

The VB027BSP is mainly intended as a high voltage power switch device driven by a logic level input and interfaces directly to a high energy electronic ignition coil.

The input V_{in} of the VB027BSP is fed from a low power signal generated by an external controller that determines both dwell time and ignition point.

During V_{in} high ($\geq 4V$) the VB027BSP increases current in the coil to the desired, internally set current level.

After reaching this level, the coil current remains constant until the ignition point, that corresponds to the transition of V_{in} from high to low (typ. 1.9V threshold).

During the coil current switch-off, the primary voltage HV_c is clamped at an internally set value V_{cl} , typically 365V.

The transition from saturation to desaturation, coil current limiting phase, must have the ability to accommodate an overvoltage. A maximum overshoot of 20V is allowed.

THERMAL BEHAVIOUR

You can see in the block diagram of the VB027BSP a box called overtemperature protection. The purpose of this circuit is to shift the current level at which the 1st diagnostic is activated down of about 2.5A.

This information can be managed by the micro that can take the corrective actions in order to reduce the power dissipation.

This block is not an effective protection but just

an overtemperature detection. The shift down of the 1st flag level cannot be present for temperatures lower than 125 °C.

As an example of its behaviour you can suppose a very simple motor management system in which the micro does just a simple arithmetic calculation to decide when to switch off the device after the 1st flag threshold.

EXAMPLE:

Iflag info after X msec. (Iflag = 4.5A)

Iswitch off after $K \cdot X$ msec.

As soon as the temperature rises over the overtemp. threshold, the 1st diagnostic is shifted down to about 2.5A and in this example, the switch off current will be $K \cdot X \cdot 2.5 / 4.5$ helping the system to reduce the power dissipation.

As you can see this behaviour is not a protection but just a feedback for the micro.

FEEDBACK

When the collector current exceeds 4.5A, the feedback signal is turned high and it remains so, until the load current reaches 5.8A (second threshold), at that value, the feedback signal is turned low.

OVERVOLTAGE

The VB027BSP can withstand the following transients of the battery line:

-100V/2msec ($R_i = 10 \Omega$)

+100V/0.2msec ($R_i = 10 \Omega$)

+50V/400msec ($R_i = 4.2 \Omega$, with $V_{IN} = 3 V$)

FIGURE 1: Application Circuit

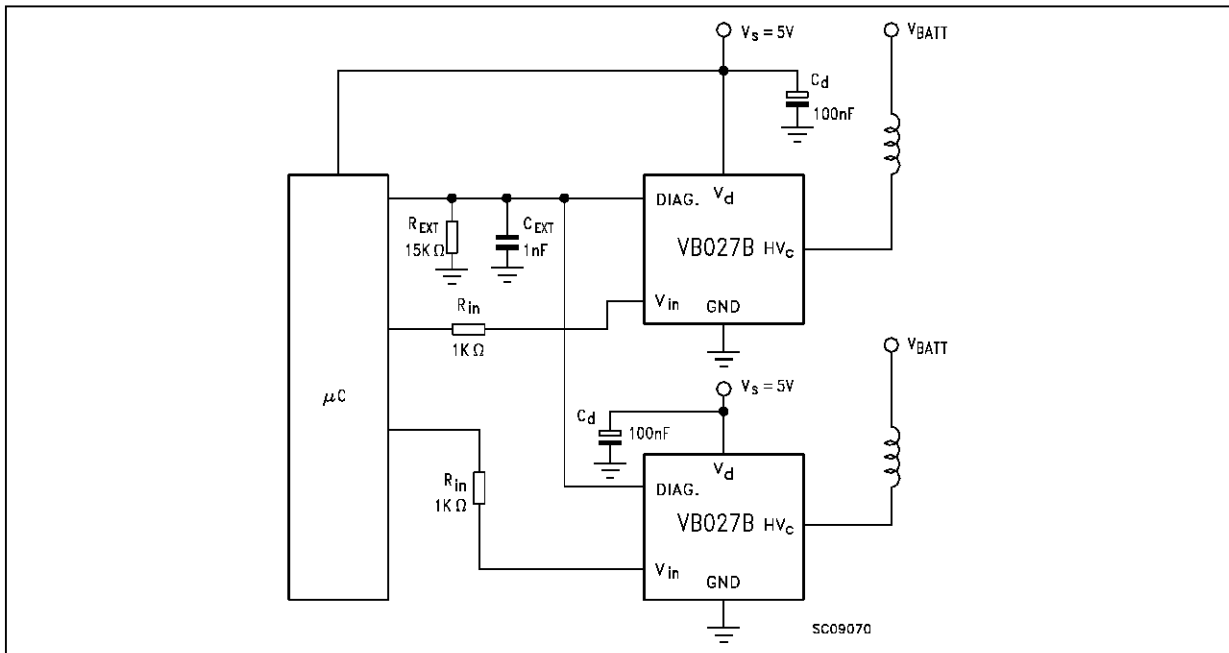

FIGURE 2: Switching Waveforms

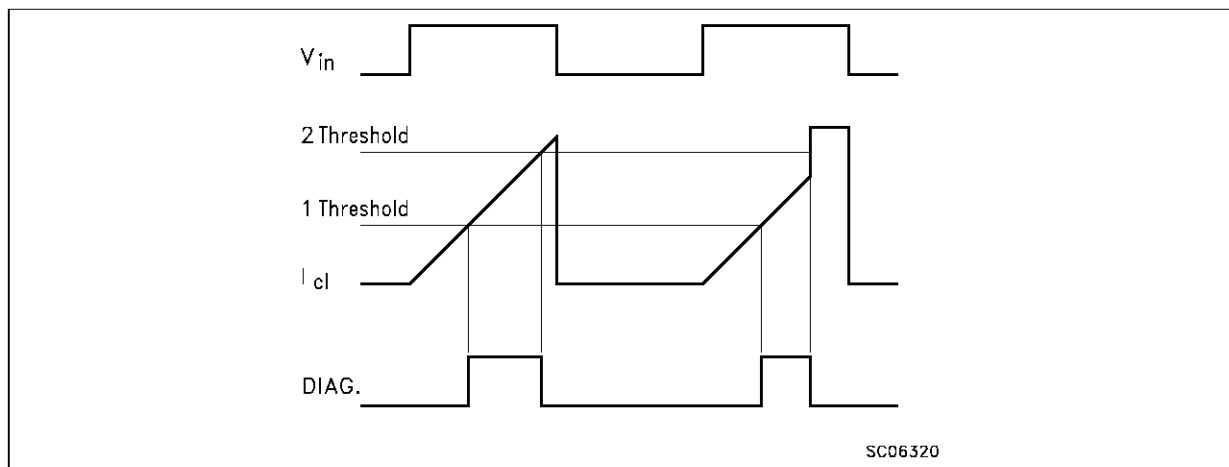

FIGURE 3: Maximum I_{cl} Versus Temperature

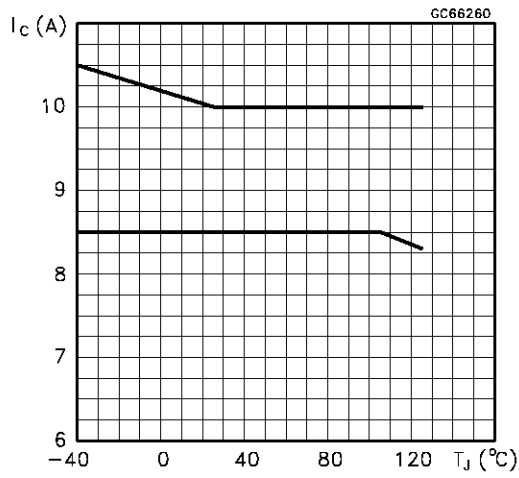

FIGURE 4: I_{flag1} Versus Temperature

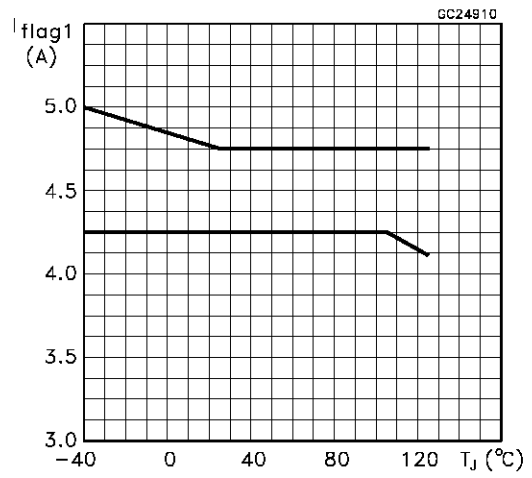
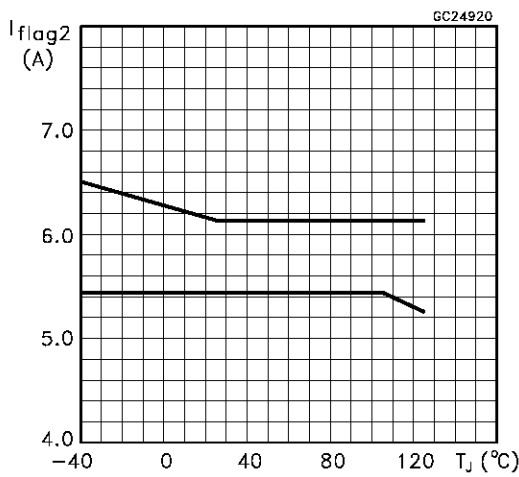
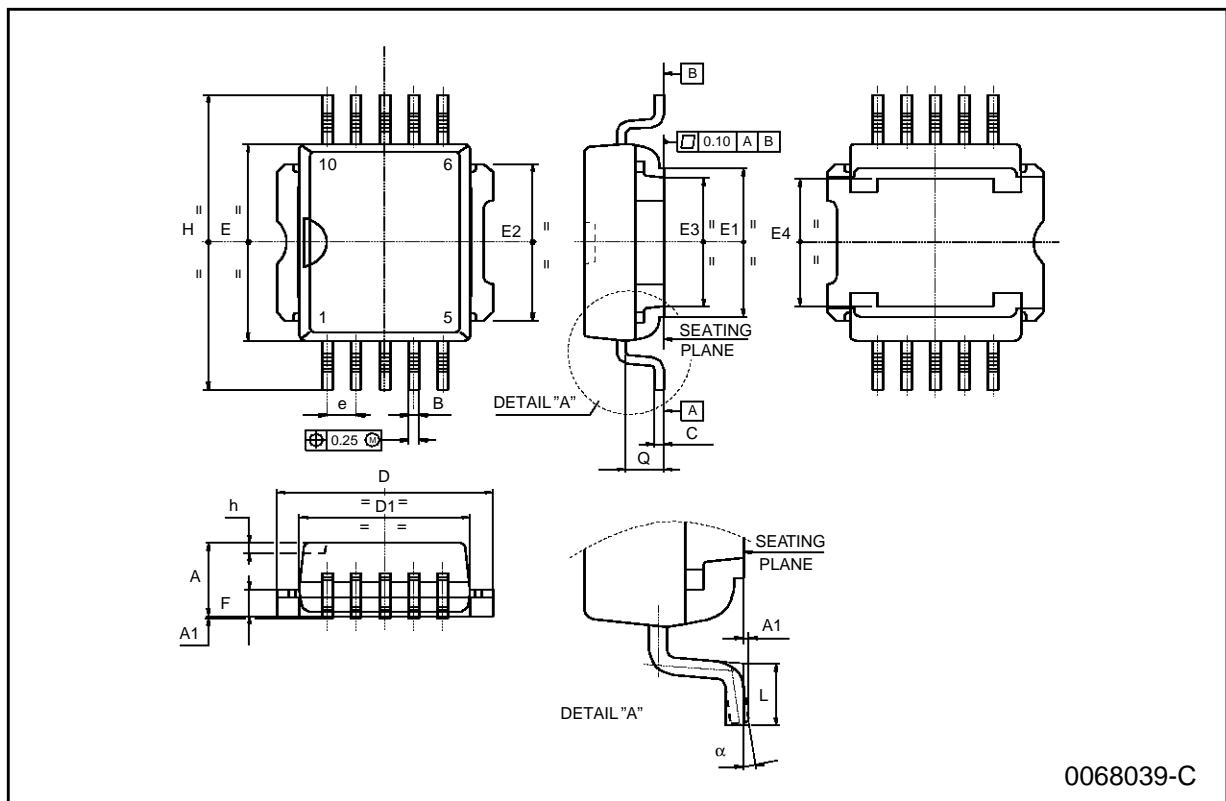

FIGURE 5: I_{flag2} Versus Temperature



Power SO-10 MECHANICAL DATA

DIM.	mm			inch		
	MIN.	TYP.	MAX.	MIN.	TYP.	MAX.
A	3.35		3.65	0.132		0.144
A1	0.00		0.10	0.000		0.004
B	0.40		0.60	0.016		0.024
c	0.35		0.55	0.013		0.022
D	9.40		9.60	0.370		0.378
D1	7.40		7.60	0.291		0.300
E	9.30		9.50	0.366		0.374
E1	7.20		7.40	0.283		0.291
E2	7.20		7.60	0.283		0.300
E3	6.10		6.35	0.240		0.250
E4	5.90		6.10	0.232		0.240
e		1.27			0.050	
F	1.25		1.35	0.049		0.053
H	13.80		14.40	0.543		0.567
h		0.50			0.002	
L	1.20		1.80	0.047		0.071
q		1.70			0.067	
α	0°		8°			



Information furnished is believed to be accurate and reliable. However, SGS-THOMSON Microelectronics assumes no responsibility for the consequences of use of such information nor for any infringement of patents or other rights of third parties which may result from its use. No license is granted by implication or otherwise under any patent or patent rights of SGS-THOMSON Microelectronics. Specifications mentioned in this publication are subject to change without notice. This publication supersedes and replaces all information previously supplied. SGS-THOMSON Microelectronics products are not authorized for use as critical components in life support devices or systems without express written approval of SGS-THOMSON Microelectronics.

© 1997 SGS-THOMSON Microelectronics - Printed in Italy - All Rights Reserved

SGS-THOMSON Microelectronics GROUP OF COMPANIES
Australia - Brazil - Canada - China - France - Germany - Hong Kong - Italy - Japan - Korea - Malaysia - Malta - Morocco - The Netherlands -
Singapore - Spain - Sweden - Switzerland - Taiwan - Thailand - United Kingdom - U.S.A
...