

Hazard Warning and Car Direction Indicator

Description

Its design is mainly based on the good results of U6043B in terms of EMC (Electro Magnetic Capability) and protection features. U6433B contains an additional 8-mV comparator and a logical connection with the frequency doubling stage. This combination can be used

for a hazard switch which bypasses the external shunt resistor to disable the frequency doubling. This feature is a request of the US automotive industry. During direction mode U6433B works like other flashers, i.e., frequency doubling in the case of lamp outage.

Features

- Temperature and voltage compensated frequency
- Warning indication of lamp failure by means of frequency doubling can be disabled
- Voltage dependence of the car indicator lamps compensated for lamp failure
- Relay output with high current carrying capacity and low saturation voltage
- Lamp load ≥ 1 W
- Load-dump protection
- RF protected
- Damage and interference protection with a minimum of external components

Benefits

U6433B gives an easy access to more flasher applications in the US automotive market

Block diagram

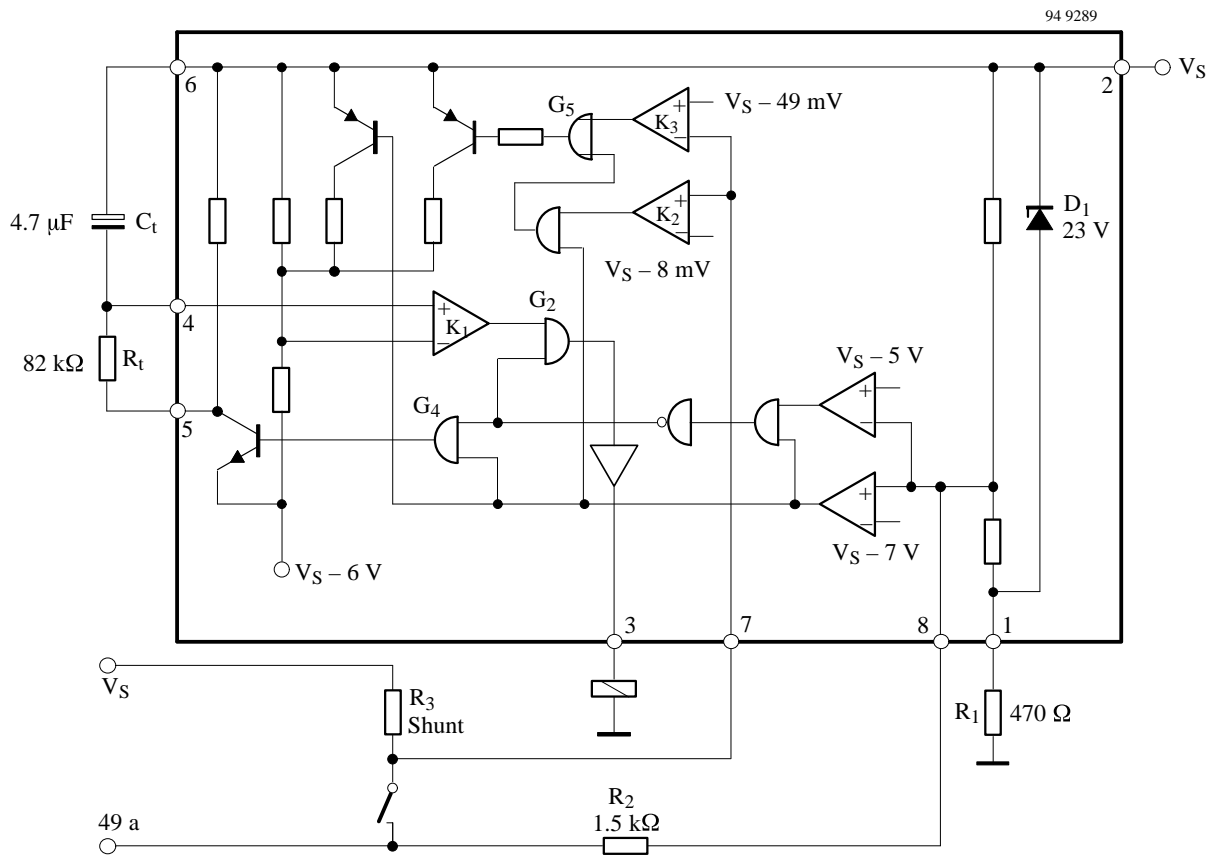
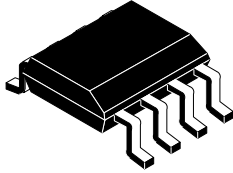

Figure 1 The U6433B-FP in an application circuit

U6433B-FP

Package

8-pin SO plastic



SO 8

Circuit Description

The application circuit shows the operation of the U6433B-FP as a car direction indicator signal generator. The flashing frequency is determined by the components R_t and C_t , and the frequency can be calculated from

$$f_1 \sim \frac{1}{R_t \cdot C_t \cdot 1.5} \text{ (Hz)}$$

where f_1 is the frequency in normal flashing operation (basic frequency). The control frequency, f_2 , is typically 2.2 times the value of f_1 and is the frequency in the case of lamp failure. The bright periods for f_1 and f_2 are internally set in the IC and are 50% for f_1 and 40% for f_2 .

The resistors R_1 and R_2 are needed to protect the circuit against possible damage. An integrated protection circuit, together with these external resistors, limits the impulse current in the integrated circuit.

Protection in the case of battery reversal: The resistors R_1 , R_2 and the relay coil limit the currents so the integrated circuit will not be damaged. To achieve a protection for continuous battery reversal, resistor R_1 should be capable of 30 mA (0.5 W type).

A short circuit between indicator lamp (49a) and ground (31) can give rise to a voltage drop of about 4 V across the measuring resistance R_3 . In this case, the integrated circuit would not be damaged.

The use of the application circuit (figure 1) ensures damage and interference protection consistent with ISO/TR 7637/1 and load dump.

Control Signal Threshold 1 (49-mV Comparator)

The detection point for lamp failure can be calculated from the control signal threshold, typically 49 mV with $V_S = 12$ V. With a measuring resistance of $R_3 = 18$ m Ω , the frequency changeover is reached at a lamp load of 21 W + 11.4 W. The variation of the control signal threshold supply voltage takes into account the PTC characteristic of filament lamps.

Control Signal Threshold 2 (8-mV Comparator)

A voltage drop at R_3 between 49 mV and 8 mV shunt resistor let the flasher work in frequency doubling mode.

If the voltage drop of $V_{R3MAX} = 8$ mV falls the frequency doubling is disabled. This can be achieved either with a switch which by passes the shunt resistor (e.g., a special hazard warning switch) or with a small lamp load.

The arrangement of the supply connections to Pins 2 and 6 must ensure that, on the connection, PCB, the layer resistance from V_S to Pin 6 is lower than the one to Pin 2.

Flasher operation starts with a lamp load of $P_L \geq 1$ W.

Pin Description

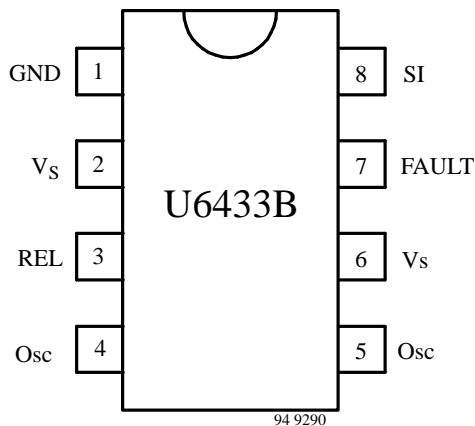

Pin	Symbol	Function
1	GND	IC ground
2	V _S	Supply voltage
3	REL	Relay driver
4	Osc	Oscillator
5	Osc	Oscillator
6	V _S	Supply voltage
7	FAULT	Lamp failure detection
8	SI	Start input (49a)

Absolute Maximum Ratings

Reference point pin 1

Parameters	Symbol	Value	Unit
Supply voltage Pins 2 and 6	V _S	18	V
Surge forward current t _p = 0.1 ms Pins 2 and 6 t _p = 300 ms Pins 2 and 6 t _p = 300 ms Pin 8	I _{FSM}	1.5 1.0 30.0	A A mA
Output current Pin 3	I _O	0.3	A
Power dissipation T _{amb} = 95°C DIP 8 SO 8 T _{amb} = 60°C DIP 8 SO 8	P _{tot}	420 340 690 560	mW
Junction temperature	T _j	150	°C
Ambient temperature range	T _{amb}	-40 to +105	°C
Storage temperature range	T _{stg}	-55 to +125	°C

Electrical Characteristics

$T_{amb} = 25^{\circ}\text{C}$

Typical values under normal operation of the application circuit shown in figure 1, $V_S = 12\text{ V}$ (Pins 2 and 6).

Reference point ground (-31), unless otherwise specified.

Parameters	Test conditions / Pin	Symbol	Min.	Typ.	Max.	Unit
Supply voltage range	Pins 2 and 6	V_S	9		16.5	V
Supply current, dark phase	Pins 2 and 6	I_S		4.5	8	mA
Supply current, bright phase	Pins 2 and 6	I_S		7.0	11	mA
Relay output, saturation voltage	$I_O = 150\text{ mA}$, $V_S = 9\text{ V}$ Pin 3	V_O			1.0	V
Relay output reverse current	Pin 3	I_O			0.1	mA
Relay coil resistance		R_L	60			Ω
Start delay	First bright phase	t_{on}			10	ms
Frequency determining resistor		R_t	6.8		510	k Ω
Frequency determining capacitor		C_t			47	μF
Frequency tolerance	Normal flashing, basic frequency f_1 not including the tolerances of the external components R_t and C_t	Δf_1	-5		+5	%
Bright period	Basic frequency f_1 , $V_S = 9 - 15\text{ V}$	Δf_1	47		53	%
Bright period	Control frequency f_2 , $V_S = 9 - 15\text{ V}$	Δf_2	37		45	%
Frequency increase	Lamp failure, $V_S = 9 - 15\text{ V}$	f_2	$2.15 f_1$		2.3	f_1
Control signal threshold 1	$V_S = 15\text{ V}$ $V_S = 9\text{ V}$ $V_S = 12\text{ V}$ Pin 7	V_{R3}	50 43 47	53 45 49	57 47 51	mV
Control signal threshold 2		V_{R3}	2		10	mV
Resistance between 49a to ground for standby		R_p			5	k Ω
Lamp load		P_L	1			W

Dimensions in mm

Package: SO 8

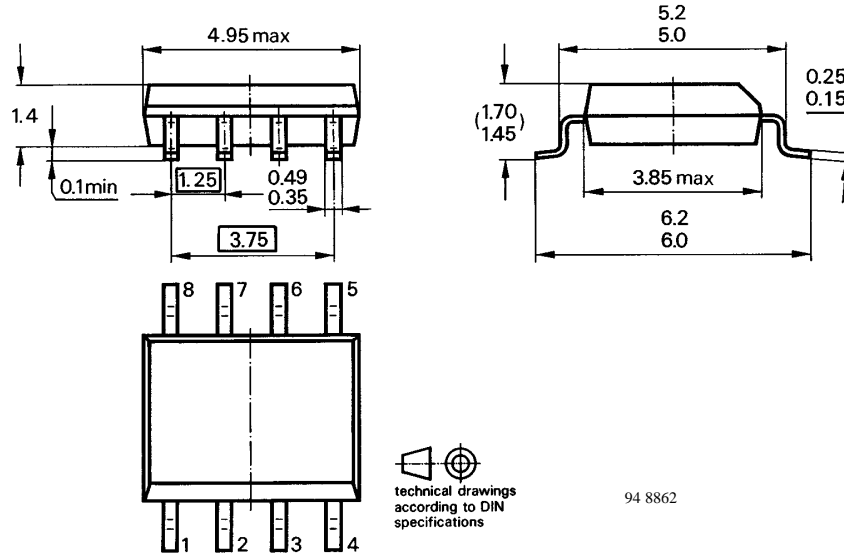

We reserve the right to make changes to improve technical design without further notice.

Parameters can vary in different applications. All operating parameters must be validated for each customer application by the customer. Should the buyer use TEMIC products for any unintended or unauthorized application, the buyer shall indemnify TEMIC against all claims, costs, damages, and expenses, arising out of, directly or indirectly, any claim of personal damage, injury or death associated with such unintended or unauthorized use.

TEMIC TELEFUNKEN microelectronic GmbH, P.O.B. 3535, D-74025 Heilbronn, Germany
 Telephone: 49 (0)7131 67 2831, Fax Number: 49 (0)7131 67 2423

OZONE DEPLETING SUBSTANCES POLICY STATEMENT

It is the policy of **TEMIC TELEFUNKEN microelectronic GmbH** to

1. Meet all present and future national and international statutory requirements and
2. Regularly and continuously improve the performance of our products, processes, distribution and operating systems with respect to their impact on the health and safety of our employees and the public, as well as their impact on the environment.

Of particular concern is the control or elimination of releases into the atmosphere of those substances which are known as ozone depleting substances (ODSs).

The Montreal Protocol (1987) and its London Amendments (1990) will soon severely restrict the use of ODSs and forbid their use within the next ten years. Various national and international initiatives are pressing for an earlier ban on these substances.

TEMIC TELEFUNKEN microelectronic GmbH semiconductor division has been able to use its policy of continuous improvements to eliminate the use of any ODSs listed in the following documents.

1. Annex A, B and list of transitional substances of the Montreal Protocol and the London Amendments respectively
2. Class I and II ozone depleting substances in the Clean Air Act Amendments of 1990 by the Environmental Protection Agency (EPA) in the USA and
3. Council Decision 88/540/EEC and 91/690/EEC Annex A, B and C (transitional substances) respectively.

TEMIC can certify that our semiconductors are not manufactured with and do not contain ozone depleting substances.