

Low-Current Superhet Remote Control Receiver

Description

The U4311B is a monolithic Integrated Circuit in bipolar technology for low-current UHF remote control super-heterodyne receivers in amplitude- or frequency-modulated mode. Typical applications are keyless car

lock-, alarm or telecontrol remote indication systems. Especially for automotive applications it supports a superhet design with about 1 mA total current consumption, as required by the car manufacturers.

Features

- Usable for amplitude- and frequency- modulated transmission systems
- Extremely low quiescent current approximately 1 mA in the stand-by mode due to wake-up concept
- Wide power supply voltage range 3 to 13 V
- Sensitive IF-amplifier for 10.7 MHz operating frequency
- Logarithmic AM demodulator
- FM demodulator
- Monoflop exit to wake up a microcontroller
- High performance operational amplifier to realize a data recovering filter
- Non-inverting clamping comparator with amplitude-dependent hysteresis for data regeneration

Block Diagram

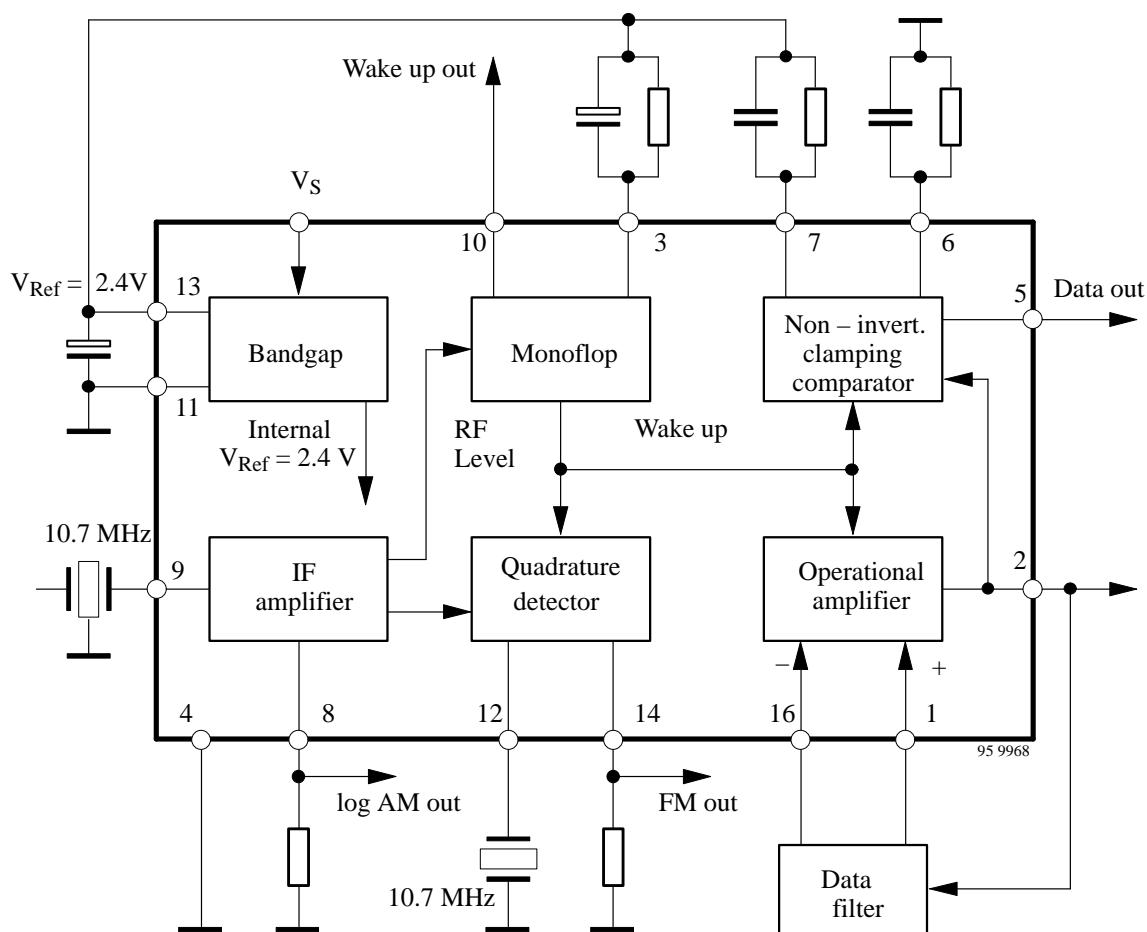

Figure 1. Block diagram

Pin Description

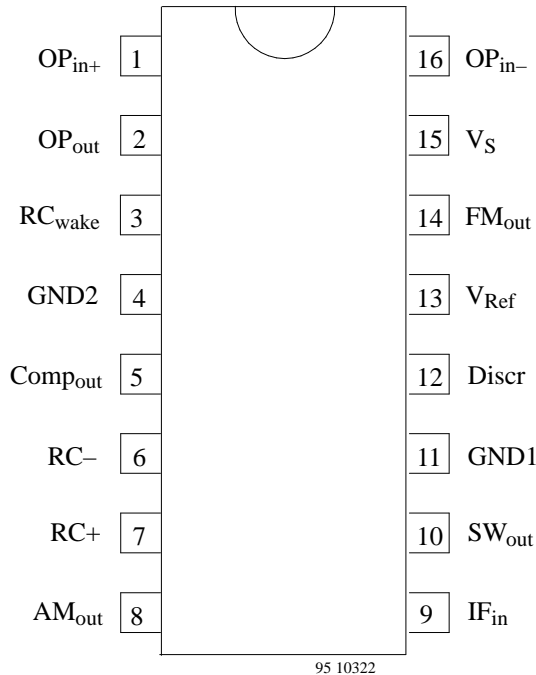

Figure 2. Pin description

Pin	Symbol	Function
1	OP _{in+}	OP amplifier non inverted input
2	OP _{out}	OP amplifier output
3	RC _{wake}	RC wake up reset time
4	GND2	Ground of the logical circuits
5	Comp _{out}	Comparator output
6	RC ₋	Comparator time constant
7	RC ₊	Comparator time constant
8	AM _{out}	AM current output
9	IF _{in}	IF input
10	SW _{out}	Wake up output
11	GND1	Ground of the analog circuits
12	Discr	FM discriminator tank
13	V _{ref}	Reference voltage
14	FM _{out}	FM discriminator output
15	V _S	Supply voltage
16	OP _{in-}	OP amplifier inverted input

Internal connections see figures 4 to 19

Absolute Maximum Ratings

Parameters	Symbol	Value	Unit
Supply voltage	V _S	13	V
Power dissipation T _{amb} = 85°C	P _{tot}	400	mW
Junction temperature	T _j	125	°C
Ambient temperature	T _{amb}	-40 to +85	°C
Storage temperature	T _{stg}	-55 to +125	°C

Thermal Resistance

Parameters	Symbol	Value	Unit	
Junction ambient	DIP16	R _{thJA}	120	K/W
	SO16L	R _{thJA}	100	K/W

Electrical Characteristics

$V_S = 5\text{ V}$, $T_{\text{amb}} = 25^\circ\text{C}$, $f_{\text{in}} = 10.7\text{ MHz}$; FM part: $f_{\text{mod}} = 1\text{ kHz}$, $f_{\text{dev}} = 22.5\text{ kHz}$; AM part: $f_{\text{mod}} = 1\text{ kHz}$, $m = 100\%$ unless otherwise specified

Parameters	Test Conditions / Pins	Symbol	Min.	Typ.	Max.	Unit
Characteristics						
Supply voltage range	Pin 15	V_S	3		12	V
Quiescent supply current	Pin 15	I_q		1	1.3	mA
Active supply current	Pin 15	I_{act}		2.8	3.6	mA
Bandgap						
Regulated voltage	Pin 13	V_{ref}	2.3	2.4	2.5	V
Output current	Pin 13	I_{ref}			5	mA
Source resistance	Pin 13	R_{ref}		2.3	5	Ω
External capacitor	Pin 13	C_{ref}	10			μF
Power supply rejection ratio	$f = 50\text{ Hz}$ Pin 13	psrr		60		dB
IF amplifier						
Input resistance	Pin 9	R_{in}	180	330	520	Ω
Input capacitance	Pin 9	C_{in}		5		pF
Typical internal 3 dB frequency	IF level 70 dB μV Pins 9 and 14	$f_{3\text{dB}}$	8		12	MHz
-3 dB limiting point	Pin 9	$V_{\text{FM}3\text{dB}}$		30		dB μV
Recovered data voltage	Pin 14	V_{FMout}	50	130	230	mV
FM detector output resistance	Pin 14	R_{FMout}		50		k Ω
AM rejection ratio	$m = 30\%$ Pins 9 and 14	AM_{rr}		25		dB
Maximum AM input voltage	Pin 9	V_{AMmax}		90		dB μV
AM quiescent current	Pin 8	I_{AMout}	10	22	37	μA
Maximum AM current	Pin 8	I_{AMoutmax}		100		μA
Operational amplifier						
Gain bandwidth product	Pins 1, 2 and 16	f_t	3	4	6.5	MHz
Excess phase	Pins 1, 2 and 16	δ		80		degree
Open loop gain	Pins 1, 2 and 16	g_0	50	70	95	dB
Output voltage range	Pin 2	ΔV_{out}		1.55		V
Common mode input voltage	Pins 1 and 16	V_{in}	0.7		1.7	V
Input offset voltage	Pins 1 and 16	V_{os}	-2.5	0	+2.5	mV
Maximum output current	Pin 2	I_{out}			5	mA
Common mode rejection ratio	Pin 1 and 16	cmrr	65	85		dB
Total harmonic distortion	$V_{\text{in}} < 300\text{ mV}$, $f = 33\text{ kHz}$, unity gain circuit Pin 2	thd		1	3	%
Power supply rejection ratio	$f = 50\text{ Hz}$ Pin 2	psrr	65	85		dB

Parameters	Test Conditions / Pins	Symbol	Min.	Typ.	Max.	Unit
Clamping comparator						
Typical common mode input voltage range	Pin 2	V_{cmvr}	0.8		1.6	V
Maximum distortion voltage	$V_{signal} = 100 \text{ mV}$, $R_+ = R_- = 50 \text{ k}\Omega$, $C_+ = C_- = 200 \text{ nF}$, $f_{disto} = 50 \text{ Hz}$, $f_{signal} = 1 \text{ kHz}$ Pin 2	V_{dmax}			200	mV
Output voltage	$V_2 > (V_6 + V_7) / 2$ (10 k Ω load to V_{Ref}) Pin 5	V_{cout}		V_{Ref}		1)
Output voltage	$V_2 < (V_6 + V_7) / 2$ (10 k Ω load to V_{Ref}) Pin 5	V_{cout}	0	150	250	mV
Wake up circuit						
Minimum wake up level	Pin 9	V_{in}		40		dB μ V ²⁾
Internal charging resistor	Pin 3	R_{int}		1.5		k Ω
Threshold voltage	Pin 3	V_{th}		1.6		V
Output switch current	Pin 10	I_{SW}	180	250	550	μ A
Output switch voltage	Pin 10	V_{SW}			5.5	V ³⁾
External wake up resistor	Pins 3 and 13	R_{WU}	22			k Ω
External wake up capacitor	Pins 3 and 13	C_{WU}			10	μ F
Hold time ($\pm 30\%$)		t_h	$\approx 1.5 \times R_{WU} \times C_{WU}$			s ⁴⁾
Delay time ($\pm 30\%$)		t_d	$\approx C_{WU} \times 0.75 \text{ k}\Omega$			s ⁴⁾

- 1) IC version with inverting comparator available: U4313B
- 2) Measured at Pin 9, referred to 330 Ω
- 3) Protected by a Z-diode, see figure 13
- 4) Valid for $0.1 \mu\text{F} \leq C_{WU} \leq 10 \mu\text{F}$ and $22 \text{ k}\Omega \leq R_{WU} \leq 680 \text{ k}\Omega$

Application

The U4311B is well-suited to implement UHF remote control or data transmission systems, based on a low-current superheterodyne receiver concept. SAW-devices may be used in the transmitter as well as in the receiver local oscillator. The front end should be a discrete circuit application with low current UHF-transistors like S822T or S852T from TEMIC TELEFUNKEN microelectronic GmbH. The frequency of the local oscillator can be determined either by coaxial resonators or SAW-devices. Due to large SAW-resonator tolerance an IF-bandwidth – and

in a FM-system additionally the discriminator amplitude characteristic (figure 28) – of 300 kHz or higher is proposed. As the circuit needs only 3.0 V supply voltage for operation the front end may be a stacked design in order to achieve a total receiver current consumption of approximately 1 mA. Figure 29 shows a principle receiver concept diagram. The application notes ANT012, ANT013, and ANT015 contain more detailed information on complete RF links.

Circuit Description

General functions

The integrated circuit U4311B includes the following functions: IF-amplifier, FM-demodulator, wake-up circuit with monoflop, operational-amplifier, non-inverting data comparator and voltage-regulator.

The 10.7 MHz IF-signal from the front end passes the integrated IF-amplifier which operates for amplitude- or frequency-modulated signals to either a logarithmic AM-demodulator which was implemented to avoid settling time problems effected by use of an automatic gain control system or a quadrature detector for FM. A data shaping filter – advantageously realized with the internal high performance operational-amplifier – reduces system bandwidth to an optimized compromise regarding transmission distance and data recognition. Thus, an optimal bit error rate can be achieved without any further active component.

The comparator connected to the output of the filter has a level-dependent hysteresis and clamps its reference voltage to the signal minimum and maximum peaks as described later.

Without IF-input signal – in the normal mode – only the IF-amplifier and the AM demodulator which operates as a level strength indicator are activated. If the level of the IF signal increases, the whole circuitry is turned on by the wake-up circuit. This signal is externally available at

pin 10 and can be used to wake up a microcontroller. After an adjustable reset time, determined by the monoflop time constant, the integrated circuit rests down to the sleep mode. In this case typically 1 mA supply current is required. An external resistor matched at pin 3 to ground blocks the wake-up circuit and gives fully function at lower IF-level as to recognize in figures 24 and 27, but supply current increases up to typically 2.8 mA.

Function of the clamping comparator

The output signal of the operational amplifier is fed to the input of the non-inverting comparator and two peak detectors (Q1 and Q2, figure 3). Their time constants are distinguished by RC+ and RC-. The components value must be adapted to the transmission code. The time constant should be large compared to the bit-rate for optimized noise and hum suppression. To compensate the input transistors base-emitter-voltage differences these two signals are buffered by Q3 and Q4. The mean value is used as comparator threshold, the difference of the peak values controls the hysteresis. This clamping comparator works as a data regenerator.

Another version of the IC, with an inverting clamping comparator, is also available (U4313B). Therefore the operational amplifier can be used either as a non-inverting or an inverting filter without the need of any additional components.

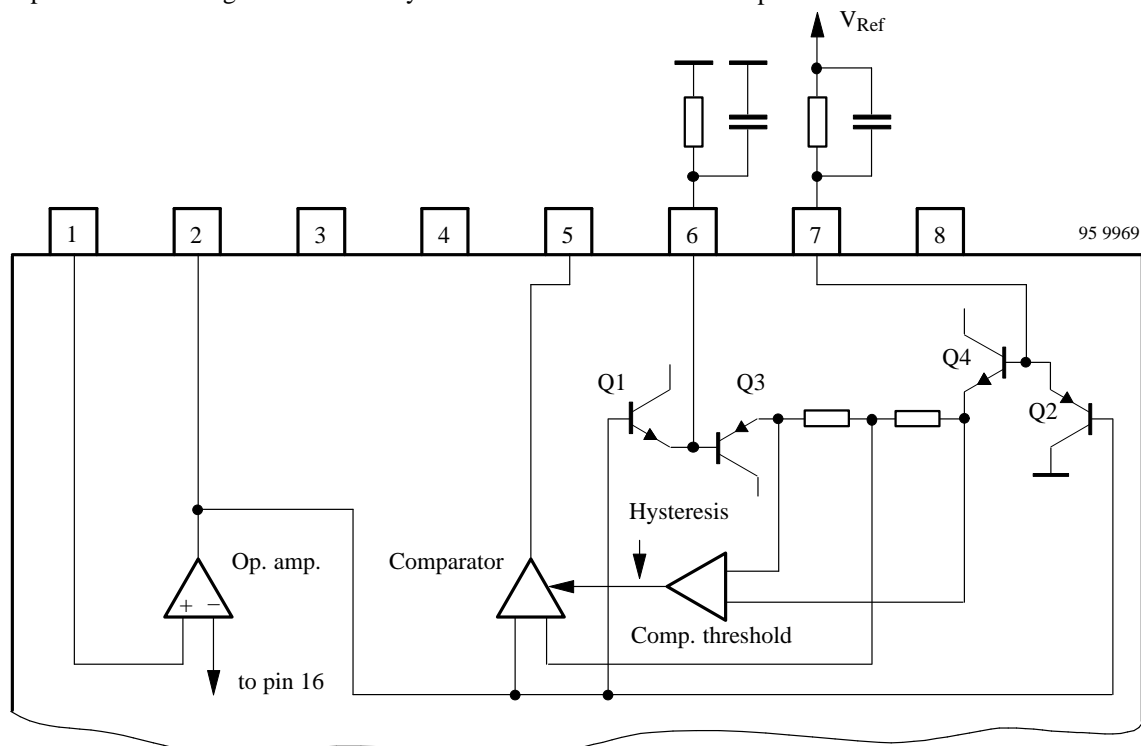

Figure 3. Principle function of the clamping comparator

Internal Pin Circuitry

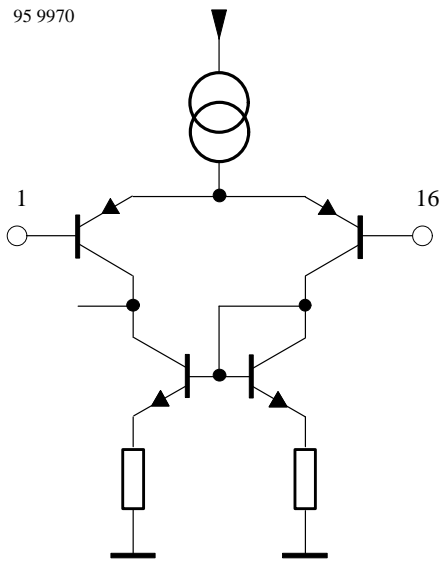

Figure 4. Pin 1 OP_{in+}

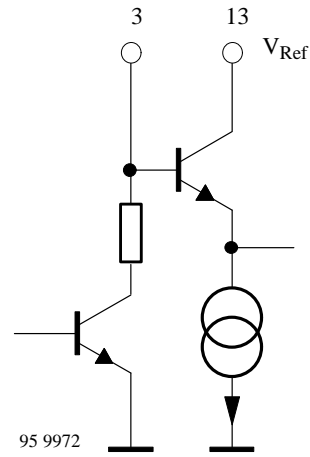

Figure 6. Pin 3 RC_{wake}



Figure 7. Pin 4 GND2

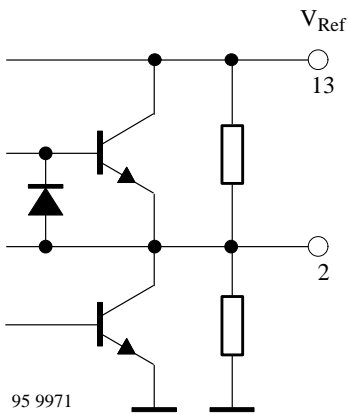

Figure 5. Pin 2 OP_{out}

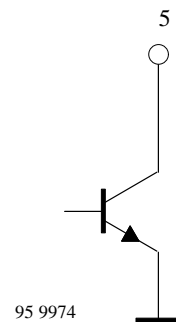

Figure 8. Pin 5 Comp_{out}

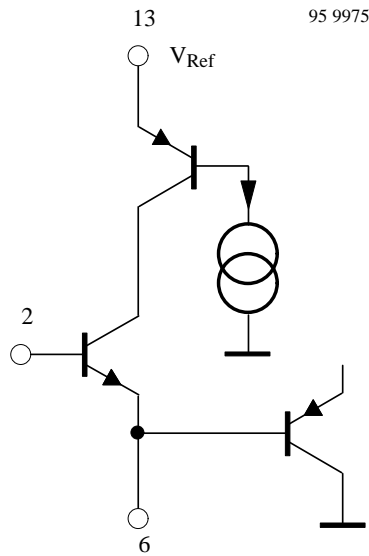

Figure 9. Pin 6 RC-

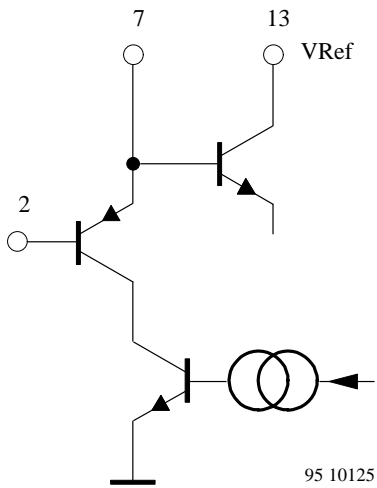

Figure 10. Pin 7 RC+

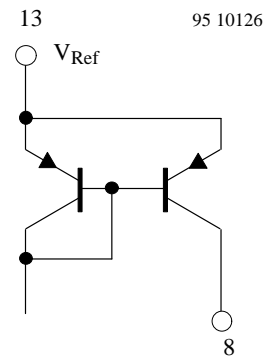

Figure 11. Pin 8 AM_{out}

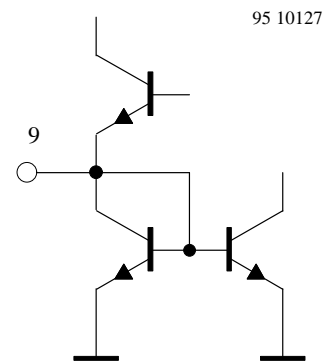

Figure 12. Pin 9 IF_{in}

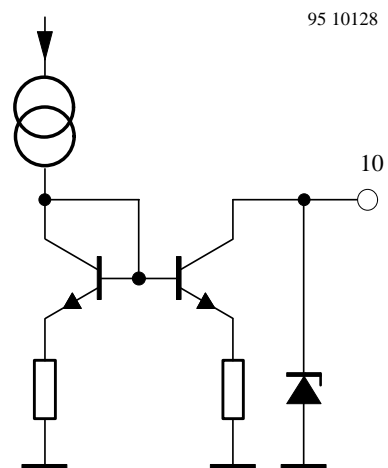

Figure 13. Pin 10 SW_{out}

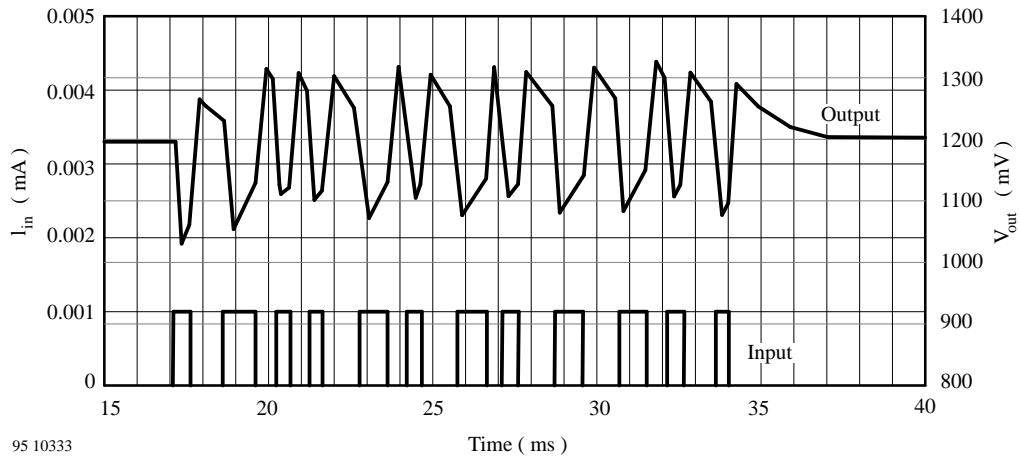

Figure 20. Time domain response of 2 kHz Bessel low pass data filter

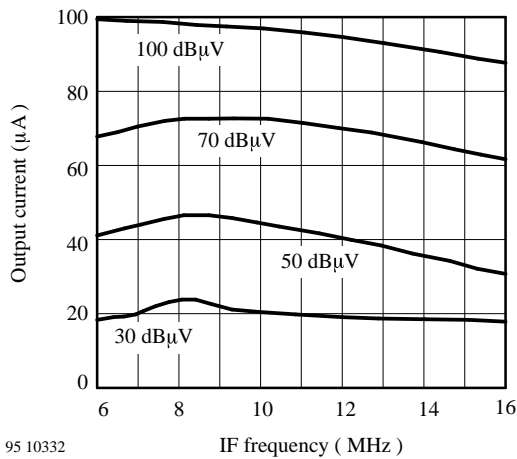

Figure 21. IF-frequency response

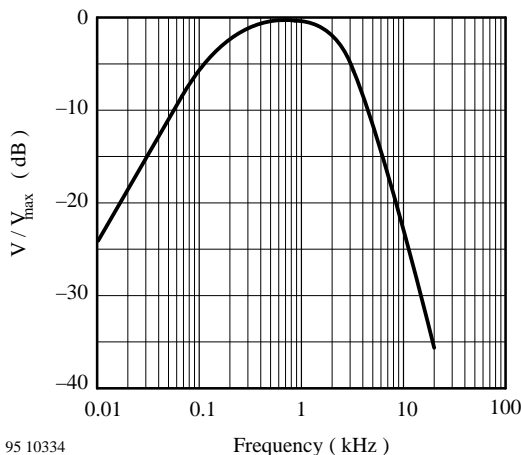

Figure 22. Frequency response of 2 kHz Bessel low pass data filter

Data Recovering Filter

The test circuit in figures 23 and 26 includes an example of a data recovering filter realized with the components R_1, R_2, C_1, C_2, C_3 . It is of a second order Bessel type with low pass characteristic, a 3 dB cut-off frequency of 2 kHz and an additional high pass characteristic for suppressing dc and low frequency ac components. Simulation of time domain and frequency response is drawn in figures 20 and 22. This filter gives a typical application of a 1 kBaud Manchester code amplitude modulated transmission.

The capacitor C_2 is responsible for the high pass cut-off frequency. For a correct pulse response this high pass cut-off frequency should be as low as possible. Figure 20 shows the transient response and the influence of the dc component. The first pulses might be wrong if the high pass cut-off frequency is too low. For this reason some burst bits must be transmitted before the real data transmission starts. On the other hand, if the cut-off frequency is too high, you might get in trouble with roof shaping of the rectangle pulses at the operational amplifier output.

The low pass cut-off frequency and the maximum transimpedance V_{out}/I_{in} are distinguished by the further external elements. Careful design of the data filter gives optimized transmission range. For designing other filter parameters look for filter design handbooks or programs or request TEMIC TELEFUNKEN microelectronic GmbH for support. Some proposals can be found in the application notes ANT012, ANT013 and ANT015.

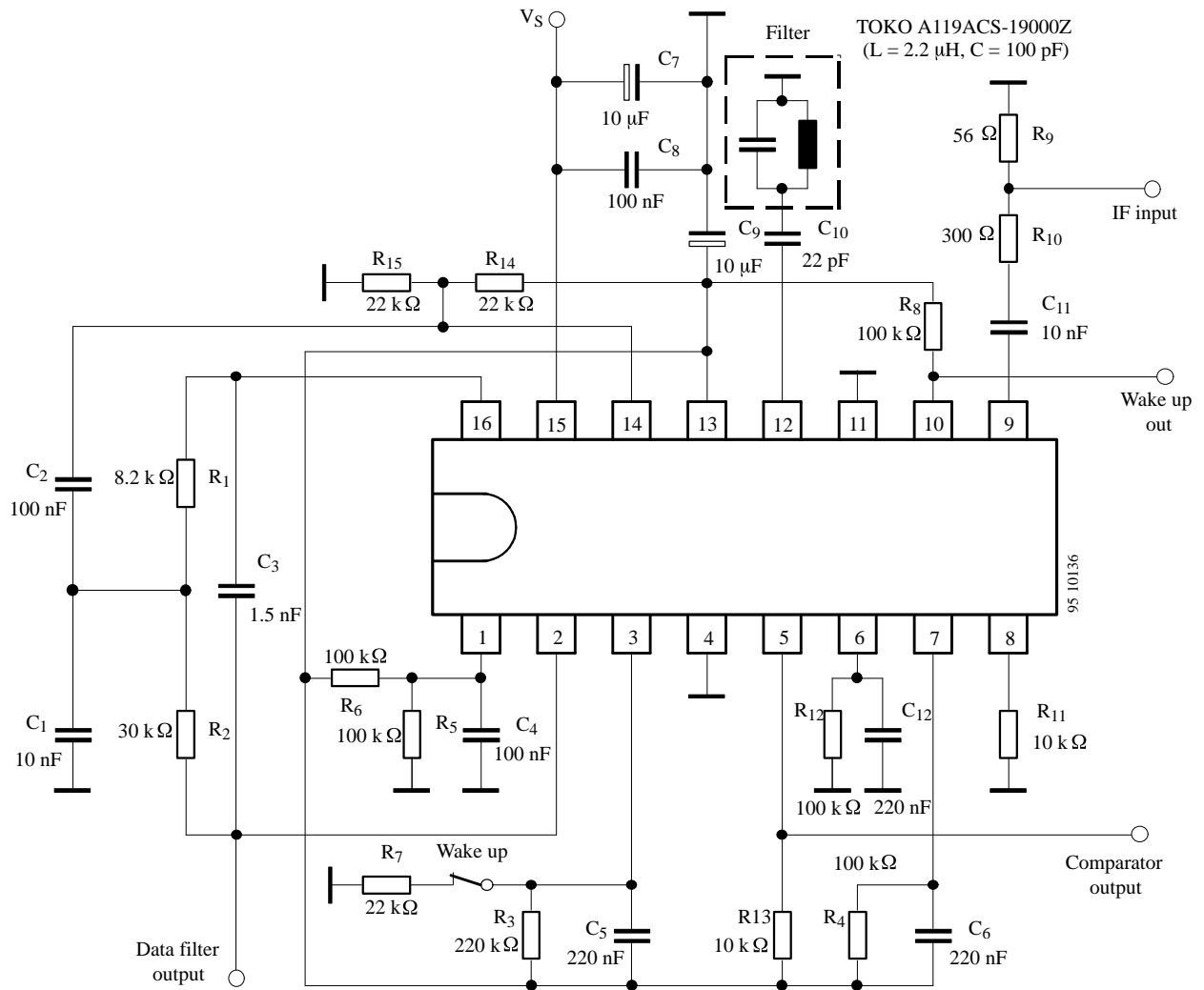

Figure 26. FM test circuit with 2 kHz Bessel low pass data filter

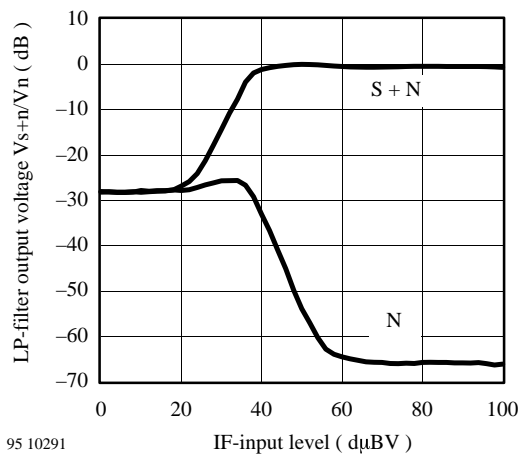

Figure 27. Signal to noise ratio FM; deviation 22.5 kHz

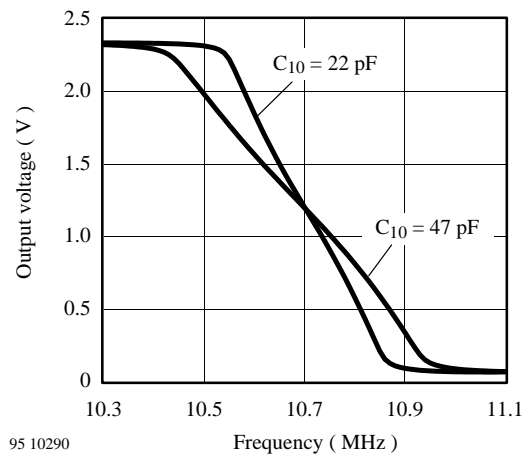
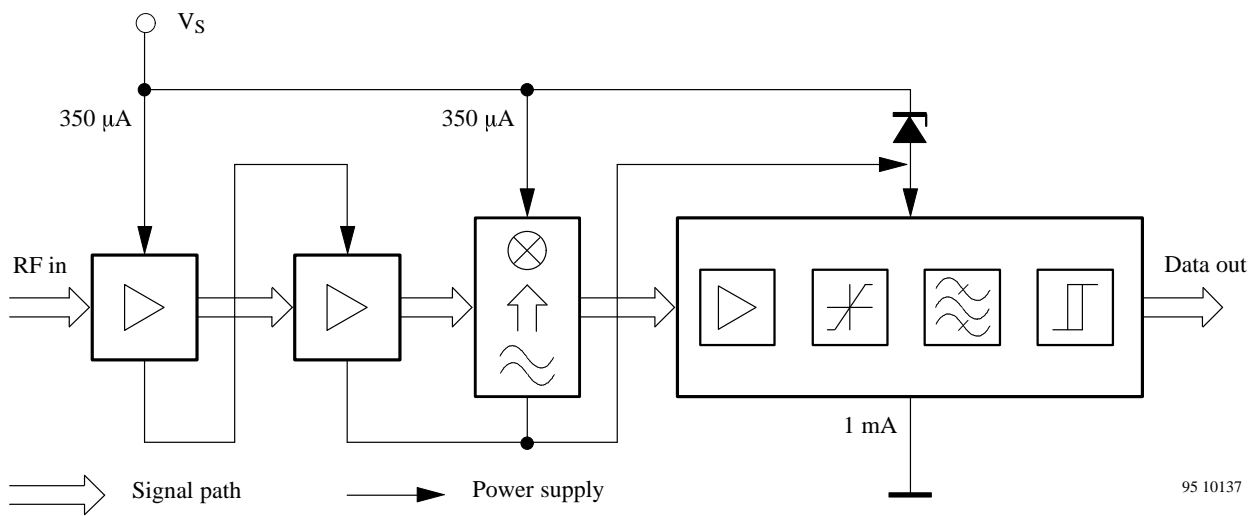

Figure 28. FM-discriminator characteristic



95 10137

Figure 29. Principle diagram UHF remote control receiver

Ordering Information

Extended Type Number	Package	Remarks
U4311B-C	DIP16	
U4311B-CFL	SO16L	

Dimensions in mm

Package: DIP16

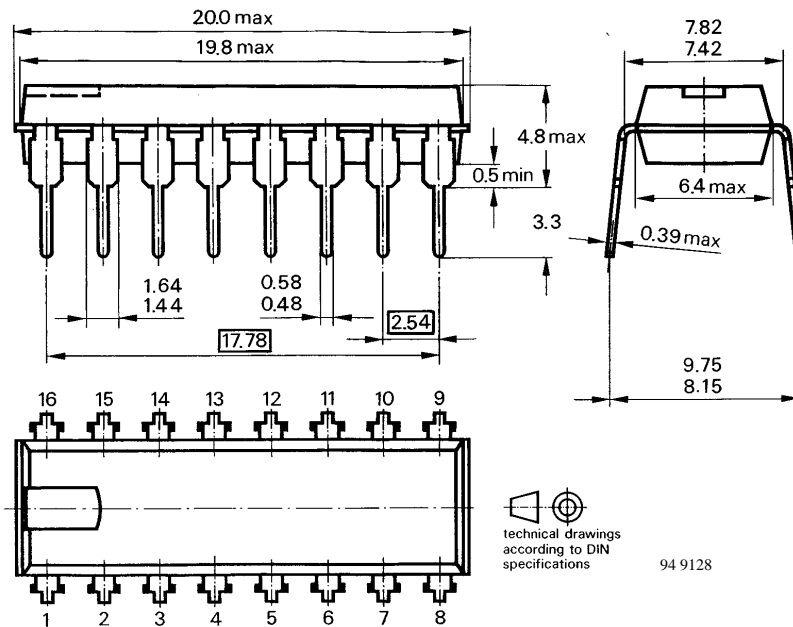

Package: SO16L

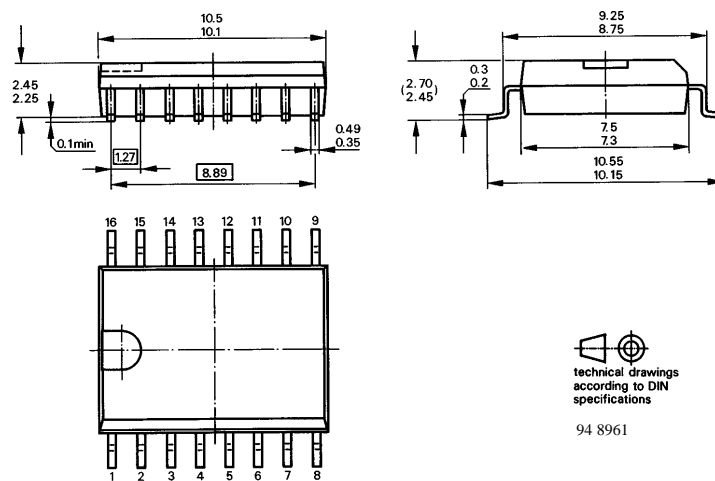

Ozone Depleting Substances Policy Statement

It is the policy of **TEMIC TELEFUNKEN microelectronic GmbH** to

1. Meet all present and future national and international statutory requirements.
2. Regularly and continuously improve the performance of our products, processes, distribution and operating systems with respect to their impact on the health and safety of our employees and the public, as well as their impact on the environment.

It is particular concern to control or eliminate releases of those substances into the atmosphere which are known as ozone depleting substances (ODSs).

The Montreal Protocol (1987) and its London Amendments (1990) intend to severely restrict the use of ODSs and forbid their use within the next ten years. Various national and international initiatives are pressing for an earlier ban on these substances.

TEMIC TELEFUNKEN microelectronic GmbH semiconductor division has been able to use its policy of continuous improvements to eliminate the use of ODSs listed in the following documents.

1. Annex A, B and list of transitional substances of the Montreal Protocol and the London Amendments respectively
2. Class I and II ozone depleting substances in the Clean Air Act Amendments of 1990 by the Environmental Protection Agency (EPA) in the USA
3. Council Decision 88/540/EEC and 91/690/EEC Annex A, B and C (transitional substances) respectively.

TEMIC can certify that our semiconductors are not manufactured with ozone depleting substances and do not contain such substances.

We reserve the right to make changes to improve technical design and may do so without further notice.

Parameters can vary in different applications. All operating parameters must be validated for each customer application by the customer. Should the buyer use TEMIC products for any unintended or unauthorized application, the buyer shall indemnify TEMIC against all claims, costs, damages, and expenses, arising out of, directly or indirectly, any claim of personal damage, injury or death associated with such unintended or unauthorized use.

TEMIC TELEFUNKEN microelectronic GmbH, P.O.B. 3535, D-74025 Heilbronn, Germany
Telephone: 49 (0)7131 67 2831, Fax number: 49 (0)7131 67 2423