



TN1215-600B

STANDARD SCR

FEATURES

- $I_{T(RMS)} = 12\text{ A}$
- $V_{DRM} / V_{RRM} = 600\text{ V}$
- $I_{GT} < 15\text{ mA}$
- $I_{TSM} = 110\text{ A}$

DESCRIPTION

The TN1215-600B SCR uses a high performance TOPGLASS PNP technology.

This part is intended for general purpose applications using surface mount technology and requiring high surge capability (power tools, crowbar protection, voltage regulation, etc...).

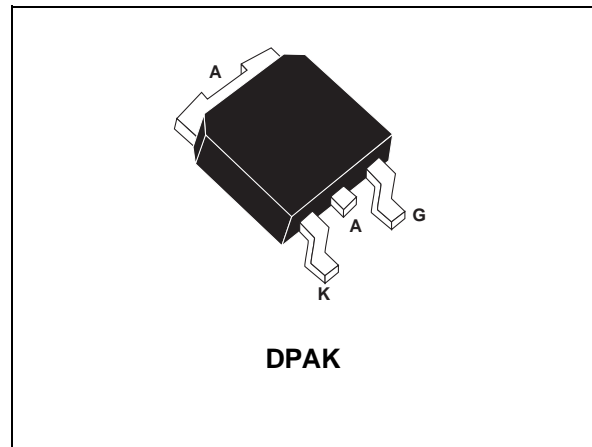

ABSOLUTE MAXIMUM RATINGS

Symbol	Parameter		Value	Unit
V_{DRM} V_{RRM}	Repetitive peak off-state voltage	$T_j = 125^\circ\text{C}$	600	V
$I_{T(RMS)}$	RMS on-state current (180° conduction angle)	$T_c = 105^\circ\text{C}$	12	A
$I_{T(AV)}$	Average on-state current (180° conduction angle)	$T_c = 105^\circ\text{C}$	8	A
I_{TSM}	Non repetitive surge peak on-state current (T_j initial = 25°C)	$t_p = 8.3\text{ ms}$	115	A
		$t_p = 10\text{ ms}$	110	
I^2t	I^2t Value for fusing	$t_p = 10\text{ms}$	60	A^2s
di/dt	Critical rate of rise of on-state current $I_G = 20\text{ mA}$ $di_G/dt = 1\text{ A}/\mu\text{s}$.		50	$\text{A}/\mu\text{s}$
T_{stg} T_j	Storage junction temperature range Operating junction temperature range		- 40 to + 150 - 40 to + 125	$^\circ\text{C}$
T	Maximum temperature for soldering during 10s		260	$^\circ\text{C}$

TN1215-600B

THERMAL RESISTANCES

Symbol	Parameter	Value	Unit
Rth(j-a)	Junction to ambient (S=0.5cm ²)	70	°C/W
Rth(j-c)	Junction to case for D.C	1.5	°C/W

GATE CHARACTERISTICS

$P_{G(AV)} = 1W$ $P_{GM} = 10W$ ($t_p = 20\mu s$) $I_{GM} = 4A$ ($t_p = 20\mu s$) $V_{RGM} = 5V$

ELECTRICAL CHARACTERISTICS

Symbol	Test Conditions		Type	Value	Unit
I _{GT}	V _D = 12V (DC) R _L = 33Ω	T _j = 25°C	MIN	2	mA
			MAX	15	
V _{GT}	V _D = 12V (DC) R _L = 33Ω	T _j = 25°C	MAX	1.5	V
V _{GD}	V _D = V _{DRM} R _L = 3.3kΩ	T _j = 125°C	MIN	0.2	V
I _H	I _T = 100mA Gate open	T _j = 25°C	MAX	40	mA
V _{TM}	I _{TM} = 24A t _p = 380μs	T _j = 25°C	MAX	1.6	V
I _{DRM}	V _D = V _{DRM}	T _j = 25°C	MAX	10	μA
I _{RRM}	V _R = V _{RRM}	T _j = 125°C	MAX	2	mA
dV/dt	Linear slope up to V _D = 67%V _{DRM} Gate open	T _j = 125°C	MIN	200	V/μs

ORDERING INFORMATION

TN	12	15	-	600	B	(-TR)
STANDARD SCR	CURRENT	SENSITIVITY		V _{DRM} / V _{RRM}	PACKAGES : B: DPAK	Tape & Reel

Fig. 1: Maximum average power dissipation versus average on-state current .

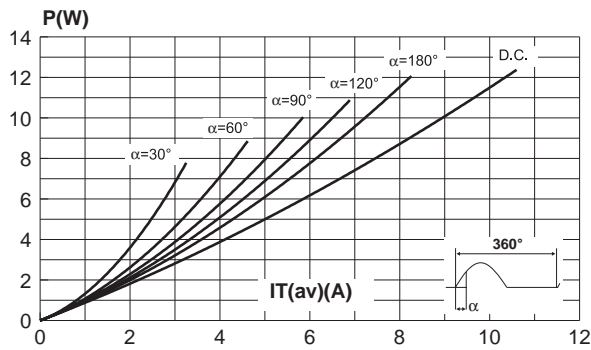

Fig. 2 : Correlation between maximum average power dissipation and maximum allowable temperatures (T_{amb} and T_{case}) for different thermal resistances.

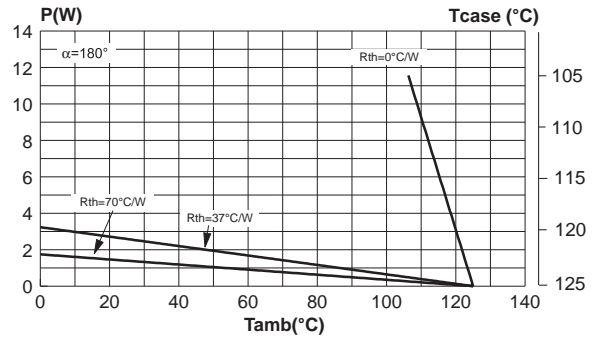

Fig. 3: Average and D.C. on-state current versus case temperature.

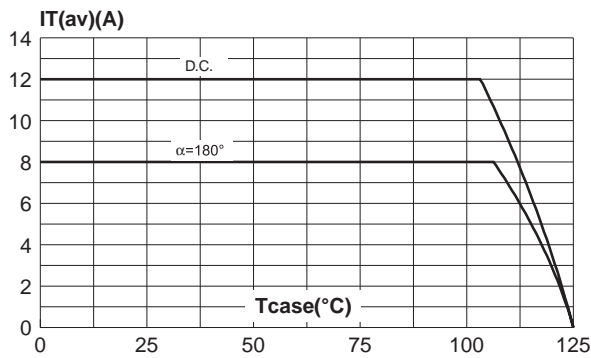

Fig. 4: Average and D.C. on-state current versus ambient temperature (Printed circuit board FR4, SCu=0.5cm2).

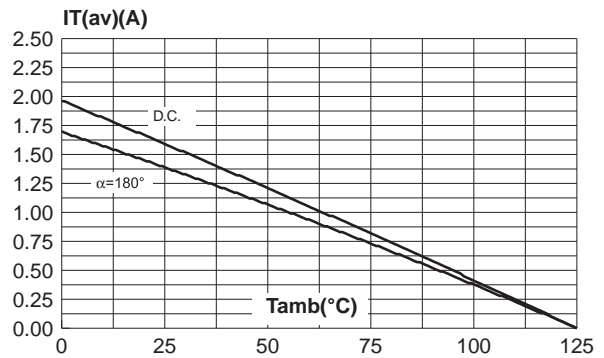

Fig. 5: Relative variation of thermal impedance junction to ambient versus pulse duration (recommended pad layout).

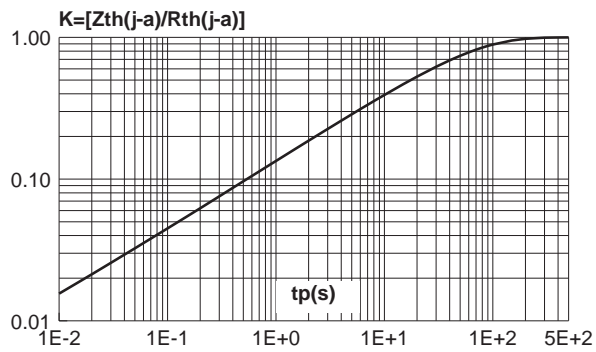

Fig. 6: Relative variation of gate trigger current and holding current versus junction temperature

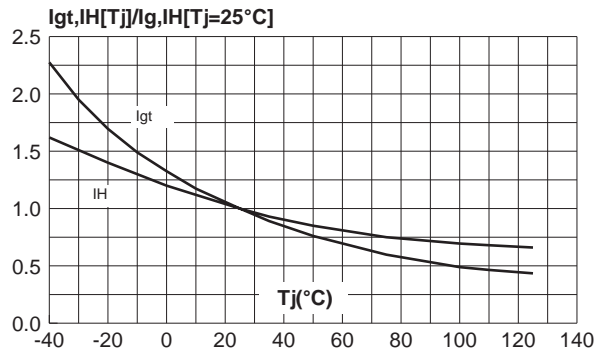

Fig 7: Non repetitive surge peak on-state current versus number of cycles.

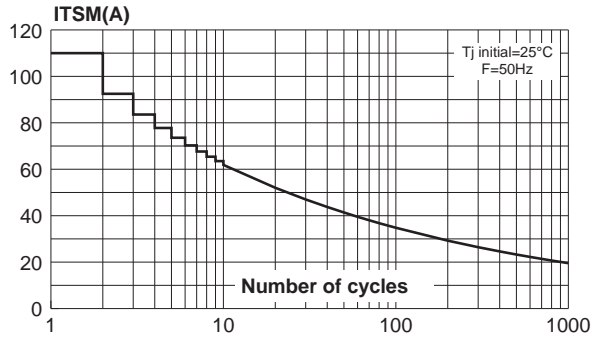

Fig 8: Non repetitive surge peak on-state current for a sinusoidal pulse with width $t_p < 10\text{ms}$, and corresponding value of I_2t .

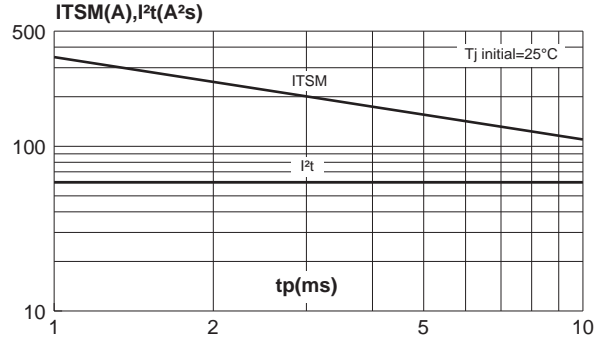

Fig 9: On-state characteristics (maximum values).

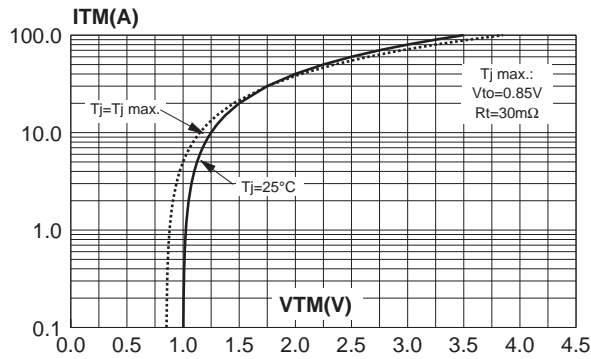
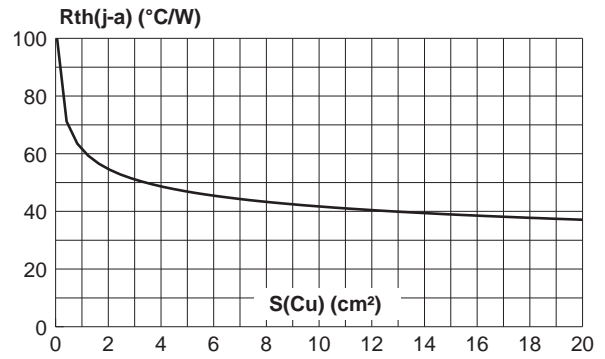
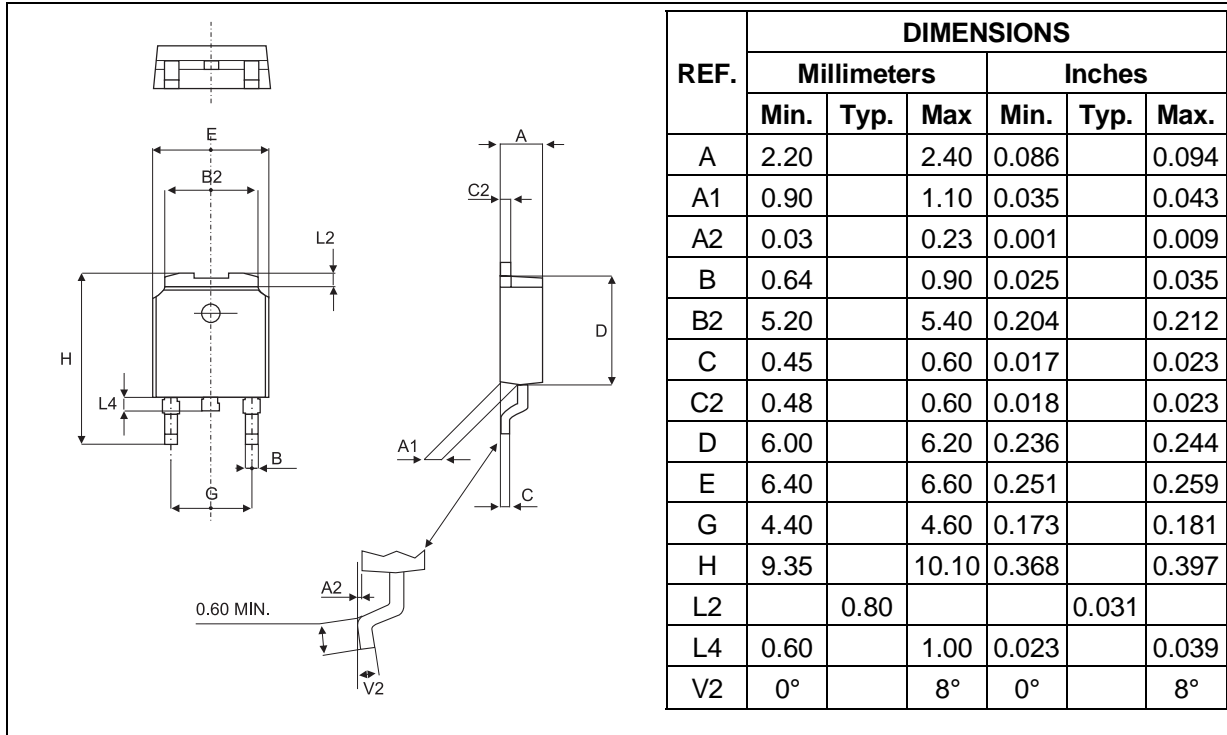

Fig 10: Thermal resistance junction to ambient versus copper surface under tab (Epoxy printed circuit board FR4, copper thickness: 35μm).



PACKAGE MECHANICAL DATA
DPAK



FOOT PRINT DIMENSIONS (in millimeters)

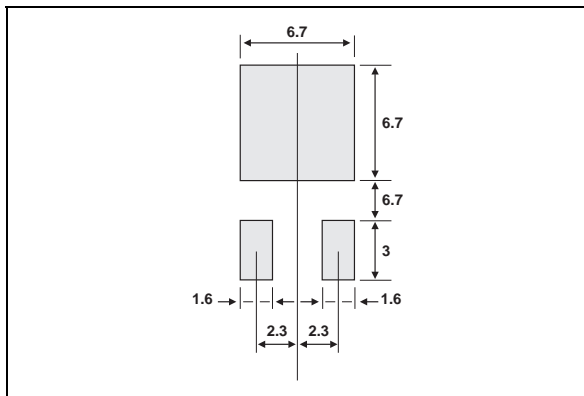

WEIGHT : 0.30g

MARKING

TYPE	MARKING
TN1215-600B	TN 1215 6

Information furnished is believed to be accurate and reliable. However, STMicroelectronics assumes no responsibility for the consequences of use of such information nor for any infringement of patents or other rights of third parties which may result from its use. No license is granted by implication or otherwise under any patent or patent rights of STMicroelectronics. Specifications mentioned in this publication are subject to change without notice. This publication supersedes and replaces all information previously supplied. STMicroelectronics products are not authorized for use as critical components in life support devices or systems without express written approval of STMicroelectronics.

The ST logo is a registered trademark of STMicroelectronics

© 1998 STMicroelectronics - Printed in Italy - All rights reserved.

STMicroelectronics GROUP OF COMPANIES

Australia - Brazil - Canada - China - France - Germany - Italy - Japan - Korea - Malaysia - Malta - Mexico - Morocco - The Netherlands - Singapore - Spain - Sweden - Switzerland - Taiwan - Thailand - United Kingdom - U.S.A.

<http://www.st.com>

