



TSM102/A

DUAL OPERATIONAL AMPLIFIER - DUAL COMPARATOR AND ADJUSTABLE VOLTAGE REFERENCE

OPERATIONAL AMPLIFIERS

- LOW SUPPLY CURRENT : 200 μ A/amp.
- MEDIUM SPEED : 2.1MHz
- LOW LEVEL OUTPUT VOLTAGE CLOSE TO V_{cc}^- : 0.1V typ.
- INPUT COMMON MODE VOLTAGE RANGE INCLUDES GROUND

COMPARATORS

- LOW SUPPLY CURRENT : 200 μ A/amp. ($V_{cc} = 5V$)
- INPUT COMMON MODE VOLTAGE RANGE INCLUDES GROUND
- LOW OUTPUT SATURATION VOLTAGE : 250mV ($I_o = 4mA$)

REFERENCE

- ADJUSTABLE OUTPUT VOLTAGE : V_{ref} to 32V
- SINK CURRENT CAPABILITY : 1 to 100mA
- 1% and 0.4% VOLTAGE PRECISION
- LATCH-UP IMMUNITY

DESCRIPTION

The TSM102 is a monolithic IC that includes two op-amps, two comparators and a precision voltage reference. This device is offering space and cost saving in many applications like power supply management or data acquisition systems.

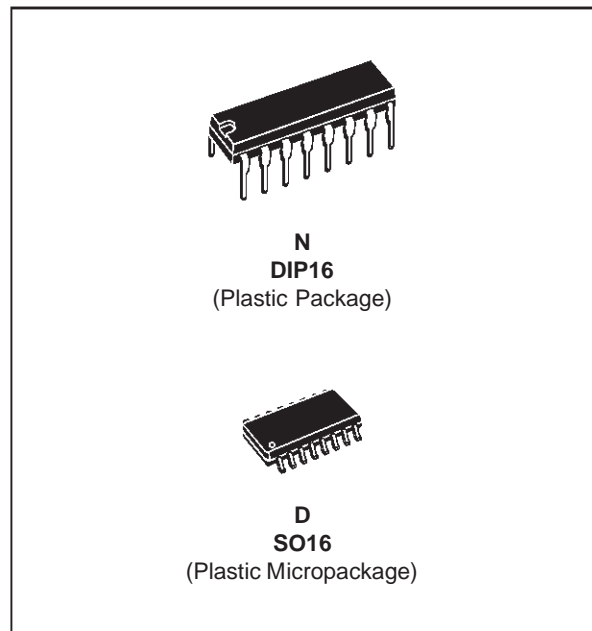

ORDER CODES

Part number	Temperature Range	Package	
		N	D
TSM102I	-40°C, +85°C	•	•
TSM102AI	-40°C, +85°C	•	•

PIN CONNECTIONS

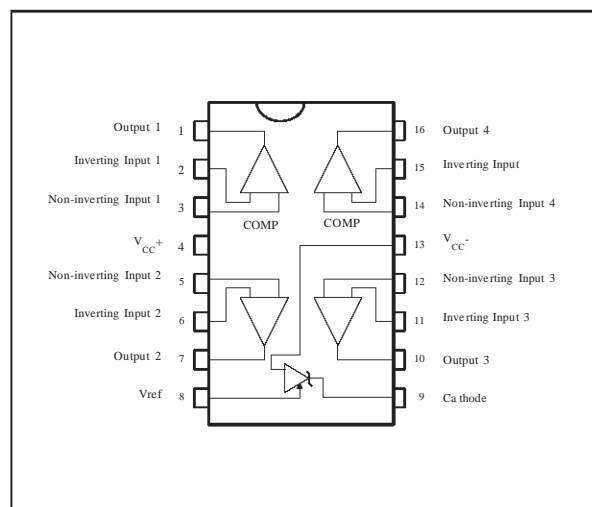

ABSOLUTE MAXIMUM RATINGS

Symbol	Parameter	Value	Unit
V _{CC}	Supply Voltage	36	V
V _{id}	Differential Input Voltage	36	V
V _i	Input Voltage	-0.3 to +36	V
T _{oper}	Operating Free-air Temperature Range	-40 to +125	°C
T _j	Maximum Junction Temperature	150	°C
	Thermal Resistance Junction to Ambient (SO package)	150	°C/W

ELECTRICAL CHARACTERISTICS

V_{CC}⁺ = 5V, V_{CC}⁻ = 0V, T_{amb} = 25°C (unless otherwise specified)

Symbol	Parameter	Min	Typ	Max	Unit
I _{CC}	Total Supply Current T _{min.} < T _{amb} < T _{max.}		0.8	1.5 2	mA

OPERATIONAL AMPLIFIERS

V_{CC}⁺ = 5V, V_{CC} = GND, R1 connected to V_{CC}/2, T_{amb} = 25°C (unless otherwise specified)

Symbol	Parameter	Min.	Typ.	Max.	Unit
V _{io}	Input Offset Voltage T _{min.} ≤ T _{amb} ≤ T _{max.}		1	4.5 6.5	mV
DV _{io}	Input Offset Voltage Drift		10		μV/°C
I _{ib}	Input Bias Current T _{min.} ≤ T _{amb} ≤ T _{max.}		20	100 200	nA
I _{io}	Input Offset Current T _{min.} ≤ T _{amb} ≤ T _{max.}		5	20 40	nA
A _{vd}	Large Signal Voltage Gain R1 = 10k, V _{CC} ⁺ = 30V, V _o = 5V to 25V T _{min.} ≤ T _{amb} ≤ T _{max.}	50 25	100		V/mV
SVR	Supply Voltage Rejection Ratio V _{CC} = 5V to 30V	80	100		dB
V _{icm}	Input Common Mode Voltage Range T _{min.} ≤ T _{amb} ≤ T _{max.}	(V _{CC} ⁻) to (V _{CC} ⁺) -1.8 (V _{CC}) to (V _{CC} ⁺) -2.2			V
CMR	Common Mode Rejection Ratio V _{CC} ⁺ = 30V, V _{icm} = 0V to (V _{CC} ⁺) -1.8V	70	90		dB
I _{sc}	Output Short Circuit Current V _{id} = ±1V, V _o = 2.5V Source Sink	3 3	6 6		mA
V _{OH}	High Level Output Voltage V _{CC} ⁺ = 30V R _L = 10kΩ T _{min.} ≤ T _{amb} ≤ T _{max.}	27 26	28		V
V _{OL}	Low Level Output Voltage R _L = 10kΩ T _{min.} ≤ T _{amb} ≤ T _{max.}		100	150 210	mV
SR	Slew Rate V _{CC} = ±15V V _i = ±10V, R _L = 10kΩ, C _L = 100pF	1.6	2		V/μs
GBP	Gain Bandwidth Product R _L = 10kΩ, C _L = 100pF, f = 100kHz	1.4	2.1		MHz
∅ _m	Phase Margin R _L = 10kΩ, C _L = 100pF		45		Degrees
THD	Total Harmonic Distortion		0.05		%
e _n	Equivalent Input Noise Voltage f = 1kHz		29		nV √Hz
C _s	Channel Separation		120		dB

COMPARATORS

$V_{CC}^+ = +5V$, $V_{CC} = \text{Ground}$, $T_{amb} = 25^{\circ}C$ (unless otherwise specified)

Symbol	Parameter	Min.	Typ.	Max.	Unit
V_{io}	Input Offset Voltage $T_{min.} \leq T_{amb} \leq T_{max.}$			5 9	mV
I_{io}	Input Offset Current $T_{min.} \leq T_{amb} \leq T_{max.}$			50 150	nA
I_{ib}	Input Bias Current $T_{min.} \leq T_{amb} \leq T_{max.}$			250 400	nA
I_{OH}	High Level Output Current $V_{id} = 1V$, $V_{CC} = V_o = 30V$ $T_{min.} \leq T_{amb} \leq T_{max.}$		0.1	1	nA μA
V_{OL}	Low Level Output Voltage $V_{id} = -1V$, $I_{sink} = 4mA$ $T_{min.} \leq T_{amb} \leq T_{max.}$		250	400 700	mV
A_{vd}	Large Signal Voltage Gain $R1 = 15k$, $V_{CC} = 15V$, $V_o = 1$ to $11V$		200		V/mV
I_{sink}	Output Sink Current $V_{id} = -1V$, $V_o = 1.5V$	6	16		mA
V_{icm}	Input Common Mode Voltage Range $T_{min.} \leq T_{amb} \leq T_{max.}$	0 0		$V_{CC}^+ - 1.5$ $V_{CC}^+ - 2$	V
V_{id}	Differential Input Voltage			V_{CC}^+	V
t_{re}	Response Time - (note 1) $R1 = 5.1k$ to V_{CC}^+ , $V_{ref} = 1.4V$		1.3		μs
t_{rel}	Large Signal Response Time $V_{ref} = 1.4V$, $V_i = \text{TTL}$, $R1 = 5.1k$ to V_{CC}^+		300		ns

Note 1 : The response time specified is for 100mV input step with 5mV overdrive.
For larger overdrive signals, 300ns can be obtained.

TSM102

VOLTAGE REFERENCE

Symbol	Parameter	Value	Unit
V_{KA}	Cathode to Anode Voltage	V_{ref} to 36	V
I_K	Cathode Current	1 to 100	mA

ELECTRICAL CHARACTERISTICS

$T_{amb} = 25^{\circ}\text{C}$ (unless otherwise specified)

Symbol	Parameter	Min.	Typ.	Max.	Unit
V_{ref}	Reference Input Voltage - (figure 1) - $T_{amb} = 25^{\circ}\text{C}$ TSM102, $V_{KA} = V_{ref}$, $I_K = 10\text{mA}$ TSM102A, $V_{KA} = V_{ref}$, $I_K = 10\text{mA}$	2.475 2.490	2.500 2.500	2.525 2.510	V
ΔV_{ref}	Reference Input Voltage Deviation Over Temperature Range - (figure 1, note 1) $V_{KA} = V_{ref}$, $I_K = 10\text{mA}$, $T_{min.} \leq T_{amb} \leq T_{max.}$		7	30	mV
$\frac{\Delta V_{ref}}{\Delta T}$	Temperature Coefficient of Reference Input Voltage - (note 2) $V_{KA} = V_{ref}$, $I_K = 10\text{mA}$, $T_{min.} \leq T_{amb} \leq T_{max.}$		± 22	± 100	ppm/ $^{\circ}\text{C}$
$\frac{\Delta V_{ref}}{\Delta V_{KA}}$	Ratio of Change in Reference Input Voltage to Change in Cathode to Anode Voltage - (figure 2) $I_K = 10\text{mA}$, $\Delta V_{KA} = 36$ to 3V		-1.1	-2	mV/V
I_{ref}	Reference Input Current - (figure 2) $I_K = 10\text{mA}$, $R_1 = 10\text{k}\Omega$, $R_2 = \infty$ $T_{amb} = 25^{\circ}\text{C}$ $T_{min.} \leq T_{amb} \leq T_{max.}$		1.5	2.5 3	μA
ΔI_{ref}	Reference Input Current Deviation Over Temperature Range - (figure 2) $I_K = 10\text{mA}$, $R_1 = 10\text{k}\Omega$, $R_2 = \infty$ $T_{min.} \leq T_{amb} \leq T_{max.}$		0.5	1	μA
I_{min}	Minimum Cathode Current for Regulation - (figure 1) $V_{KA} = V_{ref}$		0.5	1	mA
I_{off}	Off-State Cathode Current - (figure 3)		180	500	nA

Notes : 1. ΔV_{ref} is defined as the difference between the maximum and minimum values obtained over the full temperature range.

$$\Delta V_{ref} = V_{refmax.} - V_{refmin.}$$

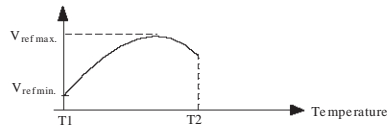

2. The temperature coefficient is defined as the slopes (positive and negative) of the voltage vs temperature limits within which the reference voltage is guaranteed.

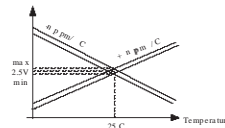

3. The dynamic Impedance is defined as $|Z_{KA}| = \frac{\Delta V_{KA}}{\Delta I_K}$

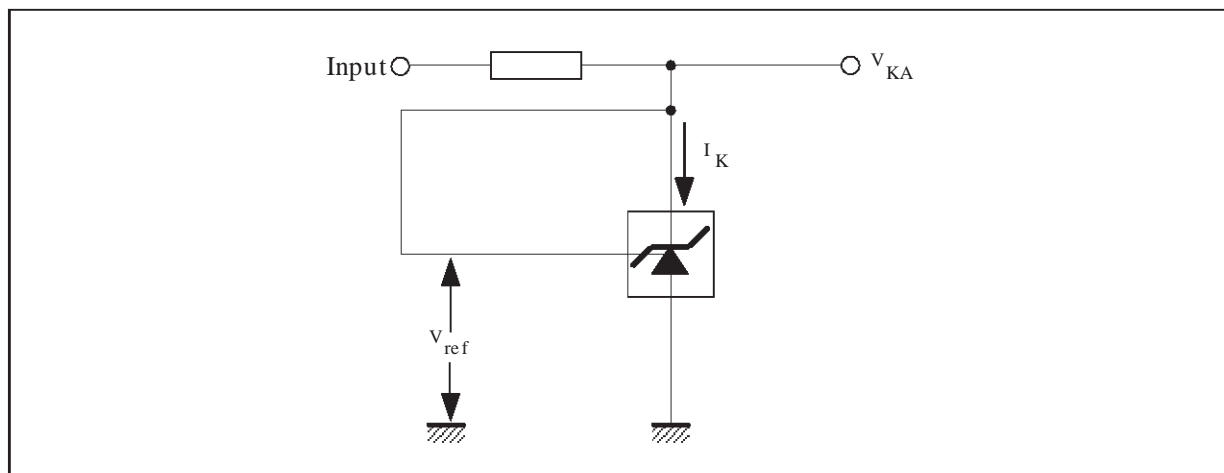
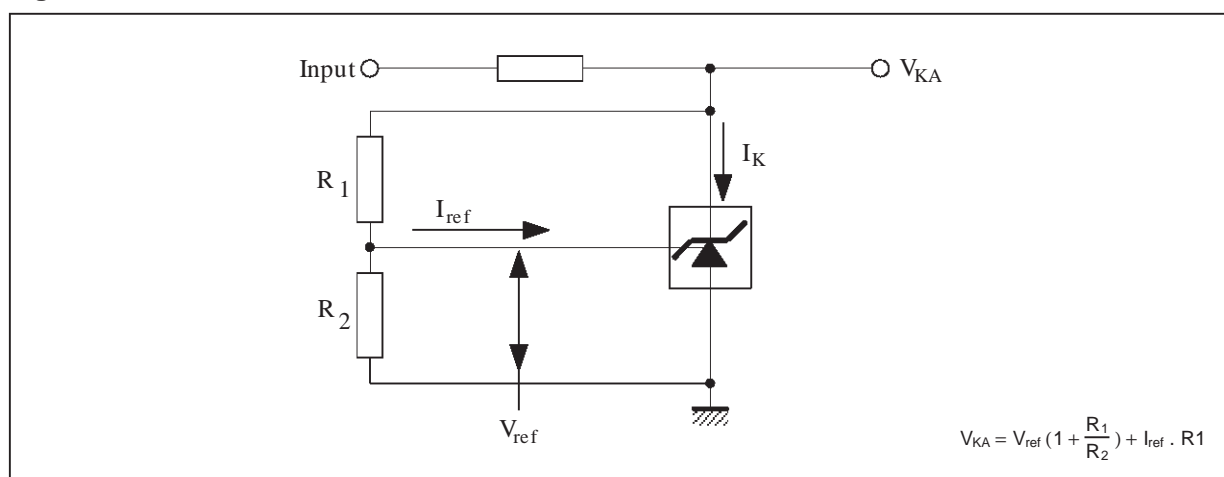
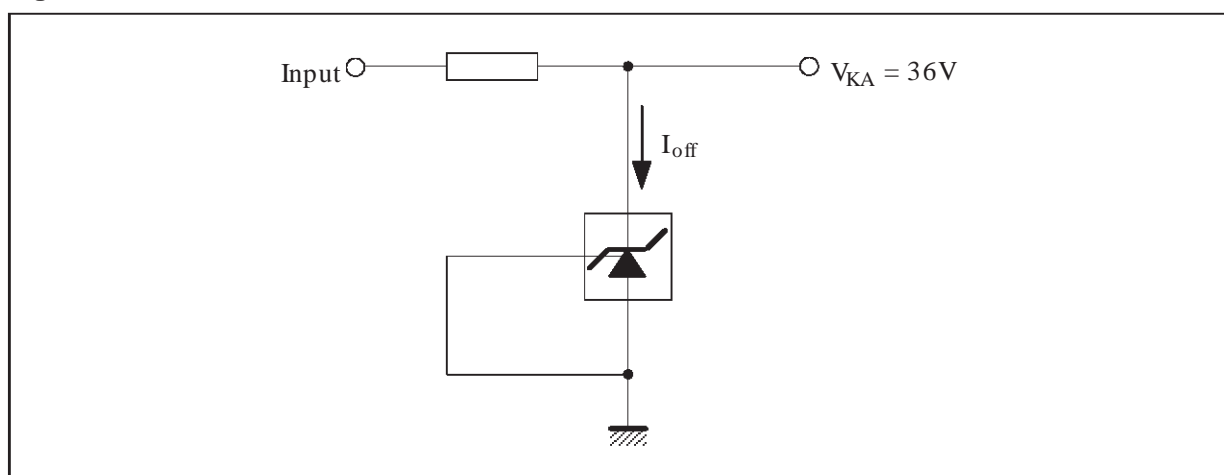
Figure 1 : Test Circuit for $V_{KA} = V_{ref}$ **Figure 2 :** Test Circuit for $V_{KA} > V_{ref}$ **Figure 3 :** Test Circuit for I_{off} 

A Li-Ion BATTERY CHARGER USING TSM102A

by R. LIOU

This application note explains how to use the TSM102 in an SMPS-type battery charger which features :

- Voltage Control
- Current Control
- Low Battery Detection and End Of Charge Detection

1 - TSM102 PRESENTATION

The **TSM102** integrated circuit includes two Operational Amplifiers, two Comparators and one adjustable precision Voltage Reference (2.5V to 36V, 0.4% or 1%).

TSM102 can sustain up to 36V power supply voltage.

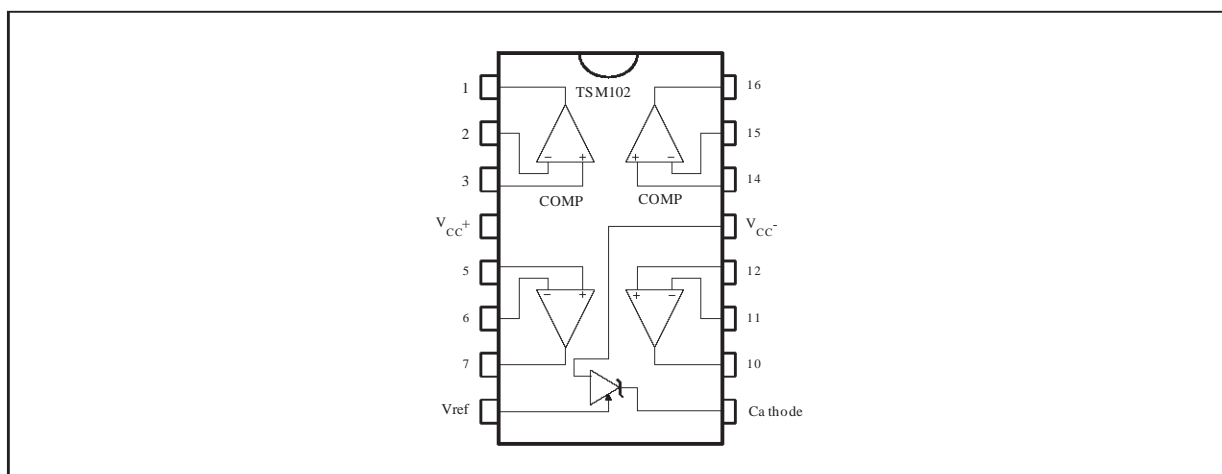
Figure 1 : TSM102 Pinout**2 - APPLICATION CONTEXT AND PRINCIPLE OF OPERATION**

In the battery charging field which requires ever increasing performances in more and more reduced space, the TSM102A provides an attractive solution in terms of PCB area saving, precision and versatility.

Figure 2 shows the secondary side of a battery charger (SMPS type) where TSM102A is used in optimised conditions : the two Operational Amplifiers perform current and voltage control, the two Comparators provide "End of Charge" and "Low Battery" signals and the Voltage Reference ensures precise reference for all measurements.

The TSM102A is supplied by an auxiliary power supply (forward configuration - D7) regulated by a bipolar transistor and a zener diode on its base (Q2 and DZ), and smoothed by the capacitors C3 and

C4. R15 polarizes the base of the transistor and at the same time limits the current through the zener diode during regulation mode of the auxiliary power supply.

The current and voltage regulations are made thanks to the two Operational Amplifiers.

The first amplifier senses the current flow through the sense resistor R_s and compares it with a part of the reference voltage (resistor bridge R7, R8, R9). The second amplifier compares the reference voltage with a part of the charger's output (resistor bridge R1, R2, R3).

When either of these two operational amplifiers tends to lower its output, this linear information is propagated towards the primary side via two ORing diodes (D1, D2) and an optocoupler (D3). The compensation loops of these regulation functions are ensured by the capacitors C1 and C2.

Figure 2 : The Application Schematic - Battery Charger Secondary Side

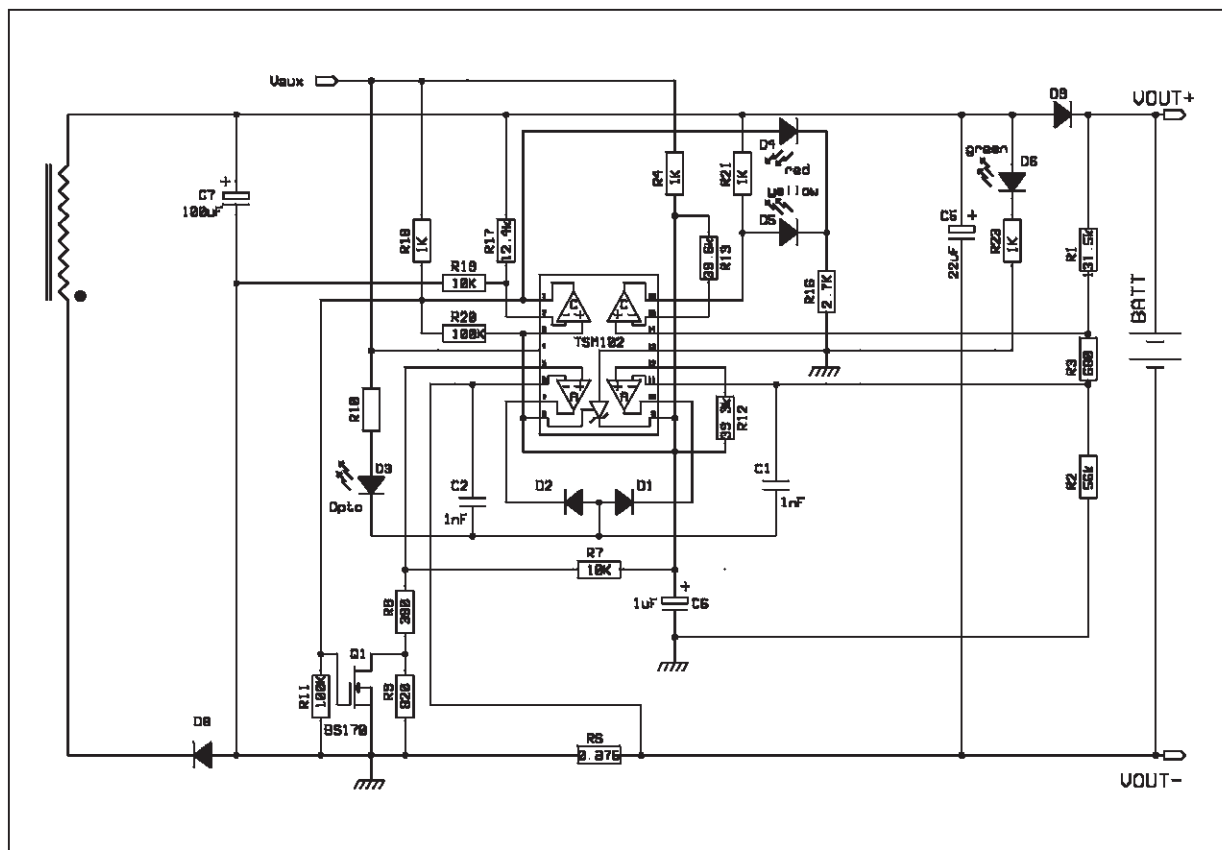

The first comparator ensures the "Low Battery" signal generation thanks to the comparison of a part of the charger's output voltage (resistor bridge R17, R19) and the reference voltage. Proper hysteresis is given thanks to R20. An improvement to the charger's security and to the battery's life time optimization is achieved by lowering the current control measurement thanks to Q1 that shunts the resistor R9 when the battery's voltage is below the "Low Battery" level.

The second comparator ensures the "End of Charge" signal generation thanks to the comparison of a part of the charger's output voltage (resistor bridge R1, R2, R3) and the reference voltage.

When either of these two signals is active, the corresponding LED is polarized for convenient visualization of the battery status.

3 - CALCULATION OF THE ELEMENTS

All the components values have been chosen for a two-Lithium-Ion batteries charge application :

- Current Control : 720mA (Low Battery current control : 250mA)

- Voltage Control : 8.4V (= 2x 4.2V)
- Low Battery : 5.6V (= 2x 2.5V + 0.6V)
- End of Charge : 8.3V (= 2x 4.15V)

Current Control :

The voltage reference is polarized thanks to the R4 resistor (2.5mA), and the cathode of the reference gives a fixed 2.500V voltage.

$$I = U / R = [V_{ref} (R_8 + R_9) / (R_7 + R_8 + R_9)] / R_s$$

$$= [2.5 \times (390 + 820) / (10000 + 390 + 820)] / 0.375$$

$$= 720\text{mA}$$

$$I = 720\text{mA}$$

$$P = \text{power dissipation through the sense resistor} = R_{12}$$

$$= 0.375 \times 0.7202 = 194\text{mW}$$

In case of "Low Battery" conditions, the current control is lowered thanks to the following equation :

$$I = U / R = [V_{ref} R_8 / (R_7 + R_8)] / R_s$$

$$= [2.5 \times 390 / (10000 + 390)] / 0.375$$

$$= 250\text{mA}$$

$$I (\text{LoBatt}) = 250\text{mA}$$

Voltage Control :

$$V_{out} = V_{ref} / [R_2 / (R_1 + R_2 + R_3)]$$

TSM102

$$= 2.5 / [56 / (131.5 + 56 + 0.68)]$$

$$= 8.400V$$

Vout = 8.400V

Low Battery signal :

If R5 = 0Ω and R6 = open :

$$V_{out}(LoBatt) = V_{ref} / [R_{19} / (R_{17} + R_{19})]$$

$$= 2.5 / [10 / (12.4 + 10)]$$

$$= 5.6V$$

Vout(LoBatt) = 5.6V

End of Charge signal :

$$V_{out}(EOC) = V_{ref} / [(R_2 + R_3) / (R_1 + R_2 + R_3)]$$

$$= 2.5 / [(56 + 0.68) / (131.5 + 56 + 0.68)]$$

$$= 8.300V$$

Vout (EOC)= 8.300V

Notes:

The current control values must be chosen in accordance with the elements of the primary side. The performances of the battery charger in their globality are highly dependent on the adequation of the primary and the secondary elements.

The addition of the diode D9 is necessary to avoid dramatic discharge of the battery cells in case of the charger disconnection from the mains voltage, and therefore, the voltage measurement is to be operated on the cathode side of the diode not to take its voltage drop into account. The total bridge value of R1, R2, R3 must ensure low battery discharge if the charger is disconnected from main, but remains connected to the battery by mistake. The chosen values impose a 44μA discharge current max.

R12 and R13 are the equivalent resistors seen from the opamp and from the comparator.

A hysteresis resistor can be connected to the "End Of Charge" comparator to ensure proper hysteresis to this signal, but this resistor must be chosen carefully not to degrade the output voltage precision. It might be needed to impose unidirectional hysteresis (by inserting a diode on the positive feedback of the comparator).

Figure 3 shows how to use the integrated Voltage Reference to build a precise Power Supply for the

Figure 3 : A precise power supply for the TSM102A and other components

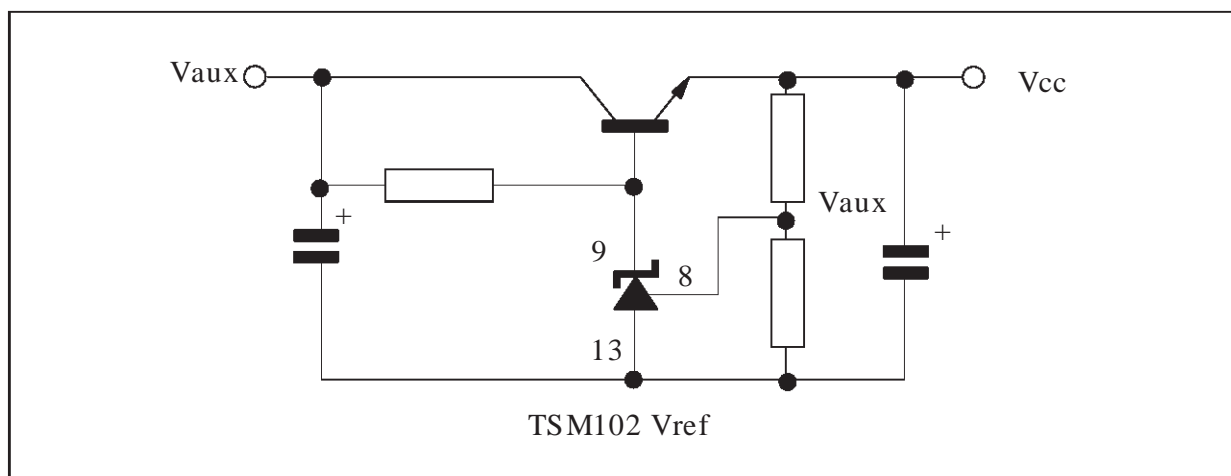

PACKAGE MECHANICAL DATA

16 PINS - PLASTIC PACKAGE

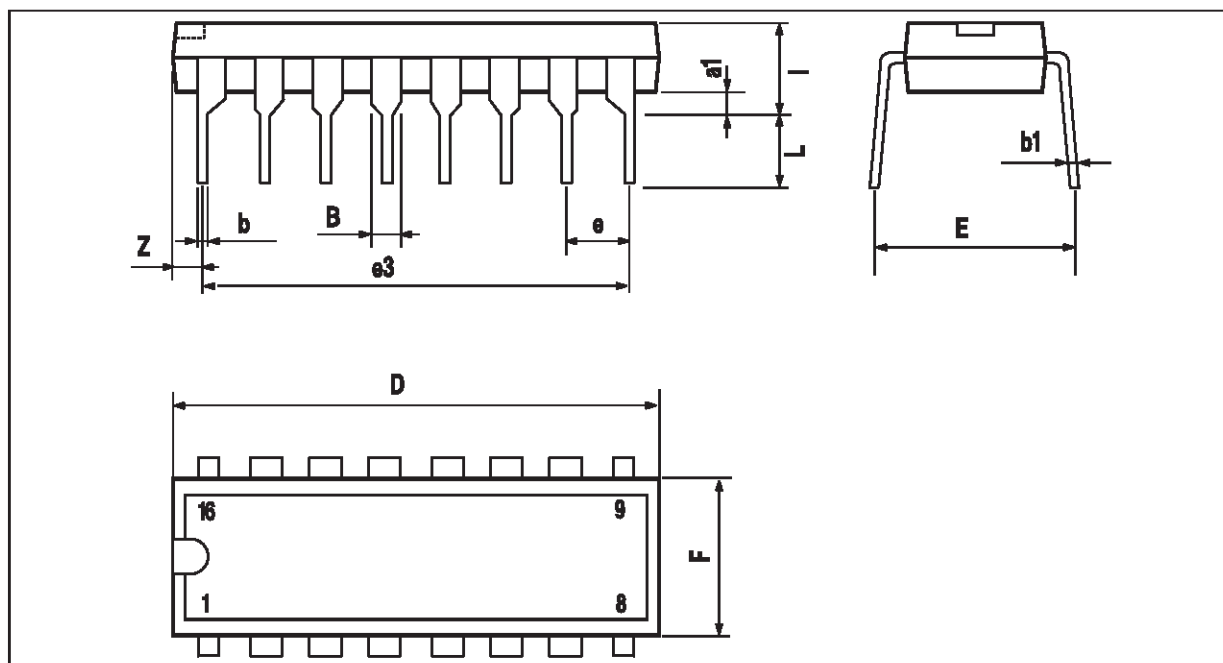

Dim.	Millimeters			Inches		
	Min.	Typ.	Max.	Min.	Typ.	Max.
a1	0.51			0.020		
B	0.77		1.65	0.030		0.065
b		0.5			0.020	
b1		0.25			0.010	
D			20			0.787
E		8.5			0.335	
e		2.54			0.100	
e3		17.78			0.700	
F			7.1			0.280
i			5.1			0.201
L		3.3			0.130	
Z			1.27			0.050

PACKAGE MECHANICAL DATA
 16 PINS - PLASTIC MICROPACKAGE (SO)

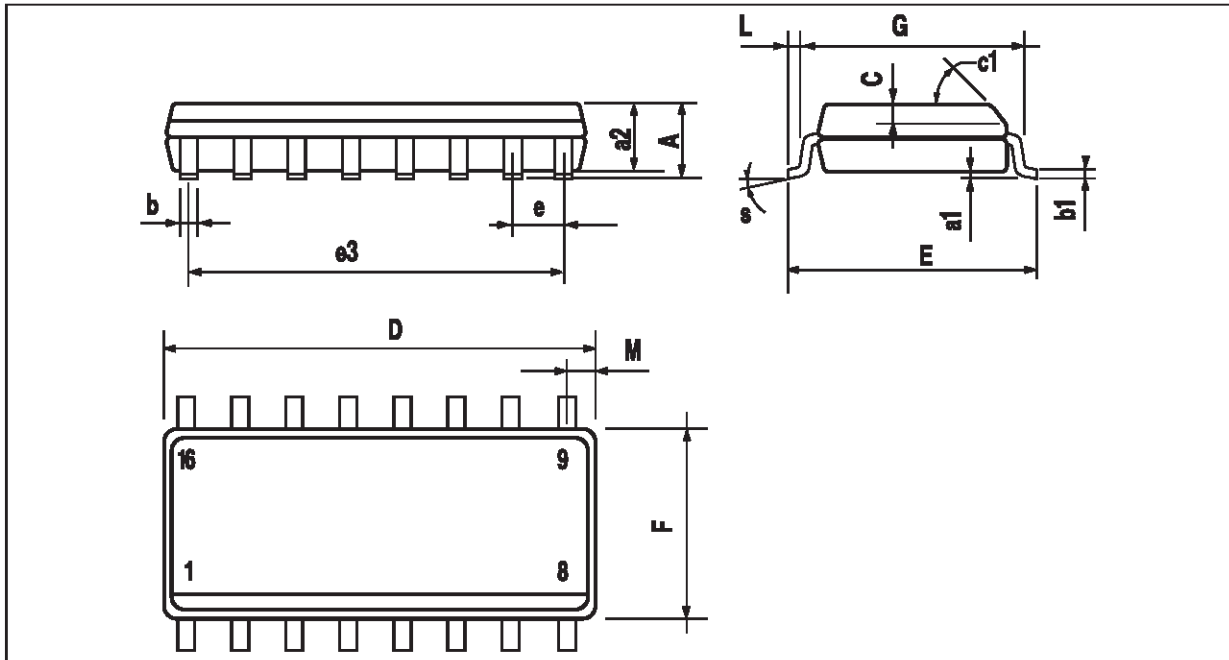

Dim.	Millimeters			Inches		
	Min.	Typ.	Max.	Min.	Typ.	Max.
A			1.75			0.069
a1	0.1		0.2	0.004		0.008
a2			1.6			0.063
b	0.35		0.46	0.014		0.018
b1	0.19		0.25	0.007		0.010
C		0.5			0.020	
c1	45° (typ.)					
D	9.8		10	0.386		0.394
E	5.8		6.2	0.228		0.244
e		1.27			0.050	
e3		8.89			0.350	
F	3.8		4.0	0.150		0.157
G	4.6		5.3	0.181		0.209
L	0.5		1.27	0.020		0.050
M			0.62			0.024
S	8° (max.)					

Information furnished is believed to be accurate and reliable. However, STMicroelectronics assumes no responsibility for the consequences of use of such information nor for any infringement of patents or other rights of third parties which may result from its use. No license is granted by implication or otherwise under any patent or patent rights of STMicroelectronics. Specifications mentioned in this publication are subject to change without notice. This publication supersedes and replaces all information previously supplied. STMicroelectronics products are not authorized for use as critical components in life support devices or systems without express written approval of STMicroelectronics.

© The ST logo is a trademark of STMicroelectronics

© 1998 STMicroelectronics - Printed in Italy - All Rights Reserved

STMicroelectronics GROUP OF COMPANIES
 Australia - Brazil - Canada - China - France - Germany - Italy - Japan - Korea - Malaysia - Malta - Mexico - Morocco
 The Netherlands - Singapore - Spain - Sweden - Switzerland - Taiwan - Thailand - United Kingdom - U.S.A.

© <http://www.st.com>