

DATA SHEET

TEA5757; TEA5759 **Self Tuned Radio (STR)**

Preliminary specification
Supersedes data of July 1994
File under Integrated Circuits, IC01

1996 Jan 09

Self Tuned Radio (STR)**TEA5757; TEA5759****FEATURES**

- The tuning system has an optimized IC partitioning both from application (omitting interferences) and flexibility (removable front panel option) point of view: the tuning synthesizer is on-chip with the radio
- The tuning quality is superior and requires no IF-counter for stop-detection; it is insensitive to ceramic filter tolerances
- In combination with the microcontroller, fast, low-power operation of preset mode, manual-search, auto-search and auto-store are possible
- The local (internal) controller function facilitates reduced and simplified microcontroller software
- The high integration level (radio and tuning synthesizer on one chip) means fewer external components with regard to the communication between the radio and the microcontroller (90% less components compared to the digital tuning application of a radio IC with external PLL tuning function) and a simple and small PCB
- There will be no application considerations for the tuning system, with regards to quality and high integration level, since there will be no external 110 MHz buffers, loop filter or false lock elimination
- The inherent FUZZY LOGIC behaviour of the Self Tuned Radio (STR), which mimics hand tuning, yields a potentially fast yet reliable tuning operation
- The level of the incoming signal at which the radio must lock is software programmable
- Two programmable ports

- High selectivity with distributed IF gain
- Soft mute
- Signal dependent stereo-blend
- High impedance MOSFET input on AM
- Wide supply voltage range of 2.5 to 12 V
- Low current consumption 18 mA at AM and FM (including tuning synthesizer)
- High input sensitivity
- Low output distortion
- Due to the new tuning concept, the tuning is independent of the channel spacing.

GENERAL DESCRIPTION

The TEA5757; TEA5759 is a 44-pin integrated AM/FM stereo radio circuit including a novel tuning concept. The radio part is based on the TEA5712.

The TEA5757 is used in FM-standards in which the local oscillator frequency is above the radio frequency (e.g. european and american standards).

The TEA5759 is the version in which the oscillator frequency is below the radio frequency (e.g. japanese standard).

The new tuning concept combines the advantages of hand tuning with electronic facilities and features. User 'intelligence' is incorporated into the tuning algorithm and an improvement of the analog signal processing is used for the AFC function.

ORDERING INFORMATION

| TYPE NUMBER | PACKAGE | | |
|-------------|---------|---|----------|
| | NAME | DESCRIPTION | VERSION |
| TEA5757H | QFP44 | plastic quad flat package; 44 leads (lead length 1.3 mm); body 10 × 10 × 1.75 mm | SOT307-2 |
| TEA5759H | | | |

Self Tuned Radio (STR)

TEA5757; TEA5759

QUICK REFERENCE DATA

| SYMBOL | PARAMETER | CONDITIONS | MIN. | TYP. | MAX. | UNIT |
|--------------------------------|---|---|------|------|------------------|--------------|
| V_{CC1} | supply voltage | | 2.5 | – | 12 | V |
| V_{CC2} | supply voltage for tuning | | – | – | 12 | V |
| V_{tune} | tuning voltage | | 0.7 | – | $V_{CC2} - 0.75$ | V |
| I_{CC1} | supply current | AM mode | 12 | 15 | 18 | mA |
| | | FM mode | 13 | 16 | 19 | mA |
| I_{DD} | supply current | AM mode | – | 3.3 | – | mA |
| | | FM mode | – | 2.7 | – | mA |
| I_{CC2} | supply current for tuning in preset mode (band-end to band-end) | | – | – | 640 | μ A |
| T_{amb} | operating ambient temperature | | –15 | – | +60 | $^{\circ}$ C |
| AM performance; note 1 | | | | | | |
| V_{10} | AF output voltage | $V_{i1} = 5$ mV | 36 | 45 | 70 | mV |
| V_{i1} | RF sensitivity input voltage | S/N = 26 dB | 40 | 55 | 70 | μ V |
| THD | total harmonic distortion | $V_{i1} = 1$ mV | – | 0.8 | 2.0 | % |
| FM performance; note 2 | | | | | | |
| V_{10} | AF output voltage | $V_{i5} = 5$ mV | 40 | 48 | 57 | mV |
| V_{i5} | RF sensitivity input voltage | $V_{10} = -3$ dB; $V_{10} = 0$ dB at $V_{i5} = 1$ mV | 0.4 | 1.2 | 3.8 | μ V |
| THD | total harmonic distortion | IF filter SFE10.7MS3A20K-A | – | 0.3 | 0.8 | % |
| MPX performance; note 3 | | | | | | |
| α_{CS} | channel separation | | 26 | 30 | – | dB |

Notes

- $V_{CC1} = 3$ V; $V_{CC2} = 12$ V; $V_{DDD} = 3$ V; $f_i = 1$ MHz; $m = 0.3$; $f_m = 1$ kHz; measured in Fig.9 with S1 in position A; S2 in position B; unless otherwise specified.
- $V_{CC1} = 3$ V; $V_{CC2} = 12$ V; $V_{DDD} = 3$ V; $f_i = 100$ MHz; $\Delta f_m = 22.5$ kHz; $f_m = 1$ kHz; measured in Fig.9 with S2 in position A; S3 in position A and S5 in position A; unless otherwise specified.
- $V_{CC1} = 3$ V; $V_{CC2} = 12$ V; $V_{DDD} = 3$ V; $V_{in3(L+R)} = 155$ mV; $V_{pilot} = 15.5$ mV; $f_i = 1$ kHz; measured in Fig.9 with S2 in position B; S3 in position B; unless otherwise specified.

Self Tuned Radio (STR)

TEA5757; TEA5759

BLOCK DIAGRAM

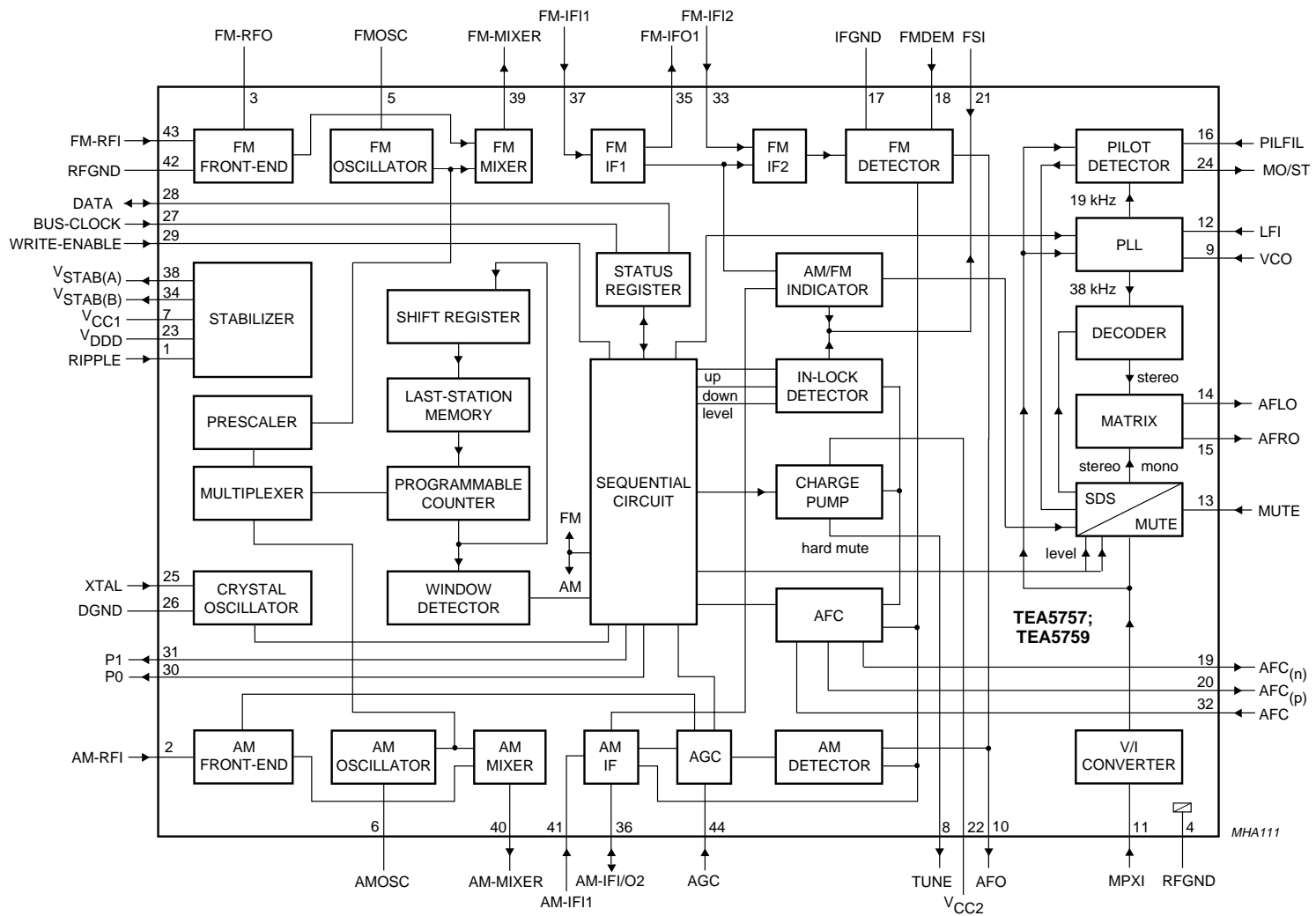

Fig.1 Block diagram.

Self Tuned Radio (STR)

TEA5757; TEA5759

PINNING

| SYMBOL | PIN | DESCRIPTION |
|----------------------|-----|---|
| RIPPLE | 1 | ripple capacitor input |
| AM-RFI | 2 | AM-RF input |
| FM-RFO | 3 | parallel tuned FM-RF circuit to ground |
| RFGND | 4 | RF ground and substrate |
| FMOSC | 5 | parallel tuned FM-oscillator circuit to ground |
| AMOSC | 6 | parallel tuned AM-oscillator circuit to ground |
| V _{CC1} | 7 | supply voltage |
| TUNE | 8 | tuning output current |
| VCO | 9 | voltage controlled oscillator input |
| AFO | 10 | AM/FM AF output (output impedance typical 5 k Ω) |
| MPXI | 11 | stereo decoder input (input impedance typical 150 k Ω) |
| LFI | 12 | loop-filter input |
| MUTE | 13 | mute input |
| AFLO | 14 | left channel output (output impedance typical 4.3 k Ω) |
| AFRO | 15 | right channel output (output impedance typical 4.3 k Ω) |
| PILFIL | 16 | pilot detector filter input |
| IFGND | 17 | ground of IF, detector and MPX stage |
| FMDEM | 18 | ceramic discriminator input |
| AFC _(n) | 19 | AFC negative output |
| AFC _(p) | 20 | AFC positive output |
| FSI | 21 | field-strength indicator |
| V _{CC2} | 22 | supply voltage for tuning |
| V _{DDD} | 23 | digital supply voltage |
| MO/ST | 24 | mono/stereo and tuning indication output |
| XTAL | 25 | crystal input |
| DGND | 26 | digital ground |
| BUS-CLOCK | 27 | bus-clock input |
| DATA | 28 | bus data input/output |
| WRITE-ENABLE | 29 | bus write-enable input |
| P0 | 30 | programmable output port (P0) |
| P1 | 31 | programmable output port (P1) |
| AFC | 32 | 450 kHz LC-input circuit |
| FM-IFI2 | 33 | FM-IF input 2 (input impedance typical 330 Ω) |
| V _{STAB(B)} | 34 | internal stabilized supply voltage (B) |
| FM-IFO1 | 35 | FM-IF output 1 (input impedance typical 330 Ω) |
| AM-IFI/O2 | 36 | input/output to IFT; output: current source |
| FM-IFI1 | 37 | FM-IF input 1 (input impedance typical 330 Ω) |
| V _{STAB(A)} | 38 | internal stabilized supply voltage (A) |
| FM-MIXER | 39 | ceramic filter output (output impedance typical 330 Ω) |
| AM-MIXER | 40 | open-collector output to IFT |

Self Tuned Radio (STR)

TEA5757; TEA5759

| SYMBOL | PIN | DESCRIPTION |
|--------|-----|--|
| AM-IF1 | 41 | IFT or ceramic filter input (input impedance typical 3 kΩ) |
| RFGND | 42 | FM-RF ground |
| FM-RFI | 43 | FM-RF aerial input (input impedance typical 40 Ω) |
| AGC | 44 | AGC capacitor input |

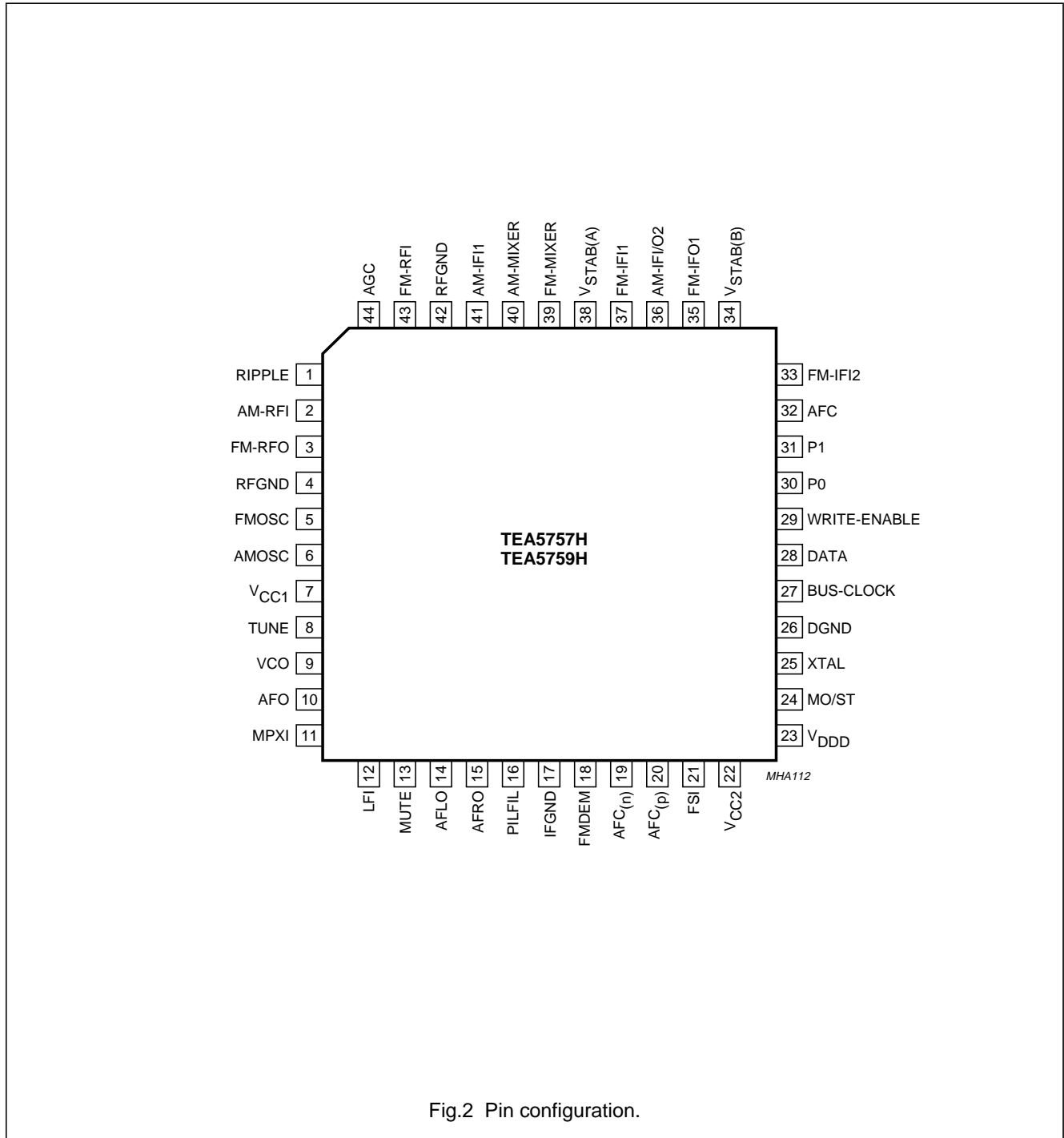

Fig.2 Pin configuration.

Self Tuned Radio (STR)

TEA5757; TEA5759

FUNCTIONAL DESCRIPTION

The TEA5757; TEA5759 is an integrated AM/FM stereo radio circuit including digital tuning and control functions.

The radio

The AM circuit incorporates a double balanced mixer, a one-pin low-voltage oscillator (up to 30 MHz) and is designed for distributed selectivity.

The AM input is designed to be connected to the top of a tuned circuit. AGC controls the IF amplification and for large signals it lowers the input impedance of the AM front-end.

The first AM selectivity can be an IF-Tank (IFT) as well as an IFT combined with a ceramic filter; the second one is an IFT.

The FM circuit incorporates a tuned RF stage, a double balanced mixer, a one-pin oscillator and is designed for distributed IF ceramic filters. The FM quadrature detector uses a ceramic resonator.

The PLL stereo decoder incorporates a signal dependent stereo-blend circuit and a soft-mute circuit.

Tuning

The tuning-concept of Self Tuned Radio (STR) is based on FUZZY LOGIC: it mimics hand tuning (hand tuning is a combination of coarse and fine tuning to the qualitatively best frequency position). As a consequence the tuning system is very fast.

The tuning algorithm, which is controlled by the sequential circuit (see Fig.1), is completely integrated; so there are only a few external components needed.

The bus and the microcontroller can be kept very simple. The bus only consists of three wires (BUS-CLOCK, DATA and WRITE-ENABLE). The microcontroller must basically give two instructions:

- Preset operation
- Search operation.

PRESET OPERATION

In preset mode, the microcontroller has to load information such as frequency band, frequency and mono/stereo. This information has to be sent via the bus to the STR. The internal algorithm controls the tuning sequence as follows:

1. The information is loaded into a shift register, a last-station memory and the counter.
2. The Automatic Frequency Control (AFC) is switched-off.
3. The counter starts counting the frequency and the tuning voltage is varied until the desired frequency roughly equals the real frequency.
4. The AFC is then switched-on and the counter is switched-off.
5. The real frequency is more precisely tuned to the desired frequency.

After the AFC has tuned the real frequency to the desired frequency an in-lock signal can be generated. In order to get a reliable in-lock signal, there are two parameters measured: the field strength and the S-curve. The field strength indicates the strength of the station and by looking at the S-curve the system can distinguish false in-locks from real in-locks (false in-locks occur on the wrong slope of the S-curve).

In the event of fading or pulling the in-lock signal becomes logic 0 and the synthesizer will be switched-on again and the algorithm will be repeated.

SEARCH OPERATION

During a search operation, the only action the microcontroller has to take is: sending the desired band plus the direction and the search sensitivity level to the STR. The search operation is performed by the charge pump until an in-lock signal is generated (combination of measuring the field strength and the S-curve). The AFC then fine tunes to the station. The frequency belonging to the found station will be counted by the counter and written into the last-station memory and the shift register of the counter. At this time the frequency is available in the shift register and can be read by the microcontroller.

The microcontroller decides whether the frequency is within the desired frequency band. If so, this frequency can be stored under a preset and if not, a new search action should be started.

Self Tuned Radio (STR)

TEA5757; TEA5759

Description of the bus

The TEA5757; TEA5759 radio has a bus which consists of three wires, as shown in Table 1.

Table 1 Bus signals

| SIGNAL | DESCRIPTION | PIN |
|--------------|-----------------------------|-----|
| BUS-CLOCK | software driven clock input | 27 |
| DATA | data input/output | 28 |
| WRITE-ENABLE | write/read-input | 29 |

These three signals, together with the mono/stereo pin (MO/ST; pin 24), communicate with the microcontroller. The mono/stereo indicator has two functions, which are controlled by the BUS-CLOCK, as shown in Table 2.

Table 2 Bus-clock functions

| BUS-CLOCK | MO/ST (PIN 24) | RESULT |
|-----------|----------------|-----------|
| LOW | LOW | stereo |
| LOW | HIGH | mono |
| HIGH | LOW | tuned |
| HIGH | HIGH | not tuned |

The TEA5757; TEA5759 has a 25-bit shift register; see Table 3 for an explanation of the shift register bits.

If in search mode no transmitter can be found, all frequency bits of the shift register are set to logic 1.

The bus protocol is depicted in Figs 3 and 4.

Table 3 Explanation of the shift register bits

| BIT | DESCRIPTION | LOGIC STATE | RESULT |
|-------------------|-------------------------|-------------|--|
| S.24 (MSB) | search start/end | 0 | after a search when a station is found or after a preset |
| | | 1 | during the search action |
| D.23 | search up/down | 0 | indicates if the radio has to search down |
| | | 1 | indicates if the radio has to search up |
| M.22 | mono/stereo | 0 | stereo is allowed |
| | | 1 | mono is required (radio switched to forced mono) |
| B0.21 | band | see Table 4 | selects FM/MW/LW/SW band |
| B1.20 | band | see Table 4 | selects FM/MW/LW/SW band |
| P0.19 | port | note 1 | user programmable bits which e.g. can be used as band switch driver |
| P1.18 | port | note 1 | user programmable bits which e.g. can be used as band switch driver |
| S0.17 | search-level of station | see Table 5 | determines the locking field strength during an automatic search, automatic store or manual search |
| S1.16 | search-level of station | see Table 5 | determines the locking field strength during an automatic search, automatic store or manual search |
| 15 | dummy | – | buffer |
| F.14 to F.0 (LSB) | frequency | – | determine the tuning frequency of the radio; see Table 6 for the bit values |

Note

1. The output pins 30 and 31 can drive currents up to 5 mA; bits 19 (P0) and 18 (P1) control the output voltage of the control pins P0 (pin 30) and P1 (pin 31):
 - a) Bit 19 (P0) LOW sets P0 (pin 30) to LOW.
 - b) Bit 19 (P0) HIGH sets P0 (pin 30) to HIGH.
 - c) Bit 18 (P1) LOW sets P1 (pin 31) to LOW.
 - d) Bit 18 (P1) HIGH sets P1 (pin 31) to HIGH.

Self Tuned Radio (STR)

TEA5757; TEA5759

Table 4 Truth table for bits 21 and 20

| B0 | B1 | BAND SELECT |
|----|----|-------------|
| 0 | 0 | FM |
| 0 | 1 | MW |
| 1 | 0 | LW |
| 1 | 1 | SW |

Table 5 Truth table for bits 16 and 17

| S1 | S0 | SIGNAL RECEPTION | |
|----|----|-------------------------|-------------------------|
| | | FM (μV) | AM (μV) |
| 0 | 0 | >5 | >28 |
| 0 | 1 | >10 | >40 |
| 1 | 0 | >30 | >63 |
| 1 | 1 | >150 | >1000 |

Table 6 Values for bits 14 to 0

| BIT | BIT VALUE | FM VALUE ⁽¹⁾ (kHz) | AM VALUE ⁽²⁾ (kHz) |
|-----|-----------|-------------------------------------|-------------------------------------|
| 14 | 2^{14} | – | 16384 |
| 13 | 2^{13} | 102400 | 8192 |
| 12 | 2^{12} | 51200 | 4096 |
| 11 | 2^{11} | 25600 | 2048 |
| 10 | 2^{10} | 12800 | 1024 |
| 9 | 2^9 | 6400 | 512 |
| 8 | 2^8 | 3200 | 256 |
| 7 | 2^7 | 1600 | 128 |
| 6 | 2^6 | 800 | 64 |
| 5 | 2^5 | 400 | 32 |
| 4 | 2^4 | 200 | 16 |
| 3 | 2^3 | 100 | 8 |
| 2 | 2^2 | 50 | 4 |
| 1 | 2^1 | 25 | 2 |
| 0 | 2^0 | 12.5 | 1 |

Notes

- FM value of the affected oscillators:
 - FM VALUE = FM-RF + FM-IF (for TEA5757).
 - FM VALUE = FM-RF – FM-IF (for TEA5759).
- AM value of the affected oscillators:
AM VALUE = AM-RF + AM-IF.

Self Tuned Radio (STR)

TEA5757; TEA5759

READING DATA

While WRITE-ENABLE is LOW data can be read by the microcontroller. At a rising edge of the BUS-CLOCK, data is shifted out of the register. This data is available from the point where the BUS-CLOCK is HIGH until the next rising edge of the BUS-CLOCK occurs (see Fig.3).

To read the entire shift register 24 clock pulses are necessary.

WRITING DATA

While WRITE-ENABLE is HIGH the microcontroller can transmit data to the TEA5757; TEA5759 (hard mute is active). At a rising edge of the BUS-CLOCK, the register shifts and accepts one bit into LSB. At clock LOW the microcontroller writes data (see Fig.4).

To write the entire shift register 25 clock pulses are necessary.

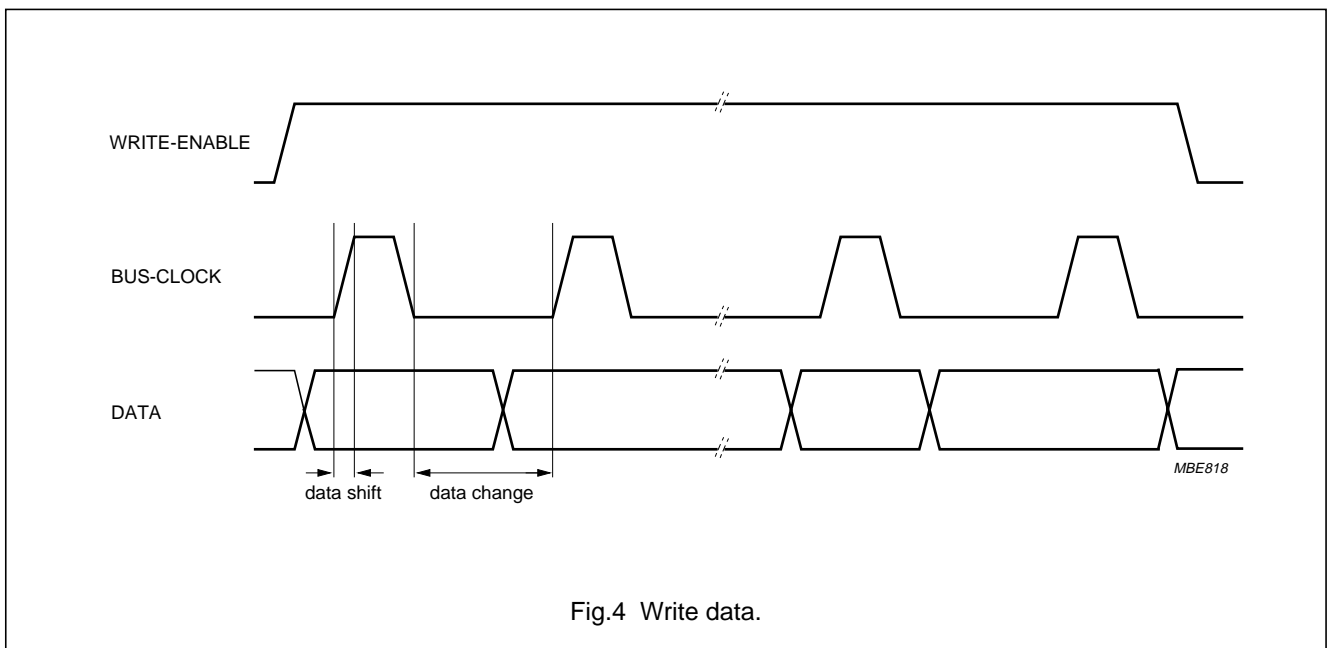
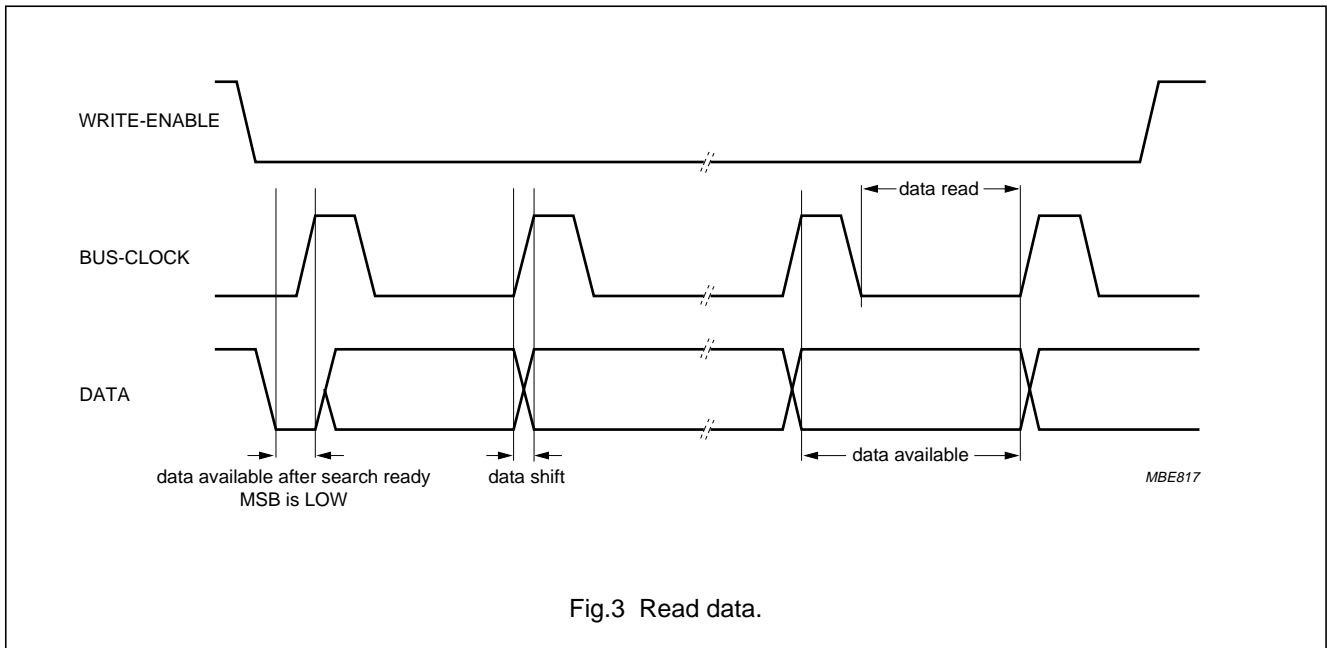

Self Tuned Radio (STR)

TEA5757; TEA5759

BUS TIMING

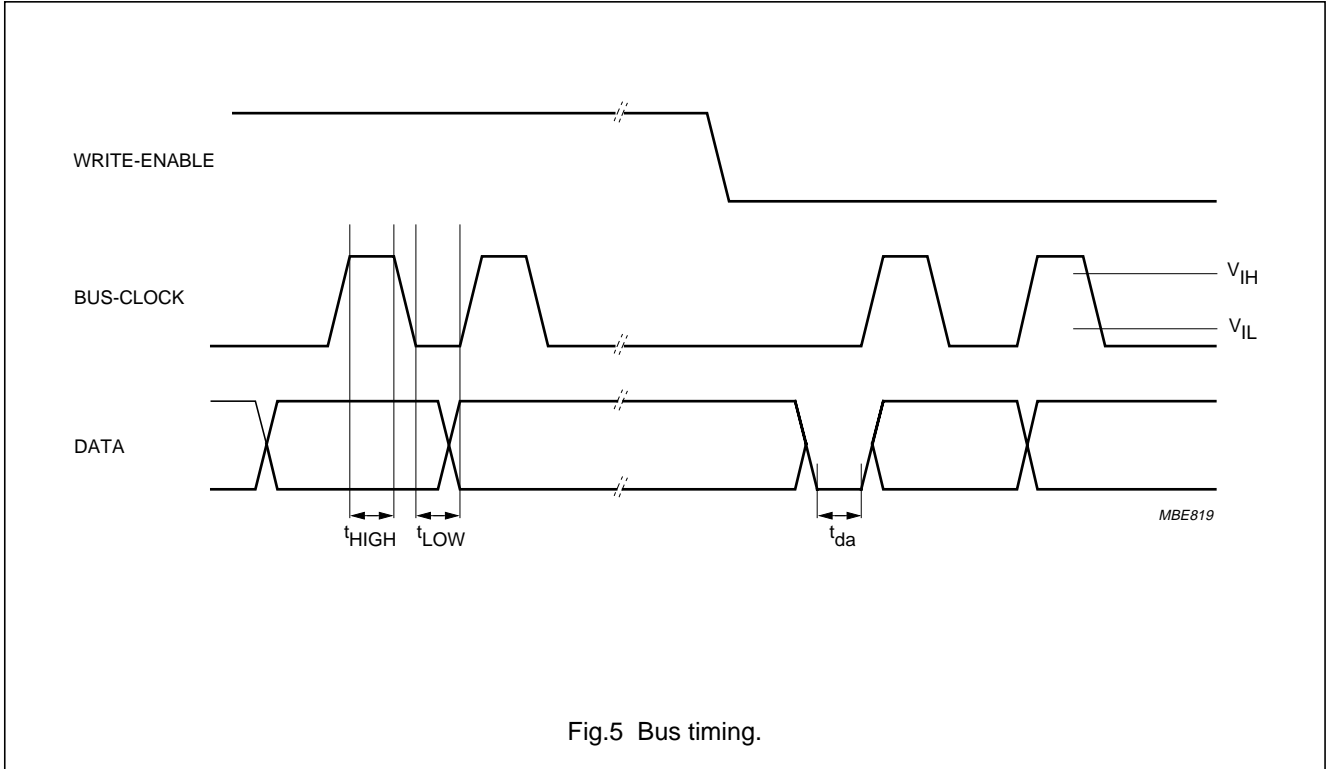

Fig.5 Bus timing.

Table 7 Digital inputs

| SYMBOL | PARAMETER | MIN. | MAX. | UNIT |
|-----------------------|---|------|------|---------|
| Digital inputs | | | | |
| V_{IH} | HIGH level input voltage | 1.4 | – | V |
| V_{IL} | LOW level input voltage | – | 0.6 | V |
| Timing | | | | |
| f_{clk} | clock input | – | 300 | kHz |
| t_{HIGH} | clock HIGH time | 1.67 | – | μ s |
| t_{LOW} | clock LOW time | 1.67 | – | μ s |
| t_{da} | shift register available after 'search ready' | – | 14 | μ s |

Self Tuned Radio (STR)

TEA5757; TEA5759

LIMITING VALUES

In accordance with the Absolute Maximum Rating System (IEC 134).

| SYMBOL | PARAMETER | CONDITIONS | MIN. | MAX. | UNIT |
|-----------|-------------------------------------|--------------------------|------|------|------|
| V_{CC1} | supply voltage | | 0 | 13.2 | V |
| P_{tot} | total power dissipation | $T_{amb} = 70\text{ °C}$ | – | 250 | mW |
| T_{stg} | storage temperature | | –65 | +150 | °C |
| T_{amb} | operating ambient temperature | | –15 | +60 | °C |
| T_j | operating junction temperature | | –15 | +150 | °C |
| V_{es} | electrostatic handling for all pins | note 1 | – | ±200 | V |

Note

1. Charge device model; equivalent to discharging a 200 pF capacitor via a 0 Ω series resistor.

THERMAL CHARACTERISTICS

| SYMBOL | PARAMETER | VALUE | UNIT |
|---------------|---|-------|------|
| $R_{th\ j-a}$ | thermal resistance from junction to ambient in free air | 65 | K/W |

Self Tuned Radio (STR)

TEA5757; TEA5759

CHARACTERISTICS

$V_{CC1} = 3\text{ V}$; $T_{amb} = 25\text{ °C}$; unless otherwise specified.

| SYMBOL | PARAMETER | CONDITIONS | MIN. | TYP. | MAX. | UNIT |
|----------------------|---|-----------------------|-------|------|------------------|---------------|
| V_{CC1} | supply voltage | | 2.5 | – | 12 | V |
| V_{CC2} | supply voltage for tuning | | – | – | 12 | V |
| V_{DDD} | supply voltage for digital part | | 2.5 | – | 12 | V |
| V_{tune} | tuning voltage | | 0.7 | – | $V_{CC2} - 0.75$ | V |
| I_{CC2} | supply current for tuning in preset mode (band-end to band-end) | | – | – | 640 | μA |
| $f_{BUS-CLOCK(max)}$ | maximum BUS-CLOCK frequency | | – | – | 300 | kHz |
| I_{CC1} | current consumption during acquisition of V_{CC1} | AM mode | 12 | 15 | 18 | mA |
| | | FM mode | 12.5 | 15.5 | 18.5 | mA |
| I_{DD} | current consumption during acquisition of I_{DD} | AM mode | – | 4.8 | – | mA |
| | | FM mode | – | 5.5 | – | mA |
| I_{CC1} | current consumption after acquisition of V_{CC1} | AM mode | 12 | 15 | 18 | mA |
| | | FM mode | 13 | 16 | 19 | mA |
| I_{DD} | current consumption after acquisition of I_{DD} | AM mode | – | 3.2 | – | mA |
| | | FM mode | – | 2.7 | – | mA |
| t_{search} | synthesizer auto-search time for empty band | FM mode | – | – | 10 | s |
| t_{acq} | synthesizer preset acquisition time between two band limits | FM | – | 100 | – | ms |
| | | MW | – | 100 | – | ms |
| | | LW | – | 200 | – | ms |
| | | SW | – | 500 | – | ms |
| f_{band} | frequency band range of the synthesizer | AM mode | 0.144 | – | 30 | MHz |
| | | FM mode | 50 | – | 150 | MHz |
| Δf_{FM} | AFC inaccuracy of FM | | – | – | 1 | kHz |
| Δf_{AM} | AFC inaccuracy of AM | | – | – | 100 | Hz |
| $I_{P0(sink)}$ | sink current of software programmable output P0 | $V_{30} = 3\text{ V}$ | 4 | 6 | – | mA |
| $I_{P1(sink)}$ | sink current of software programmable output P1 | $V_{31} = 3\text{ V}$ | 4 | 6 | – | mA |
| $I_{P0(source)}$ | source current of software programmable output P0 | $V_{30} = 0\text{ V}$ | 9 | 11 | – | mA |
| $I_{P1(source)}$ | source current of software programmable output P1 | $V_{31} = 0\text{ V}$ | 9 | 11 | – | mA |

Self Tuned Radio (STR)

TEA5757; TEA5759

AM CHARACTERISTICS

Input frequency (f_i) = 1 MHz; $m = 0.3$; $f_{\text{mod}} = 1$ kHz; measured in test circuit at pin 10 (see Fig.9); S2 in position B; V_{i1} measured at input of matching network at pin 2; matching network adjusted to maximum output voltage at low input level; $V_{i(n)}$ refers to test circuit (see Fig.9); V_n refers to pin voltages; unless otherwise specified.

| SYMBOL | PARAMETER | CONDITIONS | MIN. | TYP. | MAX. | UNIT |
|----------------|---|---|------|------|------|---------|
| V_{10} | AF output voltage | $V_{i1} = 5$ mV | 36 | 45 | 70 | mV |
| V_{i1} | RF sensitivity | S/N = 26 dB | 40 | 55 | 70 | μ V |
| V_{i1} | large signal voltage handling capacity | $m = 0.8$; THD $\leq 8\%$ | 150 | 300 | – | mV |
| PSSR | power supply ripple rejection $\left(\frac{V_{10}}{\Delta V_7} \right)$ | $\Delta V_7 = 100$ mV (RMS); 100 Hz; $V_7 = 3.0$ V | – | –47 | – | dB |
| I_i | input current (pin 2) | $V_{44} = 0.2$ V | – | 0 | – | μ A |
| C_i | input capacitance (pin 2) | $V_{44} = 0.2$ V | – | – | 4 | pF |
| G_c | front-end conversion gain | $V_{44} = 0.2$ V | 5 | 10 | 14 | dB |
| | | $V_{44} = 0.9$ V | –26 | –14 | 0 | dB |
| S/N | signal-to-noise ratio | | – | 50 | – | dB |
| THD | total harmonic distortion | $V_{i1} = 1$ mV | – | 0.8 | 2.0 | % |
| α_{450} | IF suppression | $V_{10} = 30$ mV | – | 56 | – | dB |

FM CHARACTERISTICS

Input frequency (f_i) = 100 MHz; $\Delta f = 22.5$ kHz; $f_{\text{mod}} = 1$ kHz; measured in test circuit (see Fig.9) at pin 10; S2 in position B; $V_{i(n)}$ refers to test circuit (see Fig.9); V_n refers to pin voltages; unless otherwise specified.

| SYMBOL | PARAMETER | CONDITIONS | MIN. | TYP. | MAX. | UNIT |
|----------|---|---|------|------|------|---------|
| V_{10} | AF output voltage | $V_{i5} = 1$ mV | 40 | 48 | 57 | mV |
| V_{i5} | RF sensitivity | S/N = 26 dB | 1 | 2 | 3.8 | μ V |
| V_{i5} | RF limiting sensitivity | $V_{10} = -3$ dB; $V_{10} = 0$ dB at $V_{i5} = 1$ mV | 0.4 | 1.2 | 3.8 | μ V |
| V_{i5} | large signal voltage handling capacity | THD < 5% | – | 500 | – | mV |
| PSSR | power supply ripple rejection $\left(\frac{V_{10}}{\Delta V_7} \right)$ | $\Delta V_7 = 100$ mV (RMS); 100 Hz; $V_7 = 3.0$ V | –44 | – | – | dB |
| G_c | front-end conversion gain $\left(\frac{V_{37}}{V_{i5}} \right)$ | | 12 | 18 | 22 | dB |
| S/N | signal-to-noise ratio | $V_{i5} = 1$ mV | – | 62 | – | dB |
| THD | total harmonic distortion | IF filter SFE10.7MS3A20K-A | – | 0.3 | 0.8 | % |

Self Tuned Radio (STR)

TEA5757; TEA5759

STEREO DECODER CHARACTERISTICS

$V_{i3(L+R)} = 155 \text{ mV}$; $V_{\text{pilot}} = 15.5 \text{ mV}$; $f = 1 \text{ kHz}$; apply unmodulated RF-signal of 100 mV to front-end to set radio to maximum channel separation; soft mute off (S4 in position A); unless otherwise specified.

| SYMBOL | PARAMETER | CONDITIONS | MIN. | TYP. | MAX. | UNIT |
|--------------------------|----------------------------------|---|------|------|------|------|
| $V_{14/15}$ | AF output voltage | | – | 160 | – | mV |
| $V_{\text{pilot}(s)}$ | switch to stereo | | – | 8 | 12 | mV |
| $V_{\text{pilot}(m)}$ | switch to mono | | 2 | 5 | – | mV |
| $V_{\text{AF-L}}/V_{i3}$ | MPX voltage gain | | –1.5 | – | +1.5 | dB |
| S/N | signal-to-noise ratio | $V_{\text{pilot}} = 15.5 \text{ mV}$ (stereo) | – | 74 | – | dB |
| THD | total harmonic distortion | | – | 0.5 | 1.0 | % |
| α_{cs} | channel separation | | 26 | 30 | – | dB |
| α_{19} | carrier and harmonic suppression | 19 kHz (200 mV) = 0 dB | 27 | 32 | – | dB |
| α_{38} | | 38 kHz | 16 | 21 | – | dB |
| α | stereo-blend | $V_{i5} = 200 \mu\text{V}$ | 22 | 30 | – | dB |
| | | $V_{i5} = 20 \mu\text{V}$ | – | 1 | 2 | dB |
| mute(s) | soft mute depth | $V_{i5} = 3 \mu\text{V}$; $V_{14} = V_{15}$ | –1 | 0 | – | dB |
| | | $V_{i5} = 1 \mu\text{V}$; $V_{14} = V_{15}$ | – | –6 | –10 | dB |

TUNING CHARACTERISTICS

| SYMBOL | PARAMETER | CONDITIONS | MIN. | TYP. | MAX. | UNIT |
|-----------------------|---|---|------|------|------|---------------|
| V_{FM} | FM voltage levels | $\alpha_{-3 \text{ dB}}$ -point at $V_{i5} = 2 \mu\text{V}$ | | | | |
| | high (auto-store/search) | $S_0 = 1$; $S_1 = 1$ | 60 | 150 | 500 | μV |
| | medium (auto-store/search) | $S_0 = 0$; $S_1 = 1$ | 10 | 30 | 55 | μV |
| | low (auto-store/search) | $S_0 = 1$; $S_1 = 0$ | 4 | 10 | 20 | μV |
| | nominal (preset mode/tuning indication) | $S_0 = 0$; $S_1 = 0$ | 3 | 5 | 9 | μV |
| V_{AM} | AM voltage levels | $\alpha_{-3 \text{ dB}}$ -point at $V_{i5} = 2 \mu\text{V}$ | | | | |
| | high (auto-store/search) | $S_0 = 1$; $S_1 = 1$ | 400 | 1000 | 2500 | μV |
| | medium (auto-store/search) | $S_0 = 0$; $S_1 = 1$ | 50 | 63 | 80 | μV |
| | low (auto-store/search) | $S_0 = 1$; $S_1 = 0$ | 32 | 40 | 50 | μV |
| | nominal (preset mode/tuning indication) | $S_0 = 0$; $S_1 = 0$ | 25 | 28 | 40 | μV |
| $V_{\text{AFC(off)}}$ | AFC voltage off mode | $\alpha_{-3 \text{ dB}}$ -point at $V_{i5} = 2 \mu\text{V}$ | | | | |
| | | FM mode | – | 3 | – | μV |
| | | AM mode | – | 25 | – | μV |
| mute(h) | hard mute | WRITE-ENABLE = HIGH | – | 60 | – | dB |

Self Tuned Radio (STR)

TEA5757; TEA5759

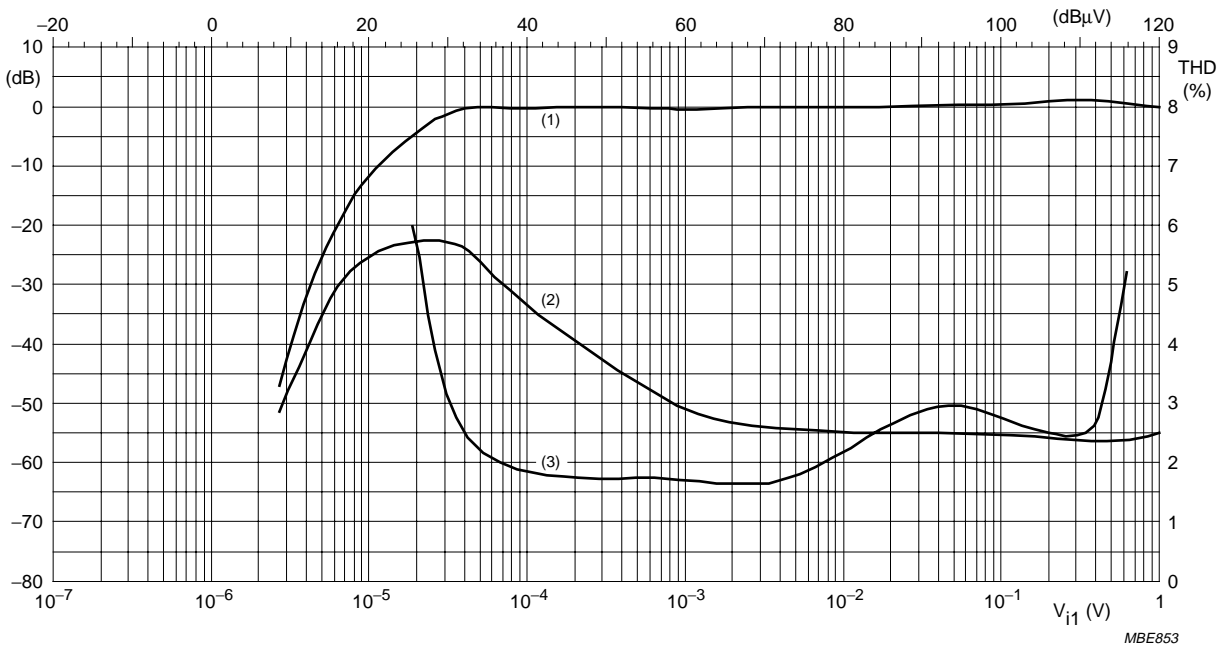

- (1) Audio signal.
- (2) Noise.
- (3) Harmonic distortion.

Fig.6 AM mode.

Self Tuned Radio (STR)

TEA5757; TEA5759

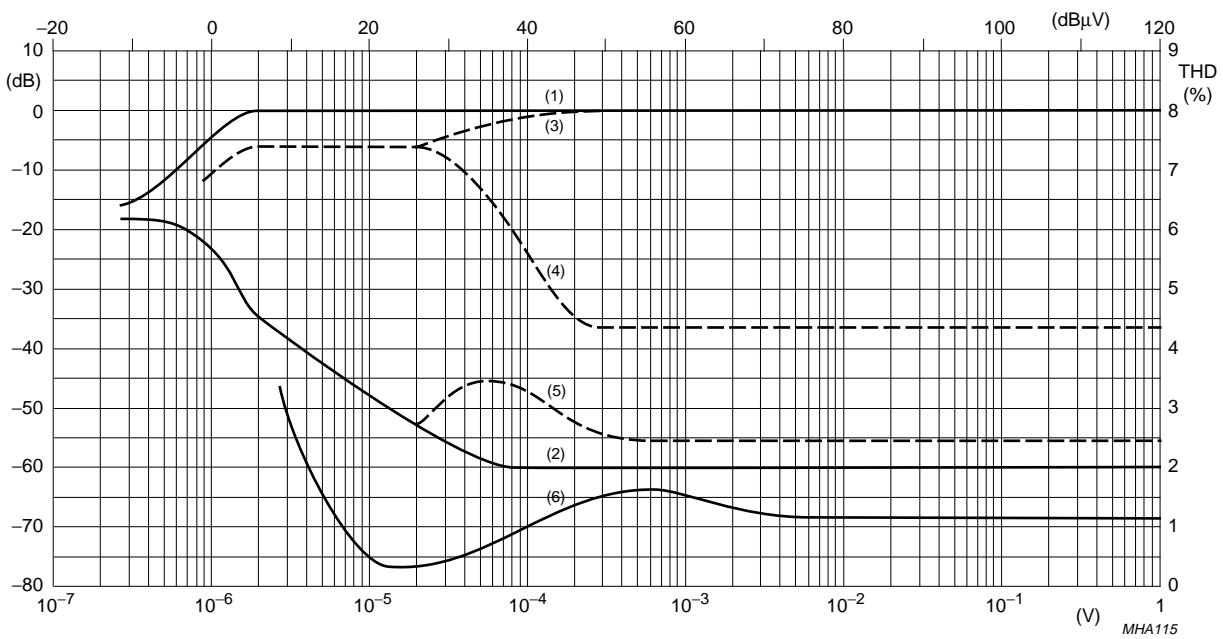

- (1) Mono signal.
- (2) Noise in mono mode.
- (3) Left channel with modulation left.
- (4) Right channel with modulation left.
- (5) Noise in stereo mode.
- (6) Harmonic distortion.

Fig.7 FM mode.

Self Tuned Radio (STR)

TEA5757; TEA5759

INTERNAL CIRCUITRY

Table 8 Equivalent pin circuits and pin voltages

| PIN NO. | PIN SYMBOL | DC VOLTAGE (V) | | EQUIVALENT CIRCUIT |
|---------|------------|----------------|-----|--------------------|
| | | AM | FM | |
| 1 | RIPPLE | 2.1 | 2.1 | <p>MBE821</p> |
| 2 | AM-RFI | 0 | 0 | <p>MBE822</p> |
| 3 | FM-RFO | 0 | 0 | <p>MHA105</p> |
| 4 | RFGND | 0 | 0 | |
| 5 | FMOSC | 0 | 0 | <p>MBE823</p> |

Self Tuned Radio (STR)

TEA5757; TEA5759

| PIN NO. | PIN SYMBOL | DC VOLTAGE (V) | | EQUIVALENT CIRCUIT |
|---------|------------------|----------------|------|--------------------|
| | | AM | FM | |
| 6 | AMOSC | 0 | 0 | |
| 7 | V _{CC1} | 3.0 | 3.0 | |
| 8 | TUNE | - | - | |
| 9 | VCO | 1.3 | 0.95 | |
| 10 | AFO | 0.6 | 0.7 | |

Self Tuned Radio (STR)

TEA5757; TEA5759

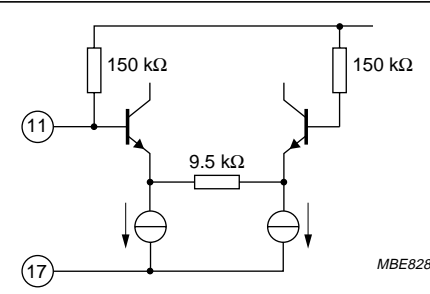
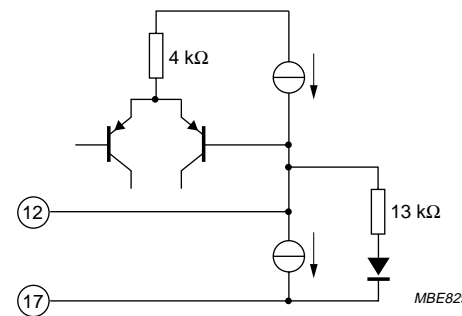
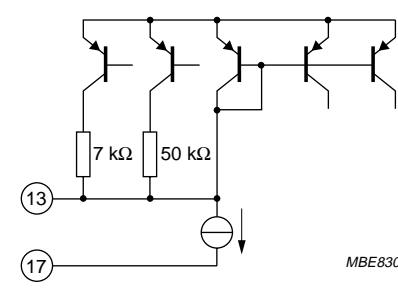
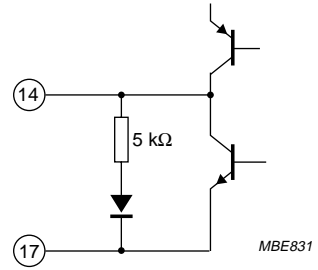
| PIN NO. | PIN SYMBOL | DC VOLTAGE (V) | | EQUIVALENT CIRCUIT |
|---------|------------|----------------|------|--|
| | | AM | FM | |
| 11 | MPXI | 1.23 | 1.23 |  <p>MBE828</p> |
| 12 | LFI | 0.1 | 0.8 |  <p>MBE829</p> |
| 13 | MUTE | 0.7 | 0.7 |  <p>MBE830</p> |
| 14 | AFLO | 0.65 | 0.65 |  <p>MBE831</p> |

Self Tuned Radio (STR)

TEA5757; TEA5759

| PIN NO. | PIN SYMBOL | DC VOLTAGE (V) | | EQUIVALENT CIRCUIT |
|---------|--------------------|----------------|------|--------------------|
| | | AM | FM | |
| 15 | AFRO | 0.65 | 0.65 | |
| 16 | PILFIL | 0.95 | 0.95 | |
| 17 | IFGND | 0 | 0 | |
| 18 | FMDEM | - | 1.0 | |
| 19 | AFC _(n) | - | - | |

Self Tuned Radio (STR)

TEA5757; TEA5759

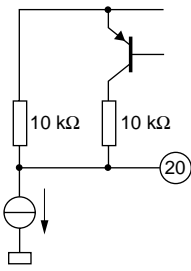
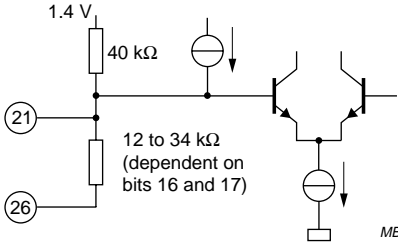
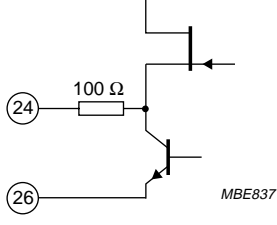
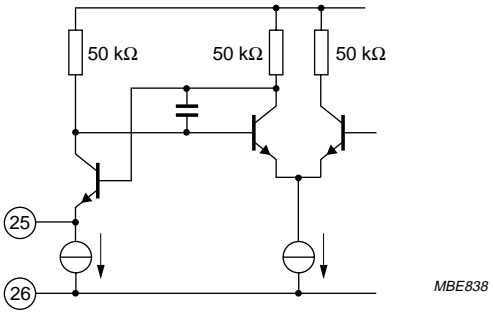
| PIN NO. | PIN SYMBOL | DC VOLTAGE (V) | | EQUIVALENT CIRCUIT |
|---------|--------------------|----------------|-----|--|
| | | AM | FM | |
| 20 | AFC _(p) | - | - |  <p>MHA107</p> |
| 21 | FSI | - | - |  <p>MBE836</p> |
| 22 | V _{CC2} | - | - | |
| 23 | V _{DDD} | 3.0 | 3.0 | |
| 24 | MO/ST | - | - |  <p>MBE837</p> |
| 25 | XTAL | - | - |  <p>MBE838</p> |
| 26 | DGND | 0 | 0 | |

Self Tuned Radio (STR)

TEA5757; TEA5759

| PIN NO. | PIN SYMBOL | DC VOLTAGE (V) | | EQUIVALENT CIRCUIT |
|---------|--------------|----------------|----|--------------------|
| | | AM | FM | |
| 27 | BUS-CLOCK | - | - | |
| 28 | DATA | - | - | |
| 29 | WRITE-ENABLE | - | - | |
| 30 | P0 | - | - | |
| 31 | P1 | - | - | |

Self Tuned Radio (STR)

TEA5757; TEA5759

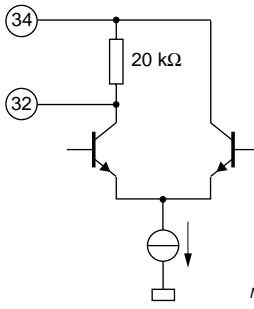
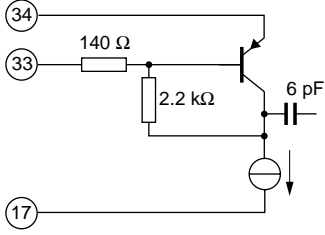
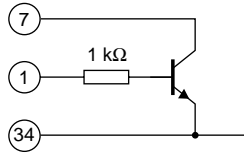
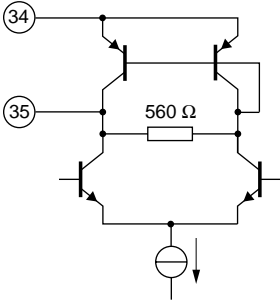
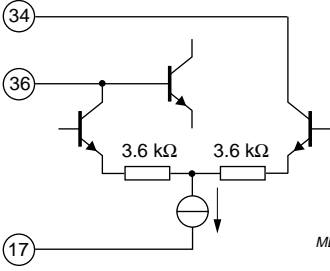
| PIN NO. | PIN SYMBOL | DC VOLTAGE (V) | | EQUIVALENT CIRCUIT |
|---------|----------------------|----------------|------|--|
| | | AM | FM | |
| 32 | AFC | - | - |  <p>MBE842</p> |
| 33 | FM-IFI2 | - | 0.73 |  <p>MBE843</p> |
| 34 | V _{STAB(B)} | 1.4 | 1.4 |  <p>MBE844</p> |
| 35 | FM-IFO1 | - | 0.69 |  <p>MBE845</p> |
| 36 | AM-IFI/O2 | 1.4 | 1.4 |  <p>MBE846</p> |

Self Tuned Radio (STR)

TEA5757; TEA5759

| PIN NO. | PIN SYMBOL | DC VOLTAGE (V) | | EQUIVALENT CIRCUIT |
|---------|----------------------|----------------|------|--------------------|
| | | AM | FM | |
| 37 | FM-IF11 | — | 0.73 | |
| 38 | V _{STAB(A)} | 1.4 | 1.4 | |
| 39 | FM-MIXER | — | 1.0 | |
| 40 | AM-MIXER | 1.4 | 1.4 | |
| 41 | AM-IF11 | 1.4 | 1.4 | |

Self Tuned Radio (STR)

TEA5757; TEA5759

| PIN NO. | PIN SYMBOL | DC VOLTAGE (V) | | EQUIVALENT CIRCUIT |
|---------|------------|----------------|------|--------------------|
| | | AM | FM | |
| 42 | RFGND | 0 | 0 | |
| 43 | FM-RFI | - | 0.73 | |
| 44 | AGC | 0.1 | 0.7 | |

Self Tuned Radio (STR)

TEA5757; TEA5759

TEST AND APPLICATION INFORMATION

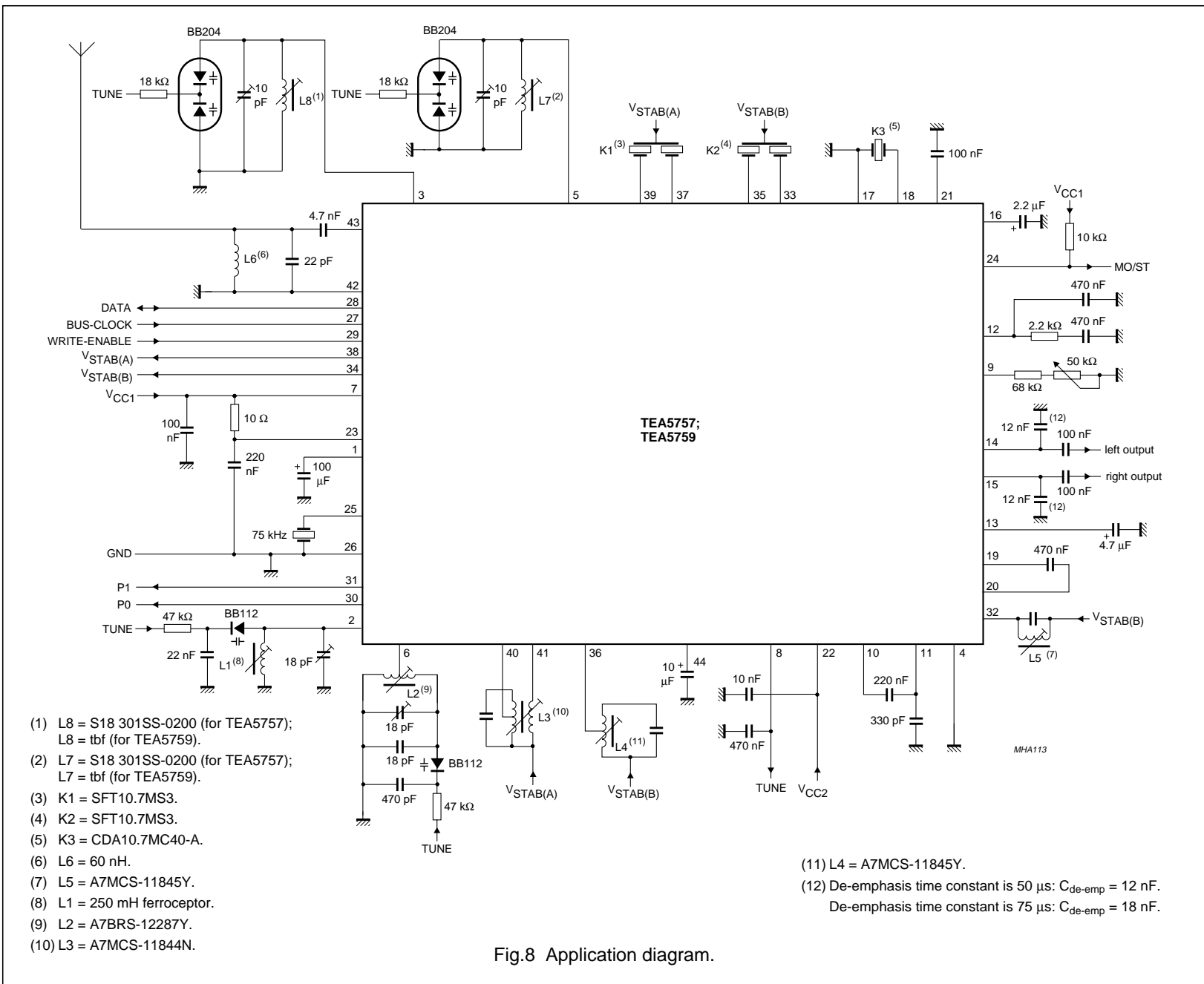
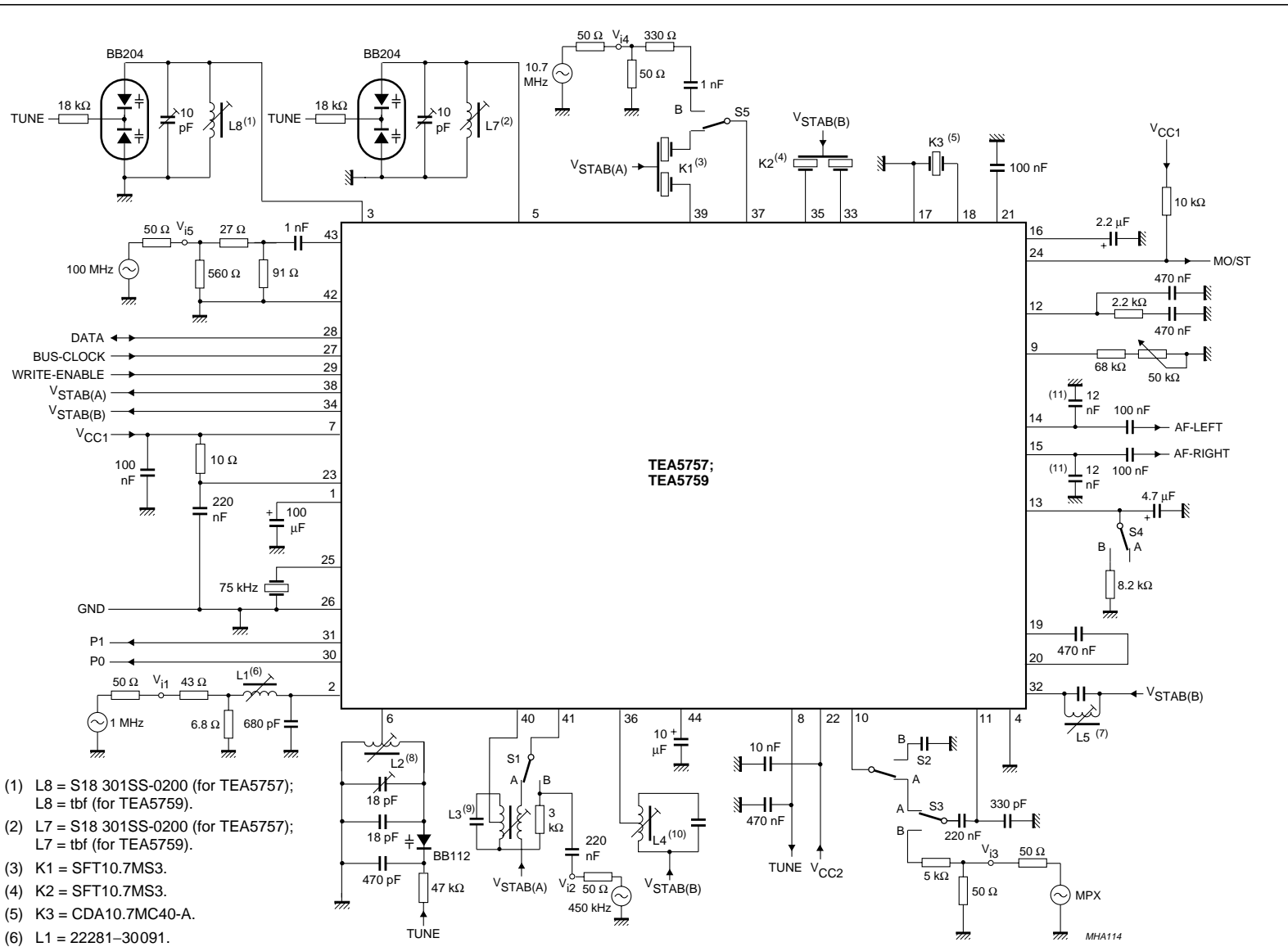

Fig.8 Application diagram.

Self Tuned Radio (STR)

TEA5757; TEA5759



- (1) L8 = S18 301SS-0200 (for TEA5757);
L8 = tbf (for TEA5759).
- (2) L7 = S18 301SS-0200 (for TEA5757);
L7 = tbf (for TEA5759).
- (3) K1 = SFT10.7MS3.
- (4) K2 = SFT10.7MS3.
- (5) K3 = CDA10.7MC40-A.
- (6) L1 = 22281-30091.
- (7) L5 = A7MCS-11845Y.
- (8) L2 = A7BRS-12287Y.
- (9) L3 = A7MCS-11844N.
- (10) L4 = A7MCS-11845Y.

(11) De-emphasis time constant is 50 μs: C_{de-emp} = 12 nF.
De-emphasis time constant is 75 μs: C_{de-emp} = 18 nF.

Fig.9 Test circuit.

Self Tuned Radio (STR)

TEA5757; TEA5759

PACKAGE OUTLINE

QFP44: plastic quad flat package; 44 leads (lead length 1.3 mm); body 10 x 10 x 1.75 mm

SOT307-2

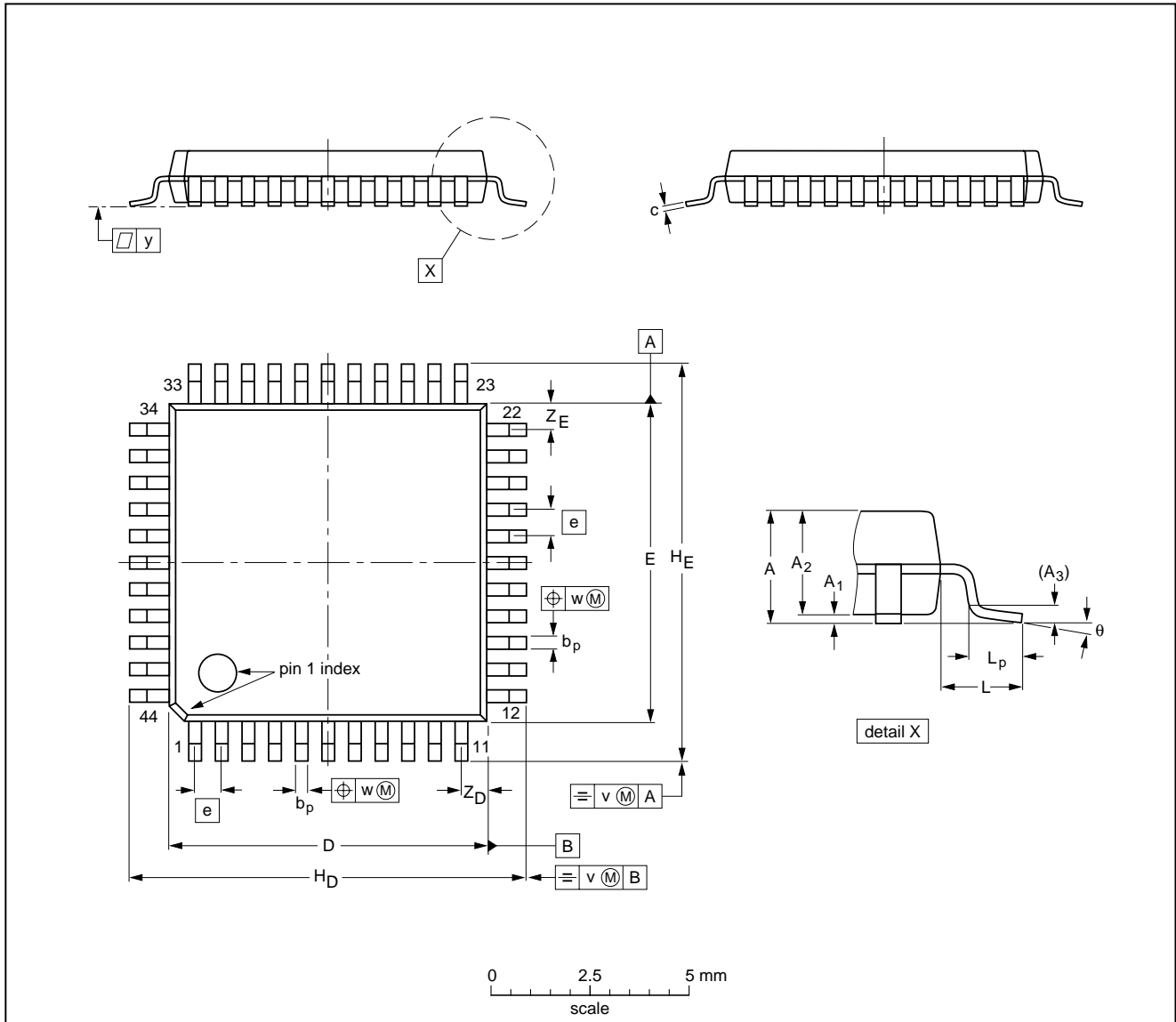

DIMENSIONS (mm are the original dimensions)

| UNIT | A max. | A ₁ | A ₂ | A ₃ | b _p | c | D ⁽¹⁾ | E ⁽¹⁾ | e | H _D | H _E | L | L _p | v | w | y | Z _D ⁽¹⁾ | Z _E ⁽¹⁾ | θ |
|------|--------|----------------|----------------|----------------|----------------|--------------|------------------|------------------|-----|----------------|----------------|-----|----------------|------|------|-----|-------------------------------|-------------------------------|-----------|
| mm | 2.10 | 0.25 0.05 | 1.85 1.65 | 0.25 | 0.40 0.20 | 0.25 0.14 | 10.1 9.9 | 10.1 9.9 | 0.8 | 12.9 12.3 | 12.9 12.3 | 1.3 | 0.95 0.55 | 0.15 | 0.15 | 0.1 | 1.2 0.8 | 1.2 0.8 | 10° 0° |

Note

1. Plastic or metal protrusions of 0.25 mm maximum per side are not included.

| OUTLINE VERSION | REFERENCES | | | | EUROPEAN PROJECTION | ISSUE DATE |
|-----------------|------------|-------|------|--|---------------------|----------------------|
| | IEC | JEDEC | EIAJ | | | |
| SOT307-2 | | | | | | 95-02-04 97-08-01 |

Self Tuned Radio (STR)

TEA5757; TEA5759

SOLDERING

Introduction

There is no soldering method that is ideal for all IC packages. Wave soldering is often preferred when through-hole and surface mounted components are mixed on one printed-circuit board. However, wave soldering is not always suitable for surface mounted ICs, or for printed-circuits with high population densities. In these situations reflow soldering is often used.

This text gives a very brief insight to a complex technology. A more in-depth account of soldering ICs can be found in our *"IC Package Databook"* (order code 9398 652 90011).

Reflow soldering

Reflow soldering techniques are suitable for all QFP packages.

The choice of heating method may be influenced by larger plastic QFP packages (44 leads, or more). If infrared or vapour phase heating is used and the large packages are not absolutely dry (less than 0.1% moisture content by weight), vaporization of the small amount of moisture in them can cause cracking of the plastic body. For more information, refer to the Drypack chapter in our *"Quality Reference Handbook"* (order code 9397 750 00192).

Reflow soldering requires solder paste (a suspension of fine solder particles, flux and binding agent) to be applied to the printed-circuit board by screen printing, stencilling or pressure-syringe dispensing before package placement.

Several techniques exist for reflowing; for example, thermal conduction by heated belt. Dwell times vary between 50 and 300 seconds depending on heating method. Typical reflow temperatures range from 215 to 250 °C.

Preheating is necessary to dry the paste and evaporate the binding agent. Preheating duration: 45 minutes at 45 °C.

Wave soldering

Wave soldering is **not** recommended for QFP packages. This is because of the likelihood of solder bridging due to closely-spaced leads and the possibility of incomplete solder penetration in multi-lead devices.

If wave soldering cannot be avoided, the following conditions must be observed:

- **A double-wave (a turbulent wave with high upward pressure followed by a smooth laminar wave) soldering technique should be used.**
- **The footprint must be at an angle of 45° to the board direction and must incorporate solder thieves downstream and at the side corners.**

Even with these conditions, do not consider wave soldering the following packages: QFP52 (SOT379-1), QFP100 (SOT317-1), QFP100 (SOT317-2), QFP100 (SOT382-1) or QFP160 (SOT322-1).

During placement and before soldering, the package must be fixed with a droplet of adhesive. The adhesive can be applied by screen printing, pin transfer or syringe dispensing. The package can be soldered after the adhesive is cured.

Maximum permissible solder temperature is 260 °C, and maximum duration of package immersion in solder is 10 seconds, if cooled to less than 150 °C within 6 seconds. Typical dwell time is 4 seconds at 250 °C.

A mildly-activated flux will eliminate the need for removal of corrosive residues in most applications.

Repairing soldered joints

Fix the component by first soldering two diagonally-opposite end leads. Use only a low voltage soldering iron (less than 24 V) applied to the flat part of the lead. Contact time must be limited to 10 seconds at up to 300 °C. When using a dedicated tool, all other leads can be soldered in one operation within 2 to 5 seconds between 270 and 320 °C.

Self Tuned Radio (STR)

TEA5757; TEA5759

DEFINITIONS

| | |
|---|---|
| Data sheet status | |
| Objective specification | This data sheet contains target or goal specifications for product development. |
| Preliminary specification | This data sheet contains preliminary data; supplementary data may be published later. |
| Product specification | This data sheet contains final product specifications. |
| Limiting values | |
| Limiting values given are in accordance with the Absolute Maximum Rating System (IEC 134). Stress above one or more of the limiting values may cause permanent damage to the device. These are stress ratings only and operation of the device at these or at any other conditions above those given in the Characteristics sections of the specification is not implied. Exposure to limiting values for extended periods may affect device reliability. | |
| Application information | |
| Where application information is given, it is advisory and does not form part of the specification. | |

LIFE SUPPORT APPLICATIONS

These products are not designed for use in life support appliances, devices, or systems where malfunction of these products can reasonably be expected to result in personal injury. Philips customers using or selling these products for use in such applications do so at their own risk and agree to fully indemnify Philips for any damages resulting from such improper use or sale.

Philips Semiconductors – a worldwide company

Argentina: IEROD, Av. Juramento 1992 - 14.b, (1428)
BUENOS AIRES, Tel. (541)786 7633, Fax. (541)786 9367

Australia: 34 Waterloo Road, NORTH RYDE, NSW 2113,
Tel. (02)805 4455, Fax. (02)805 4466

Austria: Triester Str. 64, A-1101 WIEN, P.O. Box 213,
Tel. (01)60 101-1236, Fax. (01)60 101-1211

Belgium: Postbus 90050, 5600 PB EINDHOVEN, The Netherlands,
Tel. (31)40-2783749, Fax. (31)40-2788399

Brazil: Rua do Rocio 220 - 5th floor, Suite 51,
CEP: 04552-903-SÃO PAULO-SP, Brazil,
P.O. Box 7383 (01064-970),
Tel. (011)821-2333, Fax. (011)829-1849

Canada: PHILIPS SEMICONDUCTORS/COMPONENTS:
Tel. (800) 234-7381, Fax. (708) 296-8556

Chile: Av. Santa Maria 0760, SANTIAGO,
Tel. (02)773 816, Fax. (02)777 6730

China/Hong Kong: 501 Hong Kong Industrial Technology Centre,
72 Tat Chee Avenue, Kowloon Tong, HONG KONG,
Tel. (852)2319 7888, Fax. (852)2319 7700

Colombia: IPRELENZO LTDA, Carrera 21 No. 56-17,
77621 BOGOTA, Tel. (571)249 7624/(571)217 4609,
Fax. (571)217 4549

Denmark: Prags Boulevard 80, PB 1919, DK-2300
COPENHAGEN S, Tel. (45)32 88 26 36, Fax. (45)31 57 19 49

Finland: Sinikalliontie 3, FIN-02630 ESPOO,
Tel. (358)0-615 800, Fax. (358)0-61580 920

France: 4 Rue du Port-aux-Vins, BP317,
92156 SURESNES Cedex,
Tel. (01)4099 6161, Fax. (01)4099 6427

Germany: P.O. Box 10 51 40, 20035 HAMBURG,
Tel. (040)23 53 60, Fax. (040)23 53 63 00

Greece: No. 15, 25th March Street, GR 17778 TAVROS,
Tel. (01)4894 339/4894 911, Fax. (01)4814 240

India: Philips INDIA Ltd, Shivsagar Estate, A Block,
Dr. Annie Besant Rd. Worli, Bombay 400 018
Tel. (022)4938 541, Fax. (022)4938 722

Indonesia: Philips House, Jalan H.R. Rasuna Said Kav. 3-4,
P.O. Box 4252, JAKARTA 12950,
Tel. (021)5201 122, Fax. (021)5205 189

Ireland: Newstead, Clonskeagh, DUBLIN 14,
Tel. (01)7640 000, Fax. (01)7640 200

Italy: PHILIPS SEMICONDUCTORS S.r.l.,
Piazza IV Novembre 3, 20124 MILANO,
Tel. (0039)2 6752 2531, Fax. (0039)2 6752 2557

Japan: Philips Bldg 13-37, Kohnan2-chome, Minato-ku, TOKYO 108,
Tel. (03)3740 5130, Fax. (03)3740 5077

Korea: Philips House, 260-199 Itaewon-dong,
Yongsan-ku, SEOUL, Tel. (02)709-1412, Fax. (02)709-1415

Malaysia: No. 76 Jalan Universiti, 46200 PETALING JAYA,
SELANGOR, Tel. (03)750 5214, Fax. (03)757 4880

Mexico: 5900 Gateway East, Suite 200, EL PASO, TX 79905,
Tel. 9-5(800)234-7381, Fax. (708)296-8556

Netherlands: Postbus 90050, 5600 PB EINDHOVEN, Bldg. VB,
Tel. (040)2783749, Fax. (040)2788399

New Zealand: 2 Wagener Place, C.P.O. Box 1041, AUCKLAND,
Tel. (09)849-4160, Fax. (09)849-7811

Norway: Box 1, Manglerud 0612, OSLO,
Tel. (022)74 8000, Fax. (022)74 8341

Pakistan: Philips Electrical Industries of Pakistan Ltd.,
Exchange Bldg. ST-2/A, Block 9, KDA Scheme 5, Clifton,
KARACHI 75600, Tel. (021)587 4641-49,
Fax. (021)577035/5874546

Philippines: PHILIPS SEMICONDUCTORS PHILIPPINES Inc.,
106 Valero St. Salcedo Village, P.O. Box 2108 MCC, MAKATI,
Metro MANILA, Tel. (63) 2 816 6380, Fax. (63) 2 817 3474

Portugal: PHILIPS PORTUGUESA, S.A.,
Rua dr. António Loureiro Borges 5, Arquiparque - Miraflores,
Apartado 300, 2795 LINDA-A-VELHA,
Tel. (01)4163160/4163333, Fax. (01)4163174/4163366

Singapore: Lorong 1, Toa Payoh, SINGAPORE 1231,
Tel. (65)350 2000, Fax. (65)251 6500

South Africa: S.A. PHILIPS Pty Ltd.,
195-215 Main Road Martindale, 2092 JOHANNESBURG,
P.O. Box 7430, Johannesburg 2000,
Tel. (011)470-5911, Fax. (011)470-5494

Spain: Balmes 22, 08007 BARCELONA,
Tel. (03)301 6312, Fax. (03)301 42 43

Sweden: Kottbygatan 7, Akalla. S-164 85 STOCKHOLM,
Tel. (0)8-632 2000, Fax. (0)8-632 2745

Switzerland: Allmendstrasse 140, CH-8027 ZÜRICH,
Tel. (01)488 2211, Fax. (01)481 77 30

Taiwan: PHILIPS TAIWAN Ltd., 23-30F, 66, Chung Hsiao West
Road, Sec. 1. Taipeh, Taiwan ROC, P.O. Box 22978,
TAIPEI 100, Tel. (886) 2 382 4443, Fax. (886) 2 382 4444

Thailand: PHILIPS ELECTRONICS (THAILAND) Ltd.,
209/2 Sanpavuth-Bangna Road Prakanong,
Bangkok 10260, THAILAND,
Tel. (66) 2 745-4090, Fax. (66) 2 398-0793

Turkey: Talatpasa Cad. No. 5, 80640 GÜLTEPE/ISTANBUL,
Tel. (0212)279 27 70, Fax. (0212)282 67 07

Ukraine: Philips UKRAINE, 2A Akademika Koroleva str., Office 165,
252148 KIEV, Tel. 380-44-4760297, Fax. 380-44-4766991

United Kingdom: Philips Semiconductors LTD.,
276 Bath Road, Hayes, MIDDLESEX UB3 5BX,
Tel. (0181)730-5000, Fax. (0181)754-8421

United States: 811 East Arques Avenue, SUNNYVALE,
CA 94088-3409, Tel. (800)234-7381, Fax. (708)296-8556

Uruguay: Coronel Mora 433, MONTEVIDEO,
Tel. (02)70-4044, Fax. (02)92 0601

Internet: <http://www.semiconductors.philips.com/ps/>

For all other countries apply to: Philips Semiconductors,
International Marketing and Sales, Building BE-p,
P.O. Box 218, 5600 MD EINDHOVEN, The Netherlands,
Telex 35000 phtcnl, Fax. +31-40-2724825

SCDS47

© Philips Electronics N.V. 1996

All rights are reserved. Reproduction in whole or in part is prohibited without the prior written consent of the copyright owner.

The information presented in this document does not form part of any quotation or contract, is believed to be accurate and reliable and may be changed without notice. No liability will be accepted by the publisher for any consequence of its use. Publication thereof does not convey nor imply any license under patent- or other industrial or intellectual property rights.

Printed in The Netherlands

517021/1100/02/pp32
Document order number:

Date of release: 1996 Jan 09
9397 750 00557