

# DATA SHEET

## **TDA1387T** **Stereo Continuous Calibration DAC** **(CC-DAC)**

Preliminary specification  
Supersedes data of September 1994  
File under Integrated Circuits, IC01

1995 Dec 11

# Stereo Continuous Calibration DAC (CC-DAC)

# TDA1387T

## FEATURES

- Low power consumption
- Low total harmonic distortion
- Wide dynamic range (16-bit resolution)
- Continuous Calibration (CC) concept
- Single 3 to 5.5 V supply rail
- Output and bias current are proportional to the supply voltage
- Fast settling time enables 2, 4 and 8 times oversampling (serial input) or double-speed operation at 4 times oversampling
- Internal bias current ensures maximum dynamic range
- Wide operating temperature range (−40 to + 85 °C)
- I<sup>2</sup>S-bus input format (time multiplex, two's complement, TTL)
- No zero-crossing distortion
- Large DC output voltage compliance
- Contained in small outline package.

## APPLICATIONS

- Portable digital audio equipment.

## GENERAL DESCRIPTION

The TDA1387T is a member of a generation of digital-to-analog converters which incorporates the innovative technique of Continuous Calibration. The largest bit currents are repeatedly generated from one single reference current. This duplication is based upon an internal charge storage principle and has an accuracy which is insensitive to ageing, temperature and process variations.

The TDA1387T is fabricated in a 1.0 μm CMOS process and features an extremely low power dissipation, small package size and easy application. The intrinsic high coarse current accuracy combined with the implemented symmetrical offset decoding method preclude zero-crossing distortion and ensure high quality audio reproduction. The CC-DAC is eminently suitable for use in portable digital audio equipment.

## ORDERING INFORMATION

TYPE NUMBER	PACKAGE		
	NAME	DESCRIPTION	VERSION
TDA1387T	SO8	plastic small outline package; 8 leads; body width 3.9 mm.	SOT96-1

## Stereo Continuous Calibration DAC (CC-DAC)

TDA1387T

## QUICK REFERENCE DATA

SYMBOL	PARAMETER	CONDITIONS	MIN.	TYP.	MAX.	UNIT
$V_{DD}$	supply voltage		3.0	5.0	5.5	V
$I_{DD}$	supply current	$V_{DD} = 5\text{ V}$ at code 0000H	–	5.5	6.5	mA
$I_{FS}$	full scale output current	$V_{DD} = 5\text{ V}$	0.86	1.0	1.14	mA
		$V_{DD} = 3\text{ V}$	–	0.6	–	mA
(THD + N)/S	total harmonic distortion plus noise-to-signal ratio	at 0 dB signal level	–	–88	–78	dB
		at 0 dB signal level	–	0.004	0.012	%
		at –60 dB signal level	–	–33	–24	dB
		at –60 dB signal level	–	2.2	6	%
		at –60 dB; A-weighted	–	–35	–	dB
		at –60 dB; A-weighted	–	1.7	–	%
S/N	signal-to-noise ratio at bipolar zero	A-weighted at code 0000H	86	98	–	dB
$t_{cs}$	current settling time to $\pm 1$ LSB		–	0.2	–	$\mu\text{s}$
BR	input bit rate (pin 3)		–	–	18.4	Mbits/s
$f_{clk}$	clock frequency		–	–	18.4	MHz
$TC_{FS}$	full scale temperature coefficient at pins 6 and 8		–	$\pm 400 \times 10^{-6}$	–	
$T_{amb}$	operating ambient temperature		–40	–	+85	$^{\circ}\text{C}$
$P_{tot}$	total power dissipation	$V_{DD} = 5\text{ V}$ at code 0000H	–	27.5	36	mW
		$V_{DD} = 3\text{ V}$ at code 0000H	–	10	–	mW

# Stereo Continuous Calibration DAC (CC-DAC)

# TDA1387T

## BLOCK DIAGRAM

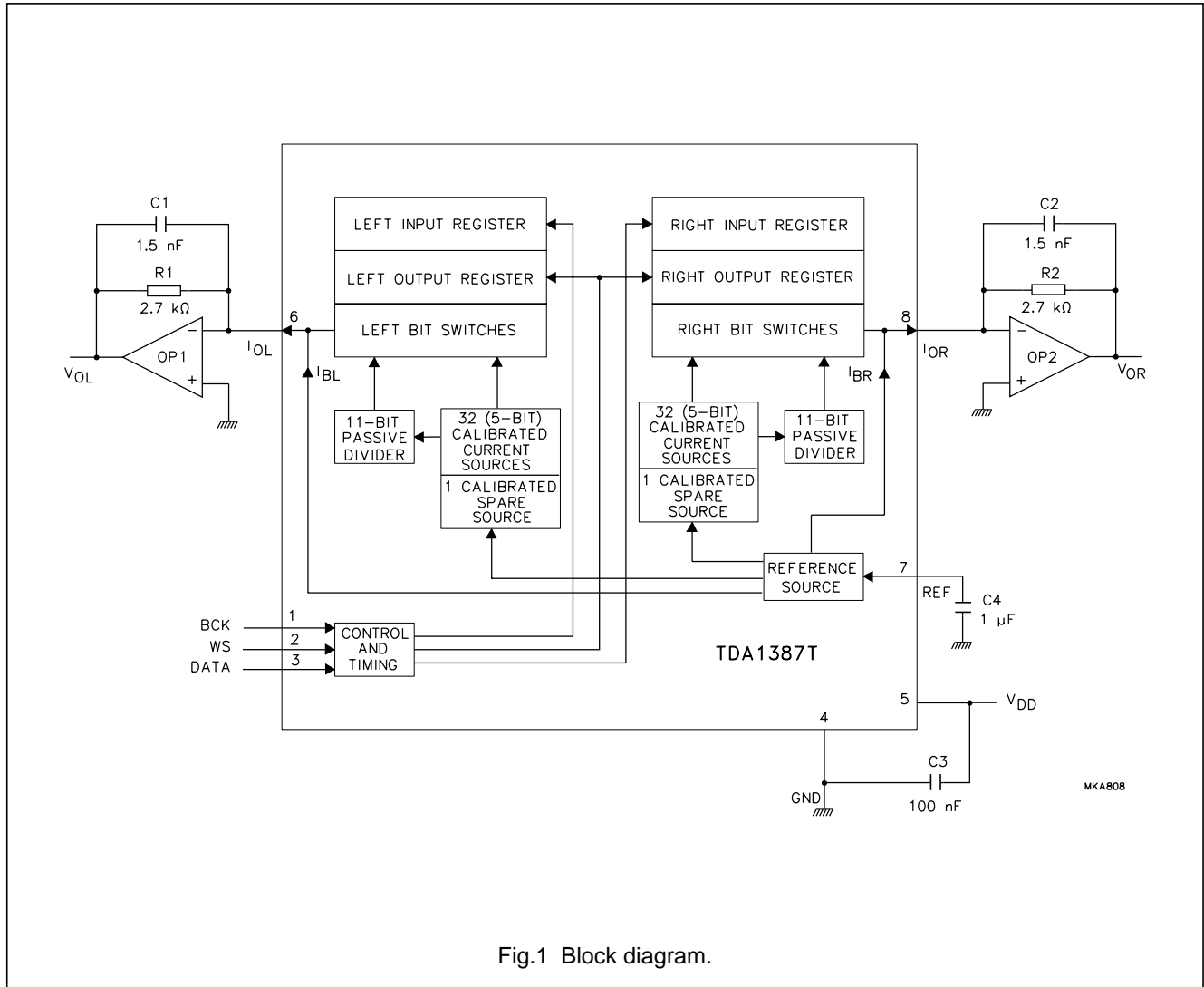

## Stereo Continuous Calibration DAC (CC-DAC)

## TDA1387T

## PINNING

SYMBOL	PIN	DESCRIPTION
BCK	1	bit clock input
WS	2	word selection input
DATA	3	data input
GND	4	ground
V <sub>DD</sub>	5	supply voltage input
I <sub>OL</sub>	6	left channel output
REF	7	reference decoupling
I <sub>OR</sub>	8	right channel output

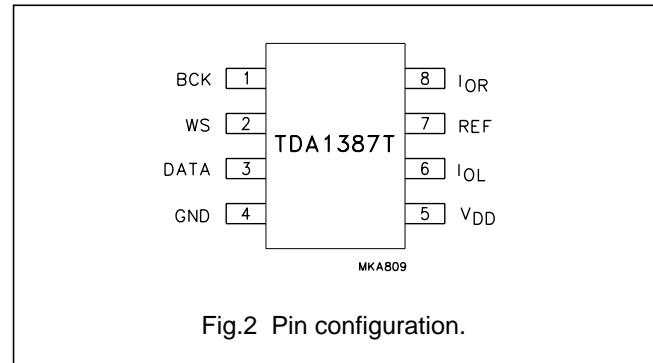

## FUNCTIONAL DESCRIPTION

The basic operation of the continuous calibration DAC is illustrated in Fig.3 which shows the calibration and operation cycle. During calibration of the MOS current source (Fig.3a) transistor M1 is connected as a diode by applying a reference current. The voltage  $V_{gs}$  on the intrinsic gate-source capacitance  $C_{gs}$  of M1 is then determined by the transistor characteristics. After the drain current has been calibrated to the reference value  $I_{ref}$ , the switch S1 is opened and S2 is switched to the other position (Fig.3b). The gate-to-source voltage  $V_{gs}$  of M1 is not changed because the charge on  $C_{gs}$  is preserved. Therefore, the drain current of M1 will still be equal to  $I_{ref}$  and this exact duplication of  $I_{ref}$  is now available at the OUT terminal.

In the TDA1387T, 32 current sources and one spare current source are continuously calibrated (see Fig.1). The spare current source is included to allow continuous converter operation. The output of one calibrated source is connected to an 11-bit binary current divider which consists of 2048 transistors. A symmetrical offset decoding principle is incorporated and arranges the bit switching such that the zero-crossing is performed by switching only the LSB currents.

The TDA1387T (CC-DAC) accepts serial input data format of 16-bit word length. Left and right data words are time multiplexed. The input data format is shown in Figs 4 and 5.

With a HIGH level on the WS input, data is placed in the right input register, with a LOW level on the WS input, data is placed in the left input register. The data in the input registers are simultaneously latched to the output registers which control the bit switches. An internal bias current  $I_{bias}$  is added to the full scale output current  $I_{FS}$  in order to achieve maximum dynamic range at the outputs of OP1 and OP2.

The signal current  $I_{FS}$  and the bias current  $I_{bias}$  are both proportional to the supply voltage  $V_{DD}$ , and have a fixed mutual relation  $A_{bias}$  (where  $A_{bias} = I_{bias}/I_{FS}$ ).

It is preferred that the non-inverting input of operational amplifiers OP1 and OP2 is tied to ground to achieve a maximum dynamic range over the supply voltage range.

A decoupling capacitor C4 is recommended for enhancing the supply voltage ripple rejection of the DAC. It has no significant effect on the noise performance.

Stereo Continuous Calibration DAC (CC-DAC)

TDA1387T

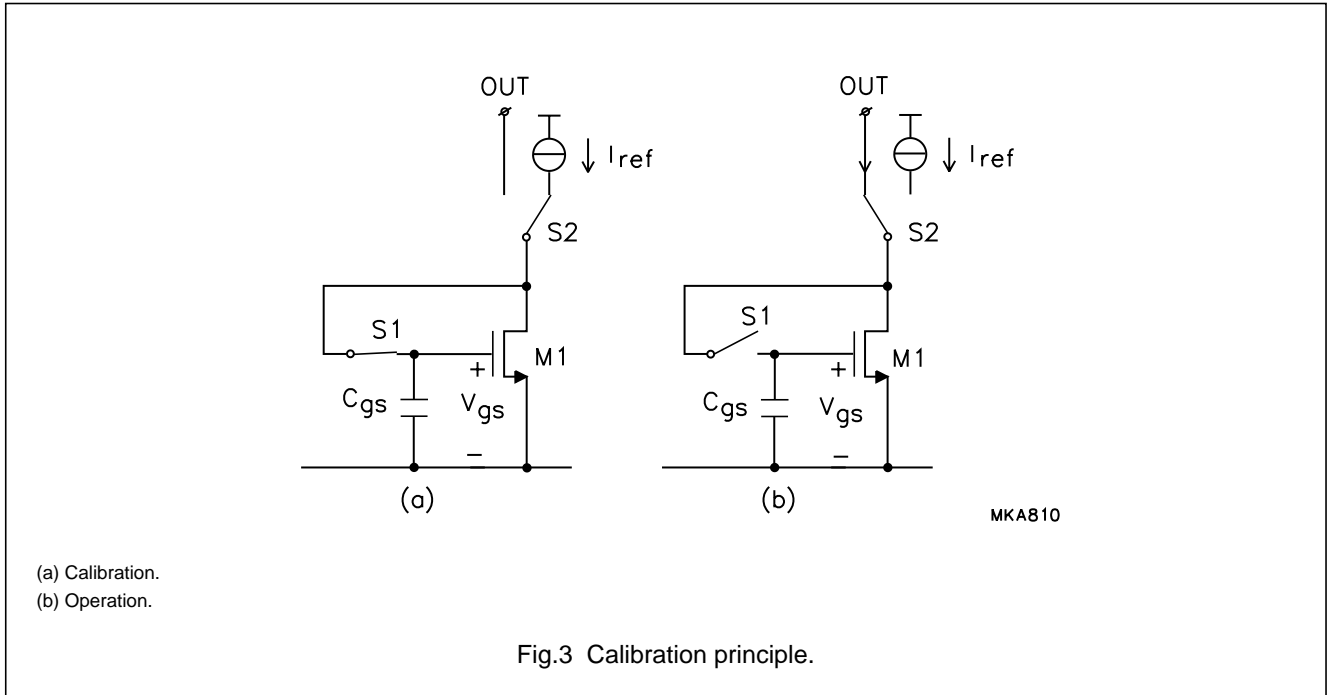

**LIMITING VALUES**

In accordance with the Absolute Maximum Rating System (IEC 134).

SYMBOL	DESCRIPTION	CONDITIONS	MIN.	MAX.	UNIT
$V_{DD}$	supply voltage		-	6.0	V
$T_{xtal(max)}$	maximum crystal temperature		-	+150	°C
$T_{stg}$	storage temperature		-55	+150	°C
$T_{amb}$	operating ambient temperature		-40	+85	°C
$V_{es}$	electrostatic handling	note 1	-2000	+2000	V
		note 2	-200	+200	V

**Notes**

- Human body model: C = 100 pF; R = 1.5 kΩ; 3 zaps positive and 3 zaps negative.
- Machine model: C = 200 pF; L = 0.5 μH; R = 10 Ω; 3 zaps positive and 3 zaps negative.

**THERMAL CHARACTERISTICS**

SYMBOL	DESCRIPTION	VALUE	UNIT
$R_{th j-a}$	thermal resistance from junction to ambient in free air	210	K/W

## Stereo Continuous Calibration DAC (CC-DAC)

TDA1387T

**CHARACTERISTICS** $V_{DD} = 5\text{ V}$ ;  $T_{amb} = 25\text{ }^{\circ}\text{C}$ ; unless otherwise specified.

SYMBOL	PARAMETER	CONDITIONS	MIN.	TYP.	MAX.	UNIT
<b>Supply</b>						
$V_{DD}$	supply voltage		3.0	5.0	5.5	V
$I_{DD}$	supply current	at code 0000H	–	5.5	6.5	mA
SVRR	supply voltage ripple rejection	note 1	–	30	–	dB
<b>Digital inputs; WS, BCK and DATA</b>						
$ I_{LI} $	LOW level input leakage current	$V_i = 0\text{ V}$	–	–	10	$\mu\text{A}$
$ I_{HI} $	HIGH level input leakage current	$V_i = 5\text{ V}$	–	–	10	$\mu\text{A}$
$f_{BCK}$	clock frequency		–	–	18.4	MHz
BR	data bit rate		–	–	18.4	Mbits/s
$f_{WS}$	word select input frequency		–	–	384	kHz
<b>Timing</b>						
$t_r$	rise time		–	–	12	ns
$t_f$	fall time		–	–	12	ns
$T_{cy}$	bit clock cycle time		54	–	–	ns
$t_{HB}$	bit clock HIGH time		15	–	–	ns
$t_{LB}$	bit clock LOW time		15	–	–	ns
$t_{su,DA}$	data set-up time		12	–	–	ns
$t_{h,DA}$	data hold time		2	–	–	ns
$t_{h,WS}$	word select hold time		2	–	–	ns
$t_{su,WS}$	word select set-up time		12	–	–	ns

## Stereo Continuous Calibration DAC (CC-DAC)

TDA1387T

SYMBOL	PARAMETER	CONDITIONS	MIN.	TYP.	MAX.	UNIT
<b>Analog outputs; I<sub>OL</sub> and I<sub>OR</sub></b>						
RES	output resolution		–	–	16	bits
V <sub>DCC</sub>	DC output voltage compliance		0	–	3.5	V
I <sub>o(p-p)</sub>	AC output signal current (peak-to-peak value)	note 2	0.86	1.0	1.14	mA
TC <sub>FS</sub>	full-scale temperature coefficient		–	±400 × 10 <sup>-6</sup>	–	
I <sub>bias</sub>	output bias current	note 2	0.93	1.08	1.23	mA
V <sub>ref</sub>	output reference voltage	note 2	–	1/6 V <sub>DD</sub>	–	V
R <sub>ref</sub>	output resistance at pin 7		7.6	11.4	14.8	kΩ
(TDH + N)/S	total harmonic distortion plus noise-to-signal ratio	at 0 dB signal level; note 3	–	–88	–78	dB
		at 0 dB signal level; note 3	–	0.004	0.01	%
		at –60 dB signal level; note 3	–	–33	–24	dB
		at –60 dB signal level; note 3	–	2.2	6	%
		at –60 dB; A-weighted; note 3	–	–35	–	dB
		at –60 dB; A-weighted; note 3	–	1.8	–	%
		f <sub>i</sub> = 20 Hz to 20 kHz; at 0 dB signal level; note 3	–	–84	–70	dB
		f <sub>i</sub> = 20 Hz to 20 kHz; at 0 dB signal level; note 3	–	0.006	0.03	%
t <sub>cs</sub>	current settling time to ±1 LSB		–	0.2	–	μs
α <sub>CS</sub>	channel separation		86	95	–	dB
Δ <sub>O</sub>	unbalance between outputs	note 3	–	0.2	0.3	dB
t <sub>d</sub>	delay time between outputs		–	±0.2	–	μs
S/N	signal-to-noise ratio at bipolar zero	A-weighted at code 0000H	86	98	–	dB

**Notes**

1. V<sub>ripple</sub> = 1% of the supply voltage; f<sub>ripple</sub> = 100 Hz.
2. Values are proportional to V<sub>DD</sub>.
3. Measured with 1 kHz sine wave generated at a sampling rate of 192 kHz.

**QUALITY SPECIFICATION**

In accordance with “SNW-FQ-611E”. The numbers of the quality specification can be found in the “Quality Reference Handbook”. The handbook can be ordered using the code 9397 750 00192.



Stereo Continuous Calibration DAC (CC-DAC)

TDA1387T

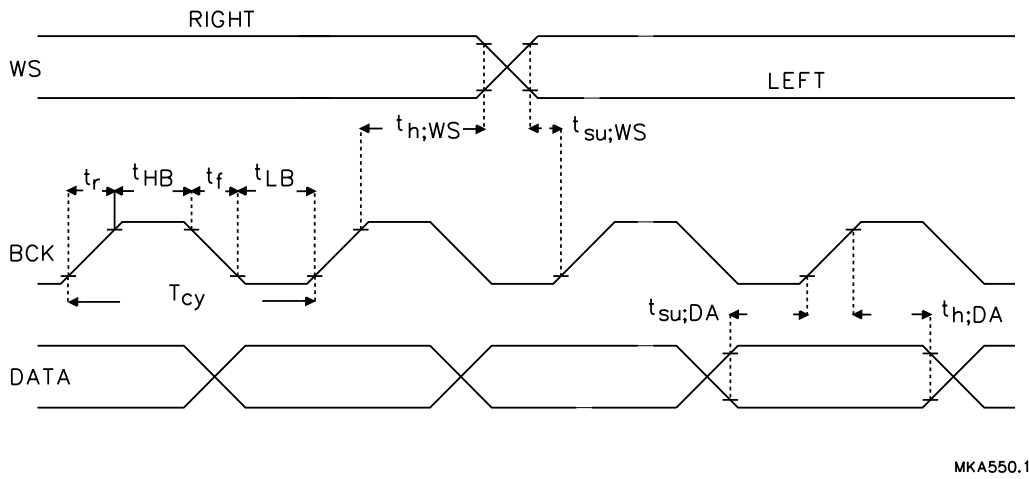

MKA550.1

Fig.4 Input signal timing (I²S-bus).

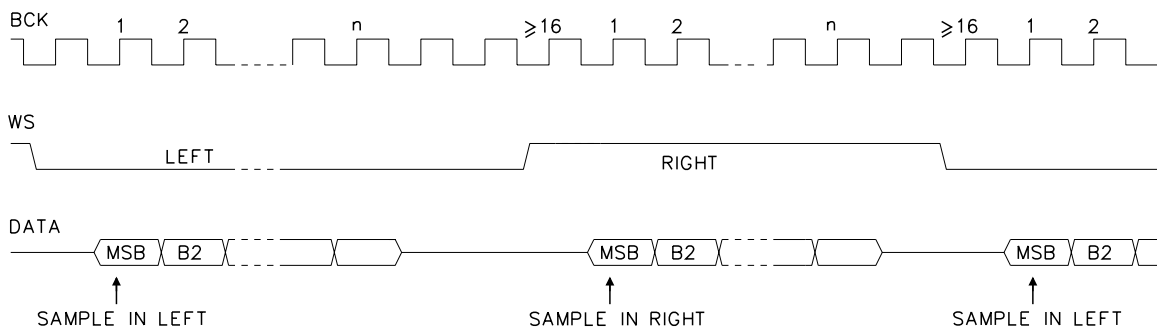

MKA811

Fig.5 Input signal format (I²S-bus).

---

## Stereo Continuous Calibration DAC (CC-DAC)

TDA1387T

---

### APPLICATION INFORMATION

The TDA1387T offers great ease in designing-in to printed-circuit board due to its small size and low pin count. The TDA1387T being a mixed-signal IC in CMOS, some attention needs to be paid to layout and topology of the application PCB. The following basic rules will yield the desired performance. The most important considerations are:

1. Supply: care should be taken to supply the TDA1387T with a clean, noiseless supply voltage, for a good noise performance of the analog parts of the DAC. Supply purity can easily be achieved by using an RC-filtered supply.
2. Grounding: preferably a ground plane should be used, in order to have a low-impedance return available at any point in the layout. It is advantageous to make a partitioning of the ground plane according to the nature of the expected return currents (digital input returns separate from supply returns separate from the analog section).
3. Topology: the capacitor decoupling high-frequency supply interference from  $V_{DD}$  to GND should be placed as close as is physically possible to the IC body, ensuring a low-inductance path to ground. The digital input conductors may be shielded by ground leads running alongside. The placement of a passive ground plane underside the entire IC surface gives 'free' additional decoupling from the IC body to ground as well as providing a shield between the digital input pins and the analog output pins.

Stereo Continuous Calibration DAC (CC-DAC)

TDA1387T

PACKAGE OUTLINE

SO8: plastic small outline package; 8 leads (straight); body width 3.9 mm

SOT96-2

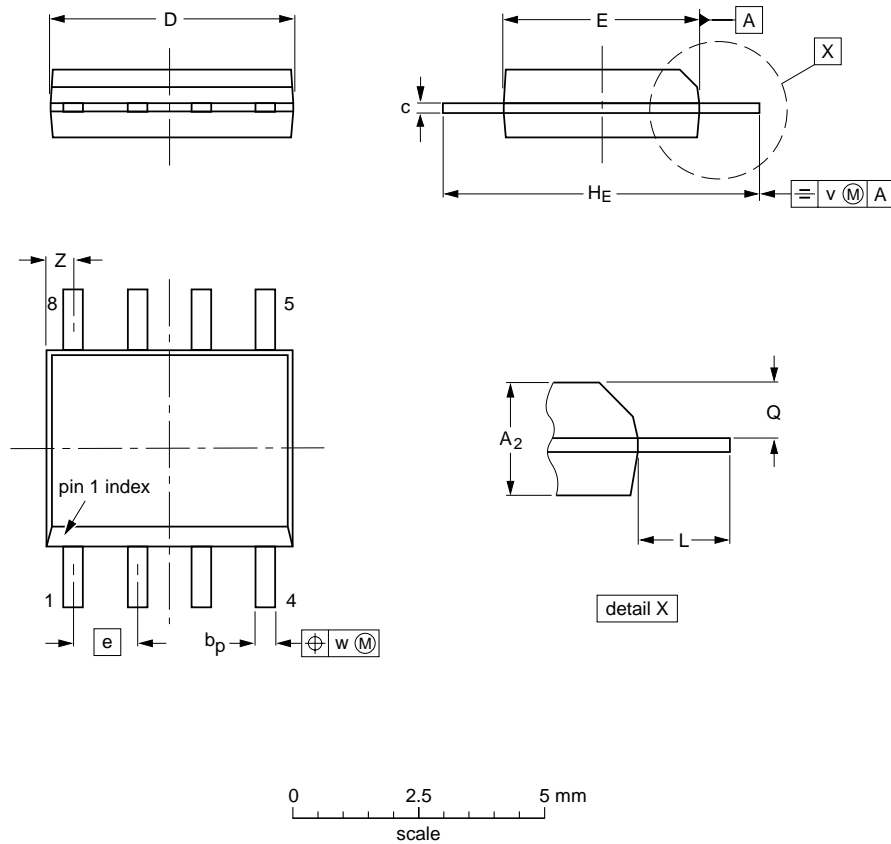

DIMENSIONS (inch dimensions are derived from the original mm dimensions)

UNIT	$A_2$	$b_p$	$c$	$D^{(1)}$	$E^{(2)}$	$e$	$H_E$	$L$	$Q$	$v$	$w$	$Z^{(1)}$
mm	1.45 1.25	0.49 0.36	0.25 0.19	5.0 4.8	4.0 3.8	1.27	6.4 6.2	1.2	0.7 0.6	0.25	0.25	0.7 0.3
inches	0.057 0.049	0.019 0.014	0.0100 0.0075	0.20 0.19	0.16 0.15	0.050	0.252 0.244	0.047	0.028 0.024	0.01	0.01	0.028 0.012

Notes

1. Plastic or metal protrusions of 0.15 mm maximum per side are not included.
2. Plastic or metal protrusions of 0.25 mm maximum per side are not included.

OUTLINE VERSION	REFERENCES				EUROPEAN PROJECTION	ISSUE DATE
	IEC	JEDEC	EIAJ			
SOT96-2						95-02-04 97-05-22

---

## Stereo Continuous Calibration DAC (CC-DAC)

TDA1387T

---

### SOLDERING

#### Introduction

There is no soldering method that is ideal for all IC packages. Wave soldering is often preferred when through-hole and surface mounted components are mixed on one printed-circuit board. However, wave soldering is not always suitable for surface mounted ICs, or for printed-circuits with high population densities. In these situations reflow soldering is often used.

This text gives a very brief insight to a complex technology. A more in-depth account of soldering ICs can be found in our *"IC Package Databook"* (order code 9398 652 90011).

#### Reflow soldering

Reflow soldering techniques are suitable for all SO packages.

Reflow soldering requires solder paste (a suspension of fine solder particles, flux and binding agent) to be applied to the printed-circuit board by screen printing, stencilling or pressure-syringe dispensing before package placement.

Several techniques exist for reflowing; for example, thermal conduction by heated belt. Dwell times vary between 50 and 300 seconds depending on heating method. Typical reflow temperatures range from 215 to 250 °C.

Preheating is necessary to dry the paste and evaporate the binding agent. Preheating duration: 45 minutes at 45 °C.

#### Wave soldering

Wave soldering techniques can be used for all SO packages if the following conditions are observed:

- A double-wave (a turbulent wave with high upward pressure followed by a smooth laminar wave) soldering technique should be used.
- The longitudinal axis of the package footprint must be parallel to the solder flow.
- The package footprint must incorporate solder thieves at the downstream end.

During placement and before soldering, the package must be fixed with a droplet of adhesive. The adhesive can be applied by screen printing, pin transfer or syringe dispensing. The package can be soldered after the adhesive is cured.

Maximum permissible solder temperature is 260 °C, and maximum duration of package immersion in solder is 10 seconds, if cooled to less than 150 °C within 6 seconds. Typical dwell time is 4 seconds at 250 °C.

A mildly-activated flux will eliminate the need for removal of corrosive residues in most applications.

#### Repairing soldered joints

Fix the component by first soldering two diagonally-opposite end leads. Use only a low voltage soldering iron (less than 24 V) applied to the flat part of the lead. Contact time must be limited to 10 seconds at up to 300 °C. When using a dedicated tool, all other leads can be soldered in one operation within 2 to 5 seconds between 270 and 320 °C.

## Stereo Continuous Calibration DAC (CC-DAC)

TDA1387T

**DEFINITIONS**

<b>Data sheet status</b>	
Objective specification	This data sheet contains target or goal specifications for product development.
Preliminary specification	This data sheet contains preliminary data; supplementary data may be published later.
Product specification	This data sheet contains final product specifications.
<b>Limiting values</b>	
Limiting values given are in accordance with the Absolute Maximum Rating System (IEC 134). Stress above one or more of the limiting values may cause permanent damage to the device. These are stress ratings only and operation of the device at these or at any other conditions above those given in the Characteristics sections of the specification is not implied. Exposure to limiting values for extended periods may affect device reliability.	
<b>Application information</b>	
Where application information is given, it is advisory and does not form part of the specification.	

**LIFE SUPPORT APPLICATIONS**

These products are not designed for use in life support appliances, devices, or systems where malfunction of these products can reasonably be expected to result in personal injury. Philips customers using or selling these products for use in such applications do so at their own risk and agree to fully indemnify Philips for any damages resulting from such improper use or sale.

---

Stereo Continuous Calibration DAC  
(CC-DAC)

---

TDA1387T

NOTES

---

Stereo Continuous Calibration DAC  
(CC-DAC)

TDA1387T

---

NOTES

## Philips Semiconductors – a worldwide company

**Argentina:** IEROD, Av. Juramento 1992 - 14.b, (1428)  
BUENOS AIRES, Tel. (541)786 7633, Fax. (541)786 9367

**Australia:** 34 Waterloo Road, NORTH RYDE, NSW 2113,  
Tel. (02)805 4455, Fax. (02)805 4466

**Austria:** Triester Str. 64, A-1101 WIEN, P.O. Box 213,  
Tel. (01)60 101-1236, Fax. (01)60 101-1211

**Belgium:** Postbus 90050, 5600 PB EINDHOVEN, The Netherlands,  
Tel. (31)40-2783749, Fax. (31)40-2788399

**Brazil:** Rua do Rocio 220 - 5<sup>th</sup> floor, Suite 51,  
CEP: 04552-903-SÃO PAULO-SP, Brazil,  
P.O. Box 7383 (01064-970),  
Tel. (011)821-2333, Fax. (011)829-1849

**Canada:** PHILIPS SEMICONDUCTORS/COMPONENTS:  
Tel. (800) 234-7381, Fax. (708) 296-8556

**Chile:** Av. Santa Maria 0760, SANTIAGO,  
Tel. (02)773 816, Fax. (02)777 6730

**China/Hong Kong:** 501 Hong Kong Industrial Technology Centre,  
72 Tat Chee Avenue, Kowloon Tong, HONG KONG,  
Tel. (852)2319 7888, Fax. (852)2319 7700

**Colombia:** IPRELENZO LTDA, Carrera 21 No. 56-17,  
77621 BOGOTA, Tel. (571)249 7624/(571)217 4609,  
Fax. (571)217 4549

**Denmark:** Prags Boulevard 80, PB 1919, DK-2300  
COPENHAGEN S, Tel. (45)32 88 26 36, Fax. (45)31 57 19 49

**Finland:** Sinikalliontie 3, FIN-02630 ESPOO,  
Tel. (358)0-615 800, Fax. (358)0-61580 920

**France:** 4 Rue du Port-aux-Vins, BP317,  
92156 SURESNES Cedex,  
Tel. (01)4099 6161, Fax. (01)4099 6427

**Germany:** P.O. Box 10 51 40, 20035 HAMBURG,  
Tel. (040)23 53 60, Fax. (040)23 53 63 00

**Greece:** No. 15, 25th March Street, GR 17778 TAVROS,  
Tel. (01)4894 339/4894 911, Fax. (01)4814 240

**India:** Philips INDIA Ltd, Shivsagar Estate, A Block,  
Dr. Annie Besant Rd. Worli, Bombay 400 018  
Tel. (022)4938 541, Fax. (022)4938 722

**Indonesia:** Philips House, Jalan H.R. Rasuna Said Kav. 3-4,  
P.O. Box 4252, JAKARTA 12950,  
Tel. (021)5201 122, Fax. (021)5205 189

**Ireland:** Newstead, Clonskeagh, DUBLIN 14,  
Tel. (01)7640 000, Fax. (01)7640 200

**Italy:** PHILIPS SEMICONDUCTORS S.r.l.,  
Piazza IV Novembre 3, 20124 MILANO,  
Tel. (0039)2 6752 2531, Fax. (0039)2 6752 2557

**Japan:** Philips Bldg 13-37, Kohnan2-chome, Minato-ku, TOKYO 108,  
Tel. (03)3740 5130, Fax. (03)3740 5077

**Korea:** Philips House, 260-199 Itaewon-dong,  
Yongsan-ku, SEOUL, Tel. (02)709-1412, Fax. (02)709-1415

**Malaysia:** No. 76 Jalan Universiti, 46200 PETALING JAYA,  
SELANGOR, Tel. (03)750 5214, Fax. (03)757 4880

**Mexico:** 5900 Gateway East, Suite 200, EL PASO, TX 79905,  
Tel. 9-5(800)234-7381, Fax. (708)296-8556

**Netherlands:** Postbus 90050, 5600 PB EINDHOVEN, Bldg. VB,  
Tel. (040)2783749, Fax. (040)2788399

**New Zealand:** 2 Wagener Place, C.P.O. Box 1041, AUCKLAND,  
Tel. (09)849-4160, Fax. (09)849-7811

**Norway:** Box 1, Manglerud 0612, OSLO,  
Tel. (022)74 8000, Fax. (022)74 8341

**Pakistan:** Philips Electrical Industries of Pakistan Ltd.,  
Exchange Bldg. ST-2/A, Block 9, KDA Scheme 5, Clifton,  
KARACHI 75600, Tel. (021)587 4641-49,  
Fax. (021)577035/5874546

**Philippines:** PHILIPS SEMICONDUCTORS PHILIPPINES Inc.,  
106 Valero St. Salcedo Village, P.O. Box 2108 MCC, MAKATI,  
Metro MANILA, Tel. (63) 2 816 6380, Fax. (63) 2 817 3474

**Portugal:** PHILIPS PORTUGUESA, S.A.,  
Rua dr. António Loureiro Borges 5, Arquiparque - Miraflores,  
Apartado 300, 2795 LINDA-A-VELHA,  
Tel. (01)4163160/4163333, Fax. (01)4163174/4163366

**Singapore:** Lorong 1, Toa Payoh, SINGAPORE 1231,  
Tel. (65)350 2000, Fax. (65)251 6500

**South Africa:** S.A. PHILIPS Pty Ltd.,  
195-215 Main Road Martindale, 2092 JOHANNESBURG,  
P.O. Box 7430, Johannesburg 2000,  
Tel. (011)470-5911, Fax. (011)470-5494

**Spain:** Balmes 22, 08007 BARCELONA,  
Tel. (03)301 6312, Fax. (03)301 42 43

**Sweden:** Kottbygatan 7, Akalla. S-164 85 STOCKHOLM,  
Tel. (0)8-632 2000, Fax. (0)8-632 2745

**Switzerland:** Allmendstrasse 140, CH-8027 ZÜRICH,  
Tel. (01)488 2211, Fax. (01)481 77 30

**Taiwan:** PHILIPS TAIWAN Ltd., 23-30F, 66, Chung Hsiao West  
Road, Sec. 1. Taipeh, Taiwan ROC, P.O. Box 22978,  
TAIPEI 100, Tel. (886) 2 382 4443, Fax. (886) 2 382 4444

**Thailand:** PHILIPS ELECTRONICS (THAILAND) Ltd.,  
209/2 Sanpavuth-Bangna Road Prakanong,  
Bangkok 10260, THAILAND,  
Tel. (66) 2 745-4090, Fax. (66) 2 398-0793

**Turkey:** Talatpasa Cad. No. 5, 80640 GÜLTEPE/ISTANBUL,  
Tel. (0212)279 27 70, Fax. (0212)282 67 07

**Ukraine:** Philips UKRAINE, 2A Akademika Koroleva str., Office 165,  
252148 KIEV, Tel. 380-44-4760297, Fax. 380-44-4766991

**United Kingdom:** Philips Semiconductors LTD.,  
276 Bath Road, Hayes, MIDDLESEX UB3 5BX,  
Tel. (0181)730-5000, Fax. (0181)754-8421

**United States:** 811 East Arques Avenue, SUNNYVALE,  
CA 94088-3409, Tel. (800)234-7381, Fax. (708)296-8556

**Uruguay:** Coronel Mora 433, MONTEVIDEO,  
Tel. (02)70-4044, Fax. (02)92 0601

**Internet:** <http://www.semiconductors.philips.com/ps/>

**For all other countries apply to:** Philips Semiconductors,  
International Marketing and Sales, Building BE-p,  
P.O. Box 218, 5600 MD EINDHOVEN, The Netherlands,  
Telex 35000 phtcnl, Fax. +31-40-2724825

SCD47

© Philips Electronics N.V. 1995

All rights are reserved. Reproduction in whole or in part is prohibited without the prior written consent of the copyright owner.

The information presented in this document does not form part of any quotation or contract, is believed to be accurate and reliable and may be changed without notice. No liability will be accepted by the publisher for any consequence of its use. Publication thereof does not convey nor imply any license under patent- or other industrial or intellectual property rights.

Printed in The Netherlands

513061/50/02/pp16

Document order number:

Date of release: 1995 Dec 11

9397 750 00519