



STTA5012TV1/2

TURBOSWITCH™ "A". ULTRA-FAST HIGH VOLTAGE DIODE

MAIN PRODUCTS CHARACTERISTICS

$I_{F(AV)}$	25A
V_{RRM}	1200V
t_{rr} (typ)	60ns
V_F (max)	1.9V

FEATURES AND BENEFITS

- ULTRA-FAST, SOFT AND NOISE-FREE RECOVERY.
- VERY LOW OVERALL POWER LOSSES IN BOTH THE DIODE AND THE COMPANION TRANSISTOR.
- HIGH FREQUENCY AND/OR HIGH PULSED CURRENT OPERATIONS.

DESCRIPTION

TURBOSWITCH 1200V drastically cuts losses in all high voltage operations which require extremely fast, soft and noise-free power diodes. Due to their optimized switching performances they also highly decrease power losses in any associated switching IGBT or MOSFET in all "Freewheel Mode" operations.

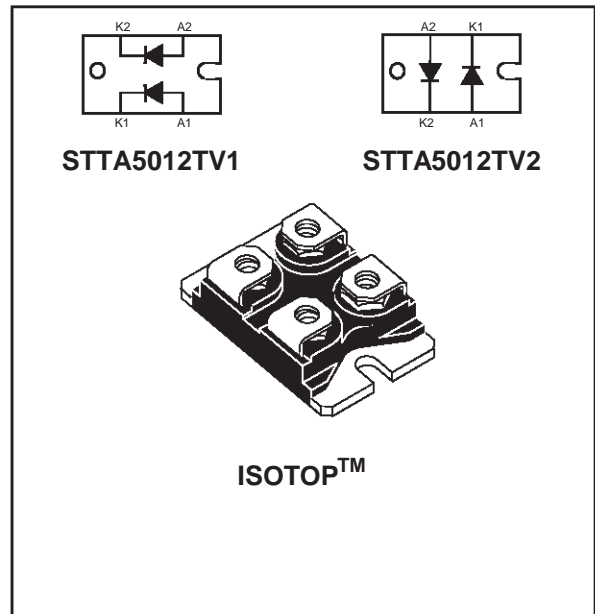

They are particularly suitable in Motor Control circuitries, or in the primary of SMPS as snubber, clamping or demagnetizing diodes, and also at the secondary of SMPS as high voltage rectifier diodes.

ABSOLUTE MAXIMUM RATINGS

Symbol	Parameter	Value	Unit
V_{RRM}	Repetitive peak reverse voltage	1200	V
V_{RSM}	Non repetitive peak reverse voltage	1200	V
$I_{F(RMS)}$	RMS forward current	50	A
I_{FRM}	Repetitive peak forward current ($t_p = 5 \mu s$, $F = 5 kHz$)	300	A
T_j	Maximum operating junction temperature	150	°C
T_{stg}	Storage temperature	-65 to 150	°C

ISOTOP and TURBOSWITCH are trademarks of STMicroelectronics.

STTA5012TV1/2

THERMAL AND POWER DATA

Symbol	Parameter	Conditions	Value	Unit
$R_{th(j-c)}$	Junction to case thermal resistance	Per diode	1.4	°C/W
		Total	0.75	
		Coupling	0.1	
P_1	Conduction power dissipation (see fig. 6)	$I_{F(AV)} = 25A$ $\delta = 0.5$ Per diode $T_c = 70^\circ C$	57	W
P_{max}	Total power dissipation $P_{max} = P_1 + P_3$ ($P_3 = 10\% P_1$)	Per diode $T_c = 62^\circ C$	62.5	W

STATIC ELECTRICAL CHARACTERISTICS (see Fig. 6)

Symbol	Parameter	Test Conditions	Min	Typ	Max	Unit
V_F *	Forward voltage drop	$I_F = 25A$ $T_j = 25^\circ C$ $T_j = 125^\circ C$		1.3	2.1 1.9	V V
I_R **	Reverse leakage current	$V_R = 0.8$ $\times V_{RRM}$ $T_j = 25^\circ C$ $T_j = 125^\circ C$		2.0	150 8	μA mA
V_{to}	Threshold voltage	$T_j = 125^\circ C$			1.52	V
R_d	Dynamic resistance				15	m Ω

Test pulses widths : * $t_p = 380 \mu s$, $\delta < 2\%$

** $t_p = 5 ms$, $\delta < 2\%$

DYNAMIC ELECTRICAL CHARACTERISTICS

TURN-OFF SWITCHING (see Fig. 7)

Symbol	Parameter	Test Conditions	Min	Typ	Max	Unit
t_{rr}	Reverse recovery time	$T_j = 25^\circ C$ $I_F = 0.5 A$ $I_R = 1A$ $I_{rr} = 0.25A$ $I_F = 1 A$ $di_F/dt = -50A/\mu s$ $V_R = 30V$		60	110	ns
I_{RM}	Maximum reverse recovery current	$T_j = 125^\circ C$ $V_R = 600V$ $I_F = 25A$ $di_F/dt = -200 A/\mu s$ $di_F/dt = -500 A/\mu s$		45	35	A
S factor	Softness factor	$T_j = 125^\circ C$ $V_R = 600V$ $I_F = 25A$ $di_F/dt = -500 A/\mu s$		1.2		/

TURN-ON SWITCHING (see Fig. 8)

Symbol	Parameter	Test Conditions	Min	Typ	Max	Unit
t_{fr}	Forward recovery time	$T_j = 25^\circ C$ $I_F = 25 A$, $di_F/dt = 200 A/\mu s$ measured at $1.1 \times V_{Fmax}$			900	ns
V_{Fp}	Peak forward voltage	$T_j = 25^\circ C$ $I_F = 25A$, $di_F/dt = 200 A/\mu s$ $I_F = 40A$, $di_F/dt = 500 A/\mu s$		35	30	V

APPLICATION DATA

The 1200V TURBOSWITCH series has been designed to provide the lowest overall power losses in all high frequency or high pulsed current operations. In such applications (Fig 1 to 5), the way of calculating the power losses is given below :

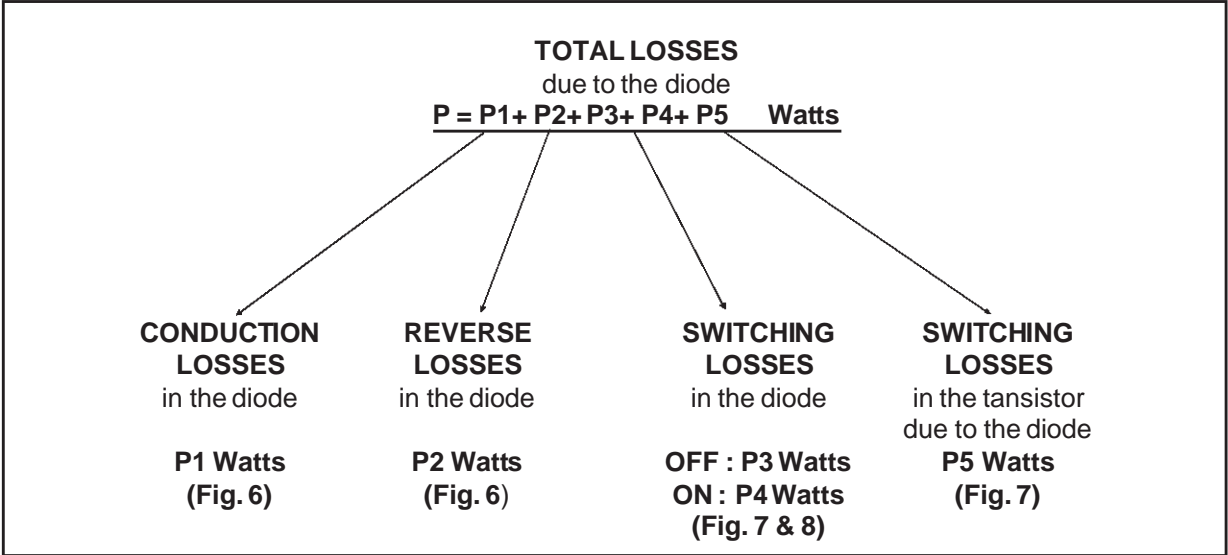

Fig. 1 : "FREEWHEEL" MODE.

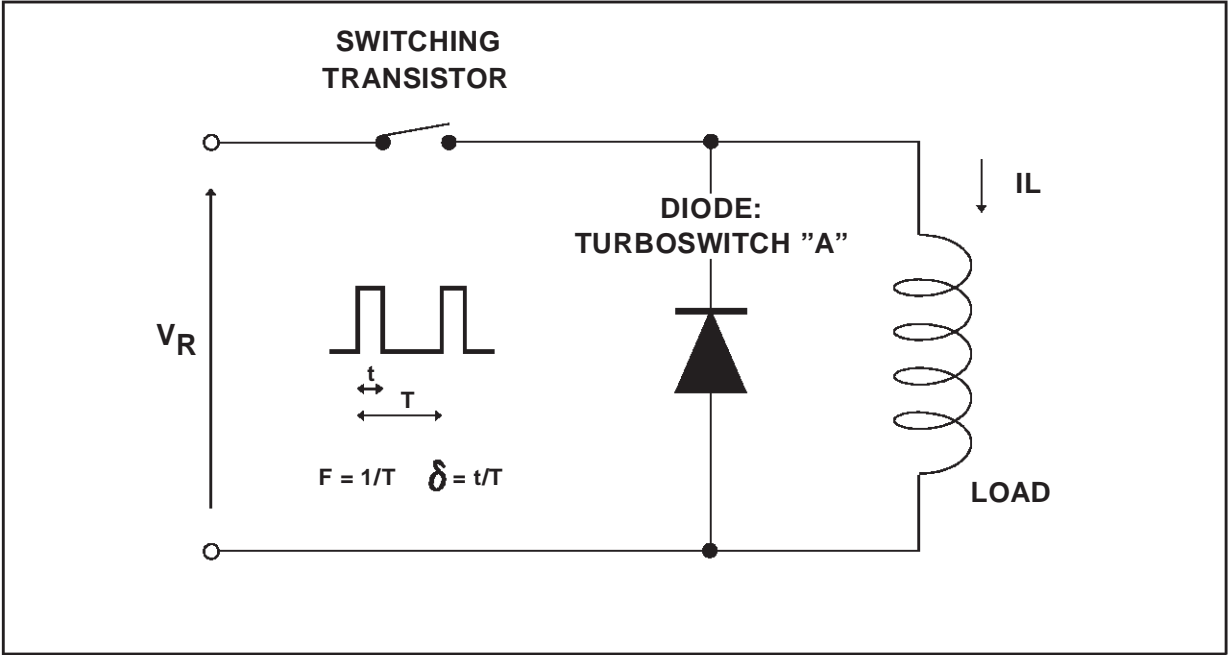

Fig. 2 : SNUBBER DIODE.

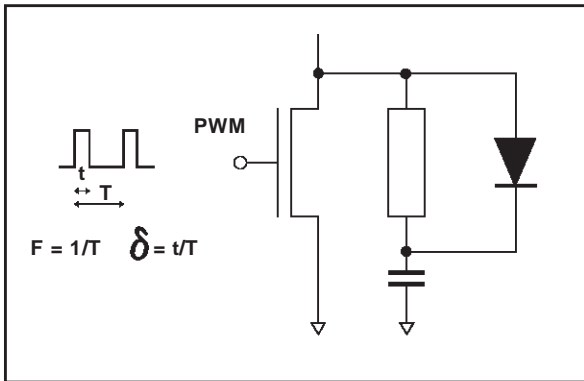

Fig. 3 : CLAMPING DIODE.

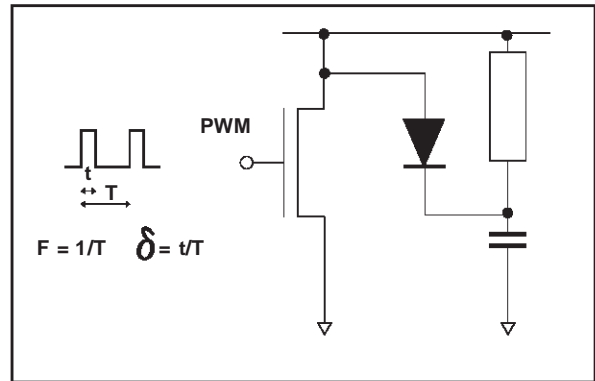

Fig. 4 : DEMAGNETIZING DIODE.

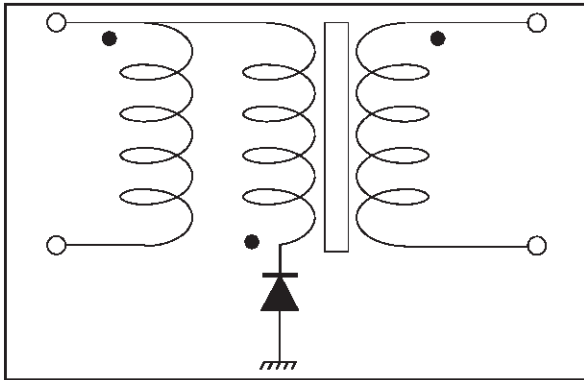
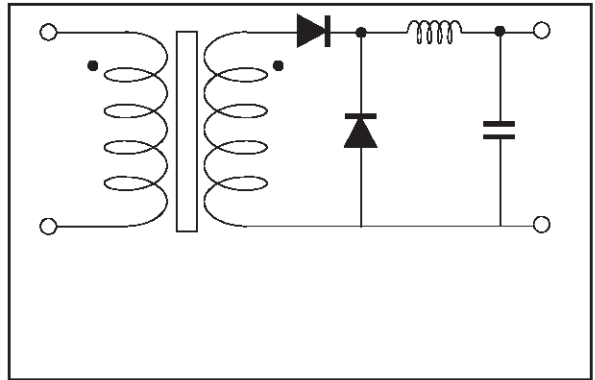
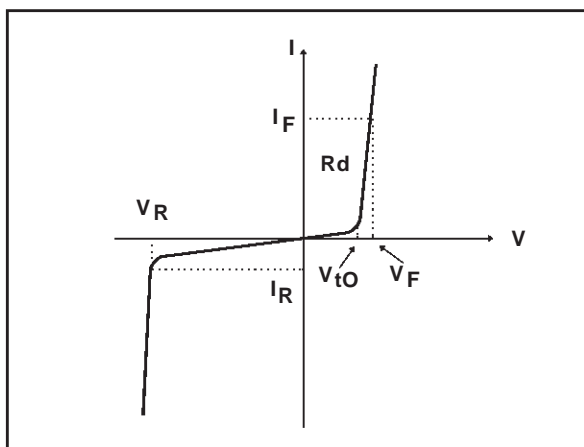

Fig. 5 : RECTIFIER DIODE.



STATIC & DYNAMIC CHARACTERISTICS . POWER LOSSES .

Fig. 6: STATIC CHARACTERISTICS



Conduction losses :

$$P1 = V_{t0} \cdot I_F(AV) + R_d \cdot I_F^2(RMS)$$

Max values at 125°C, suitable for $I_{peak} < 3 \cdot I_F(av)$

Reverse losses :

$$P2 = V_R \cdot I_R \cdot (1 - \delta)$$

APPLICATION DATA (Cont'd)

Fig. 7: TURN-OFF CHARACTERISTICS

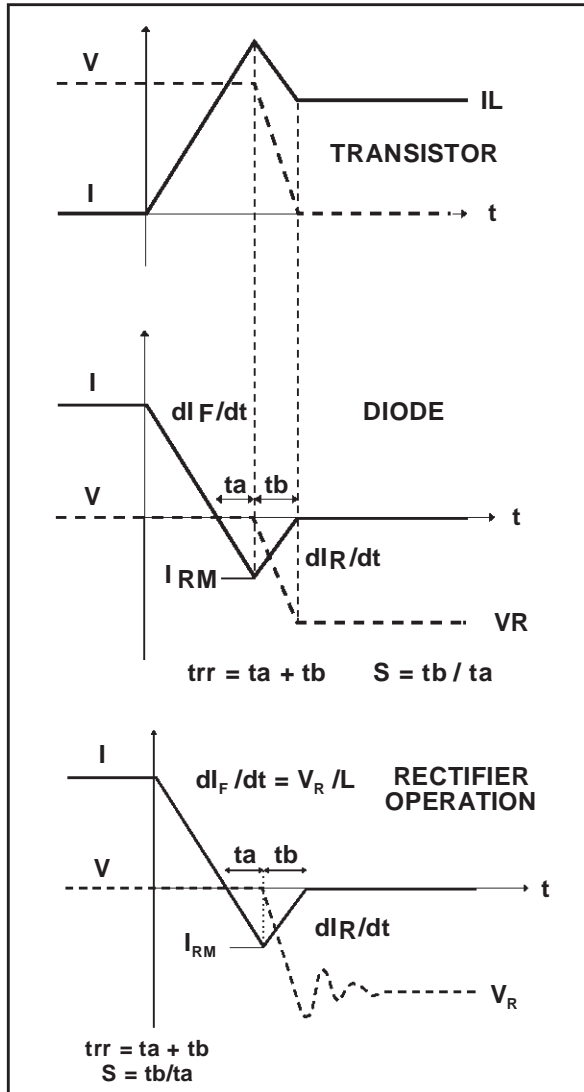

Turn-on losses:
(in the transistor, due to the diode)

$$P5 = \frac{V_R \times I_{RM}^2 \times (3 + 2 \times S) \times F}{6 \times dI/dt} + \frac{V_R \times I_{RM} \times I_L \times (S + 2) \times F}{2 \times dI/dt}$$

Turn-off losses (in the diode):

$$P3 = \frac{V_R \times I_{RM}^2 \times S \times F}{6 \times dI/dt}$$

Turn-off losses:
(with non negligible serial inductance)

$$P3' = \frac{V_R \times I_{RM}^2 \times S \times F}{6 \times dI/dt} + \frac{L \times I_{RM}^2 \times F}{2}$$

P3, P3' and P5 are suitable for power MOSFET and IGBT

Fig. 8: TURN-ON CHARACTERISTICS

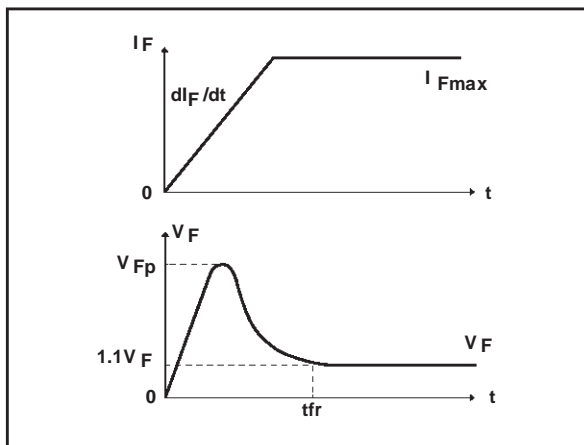

Turn-on losses:

$$P4 = 0.4 (V_{FP} - V_F) \cdot I_{Fmax} \cdot t_{fr} \cdot F$$

Fig. 9: Conduction losses versus average current (per diode).

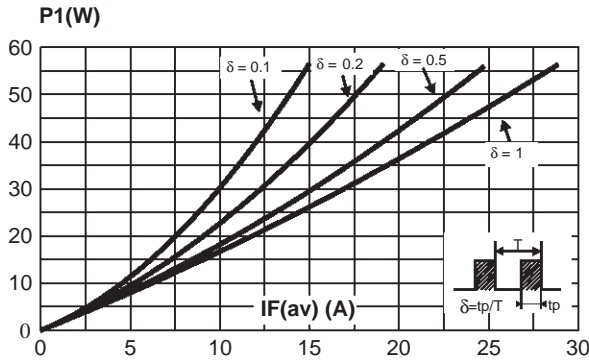

Fig. 11: Switching ON losses versus dIF/dt .

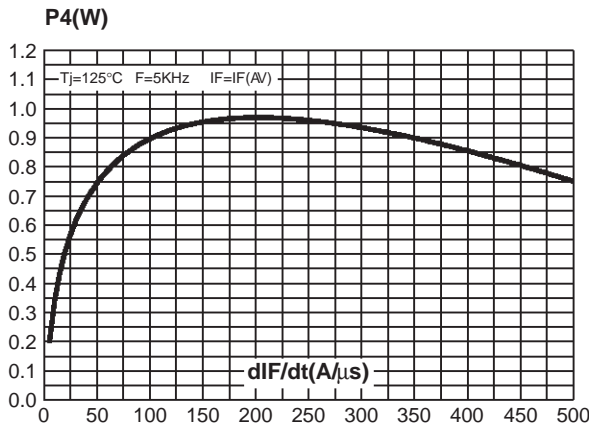

Fig. 13: Forward voltage drop versus forward current (maximum values, per diode).

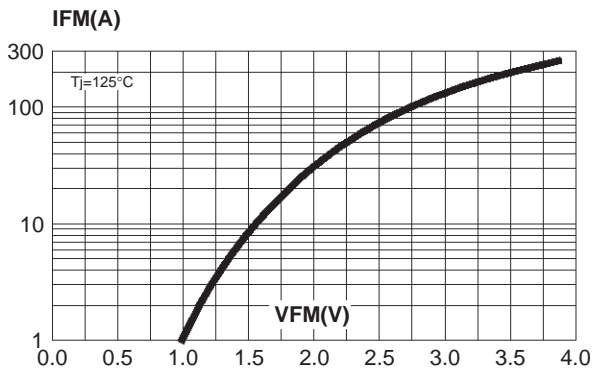

Fig. 10: Switching OFF losses versus dIF/dt .

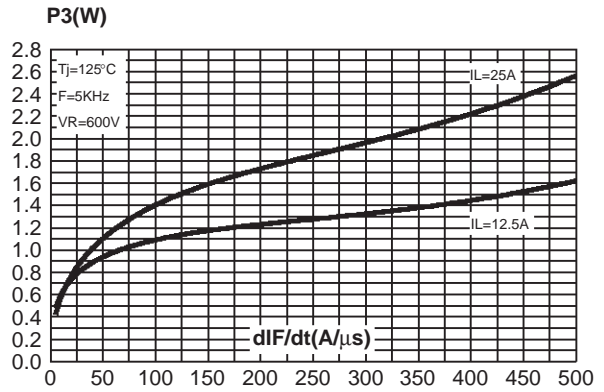

Fig. 12: Switching losses in transistor due to the diode.

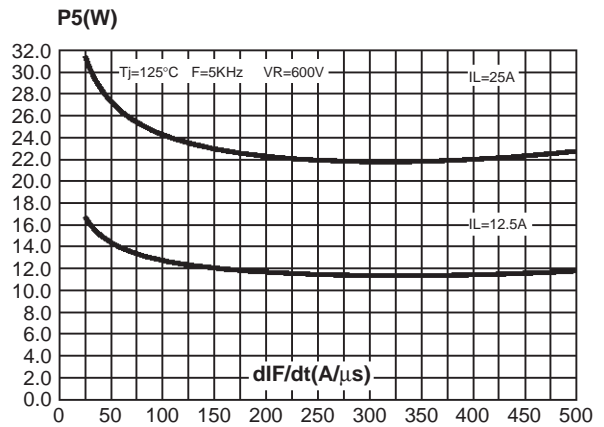

Fig. 14: Relative variation of thermal impedance junction to case versus pulse duration (per diode).

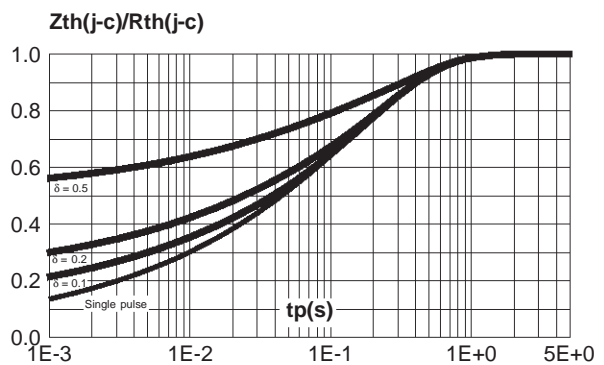

Fig. 15: Peak reverse recovery current versus dI_F/dt (90% confidence, per diode).

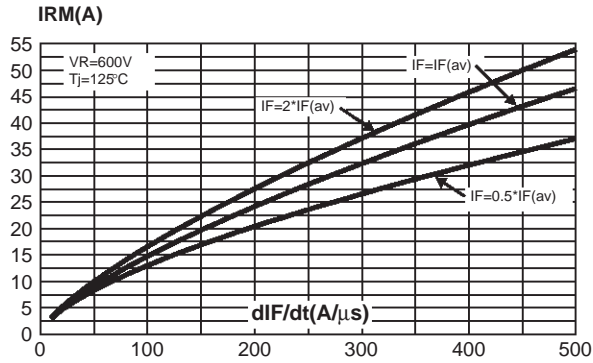

Fig. 16: Reverse recovery time versus dI_F/dt (90% confidence, per diode).

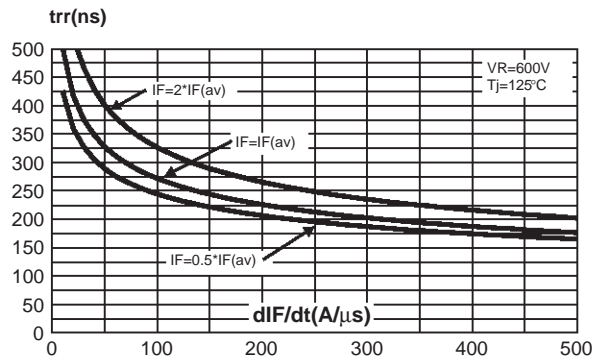

Fig. 17: Softness factor (t_b/t_a) versus dI_F/dt (typical values, per diode).

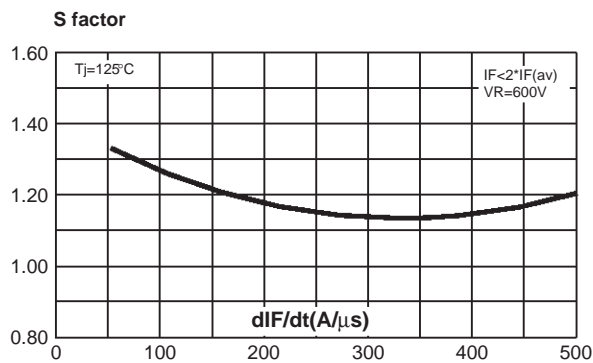

Fig. 18: Relative variation of dynamic parameters versus junction temperature (reference $T_j=125^\circ\text{C}$).

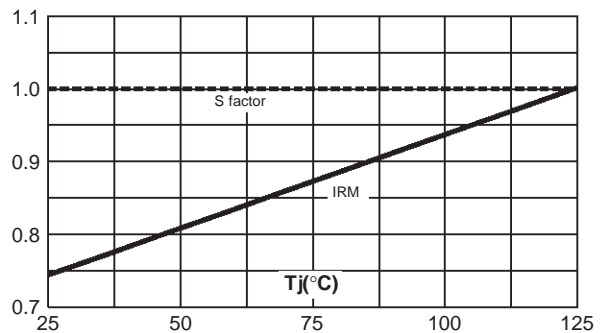

Fig. 19: Transient peak forward voltage versus dI_F/dt (90% confidence, per diode).

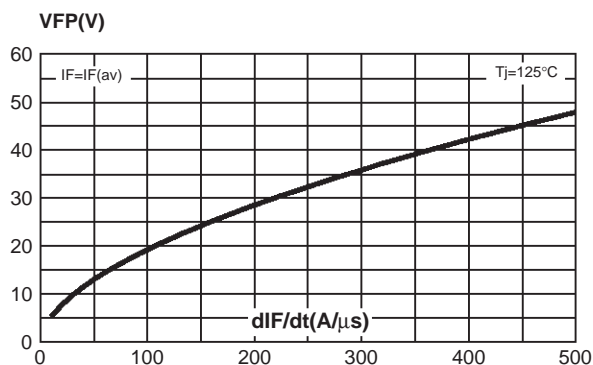
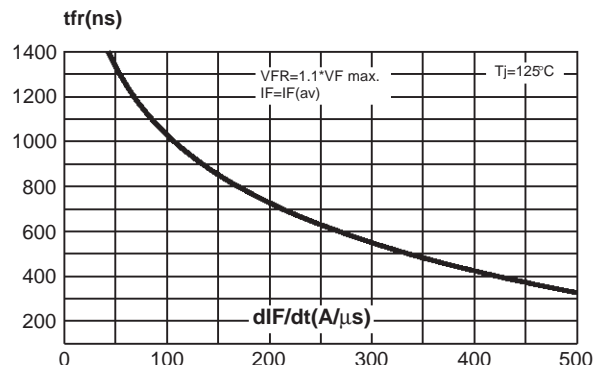
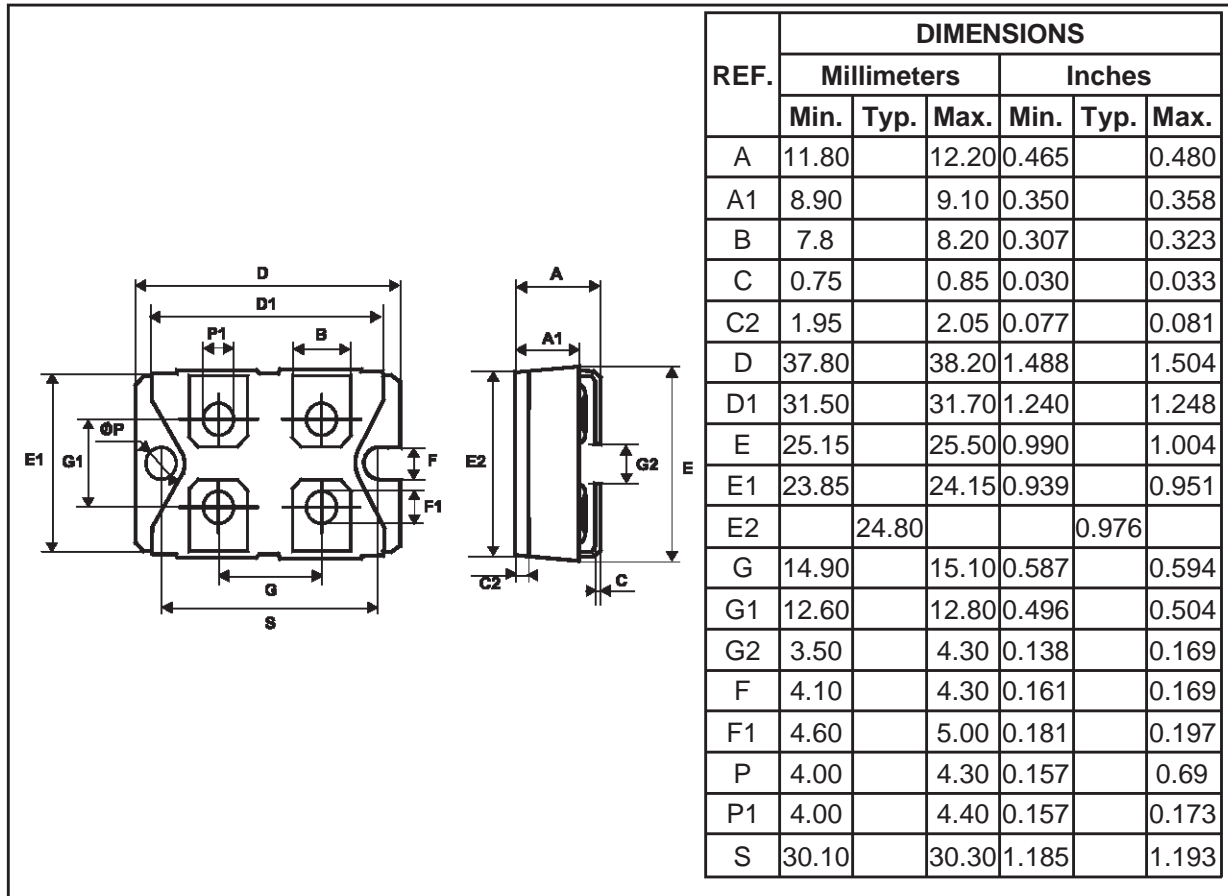

Fig. 20: Forward recovery time versus dI_F/dt (90% confidence, per diode).



STTA5012TV1/2

PACKAGE MECHANICAL DATA ISOTOP



- **Marking:** Type number
- Cooling method: C
- Weight: 28 g (without screws)
- Electric isolation: 2500V_(RMS)
- Capacitance: < 45 pF
- Inductance: < 5 nH
- Recommended torque value: 1.3 N.m (MAX 1.5 N.m) for the 6 x M4 screws. (2 x M4 screws recommended for mounting the package on the heatsink and the 4 screws given with the screw version).
- The screws supplied with the package are adapted for mounting on a board (or other types of terminals) with a thickness of 0.6 mm min and 2.2 mm max.

Information furnished is believed to be accurate and reliable. However, STMicroelectronics assumes no responsibility for the consequences of use of such information nor for any infringement of patents or other rights of third parties which may result from its use. No license is granted by implication or otherwise under any patent or patent rights of STMicroelectronics. Specifications mentioned in this publication are subject to change without notice. This publication supersedes and replaces all information previously supplied. STMicroelectronics products are not authorized for use as critical components in life support devices or systems without express written approval of STMicroelectronics.

The ST logo is a registered trademark of STMicroelectronics

© 1998 STMicroelectronics - Printed in Italy - All rights reserved.

STMicroelectronics GROUP OF COMPANIES

Australia - Brazil - Canada - China - France - Germany - Italy - Japan - Korea - Malaysia - Malta - Mexico - Morocco - The Netherlands - Singapore - Spain - Sweden - Switzerland - Taiwan - Thailand - United Kingdom - U.S.A.