

ASSP

CMOS

# 3 V Single Power Supply Audio Interface Unit (AIU)

## MB86435

### ■ DESCRIPTION

The FUJITSU MB86435 is an AIU (audio interface unit) LSI for +3 V single-power source digital telephone devices, manufactured using CMOS process technology. The codec transmission filter characteristics meet G.712 standards, and can handle input and output in A-Law,  $\mu$ -Law and linear conversion modes. The MB86435 also contains the necessary DTMF, microphone and receiver amps for telephone devices.

### ■ FEATURES

- +3 V single power supply
- Low power consumption: muting settings for each operating mode
  - Normal operation : 6.0 mA TYP (speaker amp mute)
  - Tone generation : 1.8 mA TYP (speaker amp mute)
  - Standby mode : 0.5  $\mu$ A TYP
- On-chip codec filter meets G.712 standards
- Selection of codec conversion methods (A-law,  $\mu$ -law, linear)
- On-chip low-noise microphone amp (2-channel) (0 to 35 dB amplification)
- On-chip receiver speaker amps (32  $\Omega$ BTL type: 6.4 mW MIN)
- On-chip tone speaker amp (25  $\Omega$ BTL type: 10 mW MIN)
- On-chip earphone speaker amps (32  $\Omega$  single type: 2 mW MIN)

*(Continued)*

### ■ PACKAGE

64 pin, Plastic LQFP

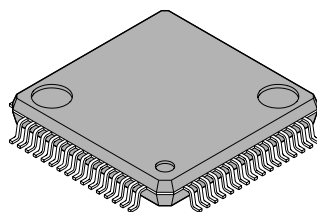

(FPT-64P-M03)

# MB86435

(Continued)

- On-chip electronic volume gain adjustments (sending, receiving, tone)
- On-chip accessory input/output circuits
- DTMF generator function
- Service tone generation
- CMOS compatible input/output

## ■ PIN ASSIGNMENT

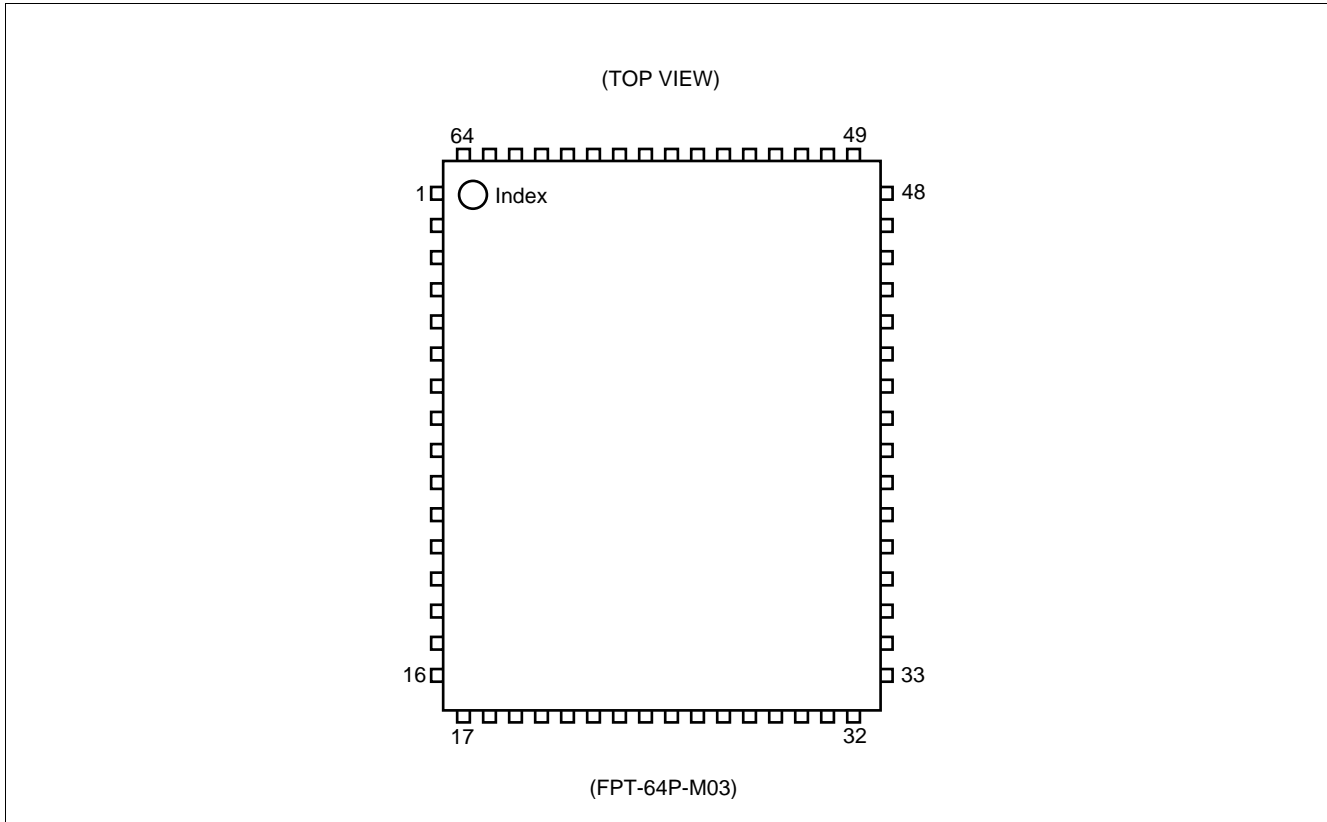

## MB86435

## ■ PIN DESCRIPTION

Pin No.	Symbol	I/O	A/D	Description	
1	VRH	O	A	Bypass capacitor connector pin for the A/D D/A reference voltage generator circuit. Place capacitor between VRH and CAG pins.	
2	SGC	O	A	Bypass capacitor connector pin for the signal ground potential generator circuit. Place capacitor between SGC and CAG pins.	
3	VDDAC	P	A	Analog power supply pin for codec block. To be set within range 2.7 to 3.6 V.	
6	SYNC	I	D	PCM codec send/receive synchronization signal input pin. Operating clock frequency 8 kHz. CMOS interface. Constant H/L level signal will cause part of codec block to power-down.	
7	CLK	I	D	Send/receive PCM signal series bit rate setting input pin. Data rate for $\mu$ -law, A-law modes may be set to any level in the range 64 k to 3.152 MHz, and for linear mode in the range 256 k to 3.152 MHz. Constant H or L level signal will cause part of codec block to power-down. CMOS interface.	
8	DIN	I	D	PCM signal input pin. This signal is picked up internally at the fall of the CLK signal. CMOS interface.	
9	DOUT	O	D	PCM signal output pin. Data is output in sync with the rise of the CLK signal. After data output, loses PLL synchronization, and at power-down this signal is fixed at H level. CMOS interface.	
10	VDD	P	D	Digital power supply pin. To be set within range 2.7 to 3.6 V.	
11	DG	G	D	Digital ground pin. To be set to 0V.	
12	PSC0	I	D	Power-down control signal input pin. CMOS interface. Used with PSC1,2 pins for power-down settings.	PSC 2 1 0 0 0 0 Full power-down 1 0 0 $V_{REF}$ operating — 1 0 Tone operating — — 1 All operations available (—: value not determined)
13	PSC1	I	D	Power-down control signal input pin. CMOS interface. Used with PSC0,2 pins for power-down settings.	
14	PSC2	I	D	Power-down control signal input pin. CMOS interface. Used with PSC0,1 pins for power-down settings.	
15	SRD	I	D	9-bit serial data input pin. CMOS interface. Data is written at the rise of the signal from this pin.	
16	SRC	I	D	Clock input pin for 9-bit serial data writing. CMOS interface. Data is written at the rise of this pin.	
17	STB	I	D	Serial data latch strobe signal. Data is latched by the L level signal. CMOS interface.	
18	XPRST	I	D	Digital reset signal input pin. CMOS interface. L level: internal latch initialization H level: normal operation	
19	LO0	O	D	External control latch output pin. Outputs value $D_0$ of address 1000. CMOS interface.	
20	LO1	O	D	External control latch output pin. Outputs value $D_1$ of address 1000. CMOS interface.	

(Continued)

## MB86435

Pin No.	Symbol	I/O	A/D	Description
21	LO2	O	D	External control latch output pin. Outputs value D <sub>2</sub> of address 1000. CMOS interface.
22	LO3	O	D	External control latch output pin. Outputs value D <sub>3</sub> of address 1000. CMOS interface.
23	TCLK	I	D	Tone generator clock input pin. Can be used as a tone CLK signal by using address 1110 D4D3 to subdivide the internal clock signal by factors of 1/1, 1/2, 1/4. CMOS interface.
24	TONC	I	D	Tone generator cycle control input pin. CMOS interface. Hlevel signal outputs tone.
25	LED	O	D	Ring LED control output pin. CMOS interface.
26	DSCK	I/O	A	Can be connected to EXSD or TAUD by switching bus.
27	EXSD	I/O	A	Can be connected to DSCK or TAUD by switching bus.
28	TAUD	I/O	A	Can be connected to EXSD or DSCK by switching bus.
29	DSDT	I	A	Can be connected to RAUD by switching bus.
30	TONEO	O	A	Tone signal output pin.
31	RAUD	O	A	Output pin for external speaker, or audio test signal. Can be connected to DSDT by switching paths.
32	VDDSP1	P	A	Speaker amp power supply pin. To be set within range 2.7 to 3.6 V.
33	JEAR		O	Earphone speaker amp output pin. Capable of 2 mW output at 32 Ω load.
34	XEAR	O	A	Receiver speaker amp output pin. Internally connected to EAR and BTL. Maximum output of 6.4 mW can be obtained at 32 Ω load by connecting speaker between EAR and XEAR.
35	EAR	O	A	Receiver speaker amp output pin. Connected to XEAR and BTL.
36	SPG1	G	A	Speaker amp ground pin. To be set to 0 V.
37	SPG2	G	A	Speaker amp ground pin. To be set to 0 V.
38	XTONE	O	A	Speaker amp tone output pin. Internally connected to TONE and BLT. Maximum output of 10 mW can be obtained at 25 Ω load by connecting speaker between TONE and XTONE.
39	TONE	O	A	Speaker amp tone output pin. When speaker amp is not used for tone, TONE should be shorted to IMTON.
40	IMTON	I	A	Speaker drive inverted (–) signal input pin. Can be used to adjust gain by connecting resistance to TONE and IMTON.
41	VDDSP2	P	A	Speaker amp power supply pin. To be set within range 2.7 to 3.6 V.
42	BBI	O	A	AMP3 output pin. Should be included in HPF together with IM3, to prevent DC offset from entering speakers.
43	IM3	I	A	AMP3 inverted (–) signal input pin.
44	BTO	O	A	Receiving volume adjustment circuit output pin.

(Continued)

## MB86435

(Continued)

Pin No.	Symbol	I/O	A/D	Description
45	OP2	O	A	AMP2 output pin. If AMP2 is not used, IM2 should be shorted to OP2.
46	IM2	I	A	AMP2 inverted (–) signal input pin. Can form a circuit with OP2 to add sidetone or tone. Melody circuits, if used, can also be connected here.
47	OP1	O	A	AMP1 output pin. Can form a circuit with IM1 to include LPF or HPF in receiving block. If AMP1 is not used, IM1 should be shorted to OP1.
48	IM1	I	A	AMP1 inverted (–) signal input pin.
49	PTBO	O	A	PCM receiver output pin.
50	BAG	G	A	Analog ground pin for sending, receiving blocks. To be set to 0 V.
51	VDDAB	P	A	Analog power supply pin for sending, receiving blocks. To be set within range 2.7 to 3.6 V.
52	XJMIC	I	A	Microphone amp (2) non-inverted (+) signal input pin.
53	JMIC	I	A	Microphone amp (2) inverted (–) signal input pin.
54	JMICO	O	A	Microphone amp (2) output pin.
55	XMICI	I	A	Microphone amp (1) non-inverted (+) signal input pin.
56	MIC	I	A	Microphone amp (1) inverted (–) signal input pin.
57	MICO	O	A	Microphone amp (1) output pin.
58	SGO	O	A	Sending block signal ground potential output pin. Buffers SGC voltage.
59	BBO	O	A	Sending analog signal output pin.
62	BTPI	I	A	PCM ENCODE block input OP amp negative input pin.
63	BTPO	O	A	PCM ENCODE block input OP amp output pin.
64	CAG	G	A	Analog ground pin for codec block. To be set to 0 V.
4, 5, 60, 61	NC	—	—	Not connected. To be left open.

# MB86435

## ■ BLOCK DIAGRAM

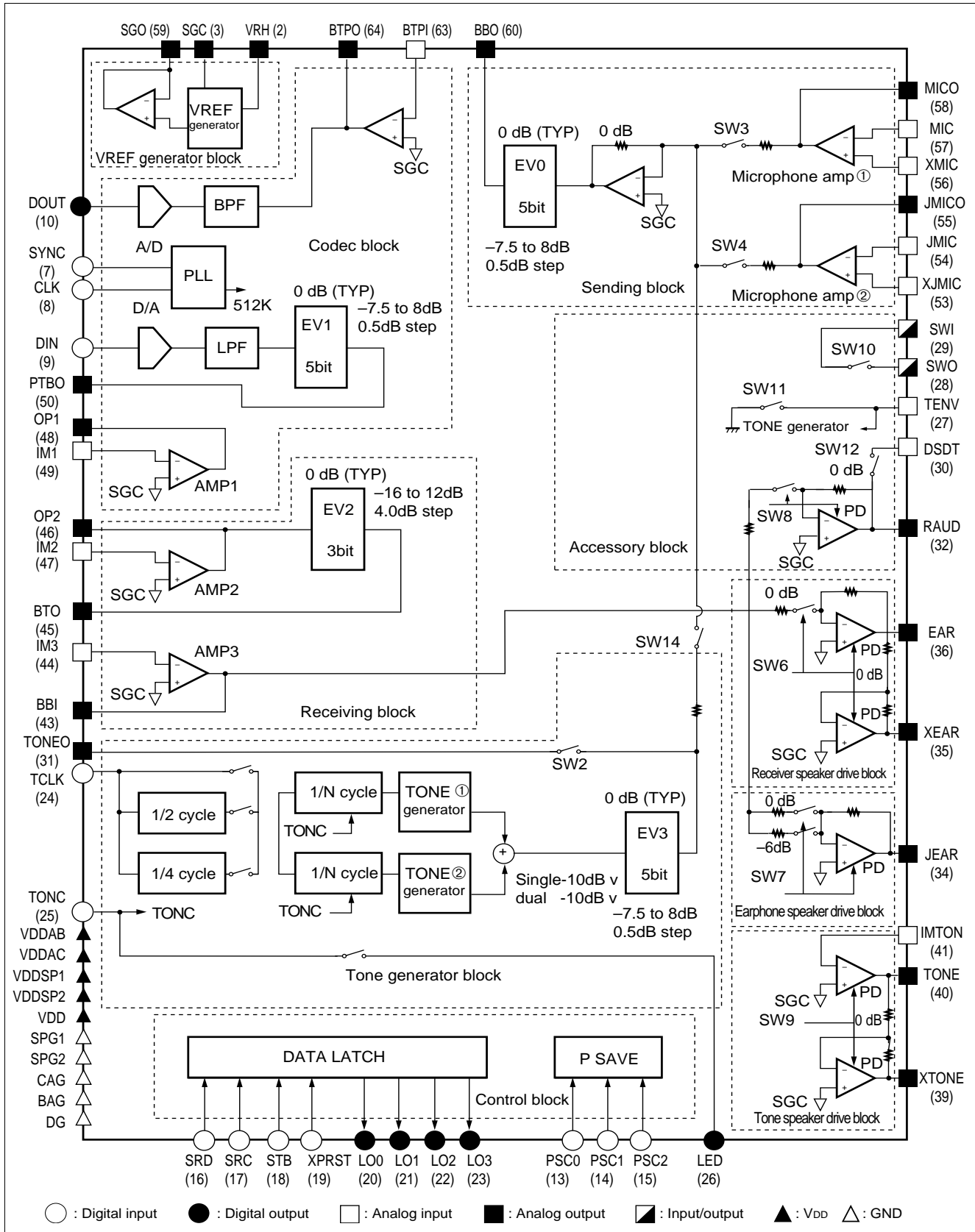

## MB86435

## ■ FUNCTIONAL DESCRIPTION

### 1. Register Settings

The MB86435 IC chip controls all electronic volume, switching, tone generator circuits and power-down control circuits by means of the SRD, STB and SRC data input signals.

The MB86435 uses a 9-bit serial data format consisting of a 4-bit address followed by 5 data bits. Data is picked up at the rise of the SRC signal, and latched by the STB L-level signal. The 9-bits of serial data preceding the STB signal are considered valid. These register settings are not reset at power-down. They can be reset when data is initialized by an XPRST L-level signal.

#### (1) Mode Settings

Control segment	Address				Data bit					Setting description	Initial data bit setting (at reset)					Remarks
	A <sub>3</sub>	A <sub>2</sub>	A <sub>1</sub>	A <sub>0</sub>	D <sub>4</sub>	D <sub>3</sub>	D <sub>2</sub>	D <sub>1</sub>	D <sub>0</sub>		D <sub>4</sub>	D <sub>3</sub>	D <sub>2</sub>	D <sub>1</sub>	D <sub>0</sub>	
EV0	0	0	0	1	D <sub>4</sub>	D <sub>3</sub>	D <sub>2</sub>	D <sub>1</sub>	D <sub>0</sub>	Sending audio level adjustment. Adjusts EV0 gain.	0	1	1	1	1	
EV1	0	0	1	0	D <sub>4</sub>	D <sub>3</sub>	D <sub>2</sub>	D <sub>1</sub>	D <sub>0</sub>	Sending audio level adjustment. Adjusts EV1 gain.	0	1	1	1	1	*1
EV2	0	0	1	1	*	*	D <sub>2</sub>	D <sub>1</sub>	D <sub>0</sub>	Sending audio level adjustment. Adjusts EV2 gain.	*	*	1	0	0	
TX-MUTE	0	1	0	0	D <sub>4</sub>	*	*	*	D <sub>0</sub>	D <sub>0</sub> : Sending audio mute SW 3, 4, 5 on/off control. Mute: 1, Unmute: 0	0	*	*	*	0	*2, *3
RX-MUTE										D <sub>4</sub> : Sending audio mute SW 6, 7, 8, 9 on/off control. Mute: 1, Unmute: 0						*3, *4
SW5	0	1	0	1	D <sub>4</sub>	*	D <sub>2</sub>	D <sub>1</sub>	D <sub>0</sub>	D <sub>0</sub> : TAUD mute SW 5 on/off control. Mute: 1, Unmute: 0	0	*	0	0	0	*2, *5
SW4										D <sub>1</sub> : JMIC mute SW 4 on/off control. Mute: 1, Unmute: 0						*2
SW3										D <sub>2</sub> : MIC mute SW 3 on/off control. Mute: 1, Unmute: 0						
SW8										D <sub>4</sub> : RAUD mute SW 8 on/off control. Mute: 1, Unmute: 0						*3, *4, *6
SW6	0	1	1	0	D <sub>4</sub>	*	D <sub>2</sub>	D <sub>1</sub>	D <sub>0</sub>	D <sub>0</sub> : EAR, XEAR mute SW 6 on/off control. Mute: 1, Unmute: 0	0	*	0	0	0	*4
SW9										D <sub>1</sub> : TONE, XTONE mute SW 9 on/off control. Mute: 1, Unmute: 0						
SW7										D <sub>2</sub> : JEAR mute SW 7 on/off control. Mute: 1, Unmute: 0						
ATT										D <sub>4</sub> : JEAR attenuation level switch. 0: -2.5 dB, 1: -8.5 dB.						

(Continued)

## MB86435

(Continued)

Control segment	Address				Data bit				Setting description	Initial data bit setting (at reset)				Remarks			
	A <sub>3</sub>	A <sub>2</sub>	A <sub>1</sub>	A <sub>0</sub>	D <sub>4</sub>	D <sub>3</sub>	D <sub>2</sub>	D <sub>1</sub>		D <sub>0</sub>	D <sub>4</sub>	D <sub>3</sub>	D <sub>2</sub>		D <sub>1</sub>	D <sub>0</sub>	
SW10									D <sub>0</sub> : EXSD pin selection SW 10 on/off control. On: 1, Off: 0						*3, *5		
SW12									D <sub>1</sub> : DSDT pin selection SW 12 on/off control. On: 1, Off: 0						*3, *6		
SW11	0	1	1	1	D <sub>4</sub>	D <sub>3</sub>	D <sub>2</sub>	D <sub>1</sub>	D <sub>0</sub>	D <sub>2</sub> : DSCK pin selection SW 12 on/off On: 1, Off: 0	0	0	0	0	0	*3, *5	
SW2										D <sub>3</sub> : TONEO mute SW 2 on/off control. Mute: 1, Unmute: 0						*7	
SW14										D <sub>4</sub> : TONE sending add SW 14 on/off control. On: 1, Off: 0							
Serial/ parallel converter	1	0	0	0	*	D <sub>3</sub>	D <sub>2</sub>	D <sub>1</sub>	D <sub>0</sub>	Parallel output D <sub>3</sub> = LO3, D <sub>2</sub> = LO2, D <sub>1</sub> = LO1, D <sub>0</sub> = LO0	*	0	0	0	0	*8	
EV3	1	0	0	1	D <sub>4</sub>	D <sub>3</sub>	D <sub>2</sub>	D <sub>1</sub>	D <sub>0</sub>	Tone level adjustment. Adjusts EV3 gain.	0	1	1	1	1	*1	
TONE control	Fre- quency control	1	0	1	0	X <sub>8</sub>	X <sub>7</sub>	X <sub>6</sub>	X <sub>5</sub>	X <sub>4</sub>	Tone (1) frequency control, set by 8-bit value X <sub>7</sub> to X <sub>0</sub> .	0	0	0	0	0	*9, *10
		1	0	1	1	*	X <sub>3</sub>	X <sub>2</sub>	X <sub>1</sub>	X <sub>0</sub>	X <sub>8</sub> = 1 to output trapezoidal wave, X <sub>8</sub> = 0 to output sine wave.	*	0	0	1	0	
		1	1	0	0	Y <sub>8</sub>	Y <sub>7</sub>	Y <sub>6</sub>	Y <sub>5</sub>	Y <sub>4</sub>	Tone (2) frequency control, set by 8-bit value Y <sub>7</sub> to Y <sub>0</sub> .	0	0	0	0	0	
		1	1	0	1	*	Y <sub>3</sub>	Y <sub>2</sub>	Y <sub>1</sub>	Y <sub>0</sub>	Y <sub>8</sub> = 1 to output trapezoidal wave, Y <sub>8</sub> = 0 to output sine wave.	*	0	0	1	0	
	Output control										Tone generator control D <sub>0</sub> : tone (2) on/off control. On: 1, off: 0 D <sub>1</sub> : tone (1) on/off control. On: 1, off: 0 D <sub>2</sub> : LED output on/off control. On: 1, off: 0						*7, *11, *12
		Master clock control										Tone CLK D <sub>4</sub> , D <sub>3</sub> 0 0 : TCLK1/1 frequency selected 0 1 : TCLK1/2 frequency selected 1 0 : TCLK1/4 frequency selected 1 1 : Prohibited	0	0	1	1	1
PCM	1		1	1	1	*	*	*	D <sub>1</sub>	D <sub>0</sub>	PCM control D <sub>1</sub> , D <sub>0</sub> 0 0 : μ-law mode selected 1 0 : A-law mode selected 0 1 : linear mode selected	*	*	*	0	0	*13, *14
TEST	0	0	0	0	D <sub>4</sub>	D <sub>3</sub>	D <sub>2</sub>	D <sub>1</sub>	D <sub>0</sub>	Do not write in test mode.	0	0	0	0	0		

(Continued)



- \*1: See (4) Electronic Volume Controls
- \*2: See (2) Sending Audio Mute Setting
- \*3: See 5. Power Saving Modes
- \*4: See (3) Receiving Audio Mute Settings
- \*5: See 2. Analog Input (2) Accessory Input
- \*6: See 3. Analog Output (2) Accessory Output
- \*7: See (5) Tone Generator Circuit • Tone Generator Control Output Level
- \*8: See (8) Parallel Output
- \*9: See (5) Tone Generator Circuit • Tone Frequency Control Registers
- \*10: See (5) Tone Generator Circuit • Tone Output Waveforms
- \*11: See (5) Tone Generator Circuit • Tone Output Controls
- \*12: See (5) Tone Generator Circuit • LED Output Controls
- \*13: See (6) Codec Input/Output
- \*14: See (7) The Codec SYNC Pin

# MB86435

## (2) Sending Audio Mute Settings

Switches SW 3 to SW 5 have the following functions. Address 0100 signals have priority.

Address	Setting								Switching setting				
	A <sub>3</sub>	A <sub>2</sub>	A <sub>1</sub>	A <sub>0</sub>	A <sub>3</sub>	A <sub>2</sub>	A <sub>1</sub>	A <sub>0</sub>					
	0	1	0	0	0	1	0	0					
Data bit	D <sub>4</sub>	D <sub>3</sub>	D <sub>2</sub>	D <sub>1</sub>	D <sub>0</sub>	D <sub>4</sub>	D <sub>3</sub>	D <sub>2</sub>	D <sub>1</sub>	D <sub>0</sub>	SW3	SW4	SW5
	—	*	*	*	1	—	*	—	—	—	○	○	○
	—	*	*	*	0	—	*	—	—	1	—	—	○
	—	*	*	*	0	—	*	—	1	—	—	○	—
	—	*	*	*	0	—	*	1	—	—	○	—	—
	—	*	*	*	0	—	*	—	—	0	—	—	×
	—	*	*	*	0	—	*	—	0	—	—	×	—
	—	*	*	*	0	—	*	0	—	—	×	—	—

○ : muted, × : unmuted, — : not determined

## (3) Receiving Audio Mute Settings

Switches SW 6 to SW 9 have the following functions. Address 0100 signals have priority.

Address	Setting												Switching setting						
	A <sub>3</sub>	A <sub>2</sub>	A <sub>1</sub>	A <sub>0</sub>	A <sub>3</sub>	A <sub>2</sub>	A <sub>1</sub>	A <sub>0</sub>	A <sub>3</sub>	A <sub>2</sub>	A <sub>1</sub>	A <sub>0</sub>							
	0	1	0	0	0	1	0	1	0	1	1	0							
Data bit	D <sub>4</sub>	D <sub>3</sub>	D <sub>2</sub>	D <sub>1</sub>	D <sub>0</sub>	D <sub>4</sub>	D <sub>3</sub>	D <sub>2</sub>	D <sub>1</sub>	D <sub>0</sub>	D <sub>4</sub>	D <sub>3</sub>	D <sub>2</sub>	D <sub>1</sub>	D <sub>0</sub>	SW8	SW7	SW9	SW6
	1	*	*	*	—	—	*	—	—	—	—	*	—	—	—	○	○	○	○
	0	*	*	*	—	—	*	—	—	—	—	*	—	—	1	—	—	—	○
	0	*	*	*	—	—	*	—	—	—	—	*	—	1	—	—	—	○	—
	0	*	*	*	—	—	*	—	—	—	—	*	1	—	—	—	○	—	—
	0	*	*	*	—	1	*	—	—	—	—	*	—	—	—	○	—	—	—
	0	*	*	*	—	—	*	—	—	—	—	*	—	—	0	—	—	—	×
	0	*	*	*	—	—	*	—	—	—	—	*	—	0	—	—	—	×	—
	0	*	*	*	—	—	*	—	—	—	—	*	0	—	—	—	×	—	—
	0	*	*	*	—	0	*	—	—	—	—	*	—	—	—	×	—	—	—

○ : muted, × : unmuted, — : not determined

## MB86435

## (4) Electronic Volume Controls

There are four different electronic volume controls, EV0 through EV3, with the following specifications. Electronic volume control settings are made by the SRD, SRC and STB signals, and setting values are reset by the XPRST signal. However, settings are not reset by PSC0, PSC1, PSC2 power-down mode operations.

Table 1 Relation of Volume Control Data bit Values to Gain

Step	Data bit value					EV0 sending gain adjustment	EV1 sending gain adjustment	EV2 sending gain adjustment	EV3 sending gain adjustment	Unit
	D <sub>4</sub>	D <sub>3</sub>	D <sub>2</sub>	D <sub>1</sub>	D <sub>0</sub>	Typ.	Typ.	Typ.	Typ.	
0	0	0	0	0	0	-7.5	-7.5	-16	-7.5	dB
1	0	0	0	0	1	-7.0	-7.0	-12	-7.0	
2	0	0	0	1	0	-6.5	-6.5	-8	-6.5	
3	0	0	0	1	1	-6.0	-6.0	-4	-6.0	
4	0	0	1	0	0	-5.5	-5.5	0	-5.5	
5	0	0	1	0	1	-5.0	-5.0	4	-5.0	
6	0	0	1	1	0	-4.5	-4.5	8	-4.5	
7	0	0	1	1	1	-4.0	-4.0	12	-4.0	
8	0	1	0	0	0	-3.5	-3.5		-3.5	
9	0	1	0	0	1	-3.0	-3.0		-3.0	
10	0	1	0	1	0	-2.5	-2.5		-2.5	
11	0	1	0	1	1	-2.0	-2.0		-2.0	
12	0	1	1	0	0	-1.5	-1.5		-1.5	
13	0	1	1	0	1	-1.0	-1.0		-1.0	
14	0	1	1	1	0	-0.5	-0.5		-0.5	
15	0	1	1	1	1	0.0	0.0		0.0	
16	1	0	0	0	0	0.5	0.5		0.5	
17	1	0	0	0	1	1.0	1.0		1.0	
18	1	0	0	1	0	1.5	1.5		1.5	
19	1	0	0	1	1	2.0	2.0		2.0	
20	1	0	1	0	0	2.5	2.5		2.5	
21	1	0	1	0	1	3.0	3.0		3.0	
22	1	0	1	1	0	3.5	3.5		3.5	
23	1	0	1	1	1	4.0	4.0		4.0	
24	1	1	0	0	0	4.5	4.5		4.5	
25	1	1	0	0	1	5.0	5.0		5.0	
26	1	1	0	1	0	5.5	5.5		5.5	
27	1	1	0	1	1	6.0	6.0		6.0	
28	1	1	1	0	0	6.5	6.5		6.5	
29	1	1	1	0	1	7.0	7.0		7.0	
30	1	1	1	1	0	7.5	7.5		7.5	
31	1	1	1	1	1	8.0	8.0		8.0	

Note: Each setting value is determined in relation to the initial setting value.

Returns to initial value at reset ( ——— parts)

EV2 data bits D<sub>4</sub>, D<sub>3</sub> are \*.

Table 2 Volume Gain Deviation

Volume control No.	Condition	Min.	Typ.	Max.	Unit
EV0 EV1 EV3	Gain deviation, with respect to reference value shown in Table1	Reference value - 0.5 dB	Reference value	Reference value + 0.5 dB	dB
EV2	Input frequency = 1020 Hz Input level = - 20 dBv	Reference value - 1.0 dB	Reference value	Reference value + 1.0 dB	

# MB86435

## (5) Tone Generator Circuit

### • Tone Frequency Control Registers

The tone generator uses a clock signal obtained by subdividing the TCLK clock signal input by 1/1, 1/2 or 1/4 according to the data bit in address 1110.

**Table 3 Tone Clock Frequency Register Control**

Address 1110		Tone generator clock signal ( $f_{IN}$ )
D <sub>4</sub>	D <sub>3</sub>	
0	0	TCLK input clock signal
0	1	TCLK input clock signal subdivided by 1/2
1	0	TCLK input clock signal subdivided by 1/4
1	1	Prohibited

Frequency settings available through the tone frequency control register are determined by the following formula. Frequency setting  $f = f_{IN}/(12*(1+n))$ ,  $n=1, 2, 3, \dots, 255$ . (where  $f_{IN}$ : tone generator clock signal frequency).

Therefore the available frequency setting range when  $f_{IN} = 512$  kHz is between  $f_{min} = 167$  Hz and  $f_{max} = 21333$  Hz.

Frequency settings corresponding to each DTMF rated reference frequency are shown in the following table.

**Table 4 Tone Frequency Register Control**

(Condition: 512 kHz)

Tone type	Rated reference frequency (generator frequency)	Frequency setting	Address 1010/1100					Address 1011/1101					n	Error	
			D <sub>4</sub>	D <sub>3</sub>	D <sub>2</sub>	D <sub>1</sub>	D <sub>0</sub>	D <sub>4</sub>	D <sub>3</sub>	D <sub>2</sub>	D <sub>1</sub>	D <sub>0</sub>			
Service tone (single tone)	262 Hz	261.7 Hz	—	1	0	1	0	*	0	0	1	0	162	-0.11%	
	384 Hz	384.4 Hz	—	0	1	1	0	*	1	1	1	0	110	0.10%	
	400 Hz	398.7 Hz	—	0	1	1	0	*	1	0	1	0	106	-0.32%	
	2000 Hz	2031.7 Hz	—	0	0	0	1	*	0	1	0	0	20	1.56%	
	2600 Hz	2666.7 Hz	—	0	0	0	0	*	1	1	1	1	15	2.50%	
DTMF	Low tone	697 Hz	699.4 Hz	—	0	0	1	1	*	1	1	0	0	60	0.34%
		770 Hz	775.7 Hz	—	0	0	1	1	*	0	1	1	0	54	0.74%
		852 Hz	853.3 Hz	—	0	0	1	1	*	0	0	0	1	49	0.15%
		941 Hz	948.1 Hz	—	0	0	1	0	*	1	1	0	0	44	0.75%
	High tone	1209 Hz	1219.0 Hz	—	0	0	1	0	*	0	0	1	0	34	0.82%
		1336 Hz	1333.3 Hz	—	0	0	0	1	*	1	1	1	1	31	-0.20%
		1477 Hz	1471.3 Hz	—	0	0	0	1	*	1	1	0	0	28	-0.38%
		1633 Hz	1641.0 Hz	—	0	0	0	1	*	1	0	0	1	25	0.48%

Note: • Setting values are BIN display values

• Error represents frequency setting error with respect to rated reference frequency.

# MB86435

### • Tone Output Waveform

The D4 data bit at address 1010, 1100 may be used to select either sine-wave or trapezoidal waveforms for tone output.

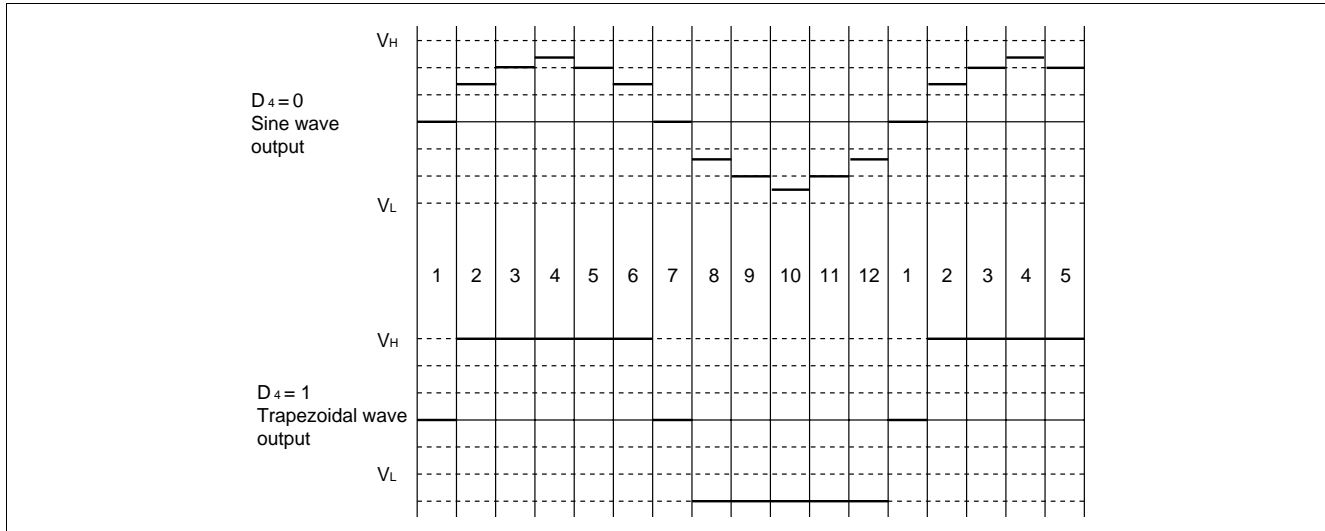

### • Tone Output Control

Tone output may be controlled by address and through the external tone control input pin TONC. In addition, the tone control offers a choice of sine or trapezoidal waveforms.

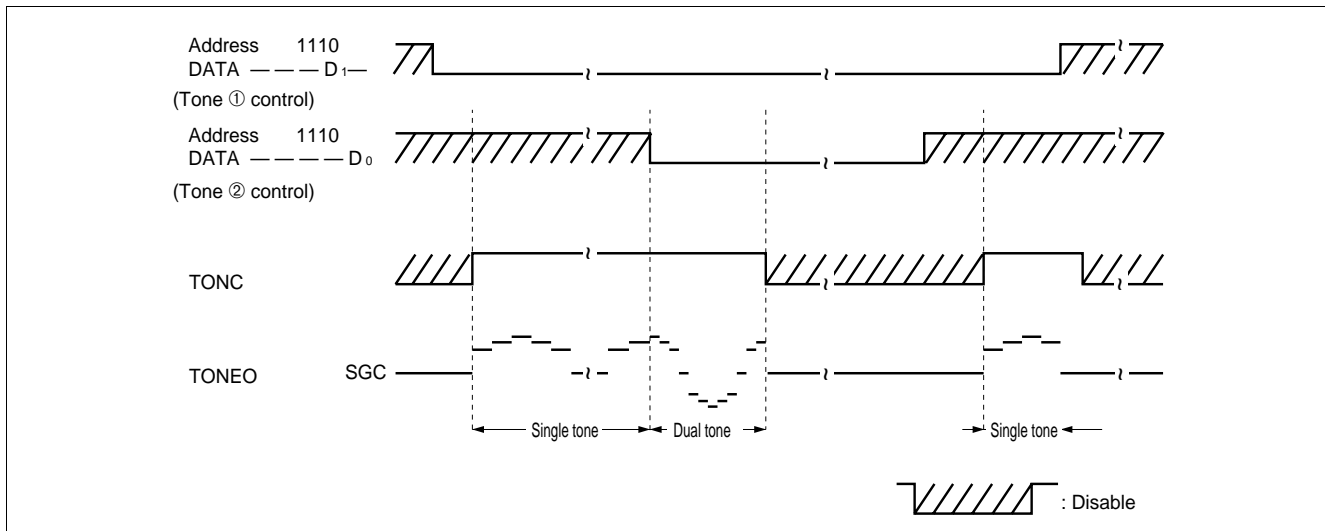

### • LED Output Controls

Output from the LED output pins can be controlled by the TONC signal and the address 1110 data bit D2. When the TONC signal is H-level, and the address 1110 data bit D2 value is L-level, the output level will be high. Output levels are CMOS levels.

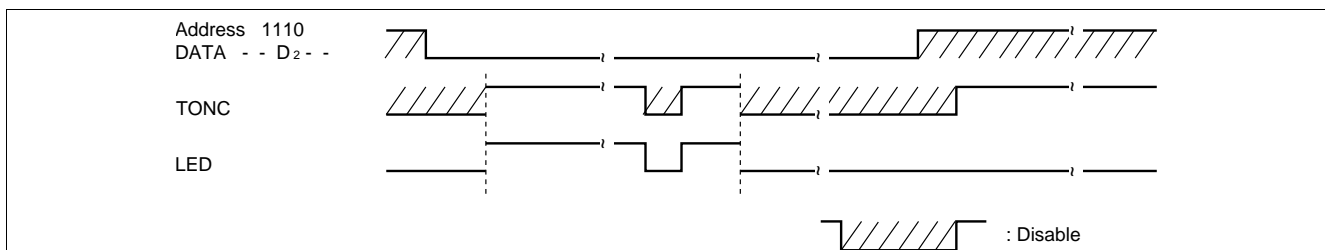

# MB86435

## • Tone Generator Control Output Level

(Condition: EV3 = 0 dB)

External pins				Address 1110 data bits			Address 0111 data bits	Tone generator circuit operating mode		Output pin mode		Remarks
PSC2	PSC1	PSC0	TONC	D <sub>2</sub>	D <sub>1</sub>	D <sub>0</sub>	D <sub>3</sub> (SW2)	Tone (1)	Tone (2)	LED	TONEO	
0	0	0	—	—	—	—	—	×	×	L	H-Z	
1	0	0	—	—	—	—	—	×	×	L	H-Z	
—	1 or 1		0	—	—	—	0	SGC	SGC	L	SGC	
—	1 or 1		0	—	—	—	1	SGC	SGC	L	H-Z	
—	1 or 1		1	1	—	—	—	—	—	L	—	
—	1 or 1		1	0	—	—	—	—	—	○	—	
—	1 or 1		1	—	1	1	0	SGC	SGC	—	SGC	
—	1 or 1		1	—	1	0	0	SGC	○	—	-14 dBv	Single tone output
—	1 or 1		1	—	0	1	0	○	SGC	—	-14 dBv	Single tone output
—	1 or 1		1	—	0	0	0	○	○	—	-14 dBv	Dual tone output

○ : Operational, × : Power down, H-Z : High-impedance, L: L-level fixed, SGC: SGC fixed

Note: When the TONC pin signal is L-level, the tone generator circuit counters will be reset. When a dual tone is generated at the time of reset, the initial phase settings for tone (1) and tone (2) will be in phase.

## • Example: When Tone (1), Tone (2) are at the same frequency:

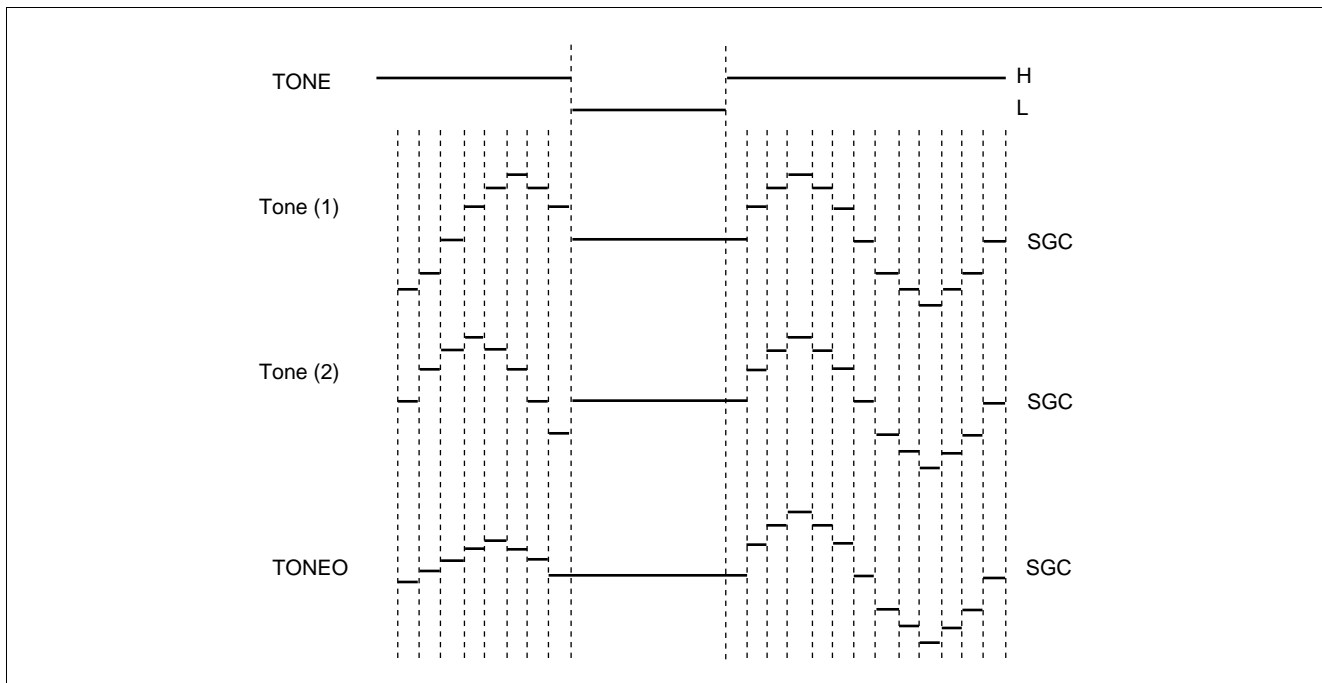

# MB86435

## (6) Codec Input/Output

Both the  $\mu$ -law and A-law coding/decoding conversion processes used by the MB86435 codec are compatible with CCITT Recommendation G.711. In addition, linear coding in the form of 14-bit two's complement code can be output starting with MSB values.

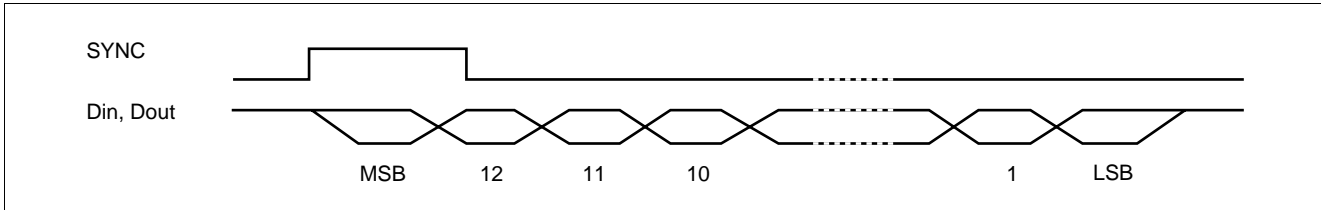

MSB	Code	LSB	PTBO reference voltage (V)
0	1 1 1 1 1 1 1 1 1 1 1 1 1 1	1	0.7354
	to		to
0	0 0 0 0 0 0 0 0 0 0 0 0 0 0	1	1.4991
0	0 0 0 0 0 0 0 0 0 0 0 0 0 0	0	1.5000
1	1 1 1 1 1 1 1 1 1 1 1 1 1 1	1	1.5009
	to		to
1	0 0 0 0 0 0 0 0 0 0 0 0 0 0	1	2.2647

## (7) The Codec SYNC Pin

The codec block requires the input of an 8 kHz sampling clock signal at the SYNC pin, as well as a data transfer clock at the CLK pin. In order to conserve power consumption, whenever the SYNC pin or CLK pin signal is inactive, the system goes into SYNC power-down mode and stops code conversion.

Also, if either the SYNC or CLK pins encounters jitter of 5  $\mu$ s or greater, the system may go into power-down mode. Table 1.10 shows the status of output pins in SYNC power-down mode.

Pin symbol	Operation
SGC	Normal operation (1.5 V)
SGO	Normal operation (1.5 V)
VRH	Normal operation (2.5 V)
DOUT	H-level fixed
PTBO	SGC
BTPO	High impedance

# MB86435

## (8) Parallel Output

The LO0 to 3 pins carry latched output for external controls. The data written to address 1000 can be output through these pins. Output is CMOS output.

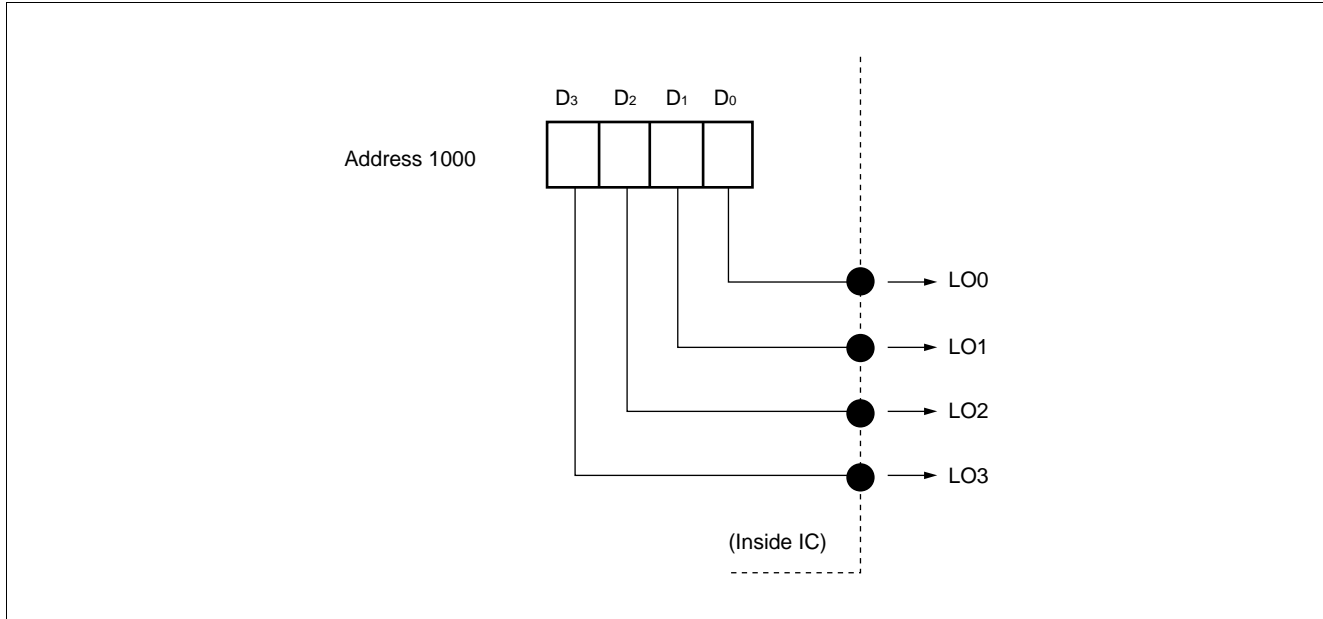

## 2. Analog Input

Analog input signals in the MB86435 include the two microphone inputs and the three accessory input.

### (1) Microphone Amps

The microphone amps take the incoming signal from the microphones and amplify it to any desired level of gain. The microphone lines are low-noise types for use with piezoelectric-ceramic or capacitor microphones, and are capable of a wide range of amplification. All microphones and amps must be coupled with capacitors to prevent amplification of offset signals.

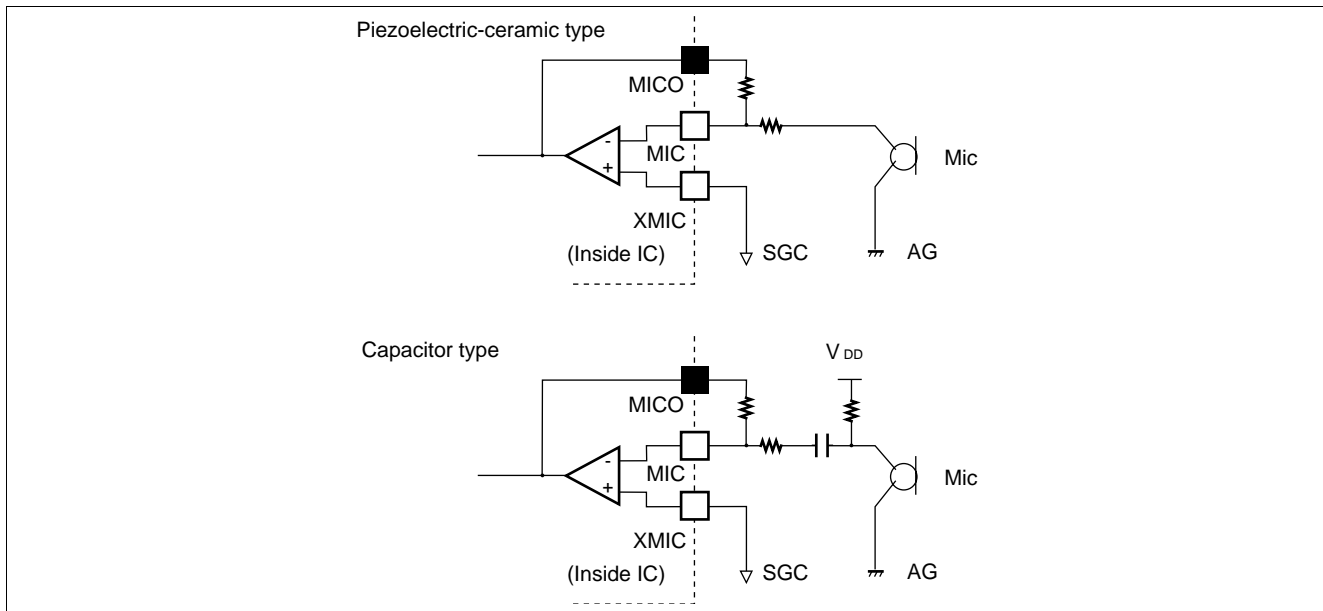



Table 5 Microphone Amp Characteristics

Parameter	Characteristics (typ)
Gain measurement range	0 to 35 dB
Minimum load level	50 k $\Omega$
Maximum output level	0.75 V <sub>OP</sub>

## (2) Accessory Input

Direct input from the TAUD to the codec unit is possible through SW5, without passing through the microphone amp. Care must be taken with the input signal in this case, however, because input resistance is not at high-impedance level.

Microphone amp output may be added to the signal by using switching controls.

In this case, the result will be at the additional output level.

In addition, SW10 and SW11 may be used to transmit digital data from the TAUD to EXSD and DSCK, allowing the sending of fax or PC data without modification.

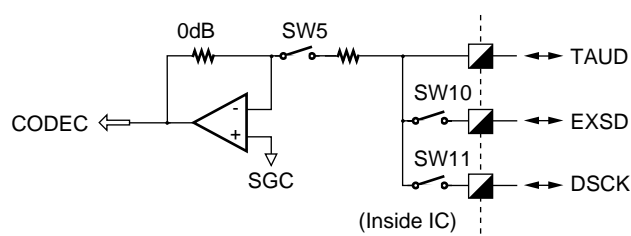

Note: TAUD, EXSD, and DSCK contain no digital buffers. If not used, TAUD, EXSD and DSCK should be connected to SGC.

## 3. Analog Output

The MB86435 has a total of four analog output circuits, including the three speaker drive circuits (receiver, earphone and tone) and the accessory output.

### (1) Speaker Drive Amp

The speaker drive amps include two circuits (receiver and tone) with BTL output and one system (earphone) with single output. Because the speaker amp requires relatively high levels of power, it is connected to speaker selection switches (sw6-sw9) for power-down mode selection.

Two systems (receiver and earphone) have fixed gain levels, while the other system (tone) allows gain adjustment by means of external resistors.

Table 6 Speaker Drive Amp Output Standards

Parameter	Receiver speaker amps (EAR, XEAR)	Earphone speaker amp (JEAR)	Tone speaker amps (TONE, XTONE)
Output type	BTL	Single	BTL
Load resistance *1	32 $\Omega$ (typ)	32 $\Omega$ (typ)	25 $\Omega$ (typ)
Load resistance *2	2.8 k $\Omega$ (typ)	2.8 k $\Omega$ (typ)	2.8 k $\Omega$ (typ)
Load capacity *2	70 nF	70 nF	70 nF
Final stage gain	-4.3 dB (between EAR-XEAR)	-2.5 dB/-8.5 dB (JEAR)	-5 to 20 dB (between TONE-XTONE)
Maximum output power	6.4 mW (min)	2 mW (min)	10 mW (min)

\*1: Dynamic-type speaker

\*2: Piezoelectric-ceramic type speaker

# MB86435

• Analog Output Connection Example

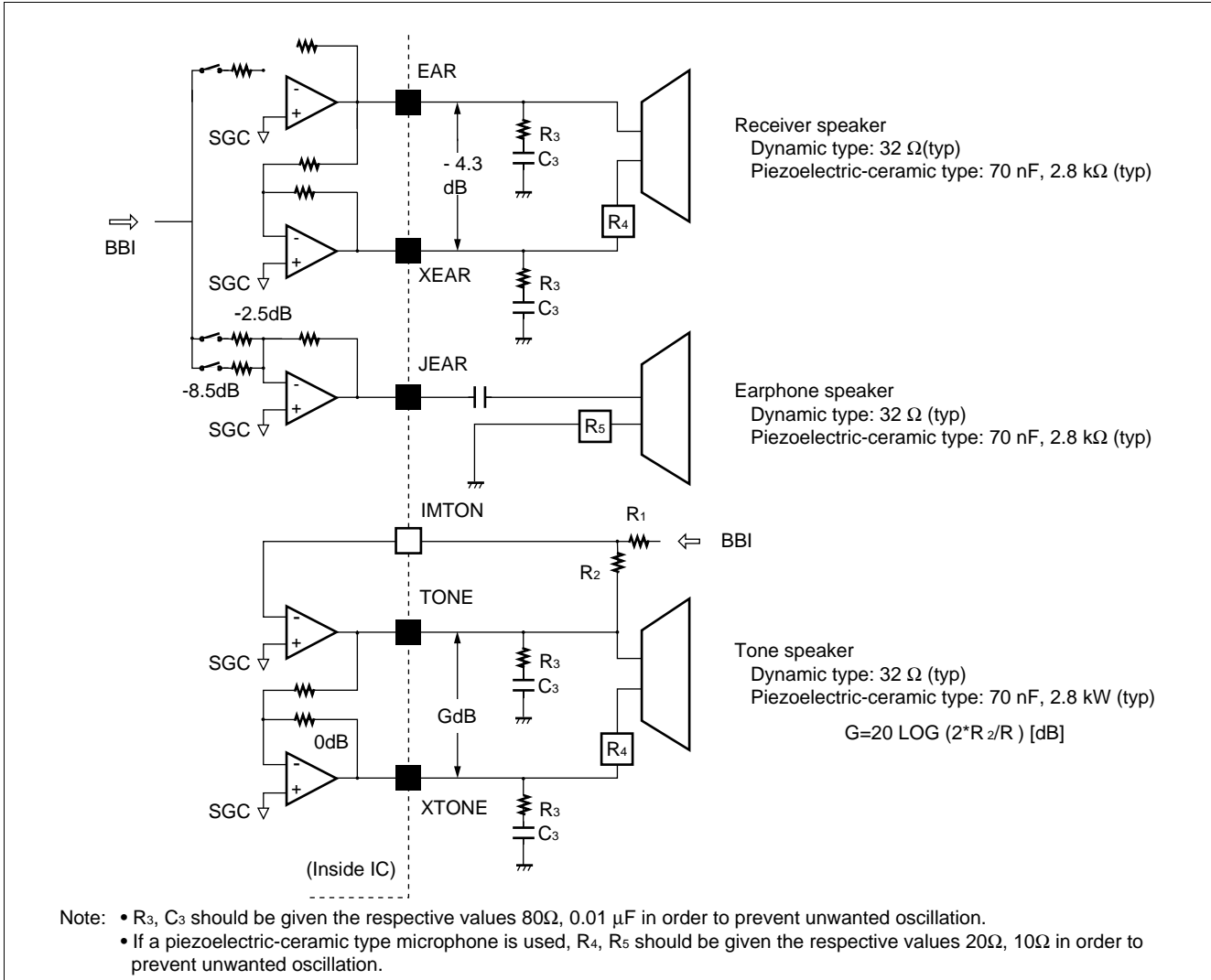

• Tone Speaker Amp Not Used

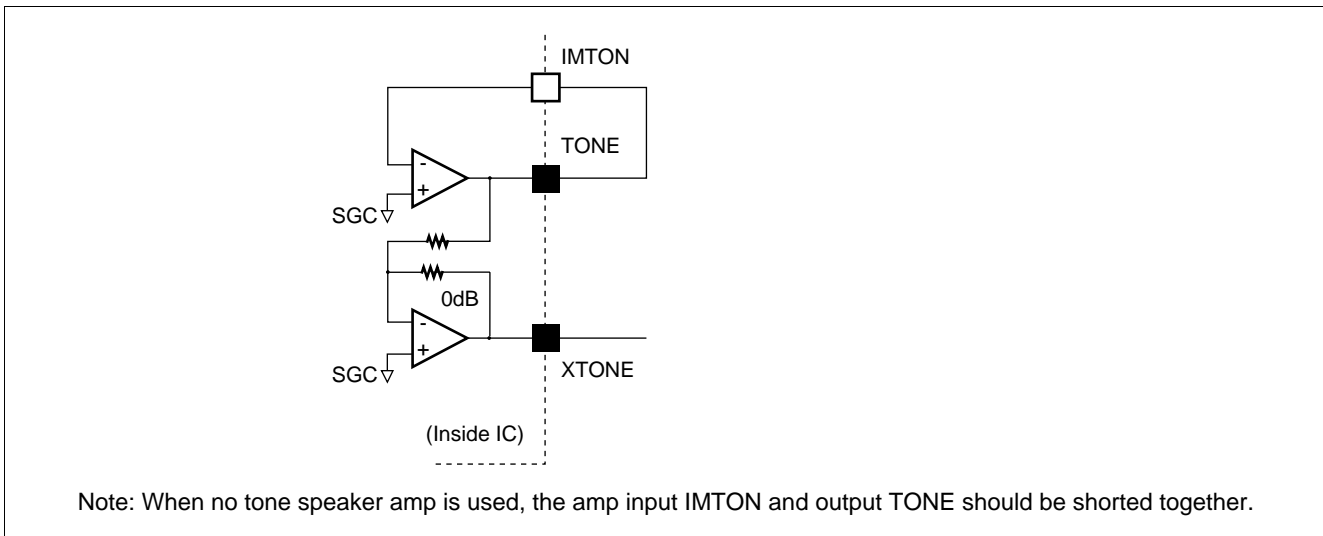

## MB86435

**(2) Accessory Output**

The accessory output (RAUD pin) can carry either digital or analog output signals, and is controlled by address 0101 data bit D<sub>4</sub> (SW 8), and address 0111 data bit D<sub>1</sub> (SW 12).

When both SW 8 and SW 12 are in off position, the accessory outputline is H-Z (high impedance) state. Caution: never place both SW 8 and SW 12 in on position at the same time. This may cause the MB86435 to function improperly.

- **SW12 in On Position**

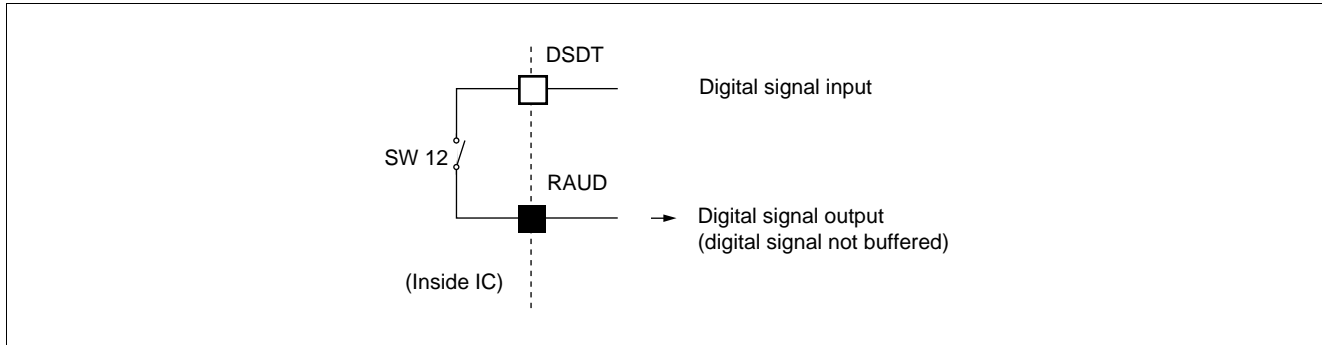

Address				Data bit				
A <sub>4</sub>	A <sub>3</sub>	A <sub>2</sub>	A <sub>1</sub>	D <sub>4</sub>	D <sub>3</sub>	D <sub>2</sub>	D <sub>1</sub>	D <sub>0</sub>
0	1	1	1	—	—	—	1	—

- **SW8 in On Position**

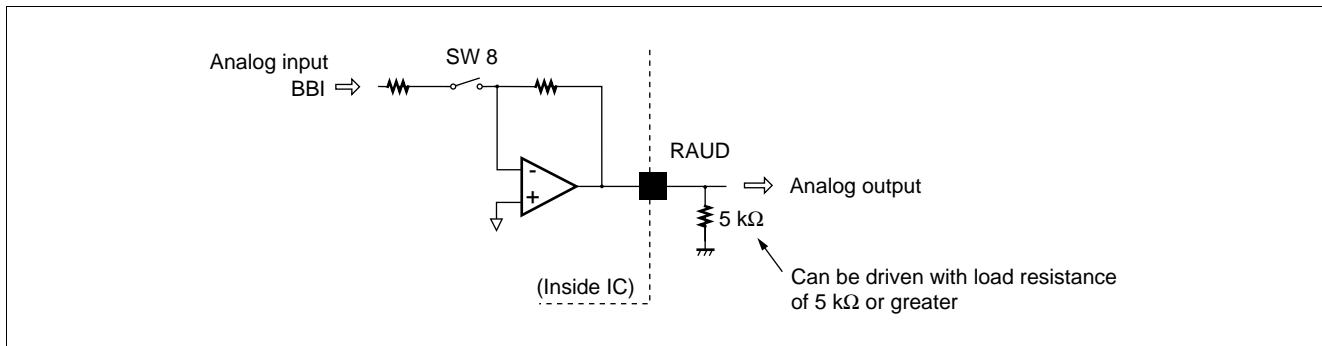

Address				Data bit				
A <sub>4</sub>	A <sub>3</sub>	A <sub>2</sub>	A <sub>1</sub>	D <sub>4</sub>	D <sub>3</sub>	D <sub>2</sub>	D <sub>1</sub>	D <sub>0</sub>
0	1	0	0	0	*	*	*	—
0	1	0	1	0	*	—	—	—

# MB86435

## 4. Receiver Connections

It is possible to add tones and adjust sidetones by using amp 1,2 and 3 and the electronic volume control. When using amp 3, however, it is necessary to include HPF to avoid interference from the speaker amp DC.

- **Tone and Sidetone Addition by Inclusion of Secondary LPF and Primary HPF.**

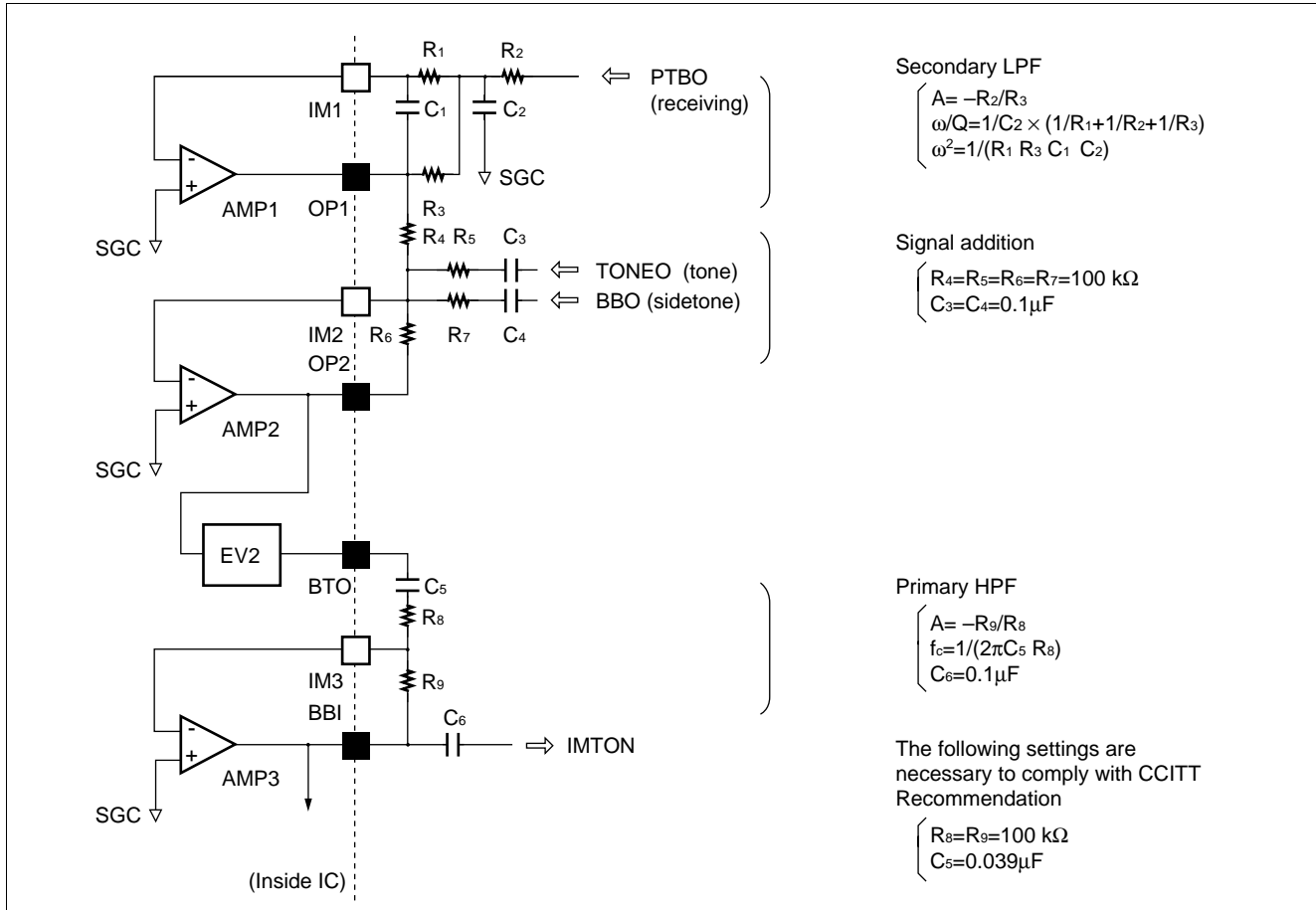

- **Amp1, Amp2 not used**

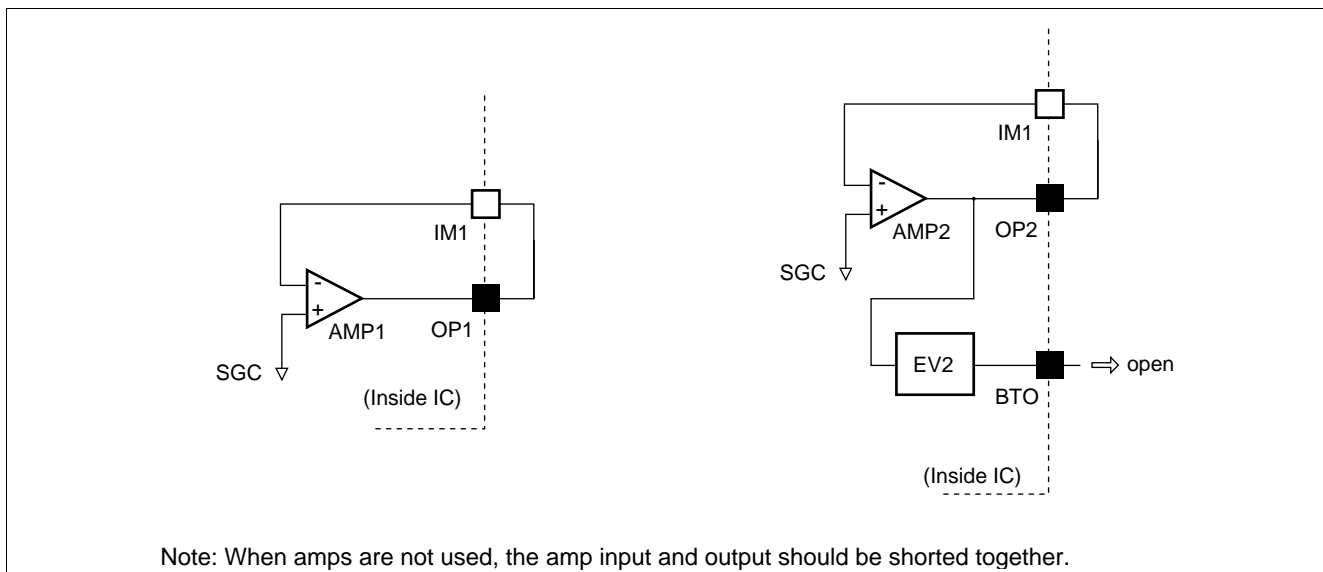

# MB86435

• Tone and Sidetone Addition by Inclusion of Third-Order HPF

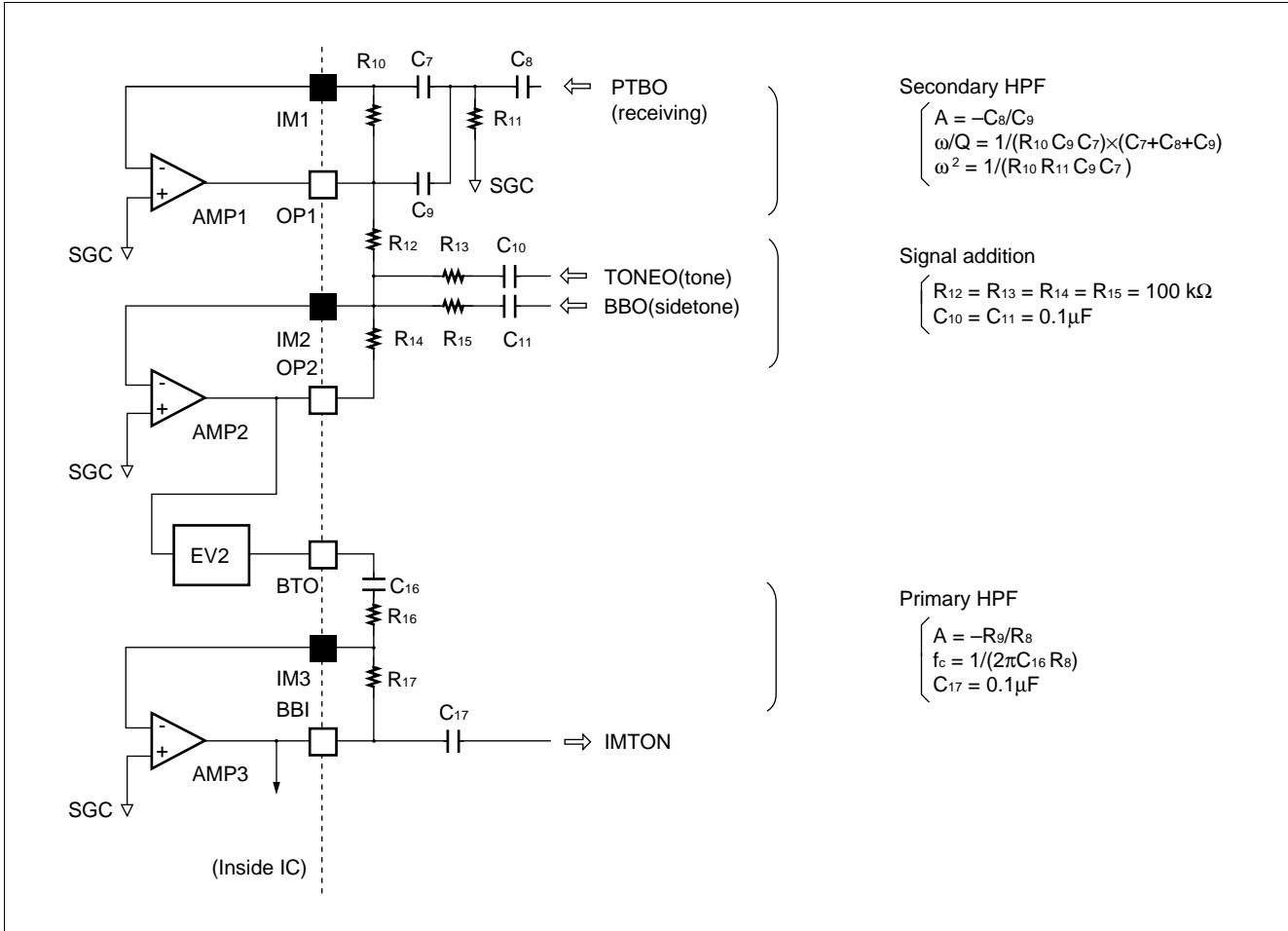

# MB86435

## 5. Power Saving Modes

### (1) Mode Selection

The MB86435 power saving modes can be controlled by using the external control signal lines (3 lines). It is also possible to apply power saving modes to the speaker amps with high power consumption levels by writing changes to register settings. Whenever the MB86435 changes directly from a power-down mode to normal operating mode, there is a possibility that speaker tones may be produced. The recommended sequence of coding changes to go into normal mode is (VREF mode) → (Tone mode) → (Normal mode).

### Power Saving Modes

Mode	External pins			Ad-dress		Address 0110				Output pin status										Operating circuit status						Power supply current (mA) (typ)							
	PS C2	PS C1	PS C0	D4	D0	D	D	D	D	EAR XEAR	JEAR	TONE XTONE	RAUD	DOUT	SGC SGO	OP2 BTO	PTBO BTPO	OP1	MICO BBO JMICO VRH	BBI	CODEC	VREF generator	TONE generator	Sending	Receiving		Receiving	Earphone	Tone	Accessory			
						SW8	SW7	SW9	SW6	SW6	SW7	SW9	SW8															SW6	SW7	SW9	SW8		
All Power-down	0	0	0	—	—	—	—	—	—	ZA	H-Z	ZB	H-Z	H	H-Z	ZC	H-Z	H-Z	H-Z	H-Z	*	×	×	×	×	×	×	×	×	×	×	0.0005	
VREF	1	0	0	—	—	—	—	—	—	ZA	H-Z	ZB	H-Z	H	○	ZC	H-Z	H-Z	H-Z	H-Z	*	×	○	×	×	×	×	×	×	×	×	0.41	
Tone	—	1	0	1	1	—	—	—	—	ZA	H-Z	ZB	H-Z	H	○	○	H-Z	H-Z	H-Z	H-Z	○	×	○	○	×	○	×	×	×	×	×	1.8	
	—	1	0	0	1	0	1	1	1	ZA	H-Z	ZB	○	H	○	○	H-Z	H-Z	H-Z	H-Z	○	×	○	○	×	○	×	×	×	○	×	2.4	
	—	1	0	0	1	1	0	1	1	ZA	○	ZB	H-Z	H	○	○	H-Z	H-Z	H-Z	H-Z	○	×	○	○	×	○	×	○	×	○	×	4.4	
	—	1	0	0	1	1	1	0	1	ZA	H-Z	○	H-Z	H	○	○	H-Z	H-Z	H-Z	H-Z	○	×	○	○	×	○	×	×	○	×	×	6.6	
	—	1	0	0	1	1	1	1	0	○	H-Z	ZB	H-Z	H	○	○	H-Z	H-Z	H-Z	H-Z	○	×	○	○	×	○	○	×	×	×	×	6.6	
Normal	—	—	1	0	0	0	1	1	1	ZA	H-Z	ZB	○	○	○	○	○	○	○	○	○	○	○	○	○	○	○	○	×	×	×	○	6.0
	—	—	1	0	0	1	0	1	1	ZA	○	ZB	H-Z	○	○	○	○	○	○	○	○	○	○	○	○	○	○	○	×	○	×	×	8.0
	—	—	1	0	0	1	1	0	1	ZA	H-Z	○	H-Z	○	○	○	○	○	○	○	○	○	○	○	○	○	○	○	×	×	○	×	10.2
	—	—	1	0	0	1	1	1	0	○	H-Z	ZB	H-Z	○	○	○	○	○	○	○	○	○	○	○	○	○	○	○	○	×	×	×	10.2
	—	—	1	0	0	0	0	0	0	○	○	○	○	○	○	○	○	○	○	○	○	○	○	○	○	○	○	○	○	○	○	○	18.2

Note: • ○ : Operational, ×: Power-down, H-Z: High impedance, H: H-level fixed

\* : High impedance may not be applied, depending on status of SW6, SW7, SW8.

ZA : EAR and XEAR are floating, however high resistance connection between EAR and XEAR.

ZB : TONE and XTONE are floating, however, high resistance connection between TONE and XTONE, and between SGO and XTONE.

ZC : Floating, however high resistance connection between OP2 and BTO. Codec in [Normal] mode operates with SYNC = 8 kHz, CLK = 2048 kHz.

• When RAUD is operating, address 0111 data bit D1 value should be "0" (SW12 off).

• In tone mode, address 0111 data bit D3 should be "0" (SW2 on), and address 0111 data bit D4 should be "0" (SW14 off).

• When the SYNC and CLK pin signals are fixed at either L-level or H-level, part of the codec unit will go into power-down mode. At this time the PTBO signal will be SGC level, BTPO will be H-Z, and VRH output will be approximately 4.0 V.

# MB86435

## ■ TIMING CHART

• Codec-Related Signals

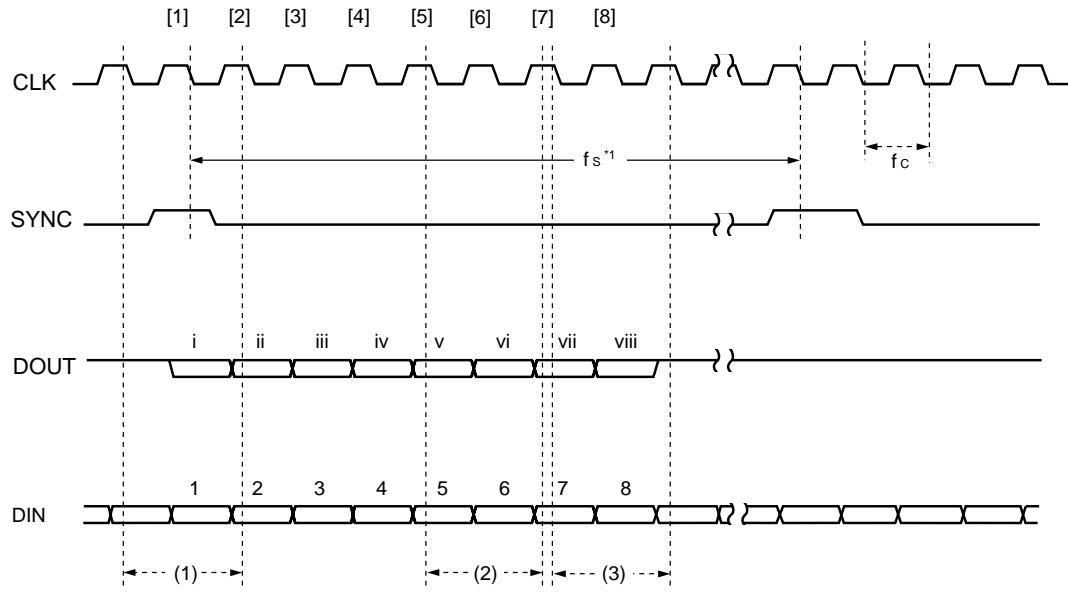

[Enlarged view]

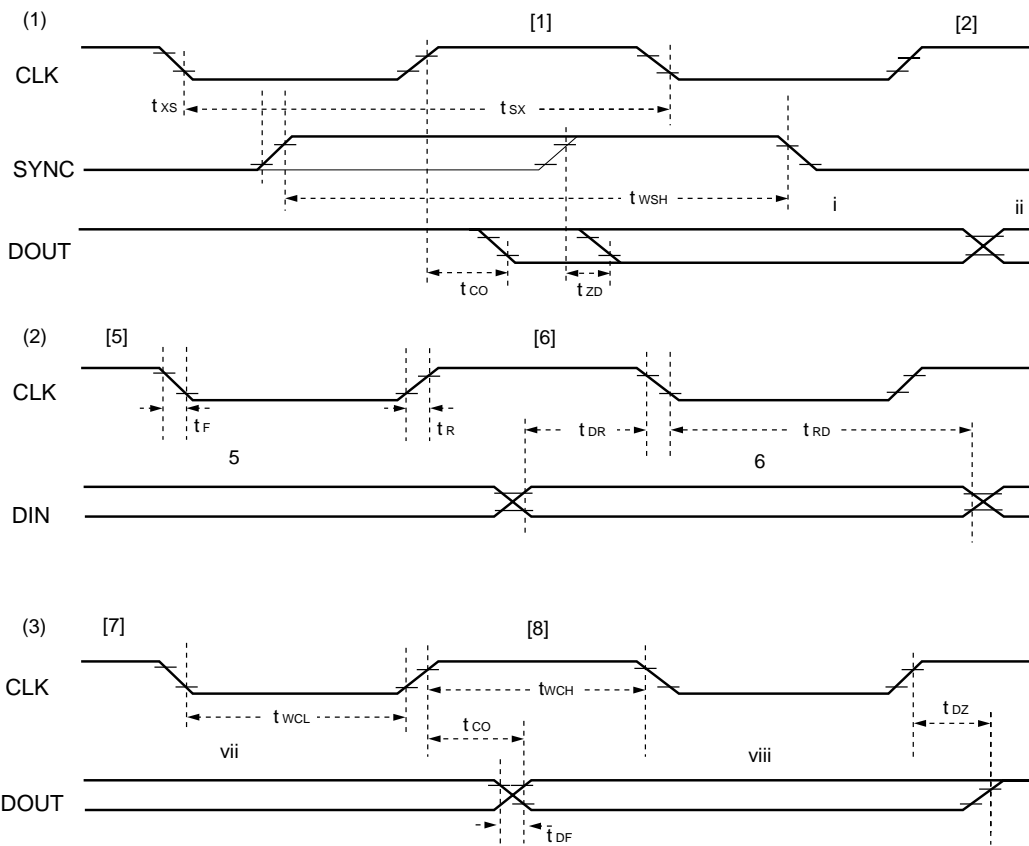

\*1 From first CLK Down to second CLK Down, SYNC = H.

# MB86435

• Microcomputer Data-Related Signals

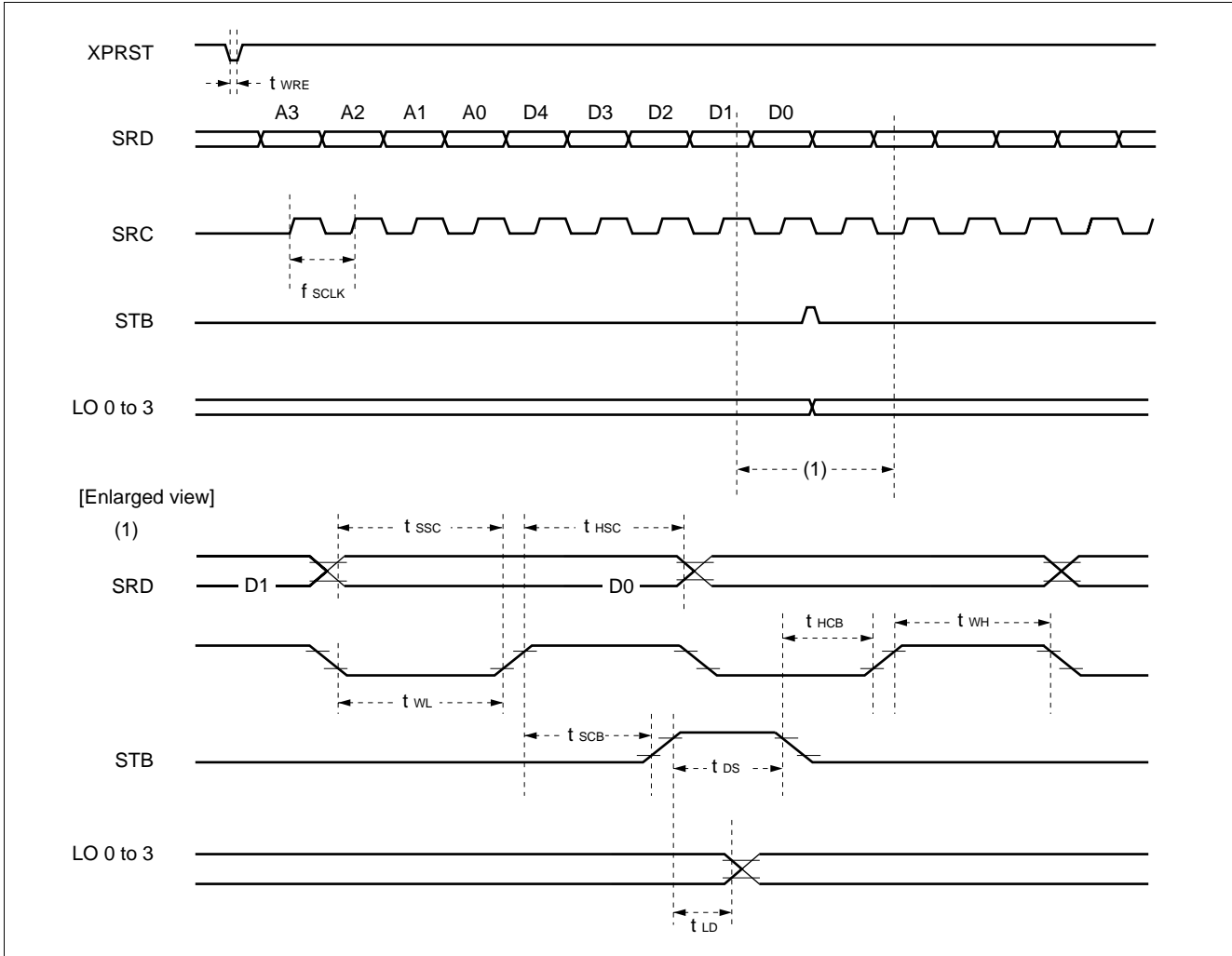



## MB86435

## ■ ABSOLUTE MAXIMUM RATINGS (See WARNING)

Parameter	Symbol	Rating		Unit
		Min.	Max.	
Power supply voltage	V <sub>S</sub>	-0.3	7.0	V
Analog input voltage	V <sub>AIN</sub>	-0.3	+V <sub>S</sub> + 0.3	V
Digital input voltage	V <sub>DIN</sub>	-0.3	+V <sub>S</sub> + 0.3	V
Storage temperature	V <sub>stg</sub>	-55	+125	°C

**WARNING:** Permanent device damage may occur if the above **Absolute Maximum Ratings** are exceeded. Functional operation should be restricted to the conditions as detailed in the operational sections of this data sheet. Exposure to absolute maximum rating conditions for extended periods may affect device reliability.

## ■ RECOMMENDED OPERATING CONDITIONS

Parameter	Symbol	Pin name	Value			Unit
			Min.	Typ.	Max.	
Operating temperature	T <sub>a</sub>	—	-20	+25	+80	°C
Power supply voltage	V <sub>S</sub>	VDD, VDDAB, VDDAC, VDDSP1, VDDSP2	2.7	3.0	3.6	V
Digital input voltage	V <sub>L</sub>	All digital input pins	0.0	—	V <sub>S</sub>	V
Analog output load resistance	R <sub>LB</sub>	BBO, PTBO, TONEO, BTO, BTPO	75	—	—	kΩ
Analog output load capacity	C <sub>LB</sub>		—	—	20	pF
Analog output load resistance* <sup>1</sup>	R <sub>LE</sub>	Between EAR-XEAR	—	32	—	Ω
Analog output load capacity* <sup>2</sup>	C <sub>LE</sub>		—	—	70	nF
Analog output load resistance* <sup>1</sup>	R <sub>LJ</sub>	JEAR	—	32	—	Ω
Analog output load capacity* <sup>2</sup>	C <sub>LJ</sub>		—	—	70	nF
Analog output load resistance* <sup>1</sup>	R <sub>LT</sub>	Between TONE-XTONE	—	25	—	Ω
Analog output load capacity* <sup>2</sup>	C <sub>LT</sub>		—	—	70	nF
Analog output load resistance	R <sub>LM</sub>	MICO, JMICO, SGO, BBI, OP1, OP2	50	—	—	kΩ
Analog output load capacity	C <sub>LM</sub>		—	—	20	pF
Analog output load resistance* <sup>3</sup>	R <sub>LM</sub>	RAUD	5	—	—	kΩ
Analog output load capacity* <sup>3</sup>	C <sub>LM</sub>		—	—	20	pF
Analog output voltage	V <sub>AOUT</sub>	All analog output pins	0.45	—	V <sub>DD</sub> -0.45	V
Analog input voltage	V <sub>AIN</sub>	All analog input pins	1.2	—	1.8	V

\*1: Dynamic typ speakers

\*2: Piezoelectric type speakers

\*3: When SW8 = on, SW12 = off

# MB86435

## ■ ELECTRICAL CHARACTERISTICS

### 1. DC Characteristics

Parameter		Symbol	Pin	Conditions	Value			Unit
					Min.	Typ.	Max.	
Power supply current at full power-down mode		$I_{VSS1}$	All $V_{DD}$ pins	PSC0 = 0 : PSC1 = 0 : PSC2 = 0, Ain = AG, Din = L	—	0.5	50	$\mu$ A
Power supply current with VREF operating		$I_{VSS2}$		PSC0 = 0 : PSC1 = 0 : PSC2 = 1, Ain = SGC, Din = L	—	410	800	$\mu$ A
Power supply current with TONE operating		$I_{VSS3}$		PSC0 = 0 : PSC1 = 1, Ain = SGC, Din = ICN SW6 = SW7 = SW8 = SW9 = off	—	1.8	3.0	mA
Power supply current for normal operation (only speaker ampmute)		$I_{VSS4}$		PSC0 = 1, Ain = SGC, Din = ICN SW6 = SW7 = SW9 = off	—	6.0	8.5	mA
Speaker amp power supply voltage	Receiver amps EAR, XEAR	$I_{VSS5}$	All $V_{DD}$ pins	PSC0 = 0, PSC1 = 1, Ain = SGC, Din = ICN, Power supply current differential when SW6 is on/off.	—	4.8	7.0	mA
	Earphone amp JEAR	$I_{VSS6}$		PSC0 = 0, PSC1 = 1, Ain = SGC, Din = ICN, Power supply current differential when SW7 is on/off.	—	2.6	4.0	mA
	Tone amps TONE, XTONE	$I_{VSS8}$		PSC0 = 0, PSC1 = 1, Ain = SGC, Din = ICN, Power supply current differential when SW9 is on/off.	—	4.8	7.0	mA
Digital input voltage		$V_{IH}$	All digital input pins	—	$V_s \times 0.7$	—	$V_s$	V
		$V_{IL}$		—	0	—	$V_s \times 0.3$	V
Digital input current		$I_{IH}$		—	—	—	10	$\mu$ A
		$I_{IL}$		—	—	—	10	$\mu$ A
Input offset voltage		$V_{FM}$	Between MIC-XMIC, between JMIC-XJMIC	—	-10	—	10	mA

(Continued)

## MB86435

(Continued)

Parameter	Symbol	Pin	Conditions	Value			Unit
				Min.	Typ.	Max.	
Output offset voltage	V <sub>FR</sub>	RAUD	BBI = SGC SW8 = on, SW6 = SW7 = SW9 = SW12 = off	-15	—	15	mV
	V <sub>FE</sub>	Between EAR-XEAR	BBI = SGC SW6 = on, SW7 = SW8 = SW9 = SW12 = off	-20	—	20	mV
	V <sub>FT</sub>	Between TONE-XTONE	IMTON = SGC SW9 = on, SW6 = SW7 = SW8 = SW12 = off	-20	—	20	mV
	V <sub>FP</sub>	PTBO	Din = ICN, EV2 = 0 dB	-100	—	100	mV
	V <sub>OH</sub>	Between MIC0-BBO	EV0 = 0 dB	-100	—	100	mV
	V <sub>OL</sub>	Between JMICO-BBO					
SGC output voltage	V <sub>SGC</sub>	SGC	—	1.40	1.50	1.60	V
SGO output voltage	V <sub>SGO</sub>	SGO	—	1.40	1.50	1.60	V
VRH output voltage	V <sub>VRH</sub>	VRH	—	—	2.5	—	V
Digital output voltage	V <sub>OH</sub>	All digital output pins	I <sub>OH</sub> = -0.5 mA	V <sub>S</sub> ×0.8	—	V <sub>S</sub>	V
Digital output voltage	V <sub>OL</sub>	All digital output pins	I <sub>OL</sub> = 0.5 mA	0.0	—	V <sub>S</sub> ×0.2	V
Resistance between pins TAUD and DSCK	R <sub>DR</sub>	Between DSTD-RAUD	SW12 = on, SW8 = off	—	—	2	kΩ
Resistance between pins TAUD and EXSD	R <sub>TE</sub>	Between TAUD-EXSD	SW10 = on, SW11 = off	—	—	2	kΩ
Resistance between pins DSTD and RAUD	R <sub>DE</sub>	Between TAUD-DSCK	SW11 = on, SW10 = off	—	—	2	kΩ

Note: Measurement conditions: ■ Standard Test Circuit

# MB86435

## 2. AC Characteristics

### (1) Codec-Related Signals

Parameter	Symbol	Conditions	Value			Unit
			Min.	Typ.	Max.	
Digital input rise time	$t_R$	$V_S \times 0.3 \rightarrow V_S \times 0.7$	—	—	50	ns
Digital input fall time	$t_F$		—	—	50	ns
Shift clock frequency	$f_C$	$\mu$ -law , A-law	64	—	3152	kHz
		Linear	256	—	3152	kHz
Shift clock pulse width (H)	$t_{WCH}$	$V_{IH} = V_S \times 0.7$	$1/f_C \times 0.3$	—	$1/f_C \times 0.7$	ns
Shift clock pulse width (L)	$t_{WCL}$	$V_{IL} = V_S \times -0.3$	$1/f_C \times 0.3$	—	$1/f_C \times 0.3$	ns
Sync frequency	$f_S$	—	—	8	—	kHz
Sync pulse width	$t_{WSH}$	—	$1/f_C$	—	62	$\mu$ s
SYNC to CLK setup time	$t_{SX}$	—	100	—	—	ns
CLK to SYNC hold time	$t_{XS}$	—	50	—	—	ns
CLK to DIN hold time	$t_{RD}$	—	50	—	—	ns
DIN to CLK setup time	$t_{DR}$	—	50	—	—	ns
SYNC to DOUT delay time	$t_{ZD}$	BIT 1	—	—	200	ns
CLK to DOUT delay time	$t_{CO}$	BIT 2 to 8	—	—	200	ns
CLK to DOUT disable time	$t_{DZ}$	"H"	—	—	200	ns
DOUT fall time	$t_{DF}$	—	10	—	100	ns

### (2) Microcomputer Data-Related Signals

Parameter	Symbol	Pin	Value			Unit
			Min.	Typ.	Max.	
SRC to SRD data setup time	$t_{SSC}$	SRD, SRC	50	—	—	ns
SRC to SRD data hold time	$t_{HSC}$		50	—	—	ns
SRC to STB setup time	$t_{SCB}$	SRC, STB	50	—	—	ns
SRC pulse width (H)	$t_{WH}$	SRC	200	—	—	ns
SRC pulse width (L)	$t_{WL}$		200	—	—	ns
STB pulse width	$t_{DS}$	STB	50	—	—	ns
STB to SRC hold time	$t_{HCB}$	STB, SRC	50	—	—	ns
LO0 to 3 delay time	$t_{LD}$	LO0 to 3	—	—	200	ns
Shift clock frequency	$f_{SCLK}$	SRC	—	—	2048	kHz
Reset pulse width	$t_{WRE}$	XPRST	1	—	—	$\mu$ s

## MB86435

## 3. Transmission Characteristics

## (1) Microphone Amp System

Parameter	Symbol	Conditions	Value			Unit
			Min.	Typ.	Max.	
Gain (between MIC0 and BBO)	$G_{MB}$	MICO = -20 dBv, 1020 Hz SW3 = on, SW4 = SW5 = SW14 = off EV 0 = 0 dB	-1.5	—	1.5	dB
Gain (between JMICO and BBO)	$G_{JB}$	JMICO = -20 dBv, 1020 Hz SW4 = on, SW3 = SW5 = SW14 = off EV 0 = 0 dB	-1.5	—	1.5	dB
Signal to noise ratio (between MIC and BBO) (between XMIC and BBO)	$S_{MB}$	Ain1 = -40 dBv ( +20 dBgain) SW3 = on, SW4 = SW5 = SW14 = off EV0 = 0 dB, 1020 Hz C message	40	—	—	dB
Signal to noise ratio (between JMICO and BBO) (between XJMICO and BBO)	$S_{JB}$	Ain2 = -40 dBv ( +20 dBgain) SW4 = on, SW3 = SW5 = SW14 = off EV0 = 0 dB, 1020 Hz C message	40	—	—	dB

Note: Measurement conditions: ■ Standard Test Circuit

## (2) Speaker Amp System

Parameter	Symbol	Conditions	Value			Unit
			Min.	Typ.	Max.	
Gain (between EAR and XEAR)	$G_{BE}$	BBI = -20 dBv, 1020 Hz	—	-4.3	—	dB
Gain (between BBI and JEAR)	$G_{BJ}$	BBI = -20 dBv, 1020 Hz, ATT = -2.5 dB	—	-2.5	—	dB
	$G_{BJ6}$	BBI = -20 dBv, 1020 Hz, ATT = -8.5 dB	—	-8.5	—	dB
Gain (between BBI and RAUD)	$G_{BR}$	BBI = -20 dBv, 1020 Hz SW8 = on, SW6 = SW7 = SW12 = off	—	0.0	—	dB
Output power	$W_E$	R = 32 $\Omega$ , between EAR-XEAR THD = 10%	6.4	—	—	mW
	$W_T$	R = 25 $\Omega$ , between TONE-XTONE gain = 0 dB, THD = 10%	10.0	—	—	mW
	$W_J$	R = 32 $\Omega$ , JEAR, ATT = -2.5 dB THD = 10%	2.0	—	—	mW

Note: Measurement conditions: ■ Standard Test Circuit

## (3) TONE System

Parameter	Symbol	Conditions	Value			Unit
			Min.	Typ.	Max.	
TONE output level (TONE0)	$G_{T1}$	1 tone generated, SW2 = on $f_1 = 948.1$ kHz	—	-14.0	—	dBv
	$G_{T2}$	2 tone generated, SW2 = on $f_1 = 948.1$ kHz, $f_2 = 1219.1$ kHz	—	-14.0	—	dBv

Note: Measurement conditions: ■ Standard Test Circuit

# MB86435

## (4) Electric Volume System

Parameter	Symbol	Conditions	Value			Unit
			Min.	Typ.	Max.	
Volume gain error EV0 (between TAUD-BBO)	$G_{E0}$	SW5 = on, SW3 = SW4 = SW14 = off TAUD = -20 dBv, 1020 Hz	-0.7	—	0.7	dB
Volume gain error EV1 (between DIN-PTBO)	$G_{E1}$	$D_{IN} = -20$ dBm0, 1020 Hz	-0.8	—	0.8	dB
Volume gain error EV2 (between IM 2-BTO)	$S_{E2}$	IM2 = -20 dBv, 1020 Hz	-1.0	—	1.0	dB
Volume gain error EV3 (TONEO)	$S_{E3}$	SW2 = on 1 tone generated $f_1 = 948.1$ kHz	-0.5	—	0.5	dB

Note: Measurement conditions: ■ Standard test circuit

## (5) Sending/Receiving System (Codec, Analog Block)

Parameter	Symbol	Conditions	Value			Unit
			Min.	Typ.	Max.	
Crosstalk (send → receive)	CTX	$A_{in1} = 1020$ Hz, -40 dBv (20 dBgain) $D_{IN} = ICN$ Measured at RAUD pin	—	—	-50	dB
Crosstalk (send → receive)	CTR	$D_{IN} = 1020$ Hz, 0 dBm0 $A_{IN} = SGC$ Measured at DOUT pin	—	—	-50	dB
Power supply noise reduction ratio	PSRR	$0 < f < 50$ kHz, $V_{DD} + 30$ mV <sub>OP</sub> C message $A_{IN} = SGC$ , $D_{IN} = ICN$	—	22	—	dB

Note: Measurement conditions: ■ Standard test circuit

## MB86435

## (6) Codec

Parameter	Symbol	Conditions	Value			Unit	
			Min.	Typ.	Max.		
Gain tracking (A to D) BTPO → DOUT	GTX	1020 Hz, -10 dBm0 Reference value	+3 to -40 dBm0	-0.2	—	0.2	dB
			-40 to -50 dBm0	-0.4	—	0.4	dB
			-50 to -55 dBm0	-0.8	—	0.8	dB
Gain tracking (D to A) DIN → PTBO	GTR	1020 Hz, -10 dBm0 Reference value EV1 = 0 dB	+3 to -40 dBm0	-0.4	—	0.4	dB
			-40 to -50 dBm0	-0.6	—	0.6	dB
			-50 to -55 dBm0	-1.0	—	1.0	dB
Gain tracking (A to D) (Linear) BTPO → DOUT	GTXL	1020 Hz, AFST-3 dB Reference value	AFST to AFST-43 dB	-0.2	—	0.2	dB
			AFST-43 to AFST-53 dB	-0.4	—	0.4	dB
			AFST-53 to AFST-53 dB	-0.8	—	0.8	dB
Gain tracking (D to A) (Linear) DIN → PTBO	GTRL	1020 Hz, AFST-3 dB Reference value EV1 = 0 dB	AFSR to AFSR-43 dB	-0.4	—	0.4	dB
			AFSR-43 to AFSR-53 dB	-0.6	—	0.6	dB
			AFSR-53 to AFSR-53 dB	-1.0	—	1.0	dB
Sending frequency characteristics (A to D) BTPO → DOUT	FRX	0 dBm0 (Linear : AFST-3 dB) 1020 Hz Reference value	0 to 60 Hz	24.0	—	—	dB
			60 to 300 Hz	-0.20	—	—	dB
			300 to 3000 Hz	-0.20	—	0.20	dB
			3000 to 3400 Hz	-0.20	—	0.8	dB
			3400 to 4600 Hz	*	—	—	dB
			4600 to 12 kHz	32.0	—	—	dB
Receiving frequency characteristics (D to A) DIN → PTBO	FRR	0 dBm0 (Linear : AFSR-3 dB) 1020 Hz Reference value EV1 = 0 dB	0 to 300 Hz	-0.30	—	—	dB
			300 to 3000 Hz	-0.30	—	0.30	dB
			3000 to 3400 Hz	-0.30	—	1.10	dB
			3400 to 4600 Hz	*	—	—	dB
			4600 to 12 kHz	32.0	—	—	dB
Sending absolute gain (A to D) BTPO → DOUT	GAX	1020 Hz, 0 dBm0 (Linear : AFST-3 dB) EV1 = 0 dB, V <sub>s</sub> = 3.0 V, T <sub>a</sub> = +25°C	-1.0	0	-1.0	dB	
		Power supply variation	—	±0.02	—	dB	
		Temperature variation	—	±0.001	—	dB/°C	
Receiving absolute gain (D to A) DIN → PTBO	GAR	1020 Hz, 0 dBm0 (Linear : AFSR-3 dB) V <sub>s</sub> = 3.0 V, T <sub>a</sub> = +25°C	-1.20	0	1.20	dB	
		Power supply variation	—	±0.04	—	dB	
		Temperature variation	—	±0.002	—	dB/°C	
Absolute level	VABS	Over load level $\mu$ -Law = 3.17 dB A-Law = 3.14 dB	—	0.7647	—	V <sub>OP</sub>	

(Continued)

## MB86435

(Continued)

Parameter	Symbol	Conditions	Value			Unit	
			Min.	Typ.	Max.		
Sending signal to noise ratio BTPO → DOUT	SDX	1020 Hz C message (A to D)	0 to -30 dBm0	34.0	—	—	dB
			-40 dBm0	28.0	—	—	dB
			-45 dBm0	23.0	—	—	dB
Receiving signal to noise ratio DIN → DOUT	SDR	1020 Hz C message (D to A)	0 to -30 dBm0	34.0	—	—	dB
			-40 dBm0	28.0	—	—	dB
			-45 dBm0	23.0	—	—	dB
Sending signal to noise ratio BTPO → DOUT (Linear)	SDXL	1020 Hz C message (A to D)	AFST-3 to AFST-33 dB	34.0	—	—	dB
			AFST-43 dB	28.0	—	—	dB
			AFST-45 dB	23.0	—	—	dB
Receiving signal to noise ratio BTPO → DOUT (Linear)	SDRL	1020 Hz C message (D to A)	AFSR-3 to AFSR-33 dB	34.0	—	—	dB
			AFSR-43 dB	28.0	—	—	dB
			AFSR-45 dB	23.0	—	—	dB
Sending no-talk noise BTPO → DOUT	ICNX	C message (A to D)	—	-72	-68	dBm0C	
Receiving no-talk noise DIN → PTBO	ICNR	C message (D to A)	—	-72	-68	dBm0C	
Analog input level BTPO	AILU	1020 Hz, 0 dBm0, Ta = +25°C Vs = 3.0 V μ-law	0.3290	0.3739	0.4195	Vrms	
Analog output level PTBO	AOLU	1020 Hz, 0 dBm0, Ta = +25°C Vs = 3.0 V μ-law	0.3290	0.3739	0.4195	Vrms	
Analog input level BTPO	AILA	1020 Hz, 0 dBm0, Ta = +25°C Vs = 3.0 V A-law	0.3315	0.3767	0.4227	Vrms	
Analog output level PTBO	AOLA	1020 Hz, 0 dBm0, Ta = +25°C Vs = 3.0 V A-law	0.3315	0.3767	0.4227	Vrms	
Analog input fullscale level BTPO	AFST	Vs = 3.0 V, Ta = +25°C Linear	0.6729	0.7647	0.8581	VOP	
Analog output fullscale level PTBO	AFSR	Vs = 3.0 V, Ta = +25°C Linear	0.6729	0.7647	0.8581	VOP	
Overall absolute delay (BTPO → PTBO)	PDA	Fc ≥ 1544 kHz (DOUT-DIN short)	—	490	550	μs	
Single frequency noise (BTPO → PTBO)	SFNA	BTPO = SCG 0-4 kHz (DOUT-DIN short) 4.6-200 kHz	—	—	-70 -50	dBm0 dBm0	
Discrimination (BTPO → PTBO)	DISA	BTPO = 0 dBm0, 4.6-200 kHz (DOUT-DIN short)	30	—	—	dB	
In-band spurious response (BTPO → PTBO)	IBSA	Second and third harmonic, BTPO = 0 dBm0 700-1100 Hz (DOUT-DIN short)	43	—	—	dB	

$$*: 14.5 \times \left\{ 1 - \text{SIN} \frac{\pi (4000 - f)}{1200} \right\}$$



# MB86435

## STANDARD TEST CIRCUIT

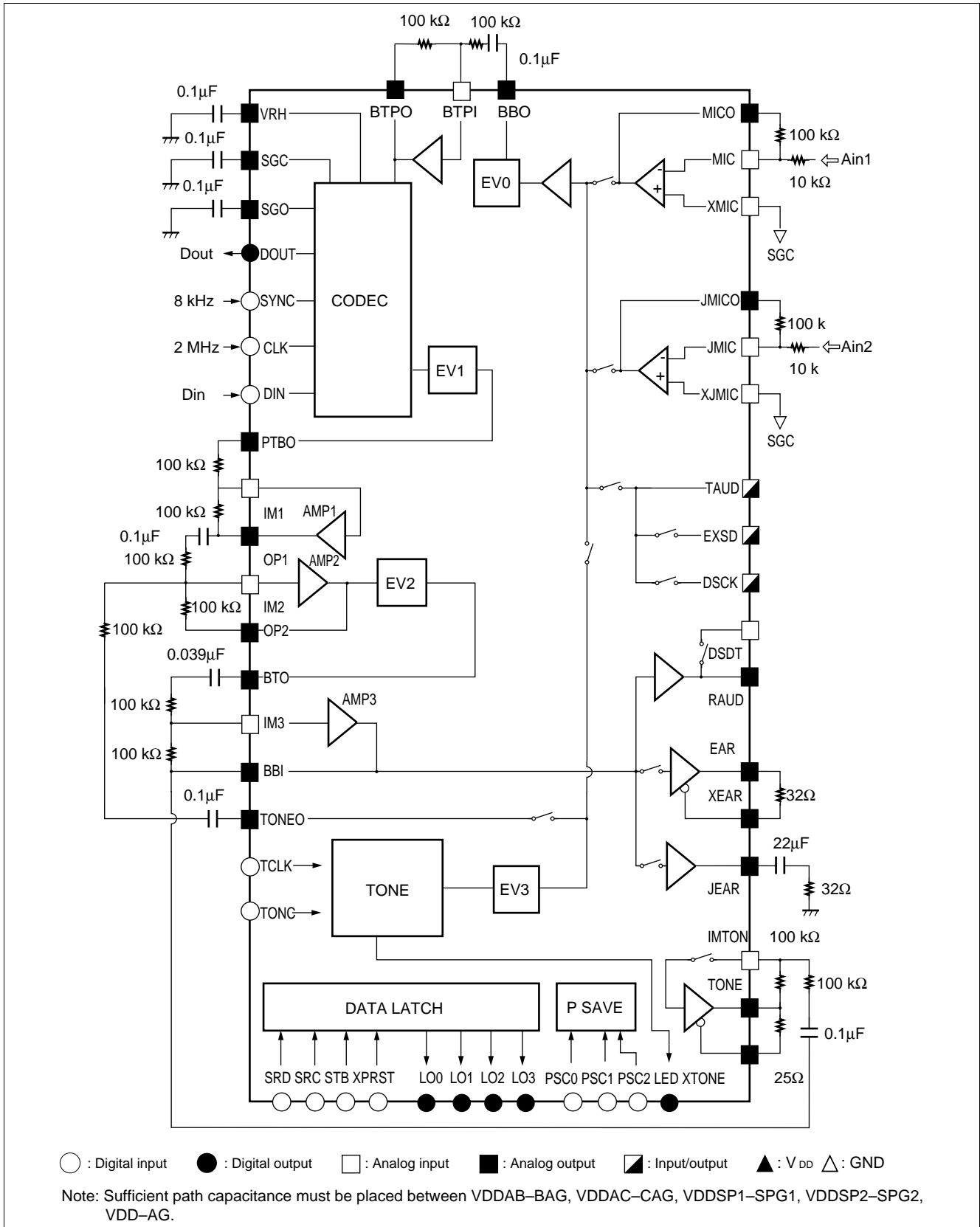

# MB86435

## ■ ORDERING INFORMATION

Part number	Package	Remarks
MB86435PFV	64 pins, Plastic LQFP (FPT-64P-M03)	

# MB86435

## ■ PACKAGE DIMENSION

64 pin Plastic LQFP  
(FPT-64P-M03)

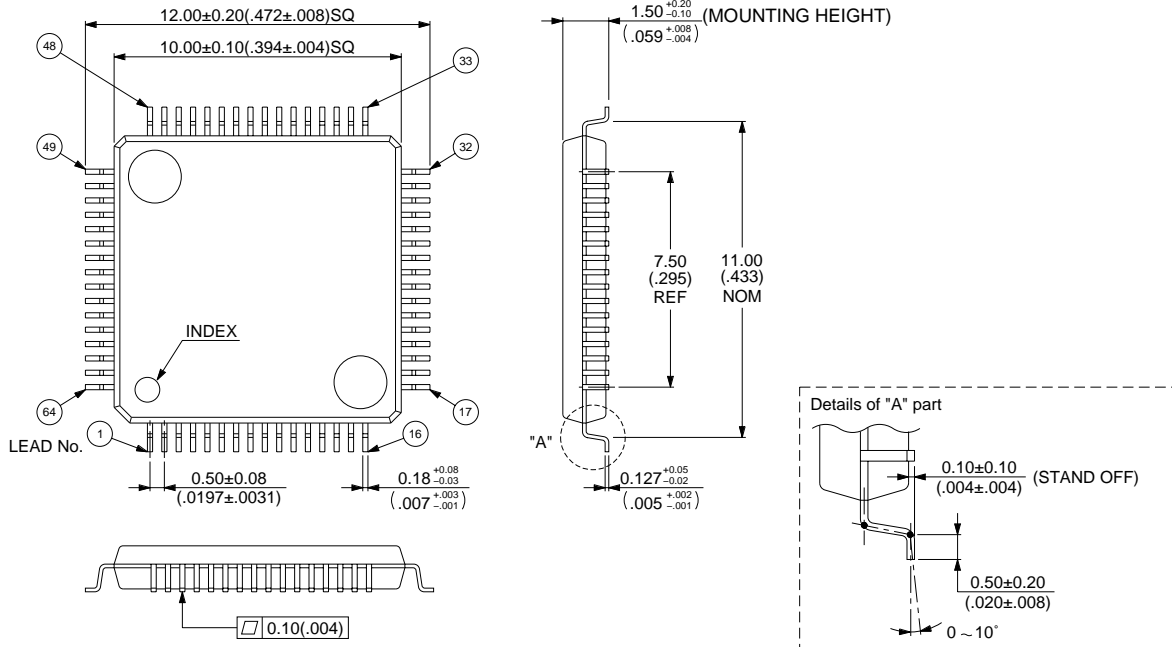

© 1995 FUJITSU LIMITED F64009S-2C-5

Dimensions in mm (inches).

# MB86435

## FUJITSU LIMITED

*For further information please contact:*

### **Japan**

FUJITSU LIMITED  
Corporate Global Business Support Division  
Electronic Devices  
KAWASAKI PLANT, 4-1-1, Kamikodanaka  
Nakahara-ku, Kawasaki-shi  
Kanagawa 211-8588, Japan  
Tel: (044) 754-3763  
Fax: (044) 754-3329

<http://www.fujitsu.co.jp/>

### **North and South America**

FUJITSU MICROELECTRONICS, INC.  
Semiconductor Division  
3545 North First Street  
San Jose, CA 95134-1804, USA  
Tel: (408) 922-9000  
Fax: (408) 922-9179

Customer Response Center  
*Mon. - Fri.: 7 am - 5 pm (PST)*  
Tel: (800) 866-8608  
Fax: (408) 922-9179

<http://www.fujitsumicro.com/>

### **Europe**

FUJITSU MIKROELEKTRONIK GmbH  
Am Siebenstein 6-10  
D-63303 Dreieich-Buchsschlag  
Germany  
Tel: (06103) 690-0  
Fax: (06103) 690-122

<http://www.fujitsu-edc.com/>

### **Asia Pacific**

FUJITSU MICROELECTRONICS ASIA PTE LTD  
#05-08, 151 Lorong Chuan  
New Tech Park  
Singapore 556741  
Tel: (65) 281-0770  
Fax: (65) 281-0220

<http://www.fmap.com.sg/>

F9803

© FUJITSU LIMITED Printed in Japan

All Rights Reserved.

The contents of this document are subject to change without notice. Customers are advised to consult with FUJITSU sales representatives before ordering.

The information and circuit diagrams in this document presented as examples of semiconductor device applications, and are not intended to be incorporated in devices for actual use. Also, FUJITSU is unable to assume responsibility for infringement of any patent rights or other rights of third parties arising from the use of this information or circuit diagrams.

FUJITSU semiconductor devices are intended for use in standard applications (computers, office automation and other office equipment, industrial, communications, and measurement equipment, personal or household devices, etc.).

#### **CAUTION:**

Customers considering the use of our products in special applications where failure or abnormal operation may directly affect human lives or cause physical injury or property damage, or where extremely high levels of reliability are demanded (such as aerospace systems, atomic energy controls, sea floor repeaters, vehicle operating controls, medical devices for life support, etc.) are requested to consult with FUJITSU sales representatives before such use. The company will not be responsible for damages arising from such use without prior approval.

Any semiconductor devices have inherently a certain rate of failure. You must protect against injury, damage or loss from such failures by incorporating safety design measures into your facility and equipment such as redundancy, fire protection, and prevention of over-current levels and other abnormal operating conditions.

If any products described in this document represent goods or technologies subject to certain restrictions on export under the Foreign Exchange and Foreign Trade Control Law of Japan, the prior authorization by Japanese government should be required for export of those products from Japan.