

MEMORY

Un-buffered

8 M × 64 BIT

SYNCHRONOUS DYNAMIC RAM DIMM

MB8508S064CZ-102/-103/-102L/-103L

168-pin, 4 Clock, 1-bank, based on 8 M × 8 Bit SDRAMs with SPD

DESCRIPTION

The Fujitsu MB8508S064CZ is a fully decoded, CMOS Synchronous Dynamic Random Access Memory (SDRAM) Module consisting of eight MB81F64842C devices which organized as four banks of 8 M × 8 bits and a 2K-bit serial EEPROM on a 168-pin glass-epoxy substrate.

The MB8508S064CZ features a fully synchronous operation referenced to a positive edge clock whereby all operations are synchronized at a clock input which enables high performance and simple user interface coexistence.

The MB8508S064CZ is optimized for those applications requiring high speed, high performance and large memory storage, and high density memory organizations.

This module is ideally suited for workstations, PCs, laser printers, and other applications where a simple interface is needed.

PRODUCT LINE & FEATURES

Parameter		MB8508S064CZ-102/-102L	MB8508S064CZ-103/-103L
CL-trCD-trP		2-2-2 clk min.	3-2-2 clk min.
Clock Frequency		100 MHz max.	100 MHz max.
Burst Mode Cycle Time		10 ns min.	10 ns min.
Output Valid from Clock		6 ns max. (CL = 2)	6 ns max. (CL = 3)
Power Dissipation	Two Banks Active	5472 mW max.	5472 mW max.
	Self Refresh Mode	28.8 mW max. (Std. power) 14.4 mW max. (Low power)	28.8 mW max. (Std. power) 14.4 mW max. (Low power)

- Un-buffered 168-pin DIMM Socket Type (Lead pitch: 1.27 mm)
- Conformed to JEDEC Standard (4 CLK)
- Organization: 8,388,608 words × 64 bits
- Memory: MB81F64842C (8 M × 8, 4-bank) × 8 pcs
- 3.3 V ±0.3 V Supply Voltage
- All input/output LVTTTL compatible
- Conformed to Intel PC/100 spec
- 4096 Refresh Cycle every 65.6 ms
- Auto and Self Refresh
- CKE Power Down Mode
- DQM Byte Masking (Read/Write)
- Serial Presence Detect (SPD) with Serial EEPROM: Intel SPD spec Rev 1.2A Format
- Module size: 1.375" (height) × 5.25" (length) × 0.157" (thickness)

MB8508S064CZ-102/-103/-102L/-103L

■ PACKAGE

168-pin plastic DIMM (socket type)

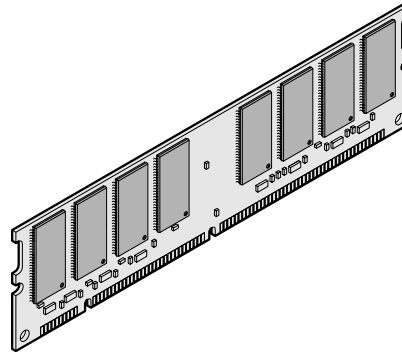

(MDS-168P-P36)

Package and Ordering Information

- 168-pin DIMM, order as MB8508S064CZ-xxxDG (DG = Std. power ver., Gold pad)
MB8508S064CZ-xxxLDG (LDG = Low power ver., Gold pad)

MB8508S064CZ-102/-103/-102L/-103L

■ PIN ASSIGNMENTS

Pin No.	Signal Name	Pin No.	Signal Name	Pin No.	Signal Name	Pin No.	Signal Name	Pin No.	Signal Name	Pin No.	Signal Name
1	V _{SS}	29	DQMB ₁	57	DQ ₁₈	85	V _{SS}	113	DQMB ₅	141	DQ ₅₀
2	DQ ₀	30	\overline{CS}_0	58	DQ ₁₉	86	DQ ₃₂	114	N.C.	142	DQ ₅₁
3	DQ ₁	31	N.C.	59	V _{CC}	87	DQ ₃₃	115	\overline{RAS}	143	V _{CC}
4	DQ ₂	32	V _{SS}	60	DQ ₂₀	88	DQ ₃₄	116	V _{SS}	144	DQ ₅₂
5	DQ ₃	33	A ₀	61	N.C.	89	DQ ₃₅	117	A ₁	145	N.C.
6	V _{CC}	34	A ₂	62	N.C.	90	V _{CC}	118	A ₃	146	N.C.
7	DQ ₄	35	A ₄	63	N.C.	91	DQ ₃₆	119	A ₅	147	N.C.
8	DQ ₅	36	A ₆	64	V _{SS}	92	DQ ₃₇	120	A ₇	148	V _{SS}
9	DQ ₆	37	A ₈	65	DQ ₂₁	93	DQ ₃₈	121	A ₉	149	DQ ₅₃
10	DQ ₇	38	A ₁₀	66	DQ ₂₂	94	DQ ₃₉	122	BA ₀	150	DQ ₅₄
11	DQ ₈	39	BA ₁	67	DQ ₂₃	95	DQ ₄₀	123	A ₁₁	151	DQ ₅₅
12	V _{SS}	40	V _{CC}	68	V _{SS}	96	V _{SS}	124	V _{CC}	152	V _{SS}
13	DQ ₉	41	V _{CC}	69	DQ ₂₄	97	DQ ₄₁	125	CLK ₁	153	DQ ₅₆
14	DQ ₁₀	42	CLK ₀	70	DQ ₂₅	98	DQ ₄₂	126	N.C.	154	DQ ₅₇
15	DQ ₁₁	43	V _{SS}	71	DQ ₂₆	99	DQ ₄₃	127	V _{SS}	155	DQ ₅₈
16	DQ ₁₂	44	N.C.	72	DQ ₂₇	100	DQ ₄₄	128	CKE ₀	156	DQ ₅₉
17	DQ ₁₃	45	\overline{CS}_2	73	V _{CC}	101	DQ ₄₅	129	N.C.	157	V _{CC}
18	V _{CC}	46	DQMB ₂	74	DQ ₂₈	102	V _{CC}	130	DQMB ₆	158	DQ ₆₀
19	DQ ₁₄	47	DQMB ₃	75	DQ ₂₉	103	DQ ₄₆	131	DQMB ₇	159	DQ ₆₁
20	DQ ₁₅	48	N.C.	76	DQ ₃₀	104	DQ ₄₇	132	N.C.	160	DQ ₆₂
21	N.C.	49	V _{CC}	77	DQ ₃₁	105	N.C.	133	V _{CC}	161	DQ ₆₃
22	N.C.	50	N.C.	78	V _{SS}	106	N.C.	134	N.C.	162	V _{SS}
23	V _{SS}	51	N.C.	79	CLK ₂	107	V _{SS}	135	N.C.	163	CLK ₃
24	N.C.	52	N.C.	80	N.C.	108	N.C.	136	N.C.	164	N.C.
25	N.C.	53	N.C.	81	N.C. (WP)	109	N.C.	137	N.C.	165	SA ₀
26	V _{CC}	54	V _{SS}	82	SDA	110	V _{CC}	138	V _{SS}	166	SA ₁
27	\overline{WE}	55	DQ ₁₆	83	SCL	111	\overline{CAS}	139	DQ ₄₈	167	SA ₂
28	DQMB ₀	56	DQ ₁₇	84	V _{CC}	112	DQMB ₄	140	DQ ₄₉	168	V _{CC}

MB8508S064CZ-102/-103/-102L/-103L

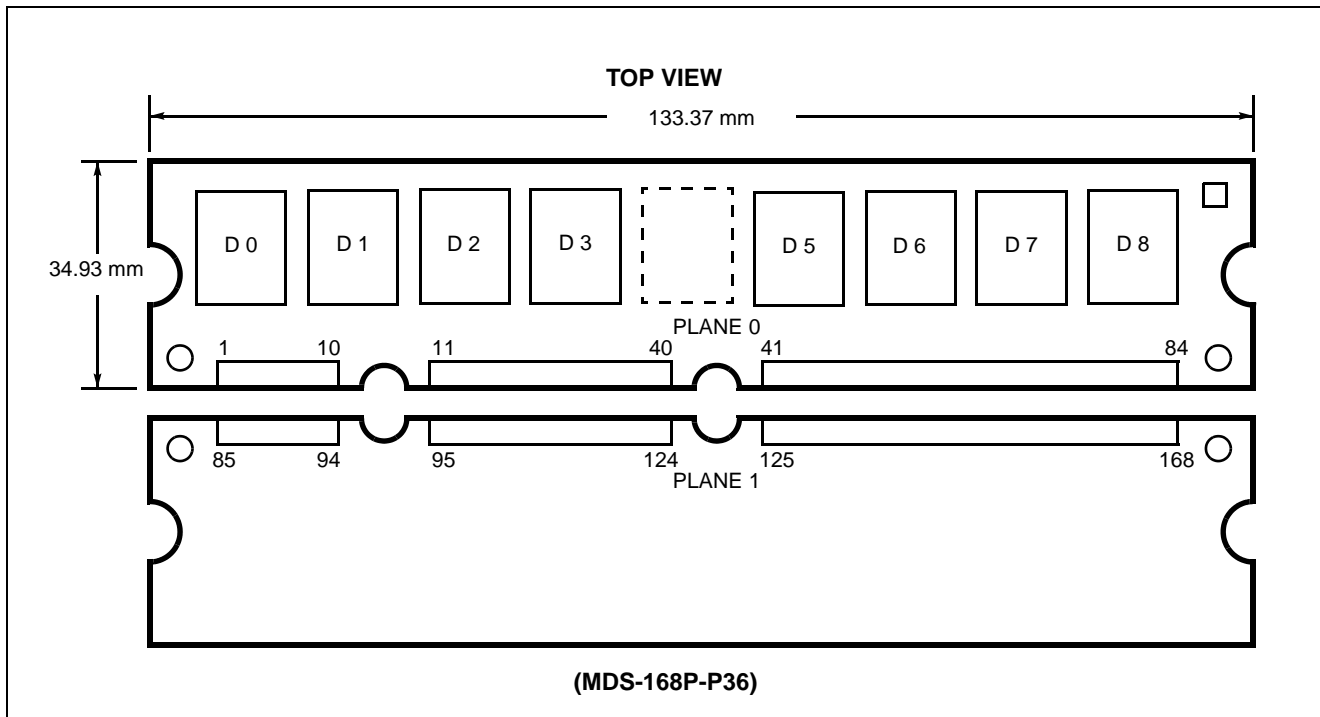

■ PIN DESCRIPTIONS

Symbol	I/O	Function	Symbol	I/O	Function
A ₀ to A ₁₁	I	Address Input	DQ ₀ to DQ ₆₃	I/O	Data Input/Data Output
BA ₀ , BA ₁	I	Bank Select (Bank Address)	V _{CC}	—	Power Supply (+3.3 V)
$\overline{\text{RAS}}$	I	Row Address Strobe	V _{SS}	—	Ground (0 V)
$\overline{\text{CAS}}$	I	Column Address Strobe	N.C.	—	No Connection
$\overline{\text{WE}}$	I	Write Enable	SA ₀ to SA ₂	I	Serial PD Address Input
DQMB ₀ to DQMB ₇	I	Data (DQ) Mask	SCL	I	Serial PD Clock
CLK ₀ to CLK ₃	I	Clock Input	SDA	I/O	Serial PD Address/Data Input/Output
CKE ₀	I	Clock Enable	WP	—	Serial PD Write Protect
$\overline{\text{CS}}_0$, $\overline{\text{CS}}_2$	I	Chip Select			—

MB8508S064CZ-102/-103/-102L/-103L

■ SERIAL-PD INFORMATION

Byte	Function Described		Hex Value	
			-102/ 102L	-103/ 103L
0	Defines Number of Bytes Written into Serial Memory at Module Manufacture	128 Byte	80h	80h
1	Total Number of Bytes of SPD Memory Device	256 Byte	08h	08h
2	Fundamental Memory Type	SDRAM	04h	04h
3	Number of Row Addresses	12	0Ch	0Ch
4	Number of Column Addresses	9	09h	09h
5	Number of Module Banks	1 bank	01h	01h
6	Data Width	64 bit	40h	40h
7	Data Width (Continuation)	+0	00h	00h
8	Interface Type	LVTTTL	01h	01h
9	SDRAM Cycle Time (Highest CAS Latency)	10/10 ns	A0h	A0h
10	SDRAM Access from Clock (Highest CAS Latency)	6/6 ns	60h	60h
11	DIMM Configuration Type	Non-Parity	00h	00h
12	Refresh Rate/Type	Self, Normal	80h	80h
13	Primary SDRAM Width	×8	08h	08h
14	Error Checking SDRAM Width	0	00h	00h
15	Minimum Clock Delay for Back to Back Random Column Addresses	1 Cycle	01h	01h
16	Burst Lengths Supported	1, 2, 4, 8, Page	8Fh	8Fh
17	Number of Banks on Each SDRAM Device	4 bank	04h	04h
18	CAS Latency Supported	2, 3	06h	06h
19	CS Latency	0	01h	01h
20	Write Latency	0	01h	01h
21	SDRAM Module Attributes	UN-buffer	00h	00h
22	SDRAM Device Attributes : General	*1	0Eh	0Eh
23	SDRAM Cycle Time (2nd. Highest CAS Latency)	10/15 ns	A0h	F0h
24	SDRAM Access from Clock (2nd. Highest CAS Latency)	6/8 ns	60h	80h
25	SDRAM Cycle Time (3rd. Highest CAS Latency)	No Support	00h	00h
26	SDRAM Access from Clock (3rd. Highest CAS Latency)	No Support	00h	00h
27	Minimum Row Precharge Time (trp)	20/20 ns	14h	14h
28	Row Activate to Row Activate Minimum (trrd)	20/20 ns	14h	14h
29	RAS to CAS Delay Min. (trcd)	20/20 ns	14h	14h
30	Minimum RAS Pulse Width	50/50 ns	32h	32h
31	Module Bank Density	64 MByte	10h	10h
32	Command and Address Signal Input Setup Time	2 ns	20h	20h
33	Command and Address Signal Input Hold Time	1 ns	10h	10h
34	Data Signal Input Setup Time	2 ns	20h	20h
35	Data Signal Input Hold Time	1 ns	10h	10h
36 to 61	Unused Storage Locations	—	00h	00h
62	SPD Data Revision Code	1.2	12h	12h
63	Checksum for Byte 0 to 62	*2	05h	75h
64 to 71	Manufacturer's JEDEC ID Code Per JEP-108E	Optional	00h	00h
72	Manufacturing Location	Optional	00h	00h
73 to 90	Manufacturer's Part Number	Optional	00h	00h
91 to 92	Revision Code	Optional	00h	00h
93 to 94	Manufacturing Data	Optional	00h	00h
95 to 98	Assembly Serial Number	Optional	00h	00h
99 to 125	Manufacturer Specific Data	Optional	00h	00h
126	Intel Specification Frequency	100 MHz	64h	64h
127	Intel Specification Details for 100 MHz Support	CL = 2, 3 / 3	AFh	ADh
128+	Unused Storage Locations	—	—	—

Note: Any write operation must NOT be executed into the addresses of Byte 0 to Byte 127. Some or all data stored into Byte 0 to Byte 127 may be broken.

*1. Byte 22: SDRAM Device Attributes

Bit7	Bit6	Bit5	Bit4	Bit3	Bit2	Bit1	Bit0
TBD	TBD	Upper V _{CC} tolerance	Lower V _{CC} tolerance	Supports Write 1 /Read Burst	Supports Precharge All	Supports Auto-Precharge	Supports Early RAS Precharge
0	0	0	0	1	1	1	0

*2. Byte 63: Checksum for Byte 0 to 62

This byte is the checksum for Byte 0 through 62. This byte contains the value of the low 8-bits of the arithmetic sum of Byte 0 through 62.

MB8508S064CZ-102/-103/-102L/-103L

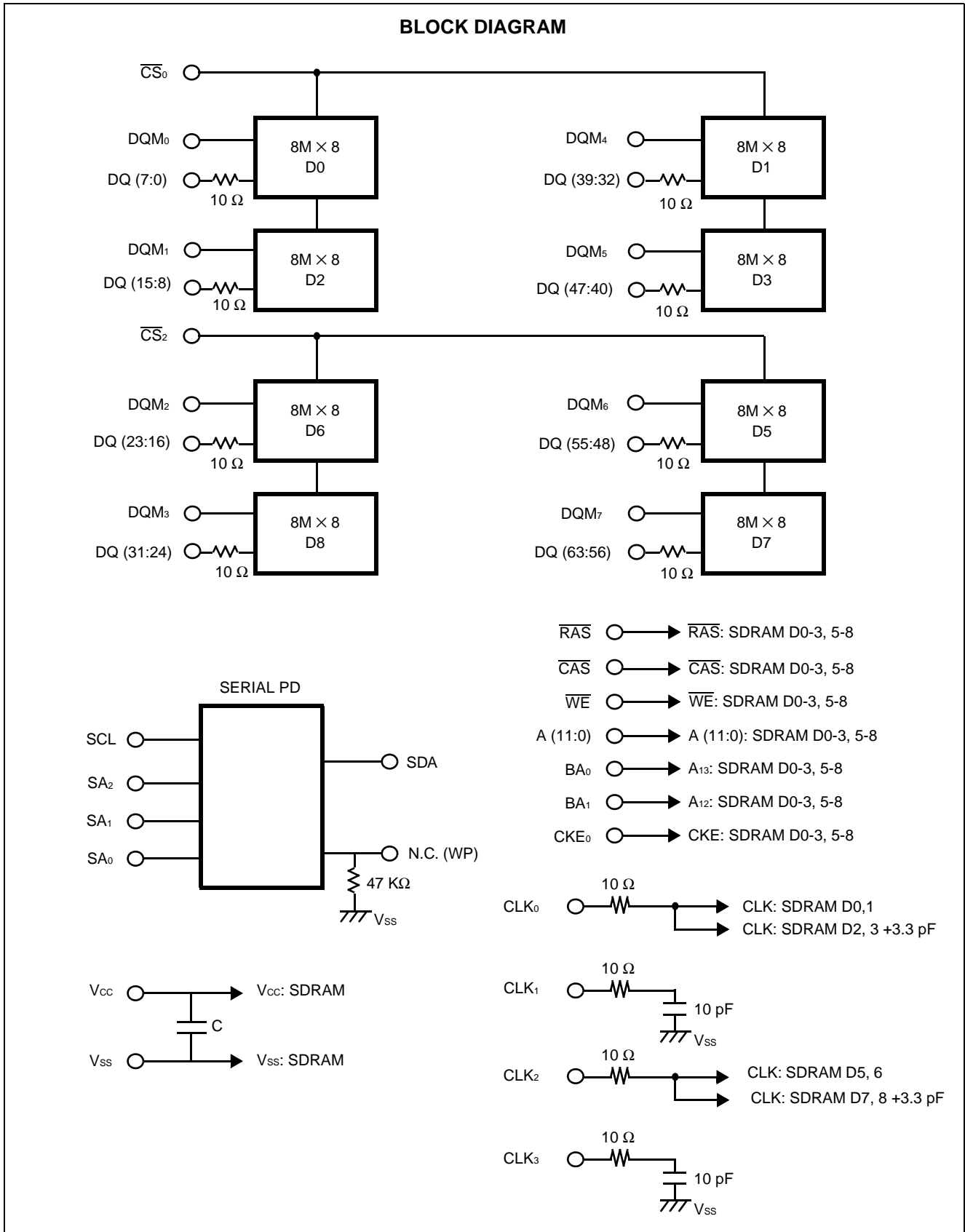

MB8508S064CZ-102/-103/-102L/-103L

■ ABSOLUTE MAXIMUM RATINGS (See WARNING)

Parameter	Symbol	Value		Unit
		Min.	Max.	
Supply Voltage*	V _{CC}	-0.5	+4.6	V
Input Voltage*	V _{IN}	-0.5	+4.6	V
Output Voltage*	V _{OUT}	-0.5	+4.6	V
Storage Temperature	T _{STG}	-55	+125	°C
Power Dissipation	P _D	—	8.0	W
Output Current (D.C.)	I _{OUT}	-50	+50	mA

* : Voltages referenced to V_{SS} (= 0 V)

WARNING: Semiconductor devices can be permanently damaged by application of stress (voltage, current, temperature, etc.) in excess of absolute maximum ratings. Do not exceed these ratings.

■ RECOMMENDED OPERATING CONDITIONS

Parameter	Notes	Symbol	Value			Unit
			Min.	Typ.	Max.	
Supply Voltage	*1	V _{CC}	3.0	3.3	3.6	V
		V _{SS}	0	0	0	V
Input High Voltage, All Inputs	*1, 2	V _{IH}	2.0	—	V _{CC} +0.5	V
Input Low Voltage, All Inputs	*1, 3	V _{IL}	-0.5	—	0.8	V
Ambient Temperature		T _A	0	—	+70	°C

*1. Voltages referenced to V_{SS} (=0V)

*2. Overshoot limit: V_{IH} (max.) = V_{CC} +1.5 V with a pulse-width ≤ 5 ns.

*3. Undershoot limit: V_{IL} (min.) = -1.5 V with a pulse-width ≤ 5 ns.

WARNING: The recommended operating conditions are required in order to ensure the normal operation of the semiconductor device. All of the device's electrical characteristics are warranted when the device is operated within these ranges.

Always use semiconductor devices within their recommended operating condition ranges. Operation outside these ranges may adversely affect reliability and could result in device failure.

No warranty is made with respect to uses, operating conditions, or combinations not represented on the data sheet. Users considering application outside the listed conditions are advised to contact their FUJITSU representatives beforehand.

MB8508S064CZ-102/-103/-102L/-103L

■ CAPACITANCE

($V_{CC} = +3.3\text{ V}$, $f = 1\text{ MHz}$, $T_A = +25^\circ\text{C}$)

Parameter		Symbol	Value		Unit
			Min.	Max.	
Input Capacitance	A_0 to A_{11} , BA_0 , BA_1	C_{IN1}	—	68	pF
	\overline{RAS} , \overline{CAS} , \overline{WE}	C_{IN2}	—	66	pF
	\overline{CS}_0 , \overline{CS}_2	C_{IN3}	—	33	pF
	CKE_0	C_{IN4}	—	58	pF
	CLK_0 to CLK_3	C_{IN5}	—	46	pF
	$DQMB_0$ to $DQMB_7$	C_{IN6}	—	17	pF
	SCL	C_{SCL}	—	7	pF
	SA_0 , SA_1 , SA_2	C_{SA}	—	7	pF
Input/Output Capacitance	SDA	C_{SDA}	—	7	pF
	DQ_0 to DQ_{63}	C_{DQ}	—	13	pF

MB8508S064CZ-102/-103/-102L/-103L

■ DC CHARACTERISTICS

(At recommended operating conditions unless otherwise noted.) Notes 1, 2

Parameter	Notes	Symbol	Condition	Value			Unit
				Min.	Max.		
					Std. ver.	Low ver.	
Operating Current (Average Power Supply Current)	*3	I _{CC1S}	Burst Length = 4, t _{RC} = min for BL = 4, t _{CK} = min, One Bank Active, Outputs Open, Address changed up to 3 times during t _{RC} (min.), 0 V ≤ V _{IN} ≤ V _{CC}	—	840		mA
		I _{CC1D}	Burst Length = 4 (each Bank), t _{RC} = min for BL = 4 (each Bank), t _{CK} = min, Two Banks Active, Outputs Open, Address changed up to 3 times during t _{RC} (min.), 0 V ≤ V _{IN} ≤ V _{CC}	—	1520		mA
Precharge Standby Current (Power Supply Current)	*3	I _{CC2P}	CKE = V _{IL} , t _{CK} = min, All Banks Idle, Power Down Mode, 0 V ≤ V _{IN} ≤ V _{CC}	—	16	8	mA
		I _{CC2PS}	CKE = V _{IL} , CLK = V _{IH} or V _{IL} , All Banks Idle, Power Down Mode, 0 V ≤ V _{IN} ≤ V _{CC}	—	8	4	mA
		I _{CC2N}	CKE = V _{IH} , t _{CK} = min, All Banks Idle, NOP commands only, Input signals (except to CMD) are changed one time during 3 clock cycles, 0 V ≤ V _{IN} ≤ V _{CC}	—	120		mA
		I _{CC2NS}	CKE = V _{IH} , CLK = V _{IH} or V _{IL} , All Banks Idle, Input Signals are Stable, 0 V ≤ V _{IN} ≤ V _{CC}	—	16		mA

(Continued)

MB8508S064CZ-102/-103/-102L/-103L

(Continued)

Parameter	Notes	Symbol	Condition	Value			Unit
				Min.	Max.		
					Std. ver.	Low ver.	
Active Standby Current (Power Supply Current)	*3	I _{CC3P}	CKE = V _{IL} , t _{CK} = min, Any Bank Active, 0 V ≤ V _{IN} ≤ V _{CC}	—	16	8	mA
		I _{CC3PS}	CKE = V _{IL} , CLK = V _{IH} or V _{IL} , Any Bank Active, 0 V ≤ V _{IN} ≤ V _{CC}	—	8	4	mA
		I _{CC3N}	CKE = V _{IH} , t _{CK} = min, Any Bank Active, NOP commands only, Input signals (except to CMD) are changed one time during 3 clock cycles, 0 V ≤ V _{IN} ≤ V _{CC}	—	200		mA
		I _{CC3NS}	CKE = V _{IH} , CLK = V _{IH} or V _{IL} , Any Bank Active, 0 V ≤ V _{IN} ≤ V _{CC}	—	16		mA
Burst Mode Current (Average Power Supply Current)	*3	I _{CC4}	t _{CK} = min, Gapless data, Burst Length = 4, Outputs open, Multiple-banks Active, 0 V ≤ V _{IN} ≤ V _{CC}	—	680		mA
Auto-refresh Current (Average Power Supply Current)	*3	I _{CC5}	Auto Refresh, t _{CK} = min, t _{RC} = min, 0 V ≤ V _{IN} ≤ V _{CC}	—	1920		mA
Self-refresh Current (Average Power Supply Current)	*3	I _{CC6}	Self-refresh, t _{CK} = min, CKE ≤ 0.2 V, 0 V ≤ V _{IN} ≤ V _{CC}	—	8	4	mA
Input Leakage Current (All Inputs)		I _{LI}	0 V ≤ V _{IN} ≤ V _{CC} All other pins not under test = 0 V	-60	60		μA
Output Leakage Current		I _{LO}	Output is disabled (Hi-Z) 0 V ≤ V _{IN} ≤ V _{CC}	-10	10		μA
LVTTL Output High Voltage	*4	V _{OH}	I _{OH} = -2.0 mA	2.4	—		V
LVTTL Output Low Voltage	*4	V _{OL}	I _{OL} = +2.0 mA	—	0.4		V

Notes: *1. An initial pause (DESL on NOP) of 200 μs is required after power-on followed by a minimum of eight Auto-refresh cycles.

*2. DC characteristics is the Serial PD standby state (V_{IN} = GND or V_{CC}).

*3. I_{CC} depends on the output termination, load conditions, clock cycle rate and signal clock rate. The specified values are obtained with the output open and no termination resistors.

*4. Voltages referenced to V_{SS} (= 0 V)

MB8508S064CZ-102/-103/-102L/-103L

■ AC CHARACTERISTICS

(SDRAM Component Specifications) Notes 1, 2, 3

(1) BASE CHARACTERISTICS

(At recommended operating conditions unless otherwise noted.)

No.	Parameter	Notes	Symbol	MB8508S064CZ -102/-102L		MB8508S064CZ -103/-103L		Unit
				Min.	Max.	Min.	Max.	
1	Clock Period	CL = 2	t _{CK2}	10	—	15	—	ns
		CL = 3	t _{CK3}	10	—	10	—	
2	Clock High Time		t _{CH}	3	—	3	—	ns
3	Clock Low Time		t _{CL}	3	—	3	—	ns
4	Input Setup Time		t _{SI}	2	—	2	—	ns
5	Input Hold Time		t _{HI}	1	—	1	—	ns
6	Output Valid from Clock (t _{CLK} = min)	*4, *5 CL = 2	t _{AC2}	—	6	—	8	ns
		CL = 3	t _{AC3}	—	6	—	6	
7	Output in Low-Z		t _{LZ}	0	—	0	—	ns
8	Output in High-Z	*6 CL = 2	t _{HZ2}	3	6	3	8	ns
		CL = 3	t _{HZ3}	3	6	3	6	
9	Output Hold Time		t _{OH}	3	—	3	—	ns
10	Time between Refresh		t _{REF}	—	65.6	—	65.6	ms
11	Transition Time		t _T	0.5	2	0.5	2	ns
12	CKE Setup Time for Power Down Exit Time		t _{CKSP}	3	—	3	—	ns

MB8508S064CZ-102/-103/-102L/-103L

(2) BASE VALUES FOR CLOCK COUNT/LATENCY

No.	Parameter	Notes	Symbol	MB8508S064CZ -102/-102L		MB8508S064CZ -103/-103L		Unit
				Min.	Max.	Min.	Max.	
1	RAS Cycle Time	*7	t _{RC}	70	—	70	—	ns
2	RAS Precharge Time		t _{RP}	20	—	20	—	ns
3	RAS Active Time		t _{RAS}	50	110000	50	110000	ns
4	RAS to CAS Delay Time	*8	t _{RCD}	20	—	20	—	ns
5	Write Recovery Time		t _{WR}	10	—	10	—	ns
6	Data-in to Precharge Lead Time		t _{DPL}	10	—	10	—	ns
7	Data-in to Active/Refresh Command Period	CL = 2	t _{DAL2}	1 cyc + t _{RP}	—	1 cyc + t _{RP}	—	ns
		CL = 3	t _{DAL3}	2 cyc + t _{RP}	—	2 cyc + t _{RP}	—	
8	Mode Register Set Cycle Time		t _{RSC}	20	—	20	—	ns
9	RAS to RAS Bank Active Delay Time		t _{RRD}	20	—	20	—	ns

(3) CLOCK COUNT FORMULA (*9)

$$\text{Clock} \geq \frac{\text{Base Value}}{\text{Clock Period}} \quad (\text{Round off a whole number})$$

(4) LATENCY (The latency values on these parameters are fixed regardless of clock period.)

No.	Parameter	Symbol	MB8508S064CZ -102/-102L	MB8508S064CZ -103/-103L	Unit
1	CKE to Clock Disable	l _{CKE}	1	1	Cycle
2	DQM to Output in High-Z	l _{DQZ}	2	2	Cycle
3	DQM to Input Data Delay	l _{DQD}	0	0	Cycle
4	Last Output to Write Command Delay	l _{OWD}	2	2	Cycle
5	Write Command to Input Data Delay	l _{DWD}	0	0	Cycle
6	Precharge to Output in High-Z Delay	CL = 2	l _{ROH2}	2	Cycle
		CL = 3	l _{ROH3}	3	
7	Burst Stop Command to Output in High-Z Delay	CL = 2	l _{BSH2}	2	Cycle
		CL = 3	l _{BSH3}	3	
8	CAS to CAS Delay (min)	l _{CCD}	1	1	Cycle
9	CAS Bank Delay (min)	l _{CBD}	1	1	Cycle

MB8508S064CZ-102/-103/-102L/-103L

- Notes:**
- *1. An initial pause (DESL on NOP) of 200 μ s is required after power-up followed by a minimum of eight Auto-refresh cycles.
 - *2. 1.4 V or V_{REF} is the reference level for measuring timing of signals. Transition times are measured between V_{IH} (min) and V_{IL} (max).
 - *3. AC characteristics assume $t_r = 1$ ns and 50 pF of capacitance load.
 - *4. Assumes t_{RCD} is satisfied.
 - *5. t_{AC} also specifies the access time at burst mode except for first access.
 - *6. Specified where output buffer is no longer driven.
 - *7. Actual clock count of t_{RC} (I_{RC}) will be sum of clock count of t_{RAS} (I_{RAS}) and t_{RP} (I_{RP}).
 - *8. Operation within the t_{RCD} (min) ensures that access time is determined by t_{RCD} (min) + t_{AC} (max) ; if t_{RCD} is greater than the specified t_{RCD} (min), access time is determined by t_{AC} .
 - *9. All base values are measured from the clock edge at the command input to the clock edge for the next command input.
All clock counts are calculated by a simple formula:
clock count equals base value divided by clock period (round off to a whole number).

*Source: See MB81F64842C Data Sheet for details on the electrical.

■ AC OPERATING TEST CONDITION (Example of AC Test Load Circuit)

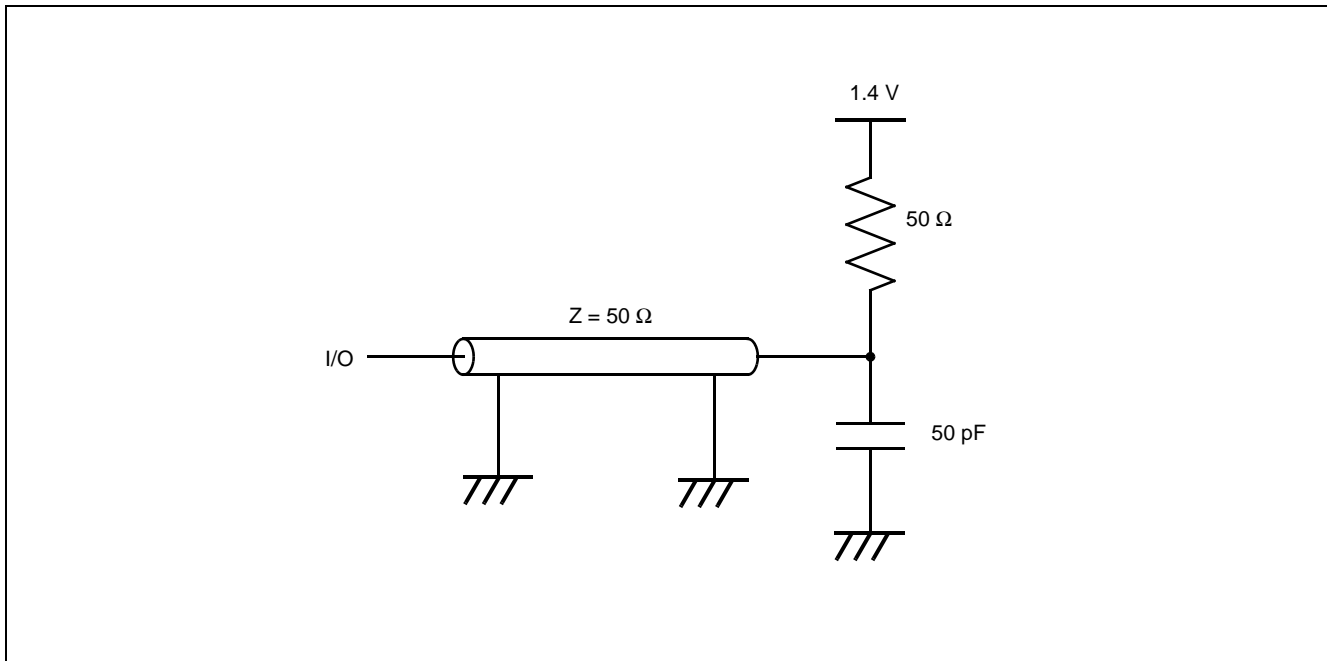

MB8508S064CZ-102/-103/-102L/-103L

■ SERIAL PRESENCE DETECT (SPD) FUNCTION

1. PIN DESCRIPTIONS

SCL (Serial Clock)

SCL input is used to clock all data input/output of SPD.

SDA (Serial Data)

SDA is a common pin used for all data input/output of SPD. The SDA pull-up resistor is required due to the open-drain output.

SA₀, SA₁, SA₂ (Address)

Address inputs are used to set the least significant three bits of the eight bits slave address. The address inputs must be fixed to select a particular module and the fixed address of each module must be different each other.

2. SPD OPERATIONS

CLOCK and DATA CONVENTION

Data states on the SDA can change only during SCL = Low. SDA state changes during SCL = High are indicated start and stop conditions. Refer to Fig. 1 below.

START CONDITION

All commands are preceded by a start condition, which is a transition of SDA state from High to Low when SCL = High. SPD will not respond to any command until this condition has been met.

STOP CONDITION

All read or write operation must be terminated by a stop condition, which is a transition of SDA state from Low to High when SCL = High. The stop condition is also used to make the SPD into the state of standby power mode after a read sequence.

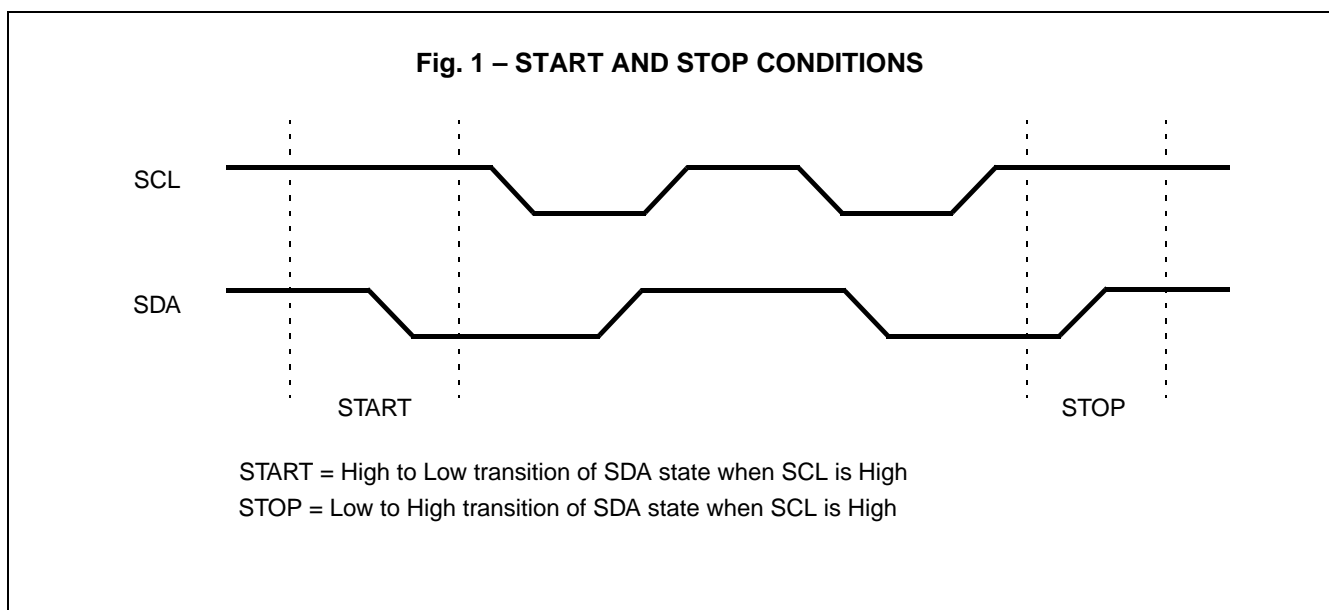

MB8508S064CZ-102/-103/-102L/-103L

ACKNOWLEDGE

Acknowledge is a software convention used to indicate successful data transfer. The transmitting device, either master or slave, will release the bus after transmitting eight bits. During the ninth clock cycle the receiver will put the SDA line to Low in order to acknowledge that it received the eight bits of data.

The SPD will respond with an acknowledge when it received the start condition followed by slave address issued by master.

In the read operation, the SPD will transmit eight bits of data, release the SDA line and monitor the line for an acknowledge. If an acknowledge is detected and no stop condition is issued by master, the SPD will continue to transmit data. If an acknowledge is not detected, the SPD will terminated further data transmissions. The master must then issue a stop condition to return the SPD to the standby power mode.

In the write operation, upon receipt of eight bits of data the SPD will respond with an acknowledge, and await the next eight bits of data, again responding with an acknowledge until the stop condition is issued by master.

SLAVE ADDRESS ADDRESSING

Following a start condition, the master must output the eight bits slave address. The most significant four bits of the slave address are device type identifier. For the SPD this is fixed as 1010[B]. Refer to the Fig. 2 below.

The next three significant bits are used to select a particular device. A system could have up to eight SPD devices —namely up to eight modules— on the bus. The eight addresses for eight SPD devices are defined by the state of the SA₀, SA₁ and SA₂ inputs.

The last bit of the slave address defines the operation to be performed. When R/W bit is “1”, a read operation is selected, when R/W bit is “0”, a write operation is selected.

Following the start condition, the SPD monitors the SDA line comparing the slave address being transmitted with its slave address (device type and state of SA₀, SA₁, and SA₂ inputs). Upon a correct compare the SPD outputs an acknowledge on the SDA line. Depending on the state of the R/W bit, the SPD will execute a read or write operation.

Fig. 2 – SLAVE ADDRESS

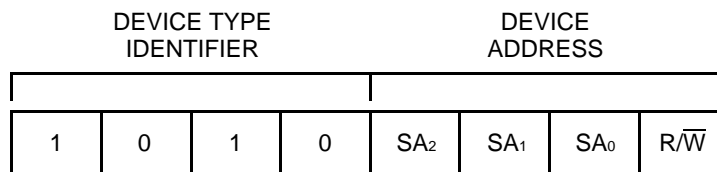

MB8508S064CZ-102/-103/-102L/-103L

3. READ OPERATIONS

CURRENT ADDRESS READ

Internally the SPD contains an address counter that maintains the address of the last data accessed, incremented by one. Therefore, if the last access (either a read or write operation) was to address(n), the next read operation would access data from address(n+1). Upon receipt of the slave address with the R/\bar{W} bit = "1", the SPD issues an acknowledge and transmits the eight bits of data during the next eight clock cycles. The master terminates this transmission by issuing a stop condition, omitting the ninth clock cycle acknowledge. Refer to Fig. 3 for the sequence of address, acknowledge and data transfer.

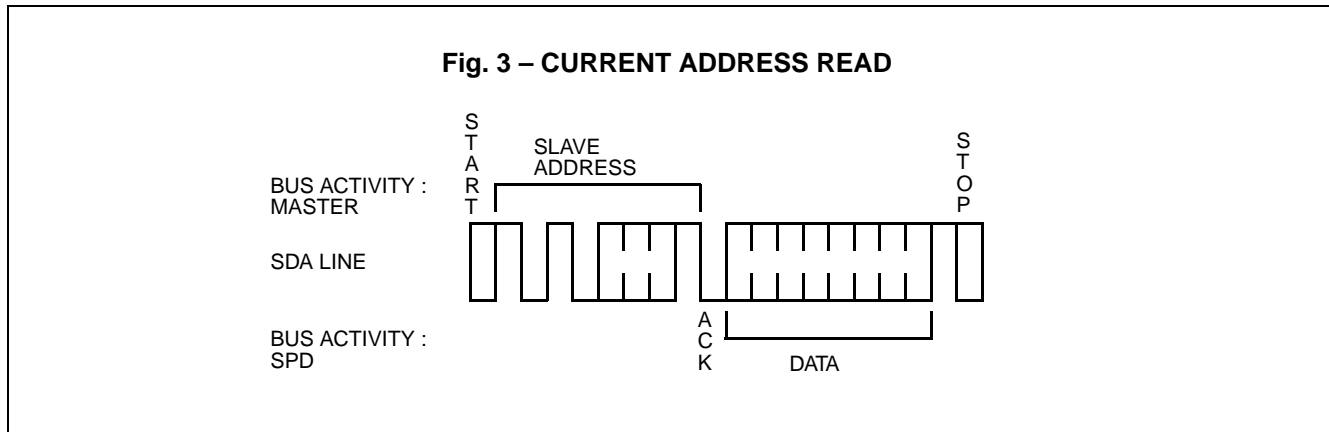

RANDOM READ

Random Read operations allow the master to access any memory location in a random manner. Prior to issuing the slave address with the R/\bar{W} bit = "1", the master must first perform a "dummy" write operation on the SPD. The master issues the start condition, and the slave address followed by the word address. After the word address acknowledge, the master immediately reissues the start condition and the slave address with the R/\bar{W} bit = "1". This will be followed by an acknowledge from the SPD and then by the eight bits of data. The master terminates this transmission by issuing a stop condition, omitting the ninth clock cycle acknowledge. Refer to Fig. 4 for the sequence of address, acknowledge and data transfer.

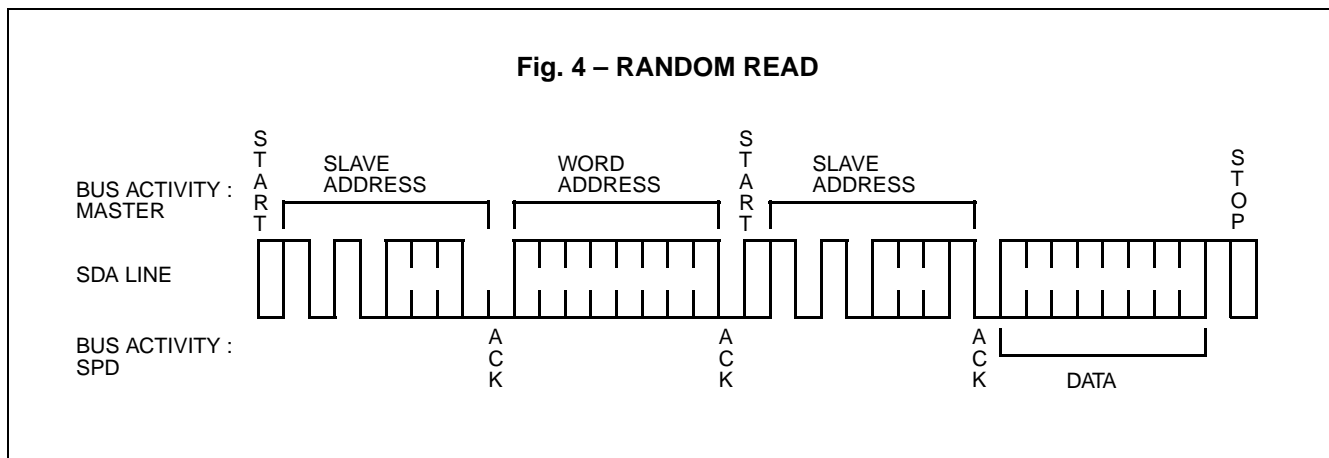

MB8508S064CZ-102/-103/-102L/-103L

SEQUENTIAL READ

Sequential Read can be initiated as either a current address read or random read. The first data are transmitted as with the other read mode, however, the master now responds with an acknowledge, indicating it requires additional data. The SPD continues to output data for each acknowledge received. The master terminates this transmission by issuing a stop condition, omitting the ninth clock cycle acknowledge. Refer to Fig. 5 for the sequence of address, acknowledge and data transfer.

The data output is sequential, with the data from address(n) followed by the data from address(n+1). The address counter for read operations increments all address bits, allowing the entire memory contents to be serially read during one operation. At the end of the address space (address 255), the counter “rolls over” to address 0 and the SPD continues to output data for each acknowledge received.

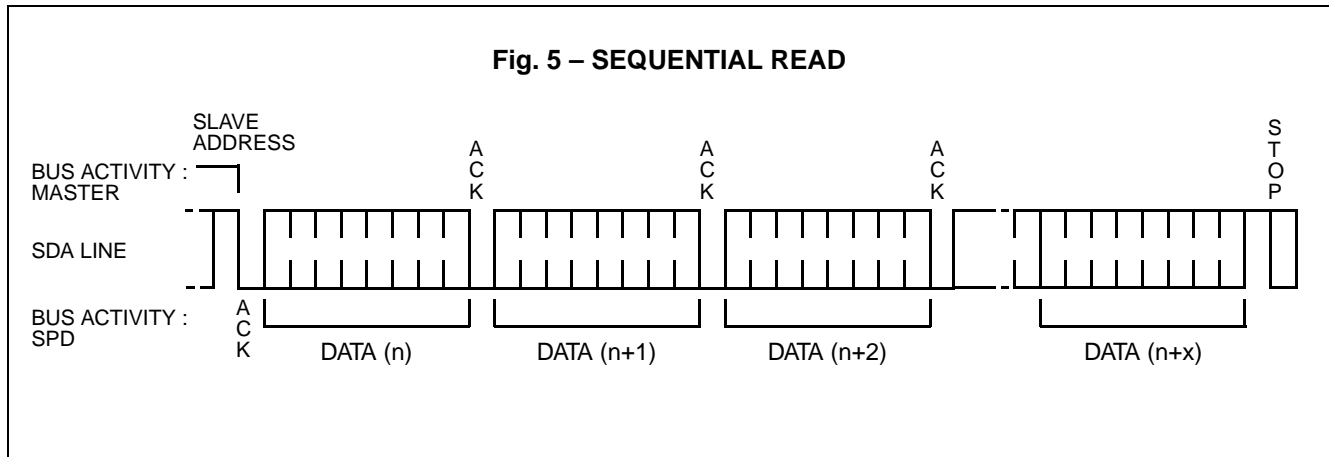

4. DC CHARACTERISTICS

Parameter	Note	Symbol	Condition	Value		Unit
				Min.	Max.	
Input Leakage Current		S_{IL}	$0\text{ V} \leq V_{IN} \leq V_{CC}$	-10	10	μA
Output Leakage Current		S_{ILO}	$0\text{ V} \leq V_{OUT} \leq V_{CC}$	-10	10	μA
Output Low Voltage	*1	S_{VOL}	$I_{OL} = 3.0\text{ mA}$	—	0.4	V

Note: *1. Referenced to V_{SS} .

MB8508S064CZ-102/-103/-102L/-103L

5. AC CHARACTERISTICS

No.	Parameter	Symbol	Value		Unit
			Min.	Max.	
1	SCL Clock Frequency	f_{SCL}	—	100	KHz
2	Noise Suppression Time Constant at SCL, SDA Inputs	T_I	—	100	ns
3	SCL Low to SDA Data Out Valid	t_{AA}	—	3.5	μs
4	Time the Bus Must Be Free Before a New Transmission Can Start	t_{BUF}	4.7	—	μs
5	Start Condition Hold Time	$t_{HD:STA}$	4.0	—	μs
6	Clock Low Period	t_{LOW}	4.7	—	μs
7	Clock High Period	t_{HIGH}	4.0	—	μs
8	Start Condition Setup Time	$t_{SU:STA}$	4.7	—	μs
9	Data in Hold Time	$t_{HD:DAT}$	0	—	μs
10	Data in Setup Time	$t_{SU:DAT}$	250	—	ns
11	SDA and SCL Rise Time	t_R	—	1	μs
12	SDA and SCL Fall Time	t_F	—	300	ns
13	Stop Condition Setup Time	$t_{SU:STO}$	4.7	—	μs
14	Data Out Hold Time	t_{DH}	100	—	ns
15	Write Cycle Time	t_{WR}	—	15	ms

Fig. 6 – TIMING WAVEFORM

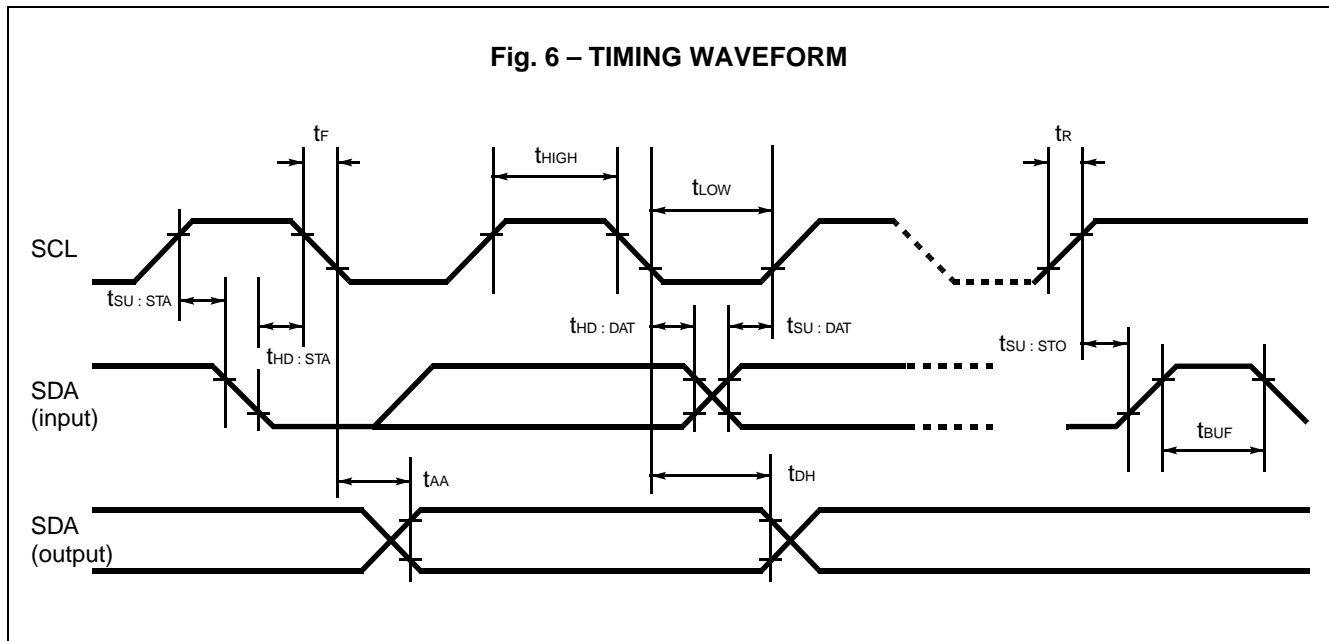

MB8508S064CZ-102/-103/-102L/-103L

■ PACKAGE DIMENSION

168-pin plastic DIMM (socket type)
(MDS-168P-P36)

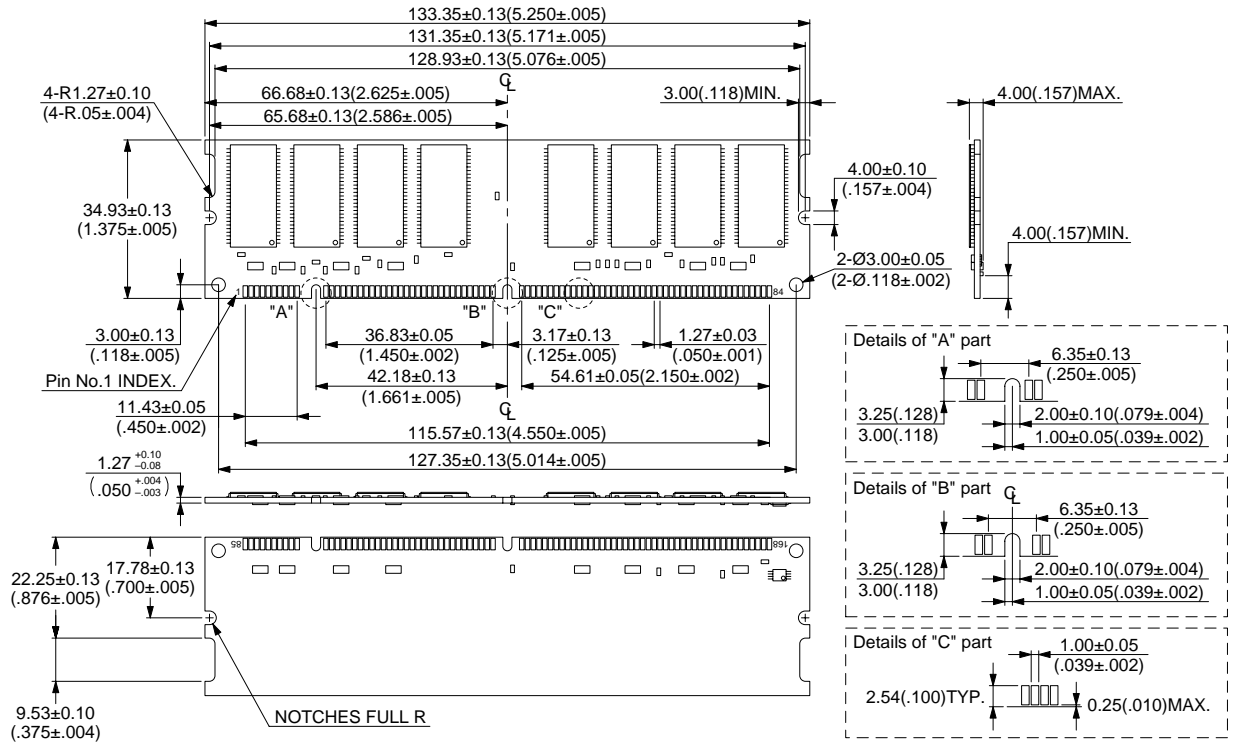

© 1998 FUJITSU LIMITED M168036SC-1-1

Dimension in mm (inches)

MB8508S064CZ-102/-103/-102L/-103L**FUJITSU LIMITED**

For further information please contact:

Japan

FUJITSU LIMITED
Corporate Global Business Support Division
Electronic Devices
KAWASAKI PLANT, 4-1-1, Kamikodanaka
Nakahara-ku, Kawasaki-shi
Kanagawa 211-8588, Japan
Tel: 81(44) 754-3763
Fax: 81(44) 754-3329

<http://www.fujitsu.co.jp/>

North and South America

FUJITSU MICROELECTRONICS, INC.
Semiconductor Division
3545 North First Street
San Jose, CA 95134-1804, USA
Tel: (408) 922-9000
Fax: (408) 922-9179

Customer Response Center
Mon. - Fri.: 7 am - 5 pm (PST)
Tel: (800) 866-8608
Fax: (408) 922-9179

<http://www.fujitsumicro.com/>

Europe

FUJITSU MIKROELEKTRONIK GmbH
Am Siebenstein 6-10
D-63303 Dreieich-Buchsschlag
Germany
Tel: (06103) 690-0
Fax: (06103) 690-122

<http://www.fujitsu-edc.com/>

Asia Pacific

FUJITSU MICROELECTRONICS ASIA PTE LTD
#05-08, 151 Lorong Chuan
New Tech Park
Singapore 556741
Tel: (65) 281-0770
Fax: (65) 281-0220

<http://www.fmap.com.sg/>

F9812

© FUJITSU LIMITED Printed in Japan

All Rights Reserved.

The contents of this document are subject to change without notice. Customers are advised to consult with FUJITSU sales representatives before ordering.

The information and circuit diagrams in this document are presented as examples of semiconductor device applications, and are not intended to be incorporated in devices for actual use. Also, FUJITSU is unable to assume responsibility for infringement of any patent rights or other rights of third parties arising from the use of this information or circuit diagrams.

FUJITSU semiconductor devices are intended for use in standard applications (computers, office automation and other office equipment, industrial, communications, and measurement equipment, personal or household devices, etc.).

CAUTION:

Customers considering the use of our products in special applications where failure or abnormal operation may directly affect human lives or cause physical injury or property damage, or where extremely high levels of reliability are demanded (such as aerospace systems, atomic energy controls, sea floor repeaters, vehicle operating controls, medical devices for life support, etc.) are requested to consult with FUJITSU sales representatives before such use. The company will not be responsible for damages arising from such use without prior approval.

Any semiconductor devices have an inherent chance of failure. You must protect against injury, damage or loss from such failures by incorporating safety design measures into your facility and equipment such as redundancy, fire protection, and prevention of over-current levels and other abnormal operating conditions.

If any products described in this document represent goods or technologies subject to certain restrictions on export under the Foreign Exchange and Foreign Trade Law of Japan, the prior authorization by Japanese government will be required for export of those products from Japan.