

ASSP

1CHANNEL 10-BIT D/A CONVERTER

MB40760

■ DESCRIPTION

MB40760 is a low-power consumption, high-speed 10-bit D/A converter.

The MB40760 is characterized by TTL compatible digital inputs, an analog output voltage from 3 to 5V, and a maximum conversion rate of 60 MHz. It provides a reference voltage from a potential divider and band-gap reference, and can also use an external reference voltage.

The MB40760 D/A converter is suitable for high-resolution TVs or VTRs.

■ FEATURES

- Resolution: 10 bits
- Conversion characteristics:
 - Maximum conversion rate: 60 MHz (Minimum)
 - Linearity error: $\pm 0.1\%$ (Maximum)
 - Differential linearity error: $\pm 0.1\%$ (Maximum)
- Input and output:
 - Digital input voltage: TTL levels
 - Analog output voltage: 2 V_{P-P} (3V to 5V)
- Reference voltage
 - V_{ROUT1}: Potential divider circuit (0.6 V_{CCA})
 - V_{ROUT2}: Band-gap reference circuit (V_{CCA}-2V)
- Others
 - Supply voltage: +5V single power supply
 - Power dissipation: 180 mW (Typical value at analog output voltage 2 VP-P)
 - 140 mW (Typical value at analog output voltage 1 VP-P)

■ PACKAGES

Plastic DIP, 20 pin

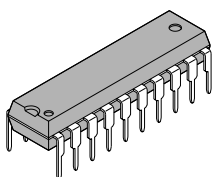

(DIP-20P-M01)

Plastic SOP, 20 pin

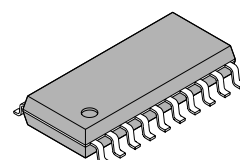

(FPT-20P-M01)

MB40760

■ PIN ASSIGNMENT

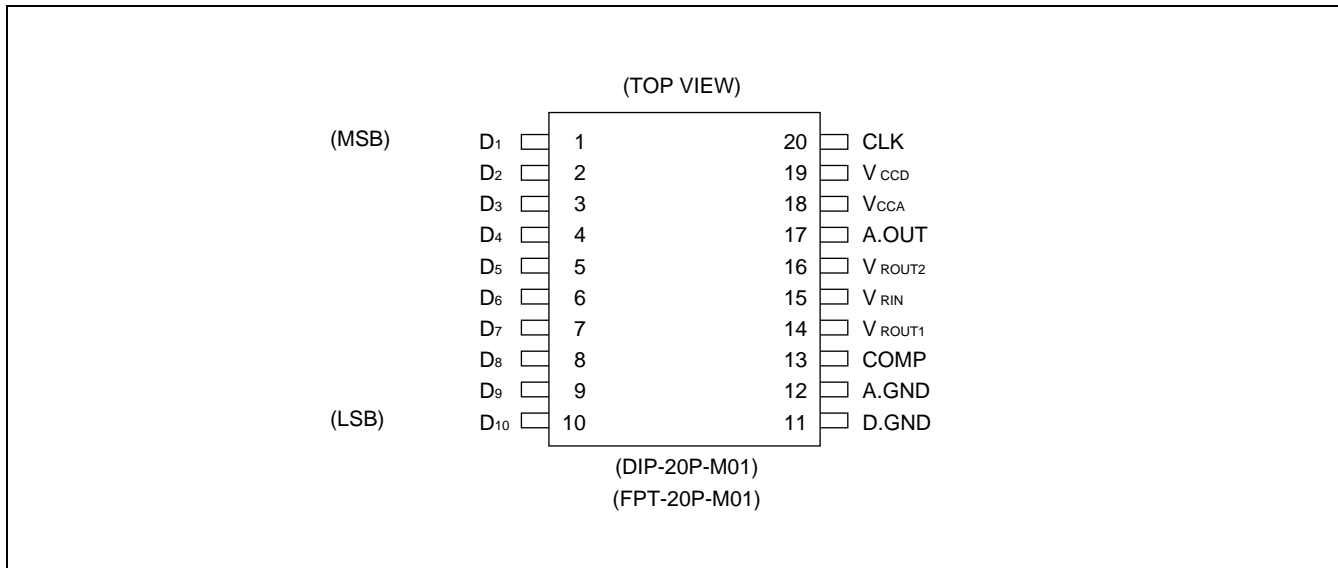

■ PIN DESCRIPTIONS

Pin No.	Symbol	I/O	Description
1 to 10	D1 to D10	I	Data signal input pin (D1: MSB, D10: LSB)
20	CLK	I	Clock signal input pin
19	VCCD	—	Digital power pin (+5V)
18	VCCA	—	Analog power pin (+5 V)
11	D.GND	—	Digital ground pin (0V)
12	A.GND	—	Analog ground pin (0V)
15	VRIN	I	Reference voltage input pin Analog output dynamic range setup pin Connect to pin 14 or 16 to use the built-in reference voltage When using an external reference voltage, the voltage on this pin must be from 2.7V to 4.3V, and VCCA-VRIN must be from 0.7V to 2.2V
14	VROUT1	O	Reference voltage output pin 1 The output voltage of the potential divider reference is fixed at 0.6 VCCA. When this pin is connected to pin 15, the analog output voltage ranges from 0.6 VCCA to VCCA
16	VROUT2	O	Reference voltage output pin 2 The output voltage of the band-gap reference is fixed at VCCA-2.0(V). When the pin is connected to pin 15, the analog output voltage ranges from VCCA-2.0(V) to VCCA
13	COMP	—	Phase compensation capacitor pin Insert a capacitor of 0.1 μF or greater between A.GND and COMP for phase compensation
17	A.OUT	O	Analog signal output pin

MB40760

■ BLOCK DIAGRAM

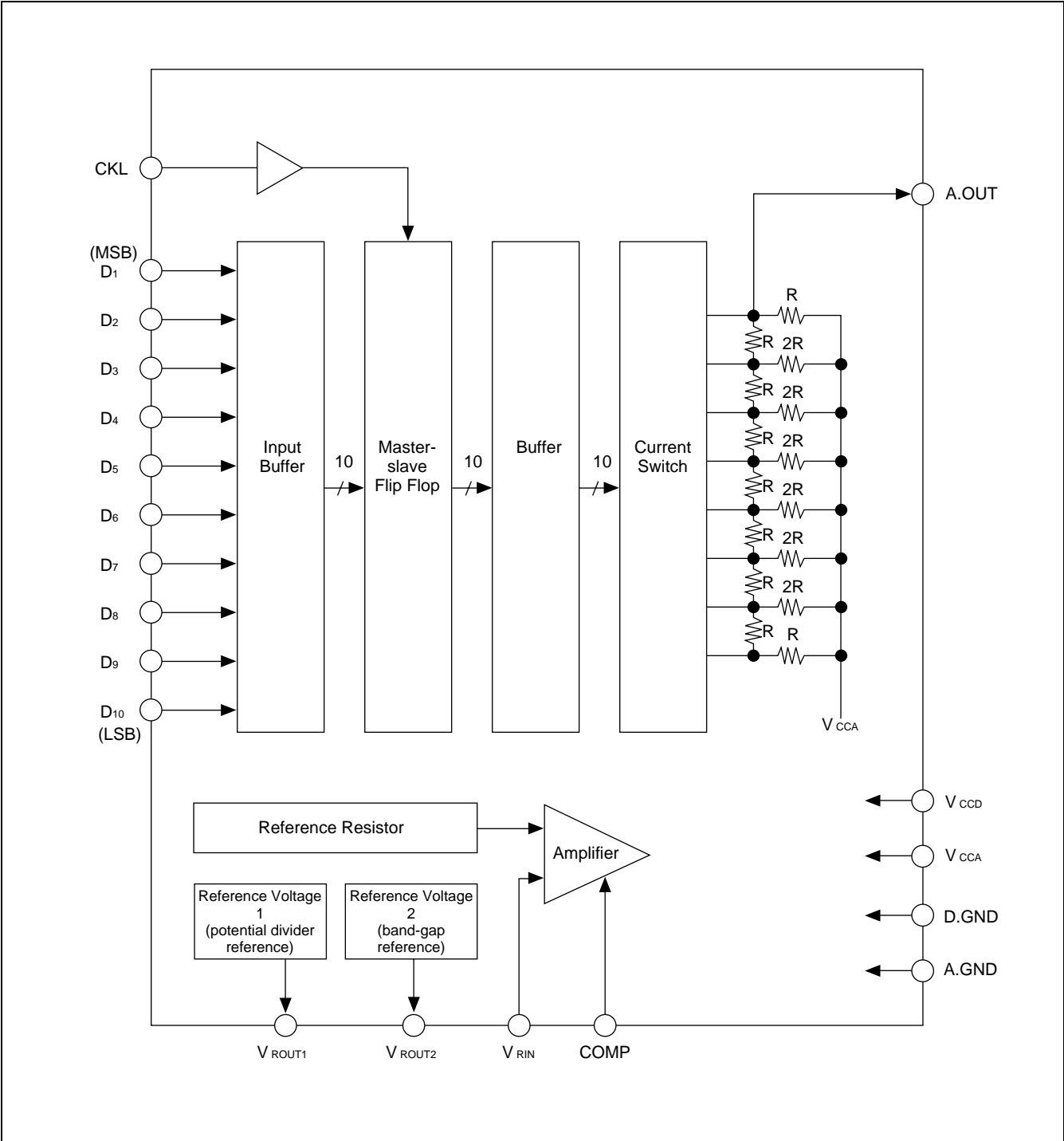

MB40760

■ DIGITAL INPUT EQUIVALENT CIRCUIT

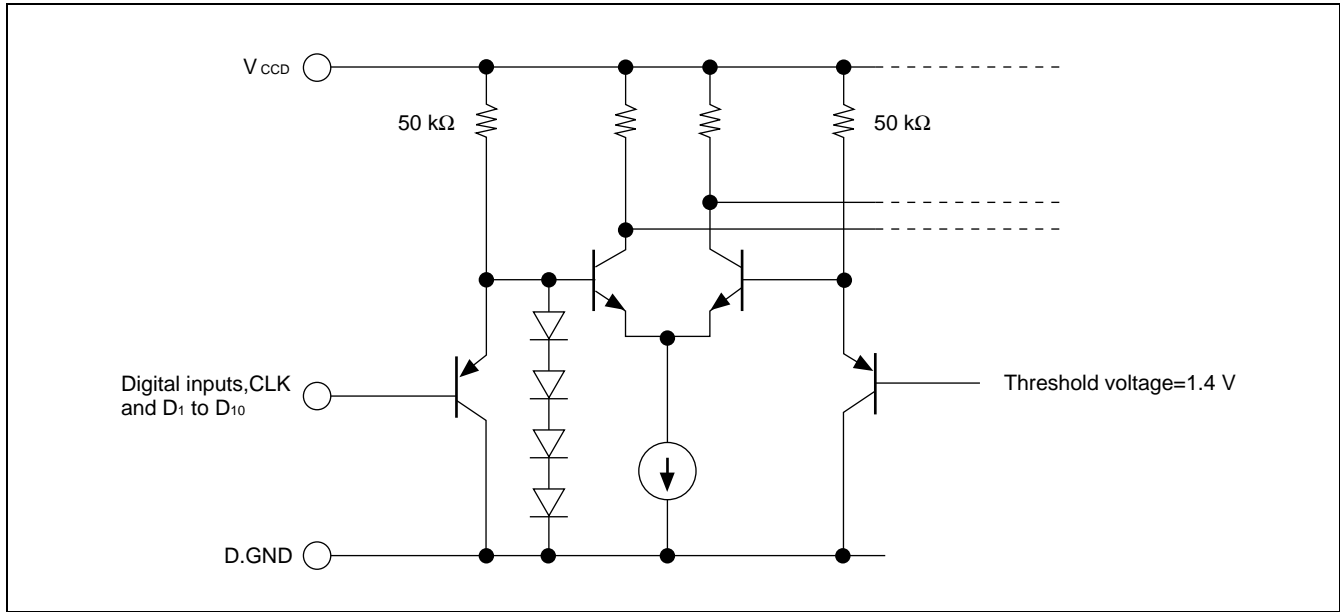

■ ANALOG OUTPUT EQUIVALENT CIRCUIT

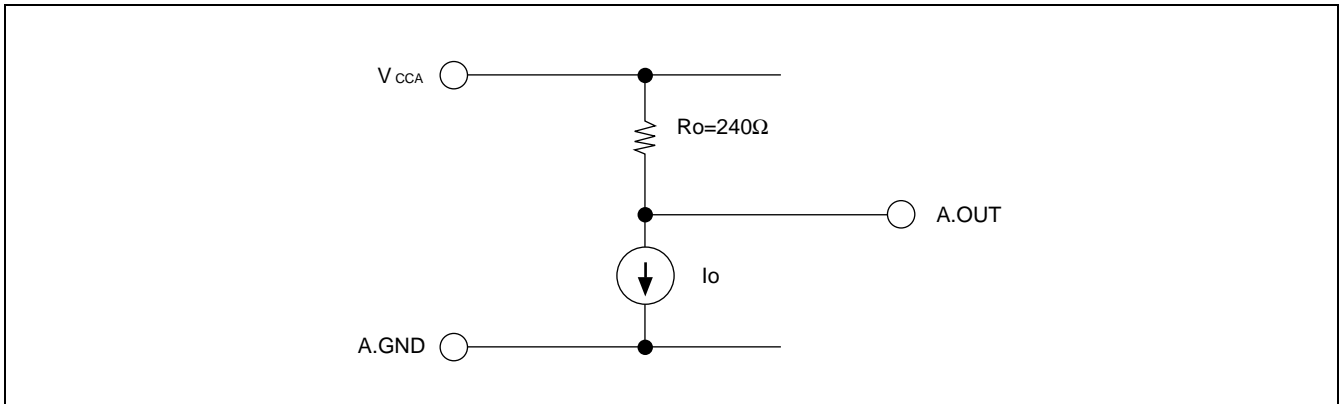

■ REFERENCE VOLTAGE OUTPUT EQUIVALENT CIRCUIT

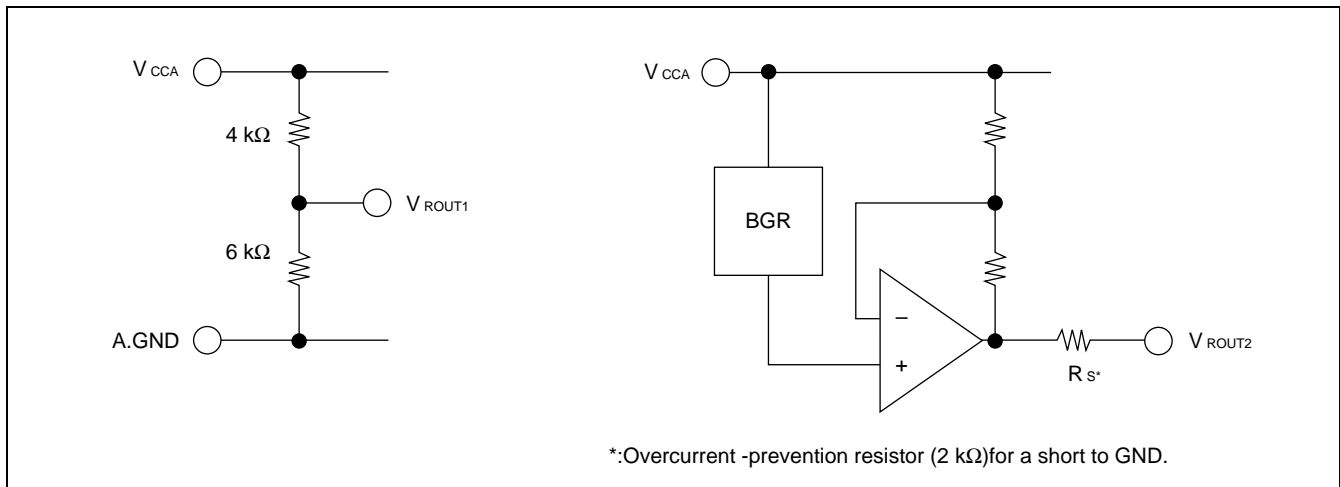

■ TYPICAL CONNECTION EXAMPLE

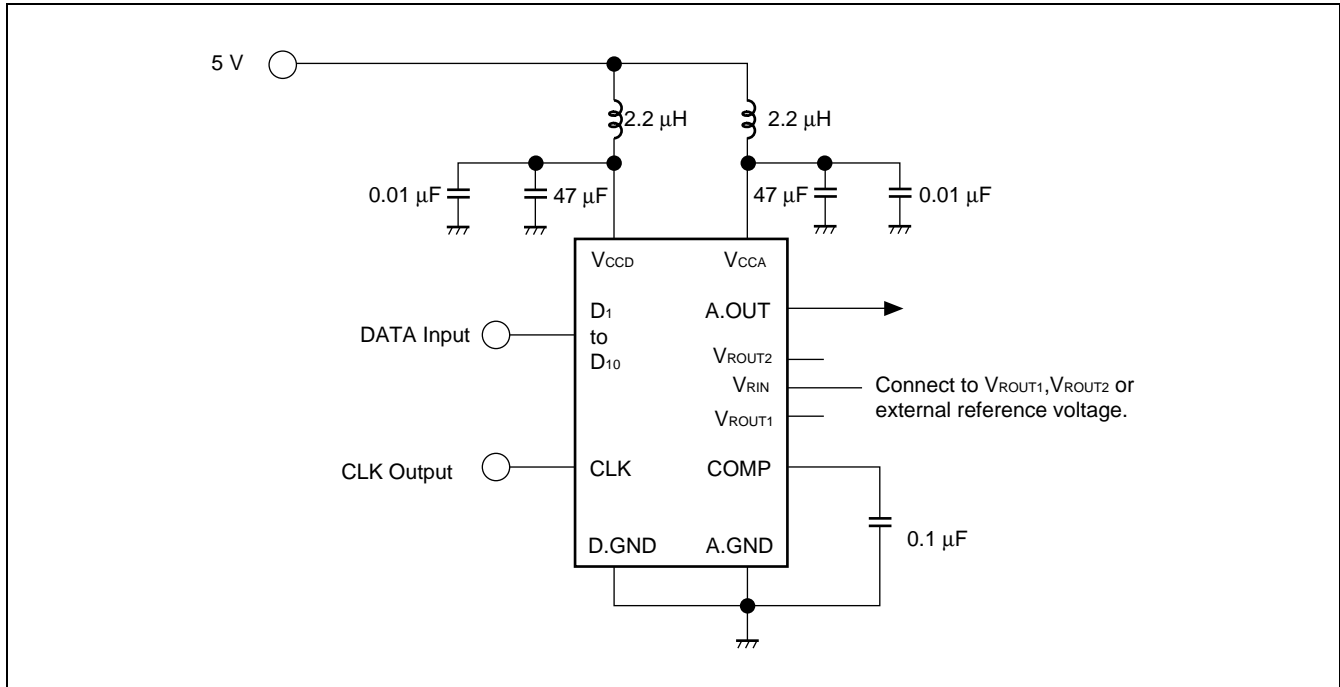

MB40760

■ ABSOLUTE MAXIMUM RATINGS

(A.GND = D.GND = 0V, Ta = +25°C)

Parameter	Symbol	Value	Unit
Analog power supply voltage	V _{CCA}	-0.5 to +7.0	V
Digital power supply voltage	V _{CCD}	-0.5 to +7.0	V
Power supply voltage difference	V _{CCD} -V _{CCA}	1.5	V
Digital signal input voltage	V _{ID}	-0.5 to +7.0	V
Storage Temperature	T _{stg}	-55 to +125	°C

Note: Permanent device damage may occur if the above Absolute Maximum Rating are exceeded. Functional operation should be restricted to the conditions as detailed in the operational sections of this data sheet. Exposure to absolute maximum rating conditions for extended periods may affect device reliability.

■ RECOMMENDED OPERATING CONDITIONS

(A.GND = D.GND = 0V, Ta = -20°C to +75°C)

Parameter		Symbol	Standard values			Unit
			Min.	Typ.	Max.	
Power supply voltage	Analog power supply voltage	V _{CCA}	4.75	5.00	5.25	V
	Digital power supply voltage	V _{CCD}	4.75	5.00	5.25	V
	Power supply voltage difference	V _{CCA} -V _{CCD}	-0.2	—	0.2	V
Analog reference voltage	V _{CCA} -V _{RIN}	0.70	2.00	2.20	V	
	V _{RIN}	2.65	3.00	4.30	V	
Digital input high voltage		V _{IHD}	2.0	—	—	V
Digital input low voltage		V _{ILD}	—	—	0.8	V
Clock frequency		f _{CLK}	—	—	60	MHz
Setup time		t _{su}	8	—	—	ns
Hold time		t _h	2	—	—	ns
Clock minimum pulse width high		t _{WH}	6.5	—	—	ns
Clock minimum pulse width low		t _{WL}	6.5	—	—	ns
Phase compensation capacitor		C _{COMP}	0.1	—	—	μF
Operating temperature		T _{OP}	-20	—	75	°C

MB40760

■ DC CHARACTERISTICS

(V_{CCA} = V_{CCD} = 4.75 to 5.25V, A.GND = D.GND = 0V, Ta = -20°C to +75°C)

Parameter	Symbol	Conditions	Standard values			Unit
			Min.	Typ.	Max.	
Resolution	—	—	—	—	10	bit
Linearity error	LE	DC accuracy	—	—	±0.1	%
Differential linearity error	DLE		—	—	±0.1	%
Digital input current high	I _{IHD}	V _{IHD} = 2.7V	—	—	20	μA
Digital input current low	I _{ILD}	V _{ILD} = 0.4V	-100	—	—	μA
Reference input current	I _{RIN}	V _{RIN} = 3.000V	—	—	10	μA
Potential divider reference	Reference voltage	V _{ROUT1} V _{CCA} = 5.00V V _{CCD} = 5.00V	2.900	3.000	3.100	V
Band-gap reference	Reference voltage	V _{ROUT2}	V _{CCA} -2.100	V _{CCA} -2.000	V _{CCA} -1.900	V
	Temperature coefficient	—	—	100	—	ppm/°C
Full-scale output voltage	V _{OFS}	—	V _{CCA} -20	V _{CCA}	—	mV
Zero-scale output voltage	V _{OZS}	V _{CCA} = 5.00V V _{CCD} = 5.0V V _{RIN} = 3.000V	2.932	3.002	3.072	V
Output resistance	R _o	Ta = +25°C	192	240	288	Ω
Power dissipation	I _{CC}	V _{CCA} = 5.25V V _{CCD} = 5.25V V _{RIN} = V _{ROUT1}	—	36*	62	mA

* : V_{CCA} = V_{CCD} = 5V

■ AC CHARACTERISTICS

(V_{CCA} = V_{CCD} = 4.75 to 5.25V, A.GND = D.GND = 0V, Ta = -20°C to +75°C)

Parameter	Symbol	Conditions	Standard values			Unit
			Min.	Typ.	Max.	
Maximum conversion rate	F _s	C _L = 15pF A.OUT pin terminating resistance = 240Ω	60	—	—	MSPS
Output propagation delay time	t _{pd}		—	7	—	ns
Output rise time	t _r		—	5	—	ns
Output fall time	t _f		—	5	—	ns
Settling time	t _{set}		—	17.5	—	ns

MB40760

■ TIMING CHART

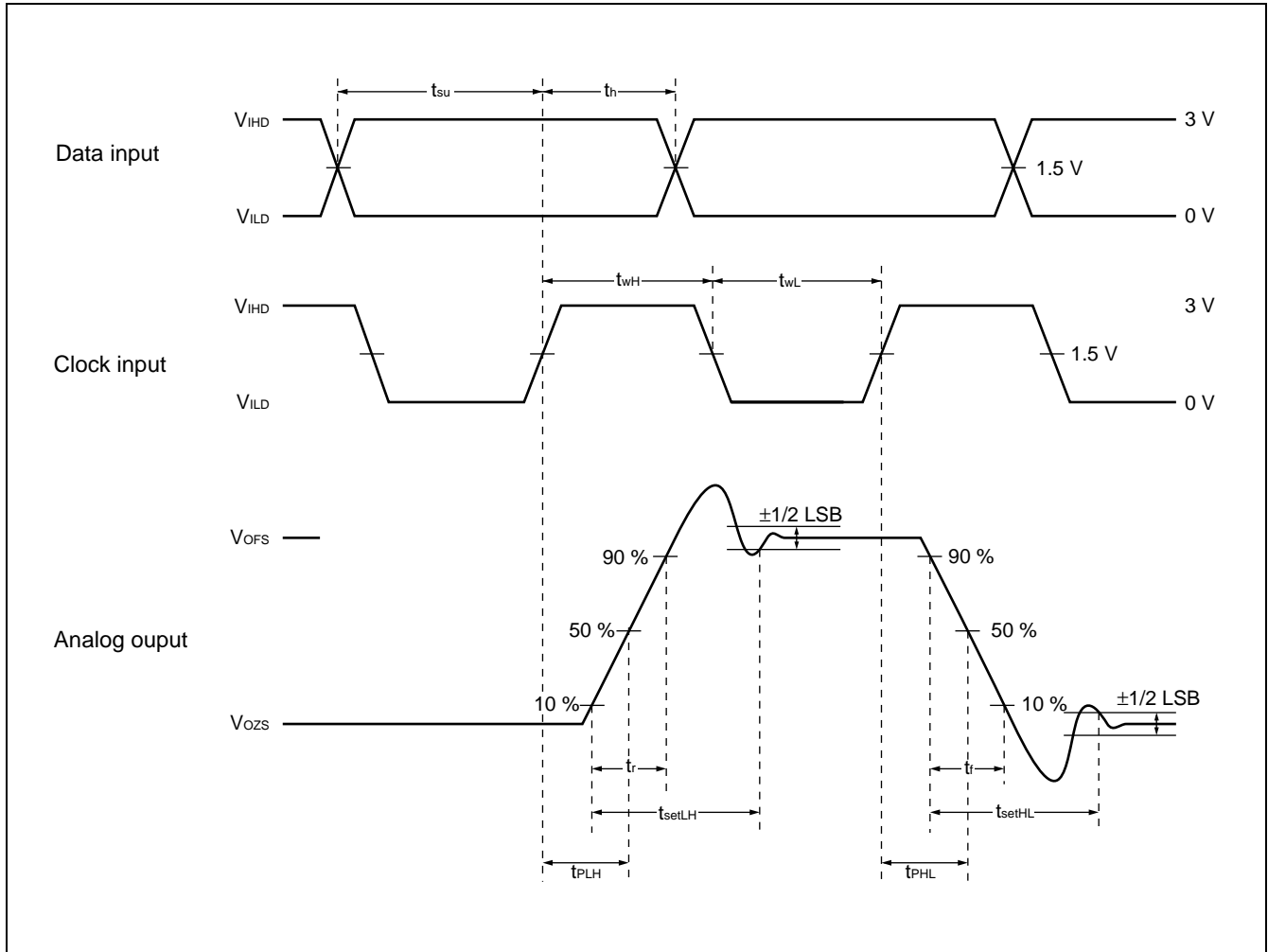

MB40760

■ DAC OUTPUT VOLTAGE CHARACTERISTICS

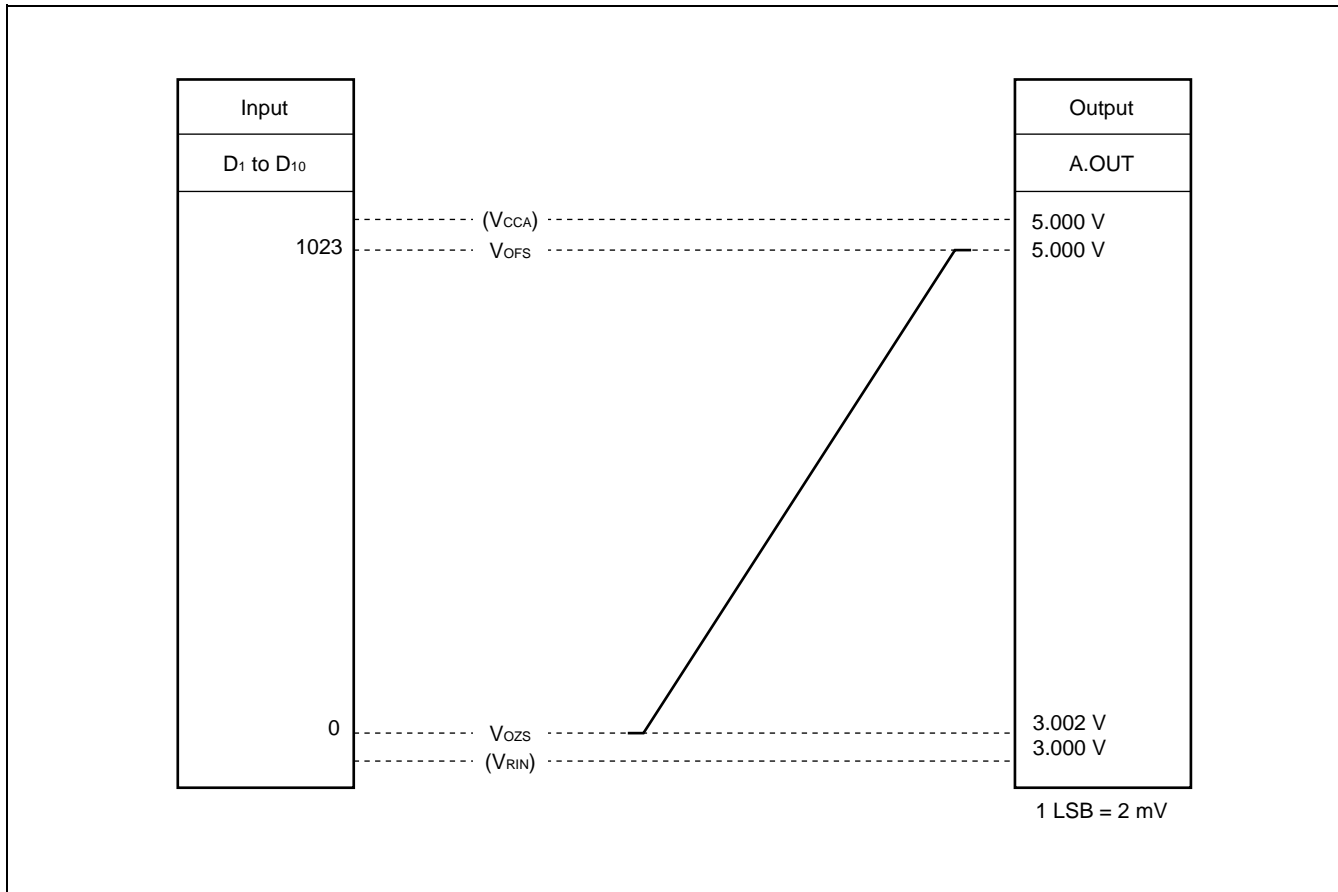

■ DAC OUTPUT VOLTAGE FORMULA IN IDEAL CONDITIONS

$$A.OUT = V_{CCA} - \frac{1023 - N}{1024} (V_{CCA} - V_{RIN})$$

(N: Digital input from 0 to 1023)

$$V_{OFS} = V_{CCA}$$

$$V_{OZS} = V_{CCA} - \frac{1023}{1024} (V_{CCA} - V_{RIN})$$

Notes:

1. Preventing Switching Noise
To prevent switching noise in the analog output signal, connect noise limiting capacitors to the V_{CCA} and V_{CCD} pins as close to the A.GND and D.GND pins as possible.
2. Power Pattern
To reduce parasitic impedance, the PC board pattern to the V_{CCA}, V_{CCD}, A.GND and D.GND pins should be as wide as possible.

MB40760

■ TYPICAL CHARACTERISTICS CURVES

1. Power Supply Current v.s. Ambient Temperature

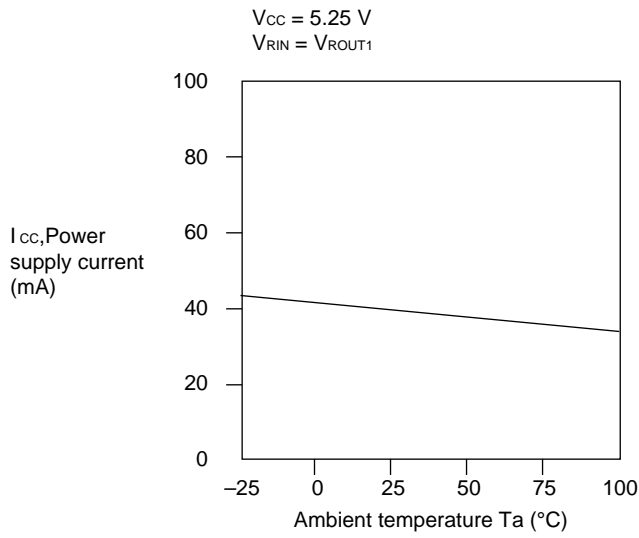

2. Linearity Error v.s. Ambient Temperature

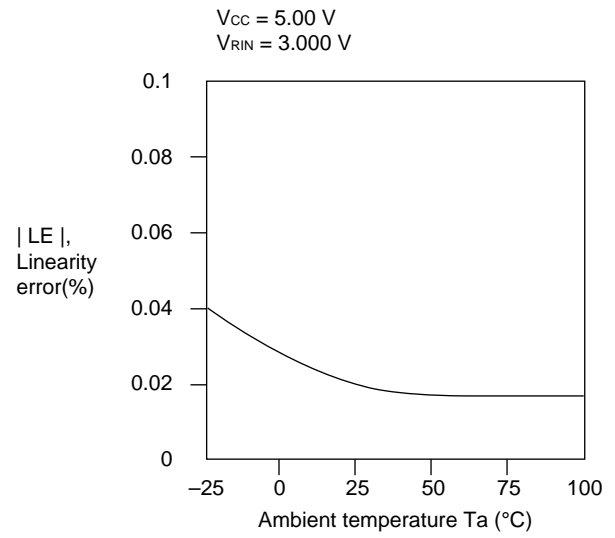

3. Differential Linearity Error v.s. Ambient Temperature

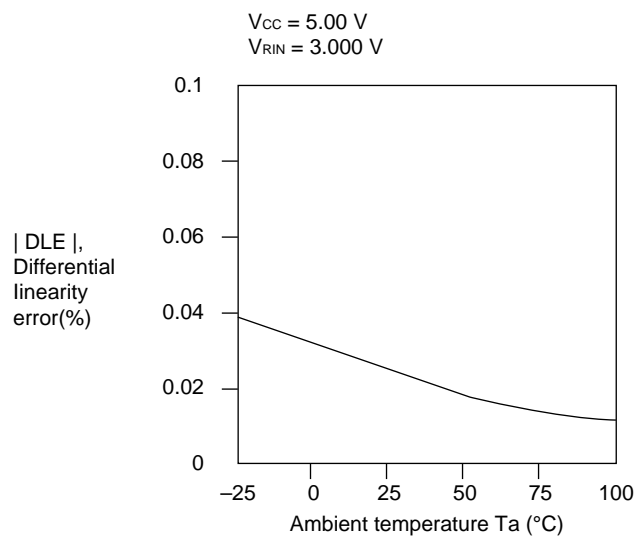

4. Output Resistance v.s. Ambient Temperature

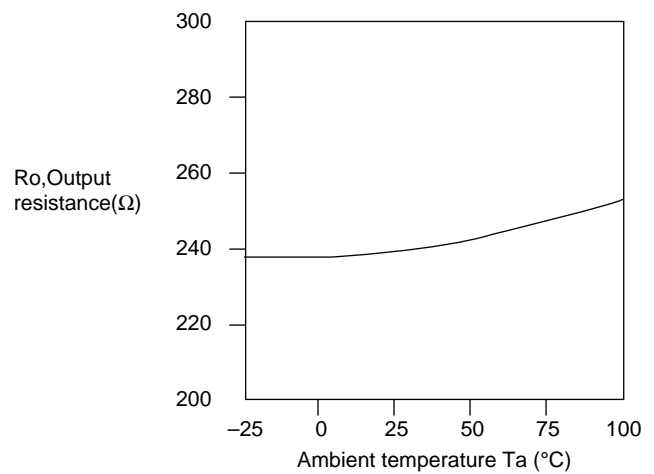

MB40760

5. Full-Scale Output Voltage v.s. Ambient Temperature

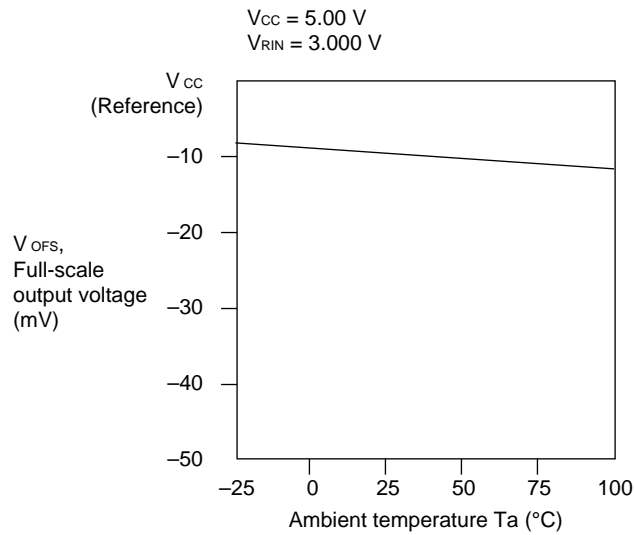

6. Zero-Scale Output Voltage v.s. Ambient Temperature

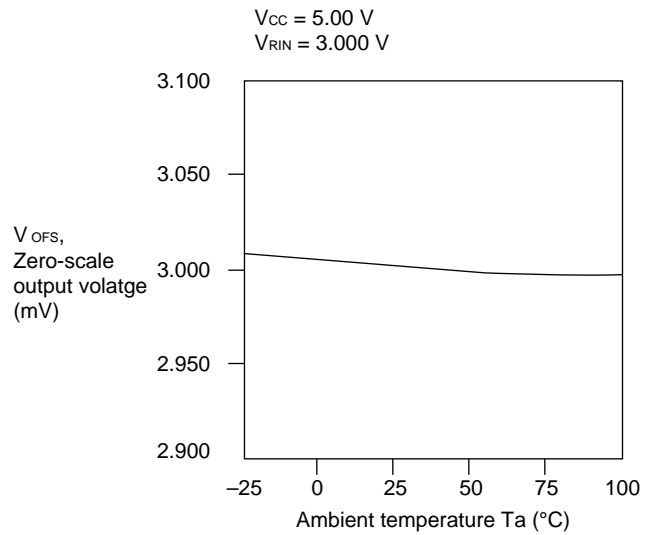

7. V_{ROUT1} Reference Output Voltage v.s. Ambient Temperature

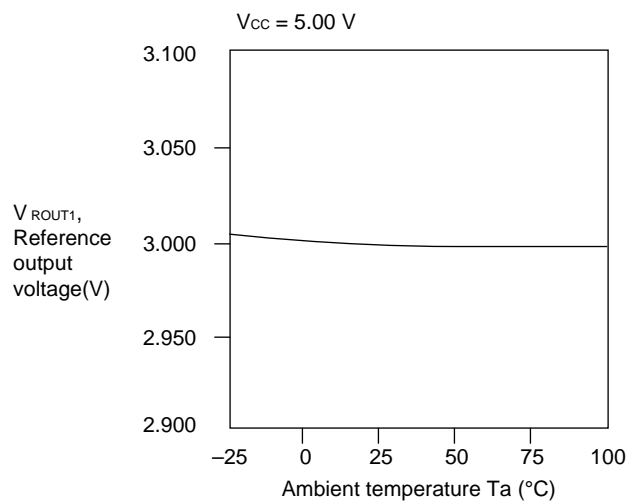

8. V_{ROUT2} Reference Output Voltage v.s. Ambient Temperature

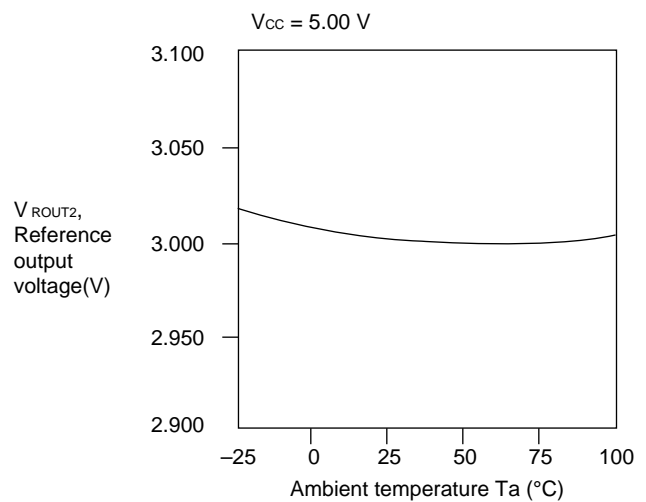

MB40760

9. V_{ROUT2} Reference Output Voltage v.s. Power Supply Voltage

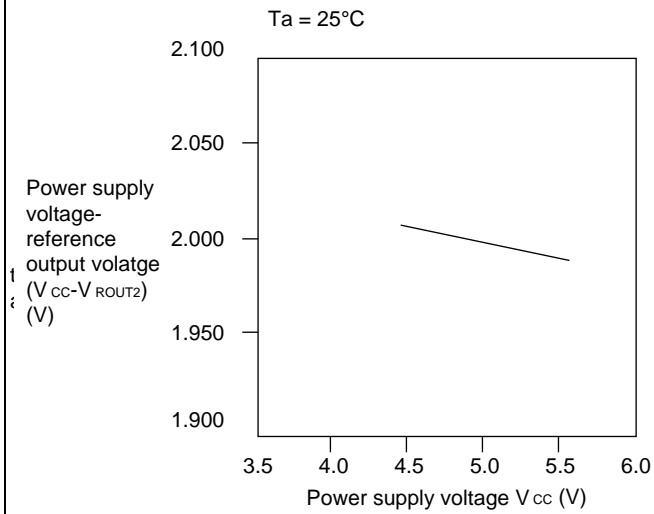

10. Setup Time v.s. Ambient Temperature

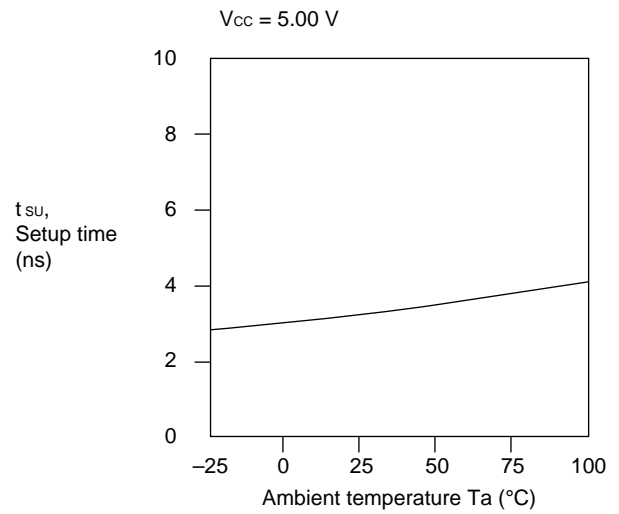

11. Setup Time v.s. Power Supply Voltage

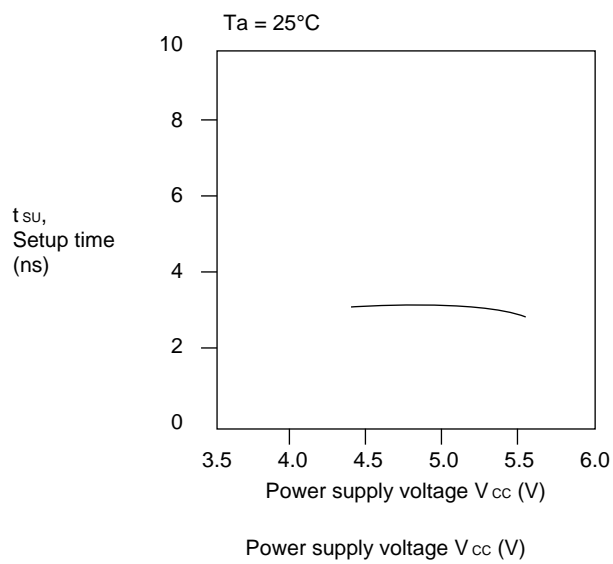

12. Hold Time v.s. Ambient Temperature

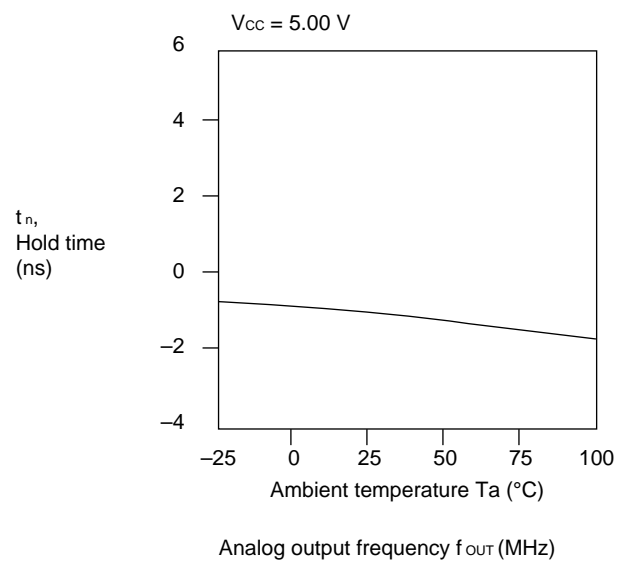

MB40760

13. Hold Time v.s. Power Supply Voltage

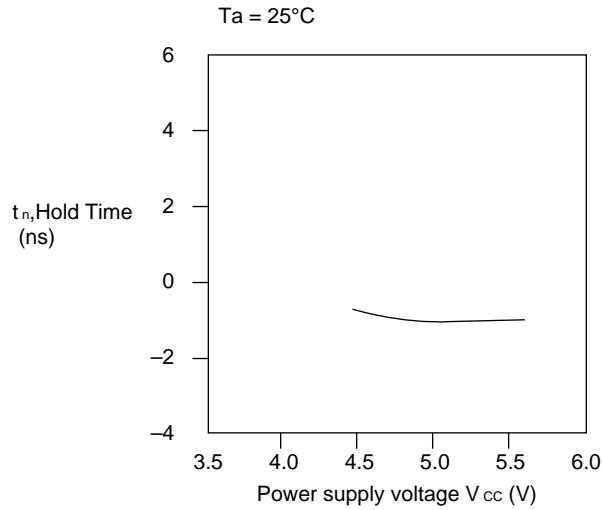

14. Minimum Clock Pulse Width v.s. Ambient Temperature

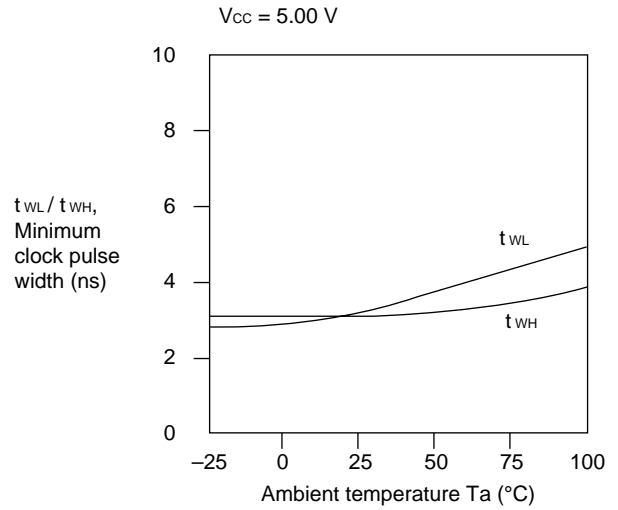

15. Minimum Clock Pulse Width v.s. Power Supply Voltage

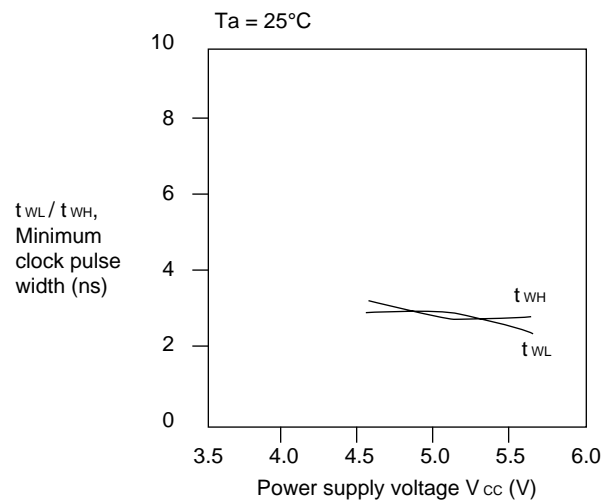

16. Rise Time / Fall Time v.s. Ambient Temperature

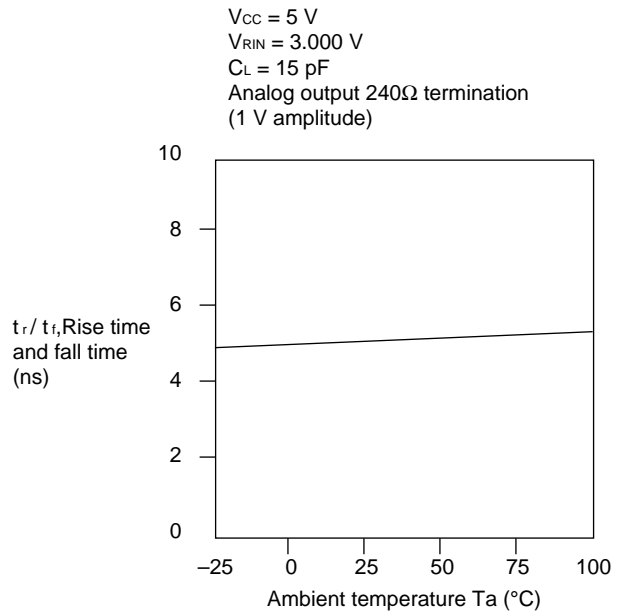

MB40760

17. Rise Time / Fall Time v.s. Power Supply Voltage

Ta = 25°C
 V_{RIN} = 3.000 V
 C_L = 15 pF
 Analog output 240Ω termination
 (1 V amplitude)

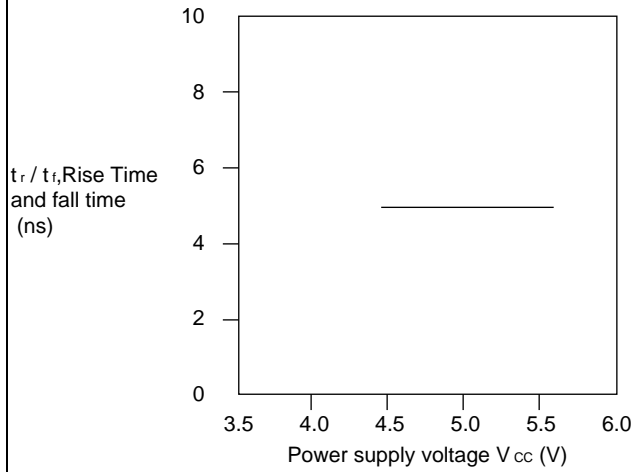

18. Delay Time v.s. Ambient Temperature

V_{CC} = 5.00 V
 V_{RIN} = 3.000 V
 C_L = 15 pF
 Analog output 240Ω termination
 (1 V amplitude)

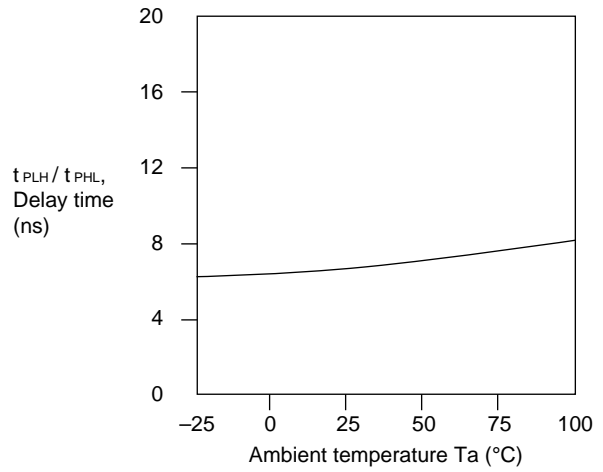

19. Delay Time v.s. Power Supply Voltage

Ta = 25°C
 V_{RIN} = 3.000 V
 C_L = 15 pF
 Analog output 240Ω termination
 (1 V amplitude)

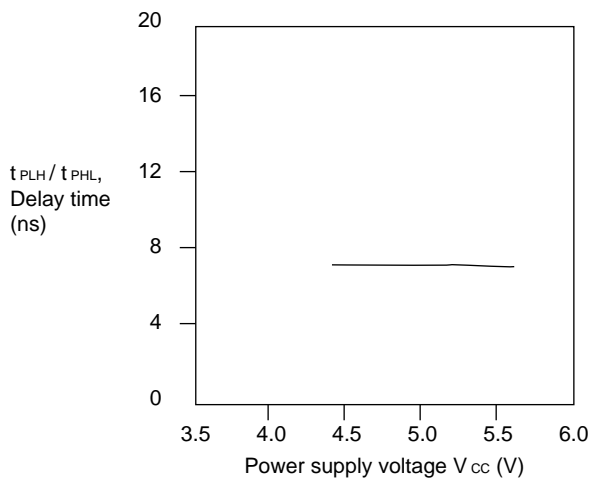

20. Quantization Noise v.s. Analog Output Frequency

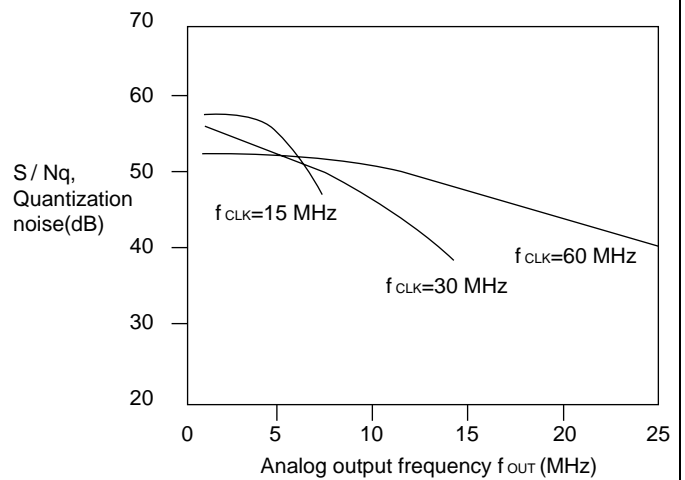

MB40760

■ PACKAGE DIMENSIONS

Plastic DIP, 20 pin
(DIP-20P-M01)

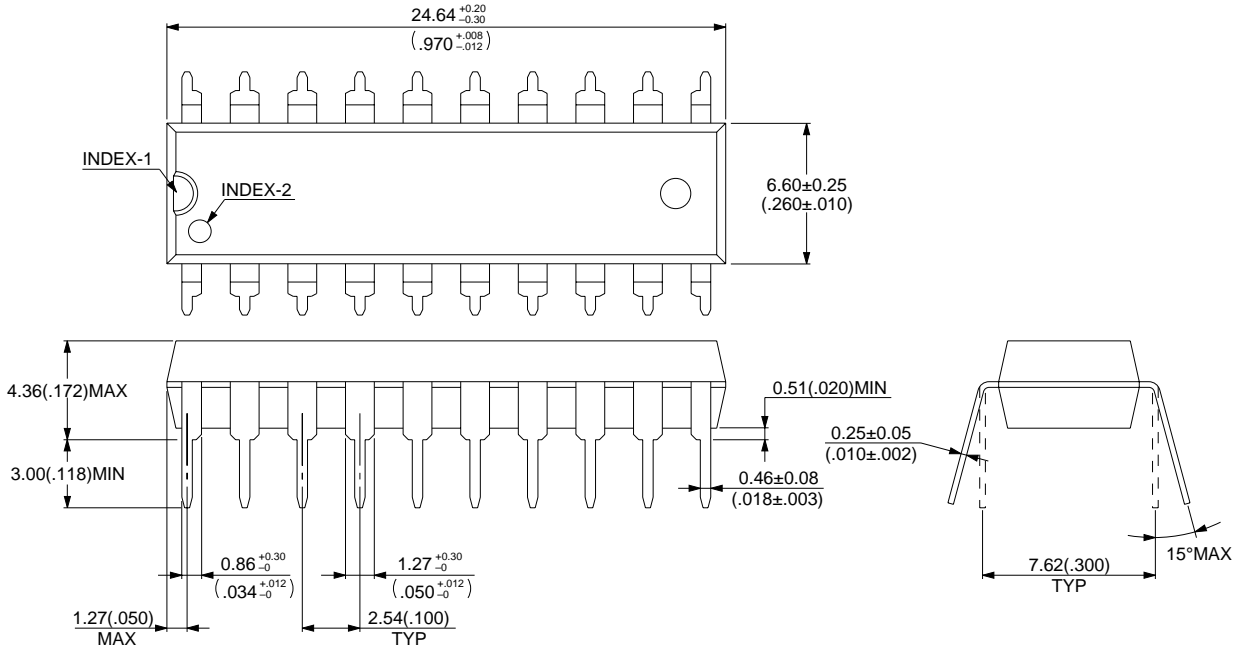

© 1994 FUJITSU LIMITED D20005S-3C-3

Dimensions in mm (inch)

MB40760

Plastic SOP, 20 pin
(FPT-20P-M01)

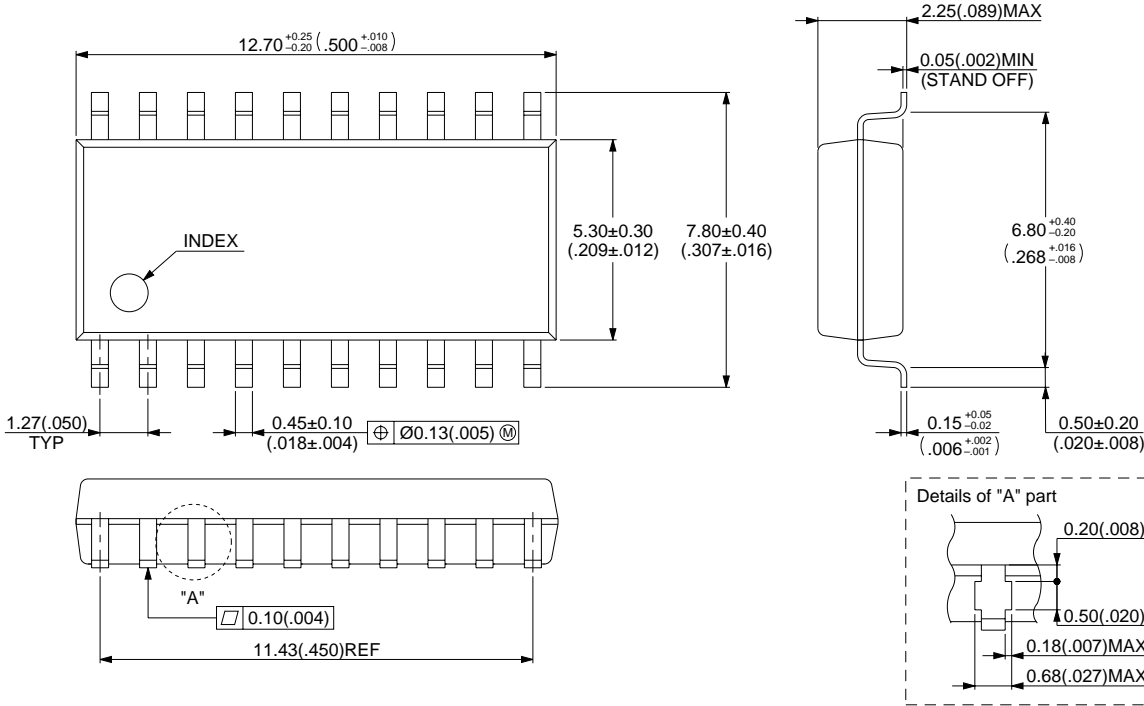

© 1994 FUJITSU LIMITED F20003S-5C-4

Dimensions in mm (inch)

MB40760

FUJITSU LIMITED

For further information please contact:

Japan

FUJITSU LIMITED
Corporate Global Business Support Division
Electronic Devices
KAWASAKI PLANT, 4-1-1, Kamikodanaka
Nakahara-ku, Kawasaki-shi
Kanagawa 211-8588, Japan
Tel: (044) 754-3763
Fax: (044) 754-3329

<http://www.fujitsu.co.jp/>

North and South America

FUJITSU MICROELECTRONICS, INC.
Semiconductor Division
3545 North First Street
San Jose, CA 95134-1804, USA
Tel: (408) 922-9000
Fax: (408) 922-9179

Customer Response Center
Mon. - Fri.: 7 am - 5 pm (PST)
Tel: (800) 866-8608
Fax: (408) 922-9179

<http://www.fujitsumicro.com/>

Europe

FUJITSU MIKROELEKTRONIK GmbH
Am Siebenstein 6-10
D-63303 Dreieich-Buchsschlag
Germany
Tel: (06103) 690-0
Fax: (06103) 690-122

<http://www.fujitsu-edc.com/>

Asia Pacific

FUJITSU MICROELECTRONICS ASIA PTE LTD
#05-08, 151 Lorong Chuan
New Tech Park
Singapore 556741
Tel: (65) 281-0770
Fax: (65) 281-0220

<http://www.fmap.com.sg/>

F9803

© FUJITSU LIMITED Printed in Japan

All Rights Reserved.

The contents of this document are subject to change without notice. Customers are advised to consult with FUJITSU sales representatives before ordering.

The information and circuit diagrams in this document presented as examples of semiconductor device applications, and are not intended to be incorporated in devices for actual use. Also, FUJITSU is unable to assume responsibility for infringement of any patent rights or other rights of third parties arising from the use of this information or circuit diagrams.

FUJITSU semiconductor devices are intended for use in standard applications (computers, office automation and other office equipment, industrial, communications, and measurement equipment, personal or household devices, etc.).

CAUTION:

Customers considering the use of our products in special applications where failure or abnormal operation may directly affect human lives or cause physical injury or property damage, or where extremely high levels of reliability are demanded (such as aerospace systems, atomic energy controls, sea floor repeaters, vehicle operating controls, medical devices for life support, etc.) are requested to consult with FUJITSU sales representatives before such use. The company will not be responsible for damages arising from such use without prior approval.

Any semiconductor devices have inherently a certain rate of failure. You must protect against injury, damage or loss from such failures by incorporating safety design measures into your facility and equipment such as redundancy, fire protection, and prevention of over-current levels and other abnormal operating conditions.

If any products described in this document represent goods or technologies subject to certain restrictions on export under the Foreign Exchange and Foreign Trade Control Law of Japan, the prior authorization by Japanese government should be required for export of those products from Japan.