

# 16 × 32 dot matrix unit

## LUM-512HML300

The LUM-512HML300 is a 16 × 32 dot matrix display which can be used in a wide range of applications, including alphabet, numeric, symbol and graphical displays. A large display can be easily created by arranging a number of these dot matrix displays in an array, and they can be applied to a variety of display purposes. A custom LSI controller has display data memory for two screens, and data for each screen can be written and displayed in turn.

### ●Applications

Light source for displays

### ●Feature

- 1) 16 × 32 dot matrix  
Shape of emitting section: □2.1 × 2.3
- 2) Dimensions: 64mm × 128mm
- 3) Clear display.
- 4) Three-color display is possible (red, green, and orange).
- 5) 1/16 duty dynamic scan method.
- 6) Ultra-thin shape of 9.1mm, light weight of 90g, and wide directional characteristics of 100 degrees.

### ●Specifications

For detailed specifications, refer to pages 286 to 293.

### ●External dimensions(Units: mm)

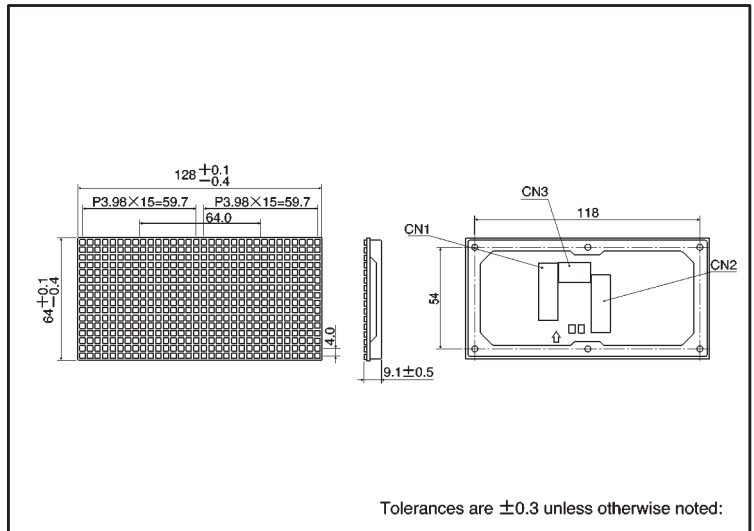

### ●Selection guide

Display Type	Chip LED
Type	LUM-512HML300