

<b>SANYO</b>	No. ※3966A	<b>LC573404A, 573406A</b>
		<b>4-bit Single Chip Microcomputer with LCD Driver</b>

Preliminary

## OVERVIEW

The LC573404A and LC573406A are low-power 4-bit microcontrollers with built-in 4- and 6-Kbyte ROMs, respectively.

They incorporate a 120-segment LCD driver, RAM, a 4-bit parallel-processing ALU, a 16-bit timer and a carrier output for infrared remote control applications.

The LC573404A and LC573406A are ideal for use in battery-operated measuring instruments, products that require timing functions, and LCD and remote controller applications.

The LC573404A and LC573406A operate from a 2.3 to 6.0 V supply and are available in 64-pin QFPs and as dice.

## FEATURES

- 1) ROM
  - 6 Kbytes (LC573406A)
  - 4 Kbytes (LC573404A)
- 2) RAM
  - 512-bit (128 × 4)
- 3) 4-bit parallel-processing ALU
- 4) 120-segment LCD controller/driver
  - 30 segment outputs
  - Four common outputs
    - 120-segment capability when using 1/4 duty
    - 90-segment capability when using 1/3 duty
    - 60-segment capability when using 1/2 duty
    - 30-segment capability when using static drive

SEG16 to SEG30 can be used as normal, p-channel open-drain output ports.
- 5) 16-bit software-controllable timer
- 6) 455 kHz ceramic resonator timebase
  - Configurable as a 15-bit free-running timer
  - 108 ms HALT-mode cancel signal output
- 7) HALT mode
  - Reduces current consumption.
  - Suspends program execution.
  - Exited by a system reset or the HALT-mode cancel signal.
- 8) STOP mode
  - Stops the ceramic resonator oscillator.
  - Exited by a system reset or under program control.

9) HOLD mode

- Stops the ceramic resonator oscillator.
- Exited by a system reset or a HIGH level on ports S or M.

10) Two-level subroutine stack

11) Cycle Time

- 17.6  $\mu$ s and 122  $\mu$ s cycle times at  $f = 455$  kHz and 32.768 kHz, respectively

12) Software-controllable remote control carrier signal generator

- Software-controllable frequency and duty cycle
- 1 to 200 kHz
- Three fixed waveforms
  - 38 kHz with 1/3 duty
  - 38 kHz with 1/2 duty
  - 57 kHz with 1/2 duty

13) Built-in ceramic and crystal oscillators

14) Ports

- Two 4-bit keyscan input ports
- Two 4-bit keyscan output ports
- One 2-bit keyscan expansion or LED driver port

15) Voltage

- 2.3 to 6.0 V supply voltage

16) Factory shipment

- 64-pin QFP and 66-pad die

PINOUT

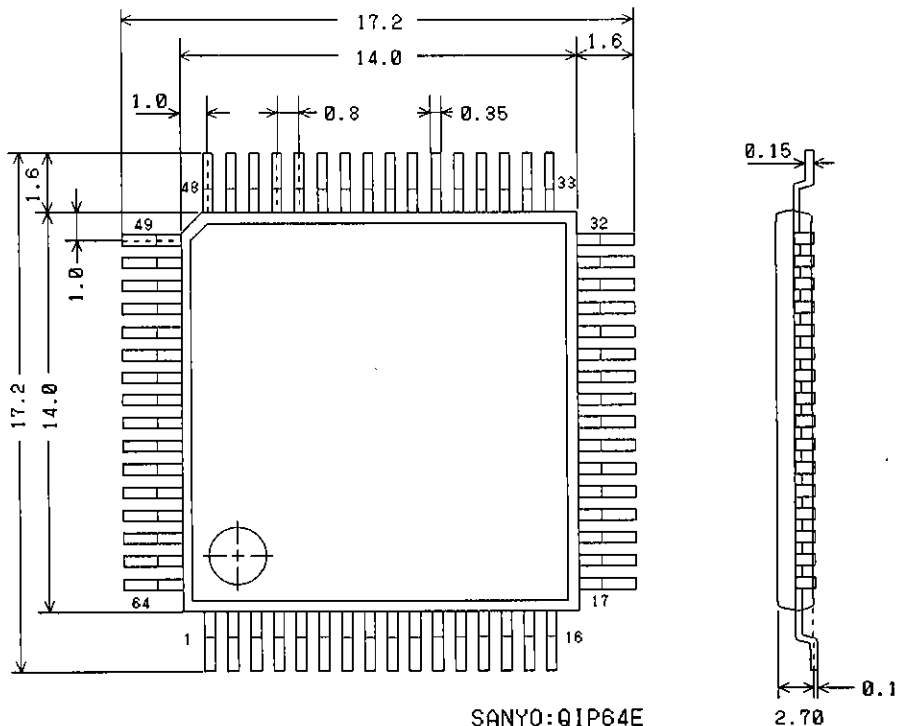

Do not use a soldering iron when mounting the package.

# LC573404A, 573406A

## DIE SPECIFICATIONS

Chip size : 3.89 mm × 3.59 mm  
 Pad size : 120 μm × 120 μm  
 Chip thickness : 480 μm

## Pad Layout

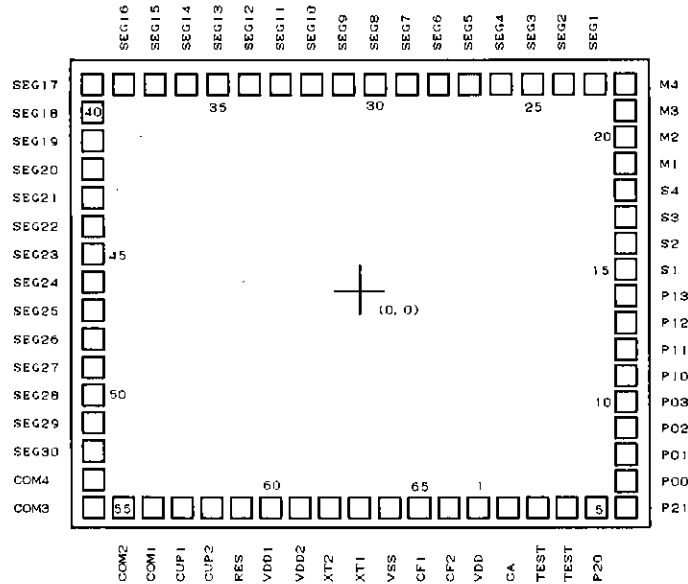

## Pin Assignment of Package

Chip thickness : 330 μm

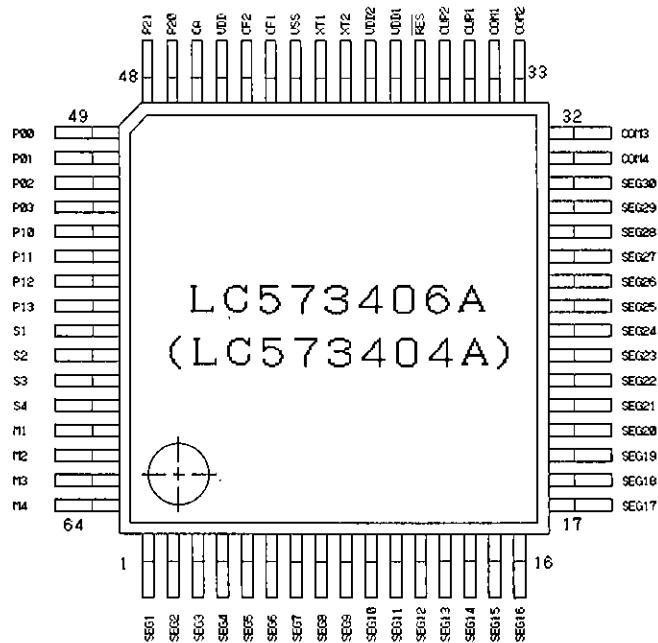

SANYO: QIP64E

## Pad Coordinates

QFP64 Pin No	pad No.	Pad Name	X ( $\mu\text{m}$ )	Y ( $\mu\text{m}$ )	QFP64 Pin No	pad No.	Pad Name	X ( $\mu\text{m}$ )	Y ( $\mu\text{m}$ )
45	1	VDD	720	-1530	14	36	SEG14	-1210	1600
46	2	CA	975	-1530	15	37	SEG15	-1390	1600
-	3	TEST	1155	-1530	16	38	SEG16	-1570	1600
-	4	TEST	1335	-1530	17	39	SEG17	-1750	1600
47	5	P20	1515	-1530	18	40	SEG18	-1750	1385
48	6	P21	1700	-1530	19	41	SEG19	-1750	1205
49	7	P00	1690	-1170	20	42	SEG20	-1750	1025
50	8	P01	1690	-990	21	43	SEG21	-1750	845
51	9	P02	1690	-810	22	44	SEG22	-1750	665
52	10	P03	1690	-630	23	45	SEG23	-1750	485
53	11	P10	1690	-450	24	46	SEG24	-1750	305
54	12	P11	1690	-270	25	47	SEG25	-1750	125
55	13	P12	1690	-90	26	48	SEG26	-1750	-55
56	14	P13	1690	90	27	49	SEG27	-1750	-235
57	15	S1	1690	310	28	50	SEG28	-1750	-415
58	16	S2	1690	490	29	51	SEG29	-1750	-595
59	17	S3	1690	670	30	52	SEG30	-1750	-775
60	18	S4	1690	850	31	53	COM4	-1750	-955
61	19	M1	1690	1030	32	54	COM3	-1750	-1530
62	20	M2	1690	1210	33	55	COM2	-1570	-1530
63	21	M3	1690	1390	34	56	COM1	-1390	-1530
64	22	M4	1690	1570	35	57	CUP1	-1160	-1530
1	23	SEG1	1130	1600	36	58	CUP2	-980	-1530
2	24	SEG2	950	1600	37	59	RES	-800	-1530
3	25	SEG3	770	1600	38	60	VDD1	-620	-1530
4	26	SEG4	590	1600	39	61	VDD2	-440	-1530
5	27	SEG5	410	1600	40	62	XT2	-260	-1530
6	28	SEG6	230	1600	41	63	XT1	-80	-1530
7	29	SEG7	50	1600	42	64	VSS	100	-1530
8	30	SEG8	-130	1600	43	65	CF1	360	-1530
9	31	SEG9	-310	1600	44	66	CF2	540	-1530
10	32	SEG10	-490	1600					
11	33	SEG11	-670	1600					
12	34	SEG12	-850	1600					
13	35	SEG13	-1030	1600					

■ No products described or contained herein are intended for use in surgical implants, life-support systems, aerospace equipment, nuclear power control systems, vehicles, disaster/crime-prevention equipment and the like, the failure of which may directly or indirectly cause injury, death or property loss.

■ Anyone purchasing any products described or contained herein for an above-mentioned use shall:

- ① Accept full responsibility and indemnify and defend SANYO ELECTRIC CO., LTD., its affiliates, subsidiaries and distributors and all their officers and employees, jointly and severally, against any and all claims and litigation and all damages, cost and expenses associated with such use;
- ② Not impose any responsibility for any fault or negligence which may be cited in any such claim or litigation on SANYO ELECTRIC CO., LTD., its affiliates, subsidiaries and distributors or any of their officers and employees jointly or severally.

■ Information (including circuit diagrams and circuit parameters) herein is for example only; it is not guaranteed for volume production. SANYO believes information herein is accurate and reliable, but no guarantees are made or implied regarding its use or any infringements of intellectual property rights or other rights of third parties.

BLOCK DIAGRAM

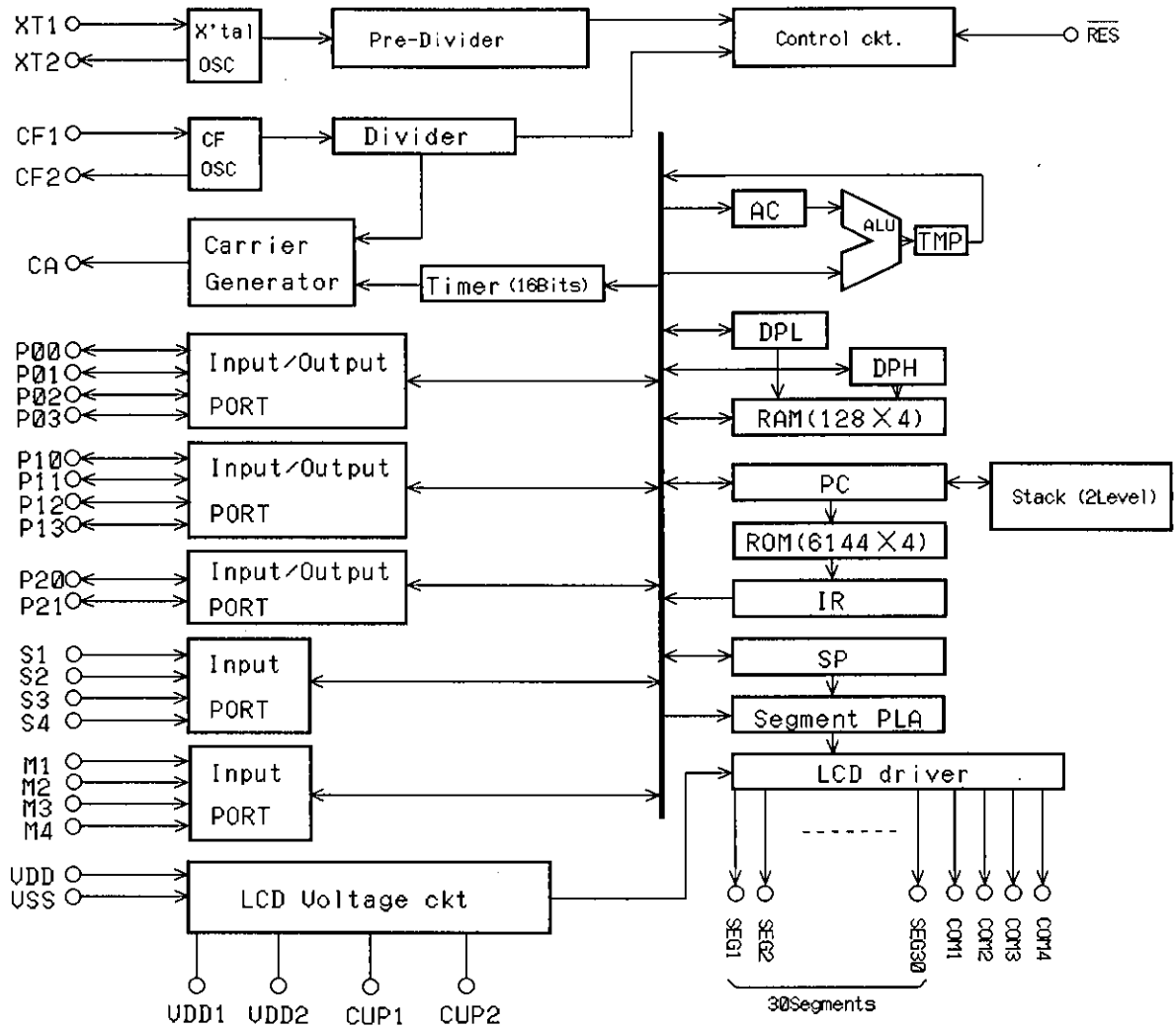

PIN DESCRIPTION

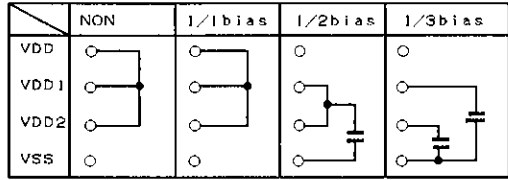
Number		Name	Description
QFP64	Die		
45	1	VDD	Supply voltage. See figure 1.
42	64	VSS	Ground. See figure 1.
38 39	60 61	VDD1 VDD2	LCD driver supply voltage inputs. See figure 1. 
35 36	57 58	CUP1 CUP2	LCD driver external coupling capacitor. A non-polarized capacitor should be connected between CUP1 and CUP2 when using 1/2 or 1/3 bias.
43	65	CF1	455kHz ceramic resonator oscillator input
44	66	CF2	455kHz ceramic resonator oscillator output
41	63	XT1	32.768 kHz crystal oscillator input
40	62	XT2	32.768 kHz crystal oscillator output
57 to 60	15 to 18	S1 to S4	Input port S.
61 to 64	19 to 22	M1 to M4	Input port M
49 to 52	7 to 10	P00 to P03	Bidirectional port P0. P-channel open-drain outputs
53 to 56	11 to 14	P10 to P13	Bidirectional port P1. P-channel open-drain outputs
47 48	5 6	P20 P21	Bidirectional port P2. P-channel open-drain outputs. P20 and P21 can be used to directly drive a LED in remote control applications.

Number		Name	Description																													
QFP64	Die																															
46	2	CA	Remote control carrier output																													
37	59	$\overline{\text{RES}}$	Reset input. Internal pull-up resistor																													
34 33 32 31	56 55 54 53	COM1 COM2 COM3 COM4	<p>LCD common driver outputs. The pins required for the various operating modes are indicated in the following table.</p> <table border="1"> <thead> <tr> <th rowspan="2">Pin</th> <th colspan="4">Duty</th> </tr> <tr> <th>Static (64Hz)</th> <th>1/2 (32Hz)</th> <th>1/3 (42Hz)</th> <th>1/4 (32Hz)</th> </tr> </thead> <tbody> <tr> <td>COM1</td> <td>○</td> <td>○</td> <td>○</td> <td>○</td> </tr> <tr> <td>COM2</td> <td>×</td> <td>○</td> <td>○</td> <td>○</td> </tr> <tr> <td>COM3</td> <td>×</td> <td>×</td> <td>○</td> <td>○</td> </tr> <tr> <td>COM4</td> <td>×</td> <td>×</td> <td>×</td> <td>○</td> </tr> </tbody> </table>	Pin	Duty				Static (64Hz)	1/2 (32Hz)	1/3 (42Hz)	1/4 (32Hz)	COM1	○	○	○	○	COM2	×	○	○	○	COM3	×	×	○	○	COM4	×	×	×	○
Pin	Duty																															
	Static (64Hz)	1/2 (32Hz)	1/3 (42Hz)	1/4 (32Hz)																												
COM1	○	○	○	○																												
COM2	×	○	○	○																												
COM3	×	×	○	○																												
COM4	×	×	×	○																												
1 to 15	23 to 37	SEG1 to SEG15	LCD segment driver outputs																													
16 to 30	38 to 52	SEG16 to SEG30	P-channel open-drain outputs. Configurable as either LCD segment drivers or normal output ports.																													
—	3 4	TEST	Test inputs. Leave open for normal operation.																													

# LC573404A, 573406A

## Supply connections

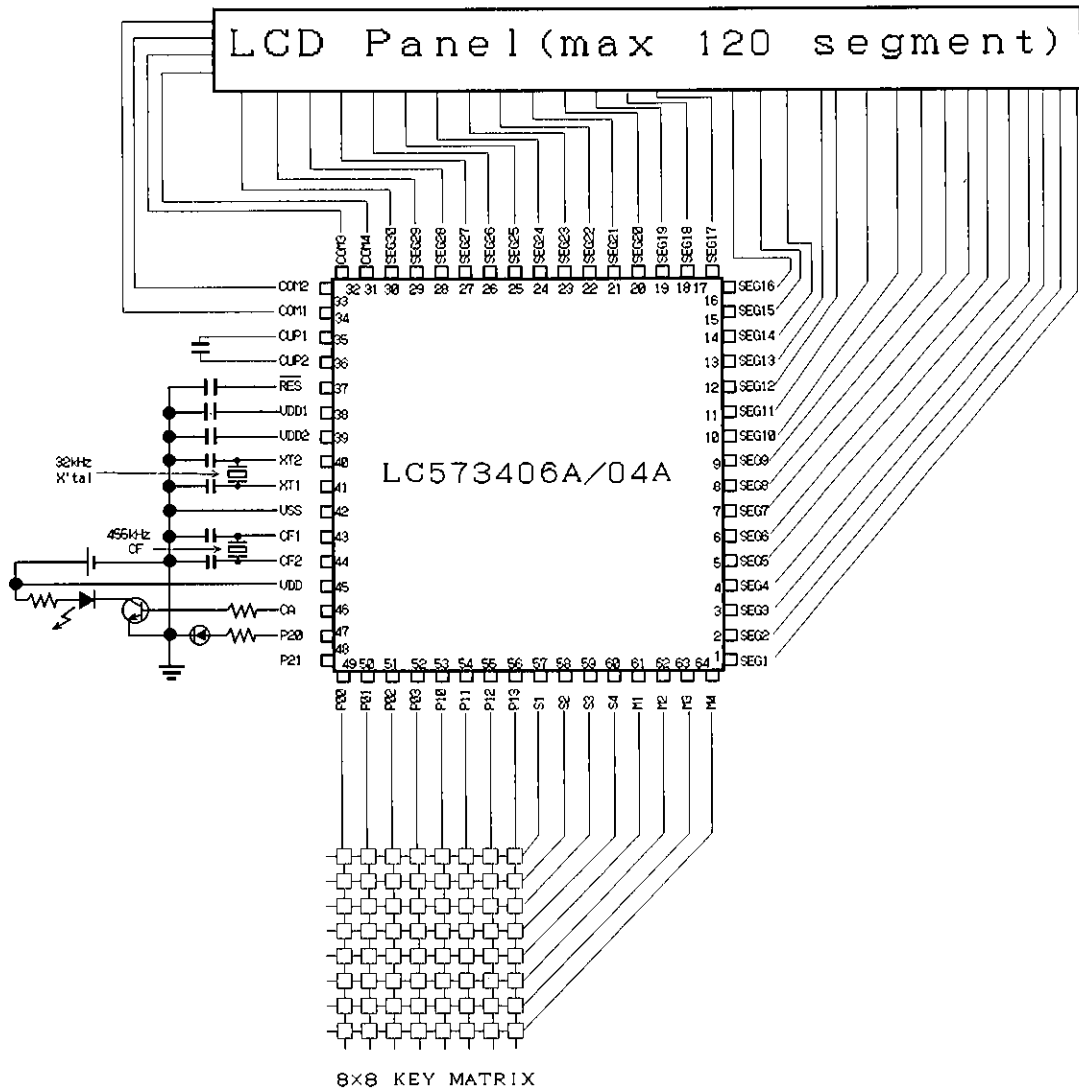

Figure 1. Supply Connections



## SPECIFICATIONS

## Absolute Maximum Ratings

Parameter	Symbol	Rating	Unit
Supply voltage range	$V_{DD}$	-0.3 to 7.0	V
	$V_{DD1}$	-0.3 to $V_{DD}$	V
	$V_{DD2}$	-0.3 to $V_{DD}$	V
Input voltage range	$V_I$	-0.3 to $V_{DD}+0.3$	V
Output voltage range	$V_O$	-0.3 to $V_{DD}+0.3$	V
CA output current	$I_{O1}$	25	mA
Ports P0 and P1 output current	$I_{O2}$	0.5	mA
Port P2 output current	$I_{O3}$	10	mA
Output current for all other ports	$I_{O4}$	0.5	mA
Total output current of all pins except CA	$I_{O5}$	25	mA
Operating temperature range	$T_{opr}$	-30 to 70	°C
Storage temperature range	$T_{stg}$	-40 to 125	°C

## Recommended Operating Conditions

$V_{SS} = 0$  V,  $T_a = 25$  °C

Parameter	Symbol	Rating	Unit
Supply voltage	$V_{DD}$	3	V
Supply voltage range	$V_{DD}$	2.3 to 6.0	V

Electrical Characteristics  
 $V_{SS} = 0\text{ V}$ ,  $T_a = -30\text{ to }70\text{ }^\circ\text{C}$

Parameter	Symbol	Condition	Rating			Unit	
			VDD (V)	min	typ		max
Operating Current	$I_{DD}$	$f = 32.768\text{ kHz}$ , $C1 = C2 = 0.1\text{ }\mu\text{F}$ , $C_G = C_D = 20\text{ pF}$ , $T_a \leq 50\text{ }^\circ\text{C}$ , oscillator stopped. See note 3.	3.0	-	7	30	$\mu\text{A}$
			5.0	-	15	50	
		$f = 455\text{ kHz}$ , $C1 = C2 = 0.1\text{ }\mu\text{F}$ , $C_{CD} = C_{CC} = 150\text{ pF}$ , $T_a \leq 50\text{ }^\circ\text{C}$ , oscillator stopped. See note 4.	3.0	-	150	500	
			5.0	-	400	500	

Notes

1. Configured as LCD driver outputs.
2. Configured as p-channel open-drain outputs.
3. The measurement circuit for static drive, 1/2 or 1/3 bias is shown in figures 6, 7 and 8, respectively.
4. The measurement circuit for static drive, 1/2 or 1/3 bias is shown in figures 9, 10 and 11, respectively.
5. The measurement circuit for static drive, 1/2 or 1/3 bias is shown in figures 5, 3 and 4, respectively.

Parameter	Symbol	Condition	Rating			Unit	
			VDD(V)	min	typ		max
HALT-mode supply Current	I <sub>DDH1</sub>	f = 32.768 kHz, C <sub>1</sub> = C <sub>2</sub> = 0.1 μF, C <sub>G</sub> = C <sub>D</sub> = 20 pF, T <sub>a</sub> ≤ 50 °C, oscillator stopped. See note 3.	3.0	-	3	15	μA
			5.0	-	8	50	
		f = 455 kHz, C <sub>1</sub> = C <sub>2</sub> = 0.1 μF, C <sub>CD</sub> = C <sub>CG</sub> = 150 pF, T <sub>a</sub> ≤ 50 °C, oscillator stopped See note 4.	3.0	-	80	500	
			5.0	-	300	400	
	I <sub>DDH2</sub>	f = 455 kHz, oscillator stopped	5.0	-	0.1	-	

Notes

1. Configured as LCD driver outputs.
2. Configured as p-channel open-drain outputs.
3. The measurement circuit for static drive, 1/2 or 1/3 bias is shown in figures 6, 7 and 8, respectively.
4. The measurement circuit for static drive, 1/2 or 1/3 bias is shown in figures 9, 10 and 11, respectively.
5. The measurement circuit for static drive, 1/2 or 1/3 bias is shown in figures 5, 3 and 4, respectively.

Parameter	Symbol	Condition	Rating			Unit
			min	typ	max	
Instruction execution time	$t_{cyc}$	$V_{DD} = 2.3$ to $6.0$ , Ceramic resonator, $f = 455$ kHz	-	17.6	-	$\mu S$
		$V_{DD} = 2.3$ to $6.0$ , crystal oscillator $f = 32.768$ kHz	-	122	-	
Ports S, M, P0, P1 and P2 LOW-level input voltage	$V_{IL1}$	Ports P0, P1 and P2 configured as inputs	0	-	$0.3V_{DD}$	V
Ports S, M, P0, P1 and P2 HIGH-level input voltage	$V_{IH1}$	Ports P0, P1 and P2 configured as inputs	$0.7V_{DD}$	-	$V_{DD}$	V
RES LOW-level input voltage	$V_{IL2}$		0	-	$0.25V_{DD}$	V
RES HIGH-level input voltage	$V_{IH2}$		$0.75V_{DD}$	-	$V_{DD}$	V

## Notes

1. Configured as LCD driver outputs.
2. Configured as p-channel open-drain outputs.
3. The measurement circuit for static drive, 1/2 or 1/3 bias is shown in figures 6, 7 and 8, respectively.
4. The measurement circuit for static drive, 1/2 or 1/3 bias is shown in figures 9, 10 and 11, respectively.
5. The measurement circuit for static drive, 1/2 or 1/3 bias is shown in figures 5, 3 and 4, respectively.

Parameter	Symbol	Condition	V <sub>DD</sub> (V)	Rating			Unit
				min	typ	max	
Ports S and M input impedance	R <sub>I1</sub>	V <sub>IL</sub> = 0.4 V, LOW-level hold transistor ON. See figure 2.	2.9	150	300	1000	kΩ
			5.0	70	200	600	
	R <sub>I2</sub>	V <sub>IL</sub> = 0.4 V, LOW-level pull- down transistor ON See figure 2.	2.9	60	100	150	kΩ
			5.0	60	100	150	
RES input imped- ance	R <sub>I3</sub>		2.9	10	-	300	kΩ
			5.0	10	-	300	
SEG1 to SEG30 MID-level output voltage	V <sub>OM1</sub>	I <sub>OL</sub> = 0.4 μA, I <sub>OH</sub> = -0.4 μA, 1/3 bias	2.9	2V <sub>DD</sub> /3 - 0.2	-	2V <sub>DD</sub> /3 + 0.2	V
			5.0	2V <sub>DD</sub> /3 - 0.2	-	2V <sub>DD</sub> /3 + 0.2	
	V <sub>OM1-1</sub>	See note 1.	2.9	V <sub>DD</sub> /3 - 0.2	-	V <sub>DD</sub> /3 + 0.2	V
			5.0	V <sub>DD</sub> /3 - 0.2	-	V <sub>DD</sub> /3 + 0.2	
	V <sub>OM1-2</sub>	I <sub>OL</sub> = 0.4 μA, See note 1.	2.9	-	-	0.2	V
			5.0	-	-	0.2	
SEG1 to SEG30 HIGH-level output voltage	V <sub>OH1</sub>	I <sub>OH</sub> = -0.4 μA, See note 1.	2.9	V <sub>DD</sub> -0.2	-	-	V
			5.0	V <sub>DD</sub> -0.2	-	-	
	V <sub>OH2</sub>	I <sub>OH</sub> = -45 μA, See note 2.	2.9	V <sub>DD</sub> -0.45	-	-	V
			5.0	V <sub>DD</sub> -0.75	-	-	

## Notes

1. Configured as LCD driver outputs.
2. Configured as p-channel open-drain outputs.
3. The measurement circuit for static drive, 1/2 or 1/3 bias is shown in figures 6, 7 and 8, respectively.
4. The measurement circuit for static drive, 1/2 or 1/3 bias is shown in figures 9, 10 and 11, respectively.
5. The measurement circuit for static drive, 1/2 or 1/3 bias is shown in figures 5, 3 and 4, respectively.

Parameter	Symbol	Condition	Rating			Unit	
			V <sub>DD</sub> (V)	min	typ		max
SEG1 to SEG30 LOW-level leakage current	I <sub>LL1</sub>	V <sub>I</sub> = V <sub>SS</sub> , See note 2.	2.9	-	-	1	μA
			5.0	-	-	1	
SEG1 to SEG30 HIGH-level leakage current	I <sub>LH1</sub>	V <sub>I</sub> = V <sub>DD</sub> , See note 2.	2.9	-1	-	-	μA
			5.0	-1	-	-	
COM1 to COM4 LOW-level output voltage	V <sub>OL1</sub>	I <sub>OL</sub> = 4 μA	2.9	-	-	0.2	V
			5.0	-	-	0.2	
COM1 to COM4 MID-level output voltage	V <sub>OM2-1</sub>	1/2 bias	2.9	V <sub>DD</sub> /2 - 0.2	-	V <sub>DD</sub> /2 + 0.2	V
			5.0	V <sub>DD</sub> /2 - 0.2	-	V <sub>DD</sub> /2 + 0.2	
	V <sub>OM2-2</sub>	1/3 bias, I <sub>OH</sub> = - 4 μA	2.9	2V <sub>DD</sub> /3 - 0.2	-	2V <sub>DD</sub> /3 + 0.2	V
			5.0	2V <sub>DD</sub> /3 - 0.2	-	2V <sub>DD</sub> /3 + 0.2	
	V <sub>OM2-3</sub>	1/3 bias, I <sub>OL</sub> = - 4 μA	2.9	V <sub>DD</sub> /3 - 0.2	-	V <sub>DD</sub> /3 + 0.2	V
			5.0	V <sub>DD</sub> /3 - 0.2	-	V <sub>DD</sub> /3 + 0.2	
COM1 to COM4 HIGH-level output voltage	V <sub>OH3</sub>	I <sub>OL</sub> = - 4 μA	2.9	V <sub>DD</sub> -0.2	-	-	V
			5.0	V <sub>DD</sub> -0.2	-	-	
Ports P0 and P1 HIGH-level output voltage	V <sub>OH4</sub>	I <sub>OH</sub> = -450 μA,	2.9	V <sub>DD</sub> - 0.45	-	-	V
		I <sub>OH</sub> = -500 μA	5.0	V <sub>DD</sub> - 0.50	-	-	

Notes

1. Configured as LCD driver outputs.
2. Configured as p-channel open-drain outputs.
3. The measurement circuit for static drive, 1/2 or 1/3 bias is shown in figures 6, 7 and 8, respectively.
4. The measurement circuit for static drive, 1/2 or 1/3 bias is shown in figures 9, 10 and 11, respectively.
5. The measurement circuit for static drive, 1/2 or 1/3 bias is shown in figures 5, 3 and 4, respectively.

Parameter	Symbol	Condition	Rating			Unit	
			V <sub>DD</sub> (V)	min	typ		max
Ports P0 and P1 LOW-level leakage current	I <sub>LL2</sub>	V <sub>I</sub> = V <sub>SS</sub> ,	2.9	-	-	1	μA
			5.0	-	-	1	
Ports P0 and P1 HIGH-LEVEL leakage current	I <sub>LH2</sub>	V <sub>I</sub> = V <sub>DD</sub> ,	2.9	-1	-	-	μA
			5.0	-1	-	-	
Port P2 HIGH-level output voltage	V <sub>OH5</sub>	I <sub>OH</sub> = -1.0 mA,	2.9	V <sub>DD</sub> -0.5	-	-	V
			5.0	V <sub>DD</sub> -0.5	-	-	
Port P2 LOW-level leakage current	I <sub>LL3</sub>	V <sub>I</sub> = V <sub>SS</sub> ,	2.9	-	-	1	μA
			5.0	-	-	1	
Port P2 HIGH-level leakage current	I <sub>LH3</sub>	V <sub>I</sub> = V <sub>DD</sub> ,	2.9	-1	-	-	μA
			5.0	-1	-	-	
CA LOW-level output current	I <sub>OL1</sub>	V <sub>OL</sub> = 0.9 V,	3.0	2	5	-	mA
			5.0	2	5	-	
CA HIGH-level output current	I <sub>OH1</sub>	V <sub>OH</sub> = V <sub>DD</sub> - 1.5 V,	3.0	6	12	-	mA
		V <sub>OH</sub> = V <sub>DD</sub> - 2.5 V,	5.0	10	20	-	
V <sub>DD1</sub> output voltage	V <sub>DD1-1</sub>	C1 =C2 = 0.1 μF, f =32.768 kHz, 1/2 bias. See figure 3	3.0	1.3	1.5	1.7	V
			5.0	2.4	2.5	2.6	
V <sub>DD1</sub> - V <sub>DD2</sub> voltage differential	V <sub>DD1-2</sub>	C1 =C2 = 0.1 μF, f =32.768 kHz, 1/3 bias. See figure 4	3.0	1.8	2.0	2.2	V
			5.0	3.1	3.33	3.5	

Notes

1. Configured as LCD driver outputs.
2. Configured as p-channel open-drain outputs.
3. The measurement circuit for static drive, 1/2 or 1/3 bias is shown in figures 6, 7 and 8, respectively.
4. The measurement circuit for static drive, 1/2 or 1/3 bias is shown in figures 9, 10 and 11, respectively.
5. The measurement circuit for static drive, 1/2 or 1/3 bias is shown in figures 5, 3 and 4, respectively.

Parameter	Symbol	Condition		Rating			Unit	
				V <sub>DD</sub> (V)	min	typ		max
V <sub>DD2</sub> output voltage	V <sub>DD2</sub>	C1 = C2 = 0.1 μF, f = 32.768 kHz, 1/3 bias. See figure 4	3.0	0.8	1.0	1.2	V	
			5.0	1.4	1.67	1.8		
Power supply leakage current	I <sub>LK</sub>	ceramic resonator	Ta = 25 °C	3.0	-	0.2	1	μA
			5.0	-	0.2	1		
		Ta = 50 °C	3.0	-	1	5		
			5.0	-	1	5		
Oscillator start-up voltage	V <sub>ST</sub>	Crystal oscillator, f = 32.768 kHz, C <sub>G</sub> = C <sub>D</sub> = 20 pF, See note 5.		-	-	2.3	V	
		Ceramic resonator, f = 455 kHz, C <sub>CD</sub> = C <sub>CG</sub> = 150 pF, See note 5.		-	-	2.3		
Oscillator sustaining voltage	V <sub>SUS</sub>	Crystal oscillator, f = 32.768 kHz, C <sub>G</sub> = C <sub>D</sub> = 20 pF, See note 5.		2	-	-	V	
		Ceramic resonator, f = 455 kHz, C <sub>CD</sub> = C <sub>CG</sub> = 150 pF, See note 5.		2	-	-		

Notes

1. Configured as LCD driver outputs.
2. Configured as p-channel open-drain outputs.
3. The measurement circuit for static drive, 1/2 or 1/3 bias is shown in figures 6, 7 and 8, respectively.
4. The measurement circuit for static drive, 1/2 or 1/3 bias is shown in figures 9, 10 and 11, respectively.
5. The measurement circuit for static drive, 1/2 or 1/3 bias is shown in figures 5, 3 and 4, respectively.



Parameter	Symbol	Condition	Rating			Unit
			min	typ	max	
Oscillator start-up time	$t_{ST}$	$V_{DD} = 2.3$ V, crystal oscillator $f = 32.768$ kHz, $C_G = C_D = 20$ pF, See note 5.	-	-	5	s
		$V_{DD} = 2$ V, ceramic resonator, $f = 455$ kHz, $C_{CG} = C_{CD} = 150$ pF. See note 5.	-	-	30	ms
Oscillator operating frequency range	f <sub>opg</sub>	32.768 kHz crystal oscillator See figure 12.	32	32.768	33	kHz
		455 kHz ceramic resonator. See figure 13.	380	455	500	
Crystal oscillator external adjustment capacitor range	$C_D$		16	20	24	pF

## Notes

1. Configured as LCD driver outputs.
2. Configured as p-channel open-drain outputs.
3. The measurement circuit for static drive, 1/2 or 1/3 bias is shown in figures 6, 7 and 8, respectively.
4. The measurement circuit for static drive, 1/2 or 1/3 bias is shown in figures 9, 10 and 11, respectively.
5. The measurement circuit for static drive, 1/2 or 1/3 bias is shown in figures 5, 3 and 4, respectively.

## Measurement Circuits

The following conditions apply to figures 3 to 5.

- Ports S and M have their hold transistors enabled.
- Bidirectional ports are in output mode and are all HIGH.
- LCD drivers are open-circuit.
- RES is open-circuit and is connected to an internal resistor.
- 32 kHz crystal oscillator frequency
- 455 kHz ceramic oscillator frequency

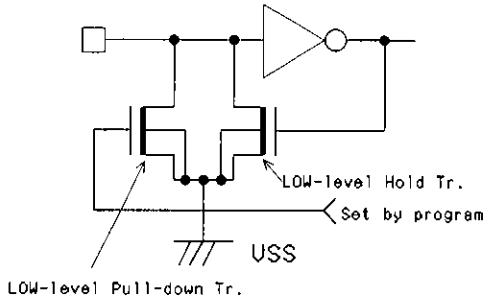

Figure 2. Input hold transistor

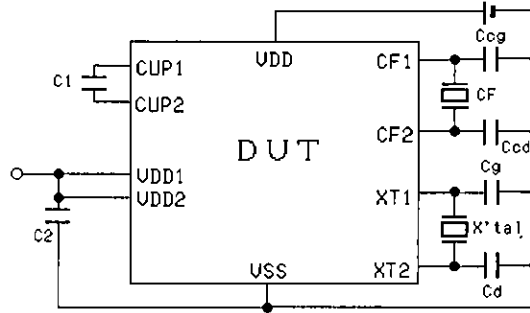

Figure 3. Oscillator characteristics 1

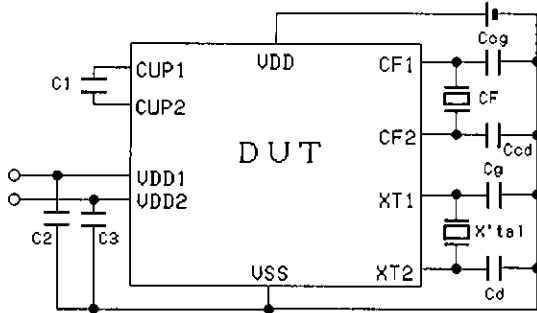

Figure 4. Oscillator characteristics 2

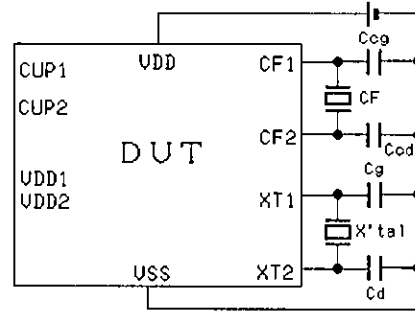
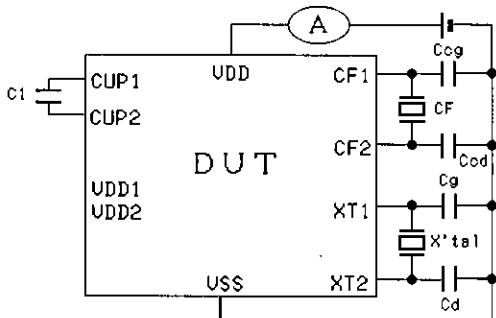
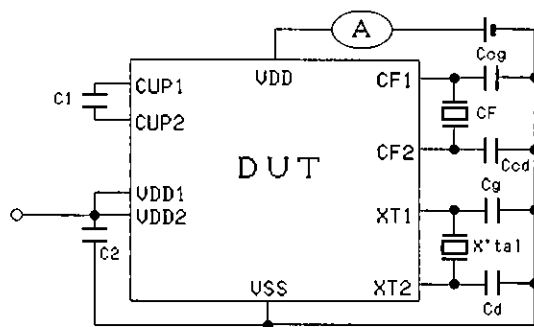

Figure 5. Oscillator characteristics 3



CR oscillator in stop mode.  
Figure 6. Supply current measurement 1



CR operate in stop mode.  
Figure 7. Supply current measurement 2

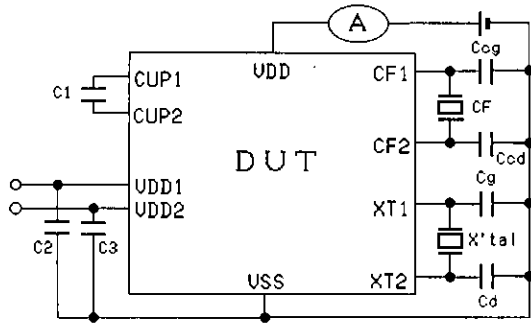

CR operate in stop mode.

Figure 8. Supply current measurement 3

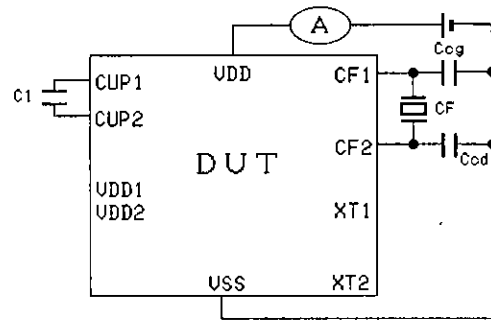

Figure 9. Supply current measurement 4

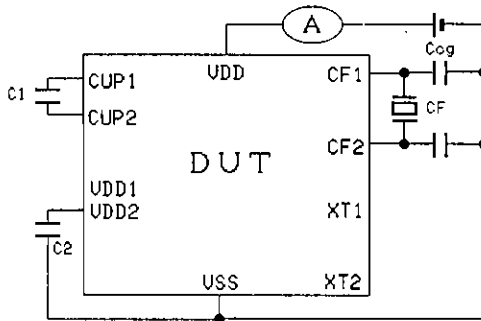

Figure 10. Supply current measurement 5

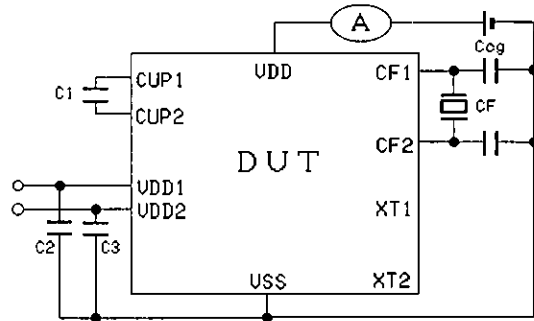

Figure 11. Supply current measurement 6

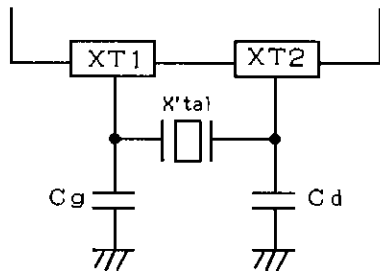

Figure 12. Crystal oscillator connections

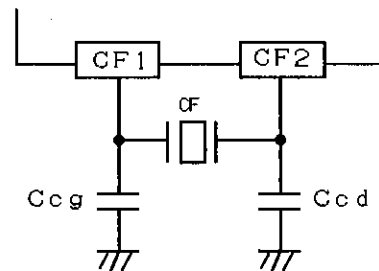

Figure 13. Ceramic oscillator connections

## Recommended Oscillators

Oscillator	Manufacturer	Part number	CG/CCG (pF)	CD/CCD (pF)
32.768 kHz crystal oscillator	Kyocera	KF-38G	18	18
		KF-38Y	16	16
	Daishinku	DT-38	15	15
455 kHz ceramic resonator	Kyocera	KBR-455BK	150	150
	Murata	CSB455E	150	150

## DEVELOPMENT TOOLS

## Manuals

- LC573400 Series User's Manual
- LC573400 Series Development Tools

## Hardware/Software

## Software development tools

- Personal computer (MS-DOS based)
- Cross assembler
  - LC573406.EXE (LC573406A)
  - LC573404.EXE (LC573404A)
- Mask option generator (SU573400.EXE)

## Hardware development tools

- LC5797 evaluation chip
- LC5797 evaluation board (TB5730)
- EVA420 evaluation board containing  
the SCR-5730 monitor ROM
- DCB-1 display and mask option control board (Rev. 3.5)
- User's application development board

## Notes

1. The RAM capacity of the LC5797 is different to that of the LC573400 series. The LC5797 has a  $256 \times 4$ -bit RAM whereas the LC573400 series has a  $128 \times 4$ -bit RAM.
2. When developing software for the LC573400 series on the LC5797 evaluation chip, use only 0H to 7H as values for DPH.

LC573400 Series Development System

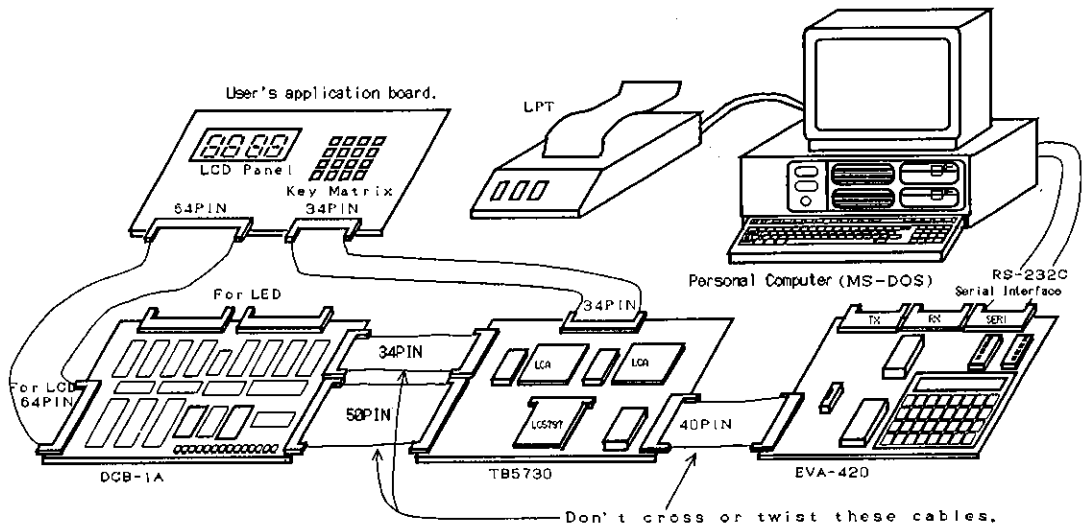

MASK OPTIONS

Combined ceramic resonator and crystal oscillator operation

The ceramic resonator and crystal oscillators can be combined in several ways as shown in figure 14.

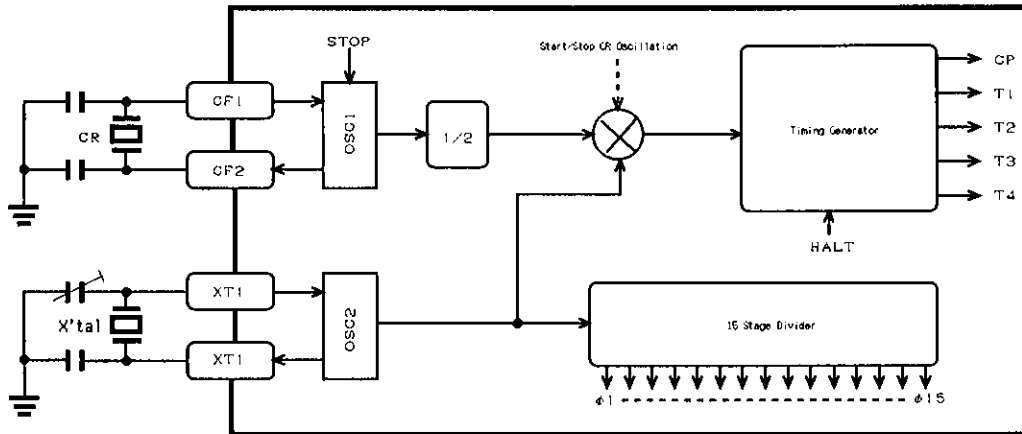

Figure 14. Oscillator configuration 1

In this configuration, the microprocessor cycle time is eight times the ceramic resonator frequency. When the ceramic resonator oscillator is stopped with the CF command, the cycle time is four times the crystal oscillator frequency. The divider outputs  $\phi 1$  to  $\phi 15$  are used to generate the LCD drive waveforms and timing pulses.

Ceramic resonator-only operation

In this configuration, the clock circuitry becomes as shown in figure 15.

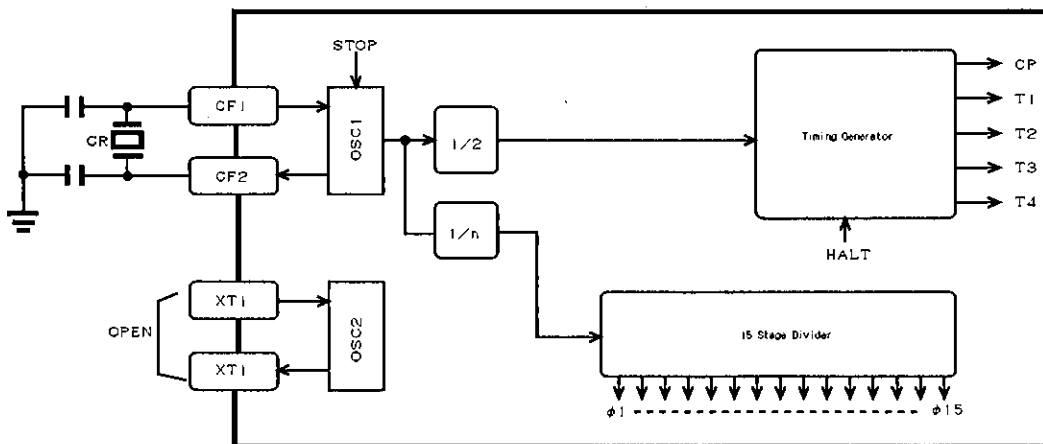

Figure 15. Oscillator configuration 2

This configuration offers the same features as the combined oscillator option with the exception that stopping the ceramic resonator oscillator also stops program execution.

Input port LOW-level latching

Ports S and M have a LOW-level input latching transistor mask option as shown in figure 16.

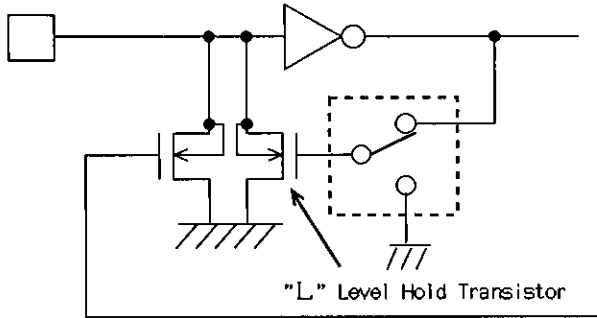

Figure 16. Input latching transistors

Remote control carrier generator

The remote control carrier generator circuitry is shown in figure 17.

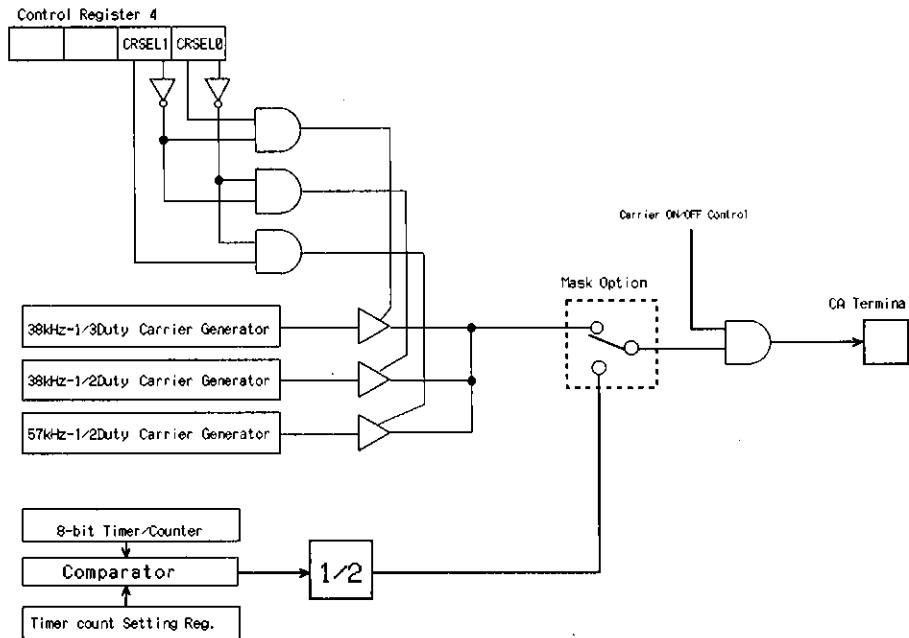

Figure 17. Carrier generator circuit

The carrier waveform can be either software selectable from one of the three fixed waveforms 38 kHz with 1/3 duty, 38 kHz with 1/2 duty and 57 kHz with 1/2 duty-or programmable using the overflow from the 8-bit timer.

LCD drive method

Any drive method can be selected from the following list.

1. Static drive
2. 1/2 bias, 1/2 duty
3. 1/2 bias, 1/3 duty
4. 1/2 bias, 1/4 duty
5. 1/3 bias, 1/3 duty
6. 1/3 bias, 1/4 duty

# LC573404A, 573406A

## OPERATING INFORMATION

### Reset

The LC573404A/LC573406A can be reset by taking  $\overline{\text{RES}}$  LOW or S1 to S4 HIGH. When the LC573404A/LC573406A is reset, the following take place.

- The pull-down resistors of ports S and M are enabled.
- CA outputs a 38 kHz,  $\frac{1}{3}$ -duty signal.
- All LCD segments and commons turn ON, and static drive is selected.
- Segment outputs configured as normal p-channel open-drain outputs go HIGH

## TYPICAL APPLICATION

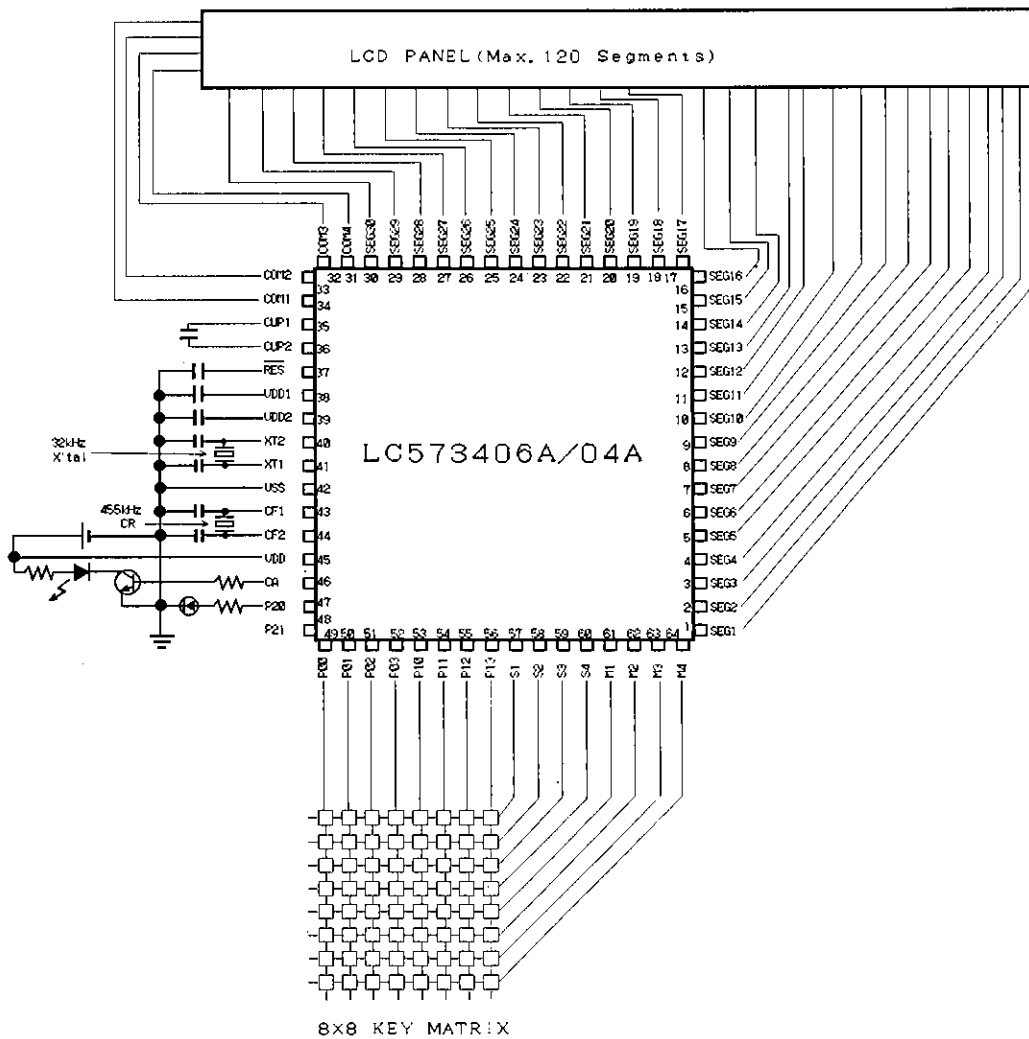



# LC573404A, 573406A

## INSTRUCTION SET

The instruction set uses the following abbreviations and symbols.

AC: Accumulator	ACn: Accumulator bit n
CF: Carry flag	DP: Data pointer
DPL: Data pointer low nibble	DPH: Data pointer high nibble
EDP: Data pointer save register	EDPL: Data pointer save register low nibble
EDPH: Data pointer save register high nibble	SP: Strobe pointer
TREG: Temporary register	SCFn: Start condition flag n
CTLn: Control register n	L(SP): LCD latch specified by SP
HEFn: HALT cancel inhibit flag n	ROM: ROM data
CFCN: Ceramic resonator oscillator control flag	M: Memory
M(DP): Memory addressed by DP	[M(DP)]: Contents of memory addressed by DP
PC: Program counter	PCn: Program counter bit n
PAGE: Page latch	STS <sub>n</sub> : Status register n
[P( )]: Contents of port n	X: Immediate data
X <sub>n</sub> : Immediate data bit n	PDF: Input port pull-down flag
SFR: Special function register	(SFR): Contents of special function register
CSTF: Chrono start flag.	SPC: Strobe pointer control bit
CCF: Carrier output control flag	( ): Contents
[ ]: Contents	( ): Complement of contents
[ ]: Complement of contents	φ <sub>n</sub> : Output from stage n of the 15-stage divider
+: Logical OR	+ : Logical exclusive-OR
·: Logical AND	←: Transfer direction or result

The special function registers are abbreviated as follows.

TCON: Timer control register	TLOW: Timer/counter register low byte
THIGH: Timer/counter register high byte	CTL4: Control register 4
P0: Port P0	P1: Port P1
P2: Port P2	

Mnemonic	Instruction code	Operation	B y t e s	C o n t r o l s	Description	Flags
Accumulator						
TAAT	0 0 0 0 0 0 0 1	AC, TREG ← ROM	1	2	Transfers the data from the memory location in the current page, pointed to by the lower 8 bits of PC, to the accumulator and to TREG.	
MTR	0 0 0 1 0 0 1 0	M(DP) ← TREG	1	1	Stores the contents of TREG in the memory location pointed to by DP.	
ASRO	0 0 0 1 1 0 0 0	AC <sub>n</sub> ← AC <sub>n+1</sub> , AC <sub>0</sub> ← 0	1	1	Shifts the contents of the accumulator right and enters 0 into the msb.	
ASR1	0 0 0 1 1 0 0 1	AC <sub>n</sub> ← AC <sub>n+1</sub> , AC <sub>0</sub> ← 1	1	1	Shifts the contents of the accumulator right and enters 1 into the msb.	
ASLO	0 0 0 1 1 0 1 0	AC <sub>n</sub> ← AC <sub>n-1</sub> , AC <sub>0</sub> ← 0	1	1	Shifts the contents of the accumulator left and enters 0 into the lsb.	
ASL1	0 0 0 1 1 0 1 1	AC <sub>n</sub> ← AC <sub>n-1</sub> , AC <sub>0</sub> ← 1	1	1	Shifts the contents of the accumulator left and enters 1 into the lsb.	
INC	1 0 0 1 1 0 0 0	AC, M(DP) ← M(DP) + 1	1	1	Increments the contents of M(DP) and stores it in the accumulator and in M(DP).	
DEC	1 0 0 1 1 0 0 1	AC, M(DP) ← M(DP) - 1	1	1	Decrements the contents of M(DP) and stores it in the accumulator and in M(DP).	
Arithmetic						
ADC	1 0 0 0 0 0 0 0	AC ← (AC) + [M(DP)] + CF	1	1	Adds the contents of the accumulator to M(DP) with carry and stores the result in the accumulator.	CF
ADC*	1 0 0 0 1 0 0 0	AC, M(DP) ← (AC) + [M(DP)] + CF	1	1	Adds the contents of the accumulator to M(DP) with carry and stores the result in the accumulator and M(DP).	CF
ADC1 X	1 0 0 1 0 0 0 0 - - - - X <sub>3</sub> X <sub>2</sub> X <sub>1</sub> X <sub>0</sub>	AC ← (AC) + X + CF	2	2	Adds the contents of the accumulator to the immediate data with carry and stores the result in the accumulator.	CF

LC573404A, 573406A

Mnemonic	Instruction code	Operation	B y t e s	C y c l e s	Description	Flags
SBC	1 0 0 0 0 0 0 1	$AC \leftarrow (AC) + [M(DP)] + CF$	1	1	Subtracts the contents of M(DP) from the accumulator with carry and stores the result in the accumulator.	CF
SBC*	1 0 0 0 1 0 0 1	$AC, M(DP) \leftarrow (AC) + [M(DP)] + CF$	1	1	Subtracts the contents of M(DP) from the accumulator with carry and stores the result in the accumulator and M(DP).	CF
SBCI X	1 0 0 1 0 0 0 1 - - - - $X_3 X_2 X_1 X_0$	$AC \leftarrow (AC) + \bar{X} + CF$	2	2	Subtracts the immediate data from the accumulator with carry and stores the result in the accumulator.	CF
ADD	1 0 0 0 0 0 1 0	$AC \leftarrow (AC) + [M(DP)]$	1	1	Adds the contents of the accumulator to the contents of M(DP) and stores the result in the accumulator.	CF
ADD*	1 0 0 0 1 0 1 0	$AC, M(DP) \leftarrow (AC) + [M(DP)]$	1	1	Adds the contents of the accumulator to the contents of M(DP) and stores the result in the accumulator and M(DP).	CF
ADDI X	1 0 0 1 0 0 1 0 - - - - $X_3 X_2 X_1 X_0$	$AC \leftarrow (AC) + X$	2	2	Adds the contents of the accumulator to the immediate data and stores the result in the accumulator.	CF
SUB	1 0 0 0 0 0 1 1	$AC \leftarrow (AC) + [M(DP)] + 1$	1	1	Subtracts the contents of M(DP) from the accumulator and stores the result in the accumulator.	CF
SBC*	1 0 0 0 1 0 1 1	$AC, M(DP) \leftarrow (AC) + [M(DP)] + 1$	1	1	Subtracts the contents of M(DP) from the accumulator and stores the result in the accumulator and M(DP).	CF
SBCI X	1 0 0 1 0 0 1 1 - - - - $X_3 X_2 X_1 X_0$	$AC \leftarrow (AC) + \bar{X} + 1$	2	2	Subtracts the immediate data from the accumulator and stores the result in the accumulator.	CF
ADN	1 0 0 0 0 1 0 0	$AC \leftarrow (AC) + [M(DP)]$	1	1	Adds the contents of the accumulator to the contents of M(DP) and stores the result in the accumulator.	
ADN*	1 0 0 0 1 1 0 0	$AC, M(DP) \leftarrow (AC) + [M(DP)]$	1	1	Adds the contents of the accumulator to the contents of M(DP) and stores the result in the accumulator and M(DP).	
ADNI X	1 0 0 1 0 1 0 0 - - - - $X_3 X_2 X_1 X_0$	$AC \leftarrow (AC) + X$	2	2	Adds the contents of the accumulator to the immediate data and stores the result in the accumulator.	
Logical						
AND	1 0 0 0 0 1 0 1	$AC \leftarrow (AC) \wedge [M(DP)]$	1	1	Takes the logical AND of the contents of the accumulator and the contents of M(DP) and stores the result in the accumulator.	
AND*	1 0 0 0 1 1 0 1	$AC, M(DP) \leftarrow (AC) \wedge [M(DP)]$	1	1	Takes the logical AND of the contents of the accumulator and the contents of M(DP) and stores the result in the accumulator and in M(DP).	
ANDI X	1 0 0 1 0 1 0 1 - - - - $X_3 X_2 X_1 X_0$	$AC \leftarrow (AC) \wedge X$	2	2	Takes the logical AND of the contents of the accumulator and the immediate data and stores the result in the accumulator.	
EOR	1 0 0 0 0 1 1 0	$AC \leftarrow (AC) \vee [M(DP)]$	1	1	Takes the logical exclusive-OR of the contents of the accumulator and the contents of M(DP) and stores the result in the accumulator.	
EOR*	1 0 0 0 1 1 1 0	$AC, M(DP) \leftarrow (AC) \vee [M(DP)]$	1	1	Takes the logical exclusive-OR of the contents of the accumulator and the contents of M(DP) and stores the result in the accumulator and in M(DP).	
EORI X	1 0 0 1 0 1 1 0 - - - - $X_3 X_2 X_1 X_0$	$AC \leftarrow (AC) \vee X$	2	2	Takes the logical exclusive-OR of the contents of the accumulator and the immediate data and stores the result in the accumulator.	
OR	1 0 0 0 0 1 1 1	$AC \leftarrow (AC) \vee [M(DP)]$	1	1	Takes the logical OR of the contents of M(DP) and the accumulator and stores the result in the accumulator.	
OR*	1 0 0 0 1 1 1 1	$AC, M(DP) \leftarrow (AC) \vee [M(DP)]$	1	1	Takes the logical OR of the contents of M(DP) and the accumulator and stores the result in the accumulator and in M(DP).	
ORI X	1 0 0 1 0 1 1 1 - - - - $X_3 X_2 X_1 X_0$	$AC \leftarrow (AC) \vee X$	2	2	Takes the logical OR of the contents of the accumulator and the immediate data and stores the result in the accumulator.	

LC573404A, 573406A

Mnemonic	Instruction code	Operation	B y t e s	C y c l e s	Description	Flags
Data pointer						
SDPL	0 0 0 1 1 1 0 0	DPL ← (AC)	1	1	Stores the contents of the accumulator in DPL.	
SDPH	0 0 0 1 1 1 0 1	DPH ← (AC)	1	1	Stores the contents of the accumulator in DPH.	
LDPL	1 1 1 1 1 1 0 1	AC ← (DPL)	1	1	Loads the contents of DPL into the accumulator.	
LDPH	1 1 1 1 1 1 1 0	AC ← (DPH)	1	1	Loads the contents of DPH into the accumulator.	
MDPL X	1 0 1 1 X <sub>3</sub> X <sub>2</sub> X <sub>1</sub> X <sub>0</sub>	DPL ← X	1	1	Stores the immediate data in DPL.	
MDPH X	1 1 0 0 X <sub>3</sub> X <sub>2</sub> X <sub>1</sub> X <sub>0</sub>	DPH ← X	1	1	Stores the immediate data in DPH.	
EDPL	0 0 0 1 1 1 1 0	(DPL) ↔ (EDPL)	1	1	Swaps the contents of DPL and EDPL.	
EDPH	0 0 0 1 1 1 1 1	(DPH) ↔ (EDPH)	1	1	Swaps the contents of DPH and EDPH.	
IDPL	1 0 0 1 1 0 1 0	DPL ← (DPL) + 1	1	1	Increments the contents of DPL and stores the result in DPL.	
IDPH	1 0 0 1 1 1 0 0	DPH ← (DPH) + 1	1	1	Increments the contents of DPH and stores the result in DPH.	
DDPL	1 0 0 1 1 0 1 1	DPL ← (DPL) - 1	1	1	Decrements the contents of DPL and stores the result in DPL.	
DDPH	1 0 0 1 1 1 0 1	DPH ← (DPH) - 1	1	1	Decrements the contents of DPH and stores the result in DPH.	
SSP	1 0 1 0 1 1 1 0	SP ← (AC)	1	1	Stores the contents of the accumulator in SP.	
LSP	1 0 1 0 1 0 1 0	AC ← (SP)	1	1	Loads the contents of SP into the accumulator.	
MSP X	1 1 1 0 X <sub>3</sub> X <sub>2</sub> X <sub>1</sub> X <sub>0</sub>	SP ← X	1	1	Stores the immediate data in SP.	
ISP	1 0 0 1 1 1 1 0	SP ← (SP) + 1	1	1	Increments the contents of SP and stores the result in SP.	
DSP	1 0 0 1 1 1 1 1	SP ← (SP) - 1	1	1	Decrements the contents of SP and stores the result in SP.	
Flag						
LHLT	1 0 1 0 1 0 1 1	AC ← (STS2), STS2 ← 0	1	1	Loads the contents of STS2 into the accumulator and clears STS2.	SCF1~4
L500	1 0 1 0 1 1 0 0	AC ← (STS1), SCF0 ← 0	1	1	Loads the contents of STS1 into the accumulator and clears SCF0.	SCF0
CSP	0 0 0 0 0 1 0 0	CSTF ← 0	1	1	Clears CSTF.	CSTF
CST	0 0 0 0 0 1 0 1	CSTF ← 1	1	1	Sets CSTF.	CSTF
RC5	0 0 0 0 0 1 1 0	HEF0 ← 0	1	1	Clears HEF0 to prevent HALT-mode cancellation when the divider overflows.	HEF0
SC5	0 0 0 0 0 1 1 1	HEF0 ← 1	1	1	Sets HEF0 to enable HALT-mode cancellation when the divider overflows.	HEF0
RCF	1 1 1 1 0 0 0 0	CF ← 0	1	1	Clears CF.	CF
SCF	1 1 1 1 0 0 0 1	CF ← 1	1	1	Sets CF.	CF
Data transfer						
LDA	1 0 1 0 1 0 0 1	AC ← [M(DP)]	1	1	Loads the contents of M(DP) into the accumulator.	
STA	1 0 1 0 1 1 0 0	M(DP) ← (AC)	1	1	Stores the contents of the accumulator in M(DP).	CF
LDI X	0 0 1 1 X <sub>3</sub> X <sub>2</sub> X <sub>1</sub> X <sub>0</sub>	AC ← X	1	1	Loads the immediate data into the accumulator.	
MVI X	0 0 1 0 X <sub>3</sub> X <sub>2</sub> X <sub>1</sub> X <sub>0</sub>	M(DP) ← X	1	1	Loads the immediate data into M(DP).	

LC573404A, 573406A

Mnemonic	Instruction code	Operation	Bytes	Cycles	Description	Flag
CPU control						
HALT	0 0 0 0 0 0 0 0	CPU halted	1	1	Stops the CPU. HALT mode is cancelled by the interaction of the SIC X and SC5 commands.	
					Stores the immediate data in CTL2. The lower 4 bits of the instruction code control the HALT mode cancellation. The functions of these bits, X0 to X3, are described below.	
					X <sub>0</sub> This bit sets HEF1, cancelling HALT mode with the divider overflow signal.	
					X <sub>1</sub> This bit sets HEF2, cancelling HALT mode with a rising edge on port S.	
					X <sub>2</sub> This bit sets HEF3, cancelling HALT mode with a rising edge on port M.	
X <sub>3</sub> This bit sets HEF4, cancelling HALT mode with the 10 Hz timing pulse.						
NOP	1 1 1 1 1 1 1 1	NO OPERATION.	1	1	No Operation.	
Input/output						
IPS	1 0 1 0 1 1 1 1	AC ← [P(S)]	1	1	Loads the input data on port S into the accumulator.	
IPM	1 0 1 0 1 0 0 0	AC ← [P(M)]	1	1	Loads the input data on port M into the accumulator.	
SPDR X	1 1 1 1 0 1 X <sub>1</sub> X <sub>0</sub>	PDF ← X	1	1	Stores the immediate data in PDF. PDF controls the internal pull-down resistors on ports S and M. The functions of bits X0 and X1 are described below.	PDF
					X0 The pull-down resistors on port S are enabled when X0 is set and disabled when X0 is cleared.	
					X1 The pull-down resistors on port M are enabled when X1 is set and disabled when X0 is cleared.	
OUT	1 1 1 1 1 1 0 0	When SPC = 0 and SP = 0H to CH, EH or FH, L(SP) ← (AC) and [M(DP)]	1	1	Transfers the contents of M(DP) and the accumulator to the LCD driver specified by SP.	
		When SPC = 0 and SP = DH, CTL3 ← (AC)			Stores the contents of the accumulator in CTL3.	CFCF CCF
		When SPC = 1, SFR ← (AC)			Stores the contents of the accumulator in SFR.	
TWRT	0 0 0 0 0 0 1 0	When SPC = 0 and SP = 0H to CH, EH or FH, L(SP) ← ROM	1	2	Transfers the lower eight bits of PC in the current page to the accumulator, and the ROM data, pointed to by the accumulator and M(DP), to the LCD driver specified by SP.	
		When SPC = 0 and SP = DH, CTL3 ← (AC)			Transfers the lower eight bits of PC in the current page to the accumulator, and the upper eight bits of the ROM data, pointed to by the accumulator and M(DP), to CTL3.	CFCF CCF
		When SPC = 1, SFR ← (AC)			Transfers the lower eight bits of PC in the current page to the accumulator, and the upper four or eight bits of the ROM data, pointed to by the accumulator and M(DP), to SFR.	
IN	0 0 0 1 0 1 1 1	When SPC = 0 and SP = 0H to CH, EH or FH, this instruction is invalid.	1	1	The execution of the IN comand when SPC = 1 and SP = 0H to CH, EH or FH will result in the device malfunctioning and so should not be used.	
		When SPC = 0, and SP = DH, AC ← (STS3)			Loads the contents of STS3 into the accumulator.	
		When SPC = 1, AC ← (SFR)			Loads the contents of SFR into the accumulator.	
Branching/subroutine						

LC573404A, 573406A

Mnemonic	Instruction code	Operation	B y t e s	C y c l e s	Description	Flags
JMP X	0 0 0 0 1X <sub>10</sub> X <sub>9</sub> X <sub>8</sub> X <sub>7</sub> X <sub>6</sub> X <sub>5</sub> X <sub>4</sub> X <sub>3</sub> X <sub>2</sub> X <sub>1</sub> X <sub>0</sub>	(PC <sub>10</sub> ~PC <sub>0</sub> )←X <sub>10</sub> ~X <sub>0</sub>	2	2	Transfers the data specified by X0 to X10 to the program counter and makes an unconditional jump.	
BAB0 X	0 1 0 0 1X <sub>10</sub> X <sub>9</sub> X <sub>8</sub> X <sub>7</sub> X <sub>6</sub> X <sub>5</sub> X <sub>4</sub> X <sub>3</sub> X <sub>2</sub> X <sub>1</sub> X <sub>0</sub>	if AC <sub>0</sub> =1 THEN (PC <sub>10</sub> ~PC <sub>0</sub> )←X <sub>10</sub> ~X <sub>0</sub>	2	2	If bit 0 of the accumulator is set, transfers the data specified by X0 to X10 to the program counter and jumps to that address. If the bit is not set, the program counter is incremented.	
BAB1 X	0 1 0 1 1X <sub>10</sub> X <sub>9</sub> X <sub>8</sub> X <sub>7</sub> X <sub>6</sub> X <sub>5</sub> X <sub>4</sub> X <sub>3</sub> X <sub>2</sub> X <sub>1</sub> X <sub>0</sub>	if AC <sub>1</sub> =1 THEN (PC <sub>10</sub> ~PC <sub>0</sub> )←X <sub>10</sub> ~X <sub>0</sub>	2	2	If bit 1 of the accumulator is set, transfers the data specified by X0 to X10 to the program counter and jumps to that address. If the bit is not set, the program counter is incremented.	
BAB2 X	0 1 1 0 1X <sub>10</sub> X <sub>9</sub> X <sub>8</sub> X <sub>7</sub> X <sub>6</sub> X <sub>5</sub> X <sub>4</sub> X <sub>3</sub> X <sub>2</sub> X <sub>1</sub> X <sub>0</sub>	if AC <sub>2</sub> =1 THEN (PC <sub>10</sub> ~PC <sub>0</sub> )←X <sub>10</sub> ~X <sub>0</sub>	2	2	If bit 2 of the accumulator is set, transfers the data specified by X0 to X10 to the program counter and jumps to that address. If the bit is not set, the program counter is incremented.	
BAB3 X	0 1 1 1 1X <sub>10</sub> X <sub>9</sub> X <sub>8</sub> X <sub>7</sub> X <sub>6</sub> X <sub>5</sub> X <sub>4</sub> X <sub>3</sub> X <sub>2</sub> X <sub>1</sub> X <sub>0</sub>	if AC <sub>3</sub> =1 THEN (PC <sub>10</sub> ~PC <sub>0</sub> )←X <sub>10</sub> ~X <sub>0</sub>	2	2	If bit 3 of the accumulator is set, transfers the data specified by X0 to X10 to the program counter and jumps to that address. If the bit is not set, the program counter is incremented.	
BAZ X	0 1 0 0 0X <sub>10</sub> X <sub>9</sub> X <sub>8</sub> X <sub>7</sub> X <sub>6</sub> X <sub>5</sub> X <sub>4</sub> X <sub>3</sub> X <sub>2</sub> X <sub>1</sub> X <sub>0</sub>	if AC=0 THEN (PC <sub>10</sub> ~PC <sub>0</sub> )←X <sub>10</sub> ~X <sub>0</sub>	2	2	If the accumulator is zero, transfers the data specified by X0 to X10 to the program counter and jumps to that address. If the accumulator is not zero, the program counter is incremented.	
BANZ X	0 1 0 1 0X <sub>10</sub> X <sub>9</sub> X <sub>8</sub> X <sub>7</sub> X <sub>6</sub> X <sub>5</sub> X <sub>4</sub> X <sub>3</sub> X <sub>2</sub> X <sub>1</sub> X <sub>0</sub>	if AC≠0 THEN (PC <sub>10</sub> ~PC <sub>0</sub> )←X <sub>10</sub> ~X <sub>0</sub>	2	2	If the accumulator is not zero, transfers the data specified by X0 to X10 to the program counter and jumps to that address. If the accumulator is zero, the program counter is incremented.	
BCNH X	0 1 1 0 0X <sub>10</sub> X <sub>9</sub> X <sub>8</sub> X <sub>7</sub> X <sub>6</sub> X <sub>5</sub> X <sub>4</sub> X <sub>3</sub> X <sub>2</sub> X <sub>1</sub> X <sub>0</sub>	if CF≠1 THEN (PC <sub>10</sub> ~PC <sub>0</sub> )←X <sub>10</sub> ~X <sub>0</sub>	2	2	If CF is cleared, transfers the data specified by X0 to X10 to the program counter and jumps made to that address. If CF is set, the program counter is incremented.	
BCH X	0 1 1 1 0X <sub>10</sub> X <sub>9</sub> X <sub>8</sub> X <sub>7</sub> X <sub>6</sub> X <sub>5</sub> X <sub>4</sub> X <sub>3</sub> X <sub>2</sub> X <sub>1</sub> X <sub>0</sub>	if CF=1 THEN (PC <sub>10</sub> ~PC <sub>0</sub> )←X <sub>10</sub> ~X <sub>0</sub>	2	2	If CF is set, transfers the data specified by X0 to X10 to the program counter and jumps to that address. If CF is cleared, the program counter is incremented.	
PAGE	0 0 0 1 0 0 0 1	PAGE←[M(DP)]	1	1	Transfers the contents of M(DP) to the data page latch.	
JMP*	0 0 0 1 0 0 0 0	PC <sub>10</sub> ~PC <sub>8</sub> ←(PAGE) PC <sub>7</sub> ~PC <sub>4</sub> ←(AC) PC <sub>3</sub> ~PC <sub>0</sub> ←[M(DP)]	1	1	Transfers the data from the accumulator, page latch and the contents of M(DP) to the program counter and jumps to that address.	
ROM0	1 1 0 0 1 0 0 0 0 0 1 0 0 0 0 0	PC <sub>12</sub> ~PC <sub>11</sub> ←0	2	2	Selects ROM bank 0.	
ROM1	1 1 0 0 1 0 0 0 0 0 1 0 0 0 0 1	PC <sub>12</sub> ~PC <sub>11</sub> ←1	2	2	Selects ROM bank 1.	
ROM2	1 1 0 0 1 0 0 0 0 0 1 0 0 0 1 0	PC <sub>12</sub> ~PC <sub>11</sub> ←2	2	2	Selects ROM bank 2.	
JSR X	0 0 0 0 1X <sub>10</sub> X <sub>9</sub> X <sub>8</sub> X <sub>7</sub> X <sub>6</sub> X <sub>5</sub> X <sub>4</sub> X <sub>3</sub> X <sub>2</sub> X <sub>1</sub> X <sub>0</sub>	STACK←(PC)+2 (PC <sub>10</sub> ~PC <sub>0</sub> )←X <sub>10</sub> ~X <sub>0</sub>	2	2	Pushes PC + 2 onto the stack, transfers the data specified by X0 to X10 to the program counter and calls the subroutine at that address.	
RTS	0 0 0 1 0 0 1 1	PC←(STACK)	1	1	Recovers the program counter from the stack and returns from the subroutine.	
Miscellaneous						
SPC0	1 1 0 0 1 0 0 1 0 0 1 0 0 0 0 0	SPC←0	2	2	Clears the SPC flag.	SPC
SPC1	1 1 0 0 1 0 0 1 0 0 1 0 0 0 0 1	SPC←1	2	2	Sets the SPC flag.	SPC
CSEC	1 1 1 1 1 0 1 1	φ11~φ15←0	1	1	Clears the upper four bits of the programmable divider and flags SCF0 and SCF4.	SCF0 SCF4

# LC573404A, 573406A

## Instruction Set Summary

Lower Upper	0	1	2	3	4	5	6	7	8	9	A	B	C	D	E	F
0	HALT	TAAT	TWRT	-	CSP	CST	RC5	SC5	JMP X							
1	JMP*	PAGE	MTR	RTS	-	-	-	IN	ASRO	ASRI	ASLO	ASLI	SDPL	SDPH	EDPL	EDPH
2	MVI X															
3	LDI X															
4	BAZ X								BAB0 X							
5	BANZ X								BAB1 X							
6	BCNH X								BAB2 X							
7	BCH X								BAB3 X							
8	ADC	SBC	ADD	SUB	ADN	AND	EOR	OR	ADC*	SBC*	ADD*	SUB*	ADN*	AND*	EOR*	OR*
9	ADCI	SBCI	ADDI	SUBI	ADNI	ANDI	EORI	ORI	INC	DEC	IDPL	DDPL	IDPH	DDPH	ISP	DSP
A	JSR X								IPM	LDA	LSP	LHLT	L500	STA	SSP	IPS
B	MDPL X															
C	MDPH X								ROMX	SPCX						
D	SIC X															
E	MSP X															
F	RCF	SCF	NOP	NOP	SPDR X				-	-	-	CSEC	OUT	LDPL	LDPH	NOP

XXX :1 Byte, 1 Cycle command

ROMX is the first byte of the ROM0 (C820H), ROM1 (C821H) and ROM2 (C822H) commands.

XXX :2 Byte, 2 Cycle command

SPCX is the first byte of the SPC0 (C920H) and SPC1 (C921H) commands.

XXX :1 Byte, 2 Cycle command