



LA7583

IF Signal Processing Circuit (A²C PLL VIF + SIF) for TVs and VCRs

Overview

The LA7583 is a VIF + SIF IC that requires no adjustments. In order to eliminate the need for adjustments in the VIF block, a multi-network PLL has been developed and adopted for video detection. In the SIF block, adjustments were eliminated by using gyrator technology in the FM quadrature detector. In addition to eliminating the need for adjustments, a buzz canceller that suppresses Nyquist buzz has been built into the LA7583 in order to provide excellent sound quality.

Features

- Elimination of VCO, AFT, and SIF coils eliminates the need for adjustments.
- A variety of built-in filters.
- Built-in buzz canceller results in excellent audio characteristics.

Note: A²C Automatic Adjustment Control
AQT Automatic Quadrature Tuning

Functions

[VIF]

- VIF amplifier
- Equalizer amplifier
- AGC lag lead filter

[1st SIF]

- Preamplifier

[SIF]

- Limiter amplifier

[mute]

- Audio mute

- Multinetwork PLL
- AFT
- Video driver

- 1st SIF detector

- AQT detector (gyrator)

- AV mute

Package Dimensions

unit : mm

3067-DIP24S

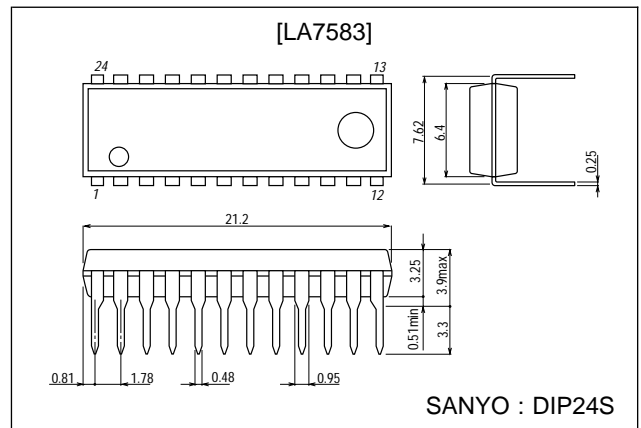

■ Any and all SANYO products described or contained herein do not have specifications that can handle applications that require extremely high levels of reliability, such as life-support systems, aircraft's control systems, or other applications whose failure can be reasonably expected to result in serious physical and/or material damage. Consult with your SANYO representative nearest you before using any SANYO products described or contained herein in such applications.

■ SANYO assumes no responsibility for equipment failures that result from using products at values that exceed, even momentarily, rated values (such as maximum ratings, operating condition ranges, or other parameters) listed in products specifications of any and all SANYO products described or contained herein.

LA7583

Specifications

Maximum Ratings at Ta = 25 °C

Parameter	Symbol	Conditions	Ratings	Unit
Maximum supply voltage	V _{CC 1}		7	V
	V _{CC 2}		13.2	V
Circuit voltage	V4		V _{CC 1}	V
	V3, V11		V _{CC 2}	V
Circuit current	I1, I10, I23		-1	mA
	I3, I21		-3	mA
	I15, I19		-5	mA
Allowable power dissipation	Pd max	T _a ≤ 50 °C	1000	mW
Operating temperature	T _{opr}		-20 to +70	°C
Storage temperature	T _{stg}		-55 to +150	°C

* A²C (Automatic Adjustment Control)

Note: Current flowing into the IC is positive (no signal) and current flowing out is negative.

Pin Assignment

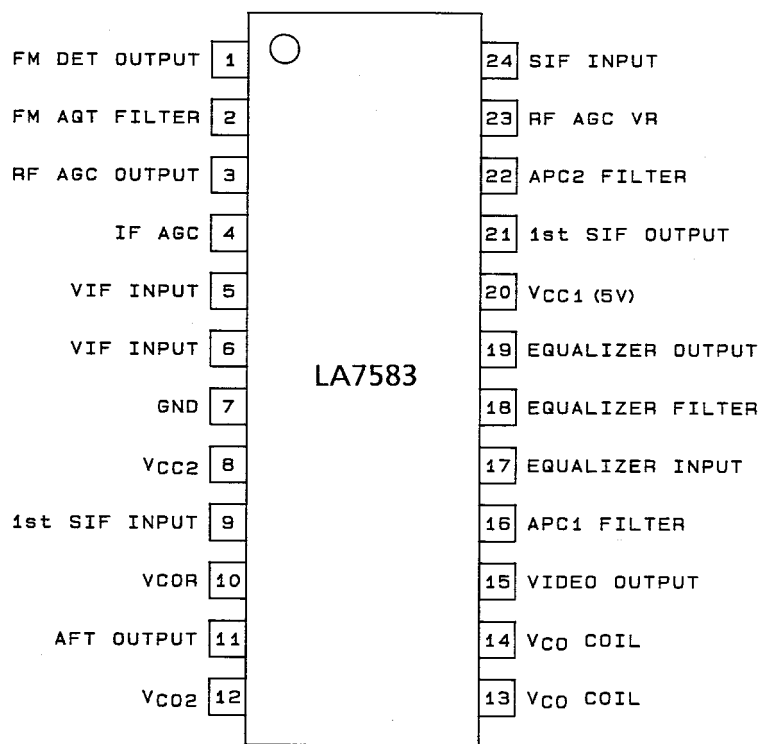

Top View

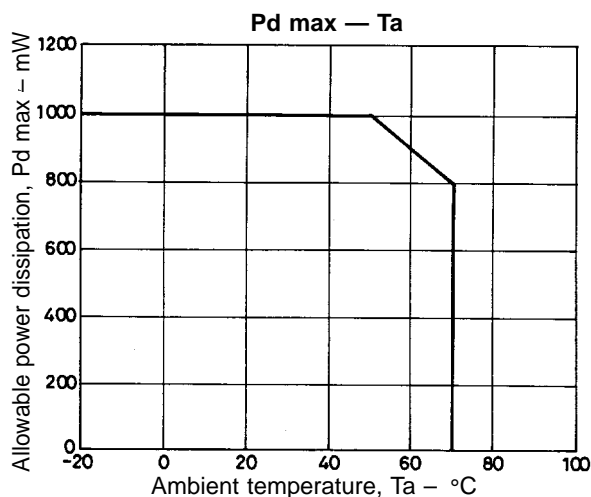

LA7583

Operating Conditions at Ta = 25 °C

Parameter	Symbol	Conditions	Ratings	Unit
Recommended supply voltage	V _{CC1}		5	V
	V _{CC2}		9	V
Operating supply voltage range	V _{CC1}		4.6 to 6	V
	V _{CC2}		7 to 12	V

Electrical Characteristics at Ta = 25 °C, V_{CC1} = 5 V, V_{CC2} = 9 V, f_p = 45.75 MHz

Parameter	Symbol	Conditions	min	typ	max	Unit
[VIF Block]						
Circuit current 1	I ₂₀	V _{CC} = 5 V	57	66	78	mA
Circuit current 2	I ₈	V _{CC} = 9 V	7.8	11.0	14.0	mA
Maximum RF AGC voltage	V _{3H}	V ₄ = 3 V	7.5	8.1	9	V
Minimum RF AGC voltage	V _{3L}	V ₄ = 1.5 V		0	+0.5	V
Input sensitivity	V _i	S ₁ = OFF	32	38	44	dBμ
AGC range	G _R		56	62		dB
Maximum Allowable Input	V _i max		95	103		dBμ
Video output voltage with no signal	V ₁₉	V ₄ = 2 V	3.3	3.6	3.9	V
Sync signal tip voltage	V ₁₉ (tip)	V _i = 10 mV	1.1	1.4	1.7	V
Video output amplitude	V _O (V)	87.5% mod	1.7	2.0	2.3	Vp-p
Black noise threshold level voltage	V _{BTH}		0.4	0.7	1.1	V
Black noise clamp voltage	V _{BCL}		1.65	1.95	2.25	V
Output S/N	S/N		48	52		dB
920 kHz beat level	I ₉₂₀	P = 0, C = -10 dB, S = -10 dB	41	45		dB
Frequency characteristics	f _C	P = 0, S = -14 dB	6	8		MHz
Differential gain	DG	V _i = 10 mV, 87.5%		3	8	%
Differential phase	DP	10STAR STEP		3	8	rad
AFT output voltage with no signal	V ₁₁		0.3	4.5	8.7	V
Maximum AFT output voltage	V _{11H}		7.5	8.5	9	V
Minimum AFT output voltage	V _{11L}		0	+1	+1.5	V
AFT detection sensitivity	S _f		33	48	69	mV/kHz
VIF input resistance	R _i (VIF)	f = 45.75 MHz	0.8	1.1	1.5	kΩ
VIF input capacity	C _i (VIF)	f = 45.75 MHz	2	3	5	pF
APC pull-in range (U)	f _{PU}		1.0	3		MHz
APC pull-in range (L)	f _{PL}			-4.5	-1.0	MHz
AFT crossover frequency	Δf _A		-65		+65	kHz
VCO1 maximum variable range	Δf _{U1}	V ₂₂ = 4 V	2.0	5.0		MHz
	Δf _{L1}	V ₂₂ = 2 V		-5.0	-2.0	MHz
VCO2 maximum variable range	Δf _{U2}	V ₁₆ = 4 V	100	200		kHz
	Δf _{L2}	V ₁₆ = 2 V		-1000	-200	kHz
VCO1 control sensitivity	β ₁	V ₂₂ = 2.8 V to 3.2 V	2.4	4.8	9.6	kHz/mV
VCO2 control sensitivity	β ₂	V ₁₆ = 2.8 V to 3.2 V	0.3	0.6	1.2	kHz/mV
[1st SIF Block]						
4.5 MHz output gain	V _G	V _i = 1 mV, 41.25 MHz	23	26	29	dB
4.5 MHz output level	S _O	V _i = 10 mV, 41.25 MHz	50	85	120	mVrms
1st SIF maximum input level	S _i (max)	S _o + 12 dB - 1 dB	60	70		mVrms
1st SIF input resistance	R _i (SIF1)	f = 41.25 MHz	1.2	2		kΩ
1st SIF input capacity	C _i (SIF1)	f = 41.25 MHz		3	6	pF

Continued next page.

LA7583

Continued from preceding page.

Parameter	Symbol	Conditions	min	typ	max	Unit
[SIF Block]						
SIF limiting sensitivity	V_i (lim)	$\Delta f = 25 \text{ kHz}, 400 \text{ Hz}$	47	53	59	$\text{dB}\mu$
FM detection output voltage	V_O	$V_i = 100 \text{ mV}, \Delta f = 25 \text{ kHz}, 400 \text{ Hz}$	300	400	520	mVrms
AMR	AMR	$\text{AM} = 30\%, 400 \text{ Hz}$	40	56		dB
Total harmonic distortion	THD	$\Delta f = 25 \text{ kHz}, 400 \text{ Hz}$		0.4	1.5	%
SIF S/N	S/N(SIF)	$\Delta f = 25 \text{ kHz}, 400 \text{ Hz}$	55	59		dB
[Mute defeat]						
FM mute	V24T		0.5	1.0		V
AFT defeat voltage	VD11		3.9	4.5	5.1	V
J/U SW start voltage	VJU24		1.5	2.0	2.5	V
AV mute voltage	VM23		1	1.5		V

Equivalent Circuit Block Diagram

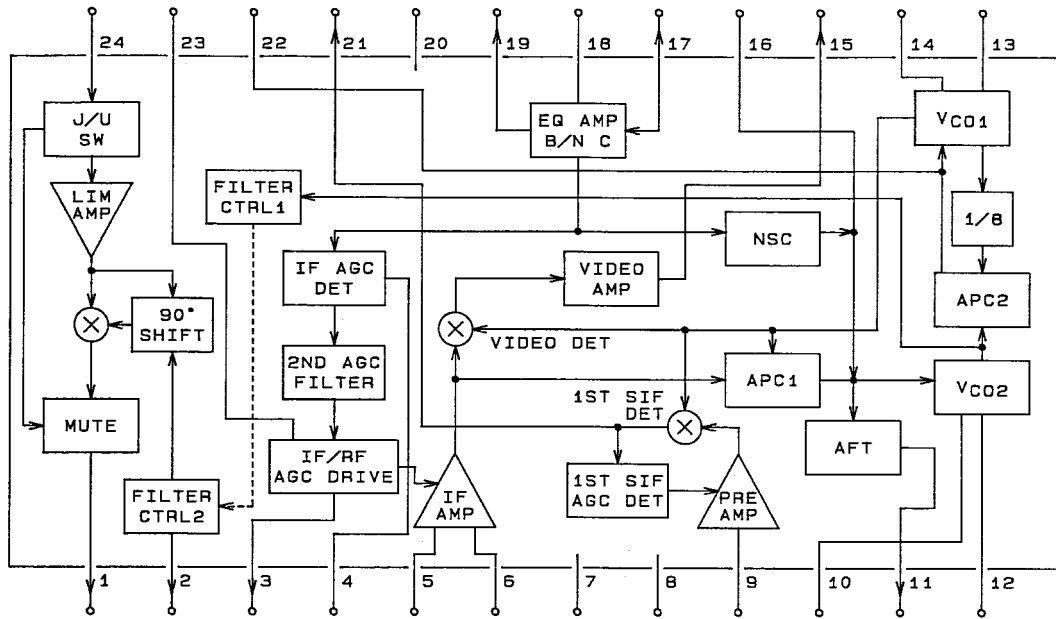

A04197

Multinetwork PLL (Automatic Adjustment Control)

The LA7583's PIF detector uses a multinetwork PLL and a buzz canceller. The multinetwork PLL is a PLL detector that was developed in order to eliminate the need for adjustments in video detection.

This PLL detector offers the following features:

- (1) Eliminates the need for adjustments in video detection.
- (2) The PLL detection characteristics are unaltered.
 - a. Offers better waveform response characteristics in comparison with the quasi-synchronous detection method.
 - b. The harmonic wave component of the video signal (demodulated output) is reduced.
 - c. The 1/2 IF signal suppression ratio is improved.
- (3) Audio buzz is greatly reduced by the buzz canceller.

A typical PLL detector consists of the blocks shown below.

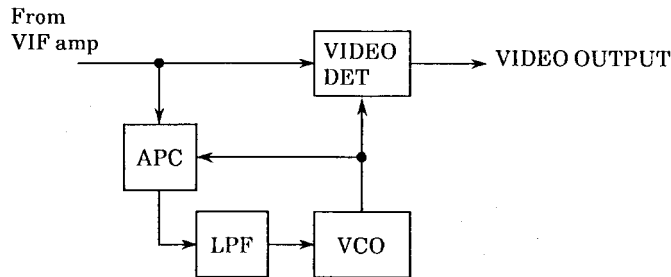

(PLL DETECTOR)

In these blocks, if the VCO coil is not adjusted to the IF frequency, a phase difference will appear in the control loop. As a result, the PLL detector detection axis will shift from the ideal 180°. The group delay, DP characteristics, etc., deteriorate as a result.

[Multinetwork PLL]

The multinetwork PLL consists of the blocks shown below.

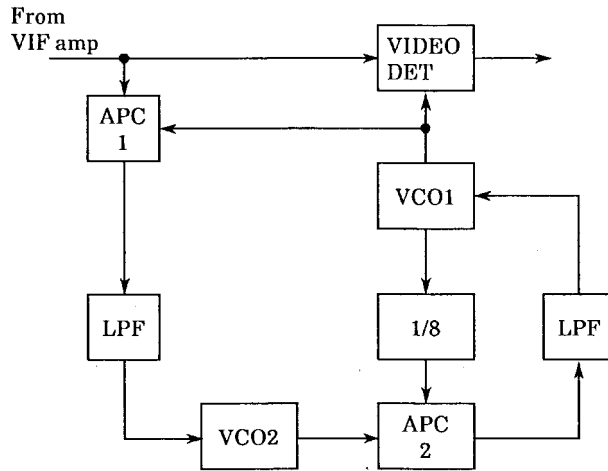

(MULTI NETWORK PLL)

The multinetwork PLL has two VCO circuits. Each of these form a separate PLL. The operational relationship between these circuits is as follows:

$$f_{VCO1} = f_{VCO2} \times 8$$

Initially, in APC1, the phases of the IF signal and the VCO carrier are compared. The control signal derived is then used to control VCO2. VCO1 is controlled by comparing the phases of VCO2 and VCO1 x 1/8. As a result, VCO1 always has the same frequency as the IF signal, and the following relationship results:

$$f_{VCO1} = f_{VCO2} \times 8$$

If the precision of the ceramic oscillator for f_{VCO2} is within the adjustment range for VCO in a typical PLL, the video detector phase error is very small. As a result, the multinetwork PLL operates as an ideal PLL detector.

Automatic Quadrature Tuning (AQT)

A quadrature detector that is controlled automatically is used in the FM detector. The AQT in the LA7583 consists of the blocks shown in the following diagram.

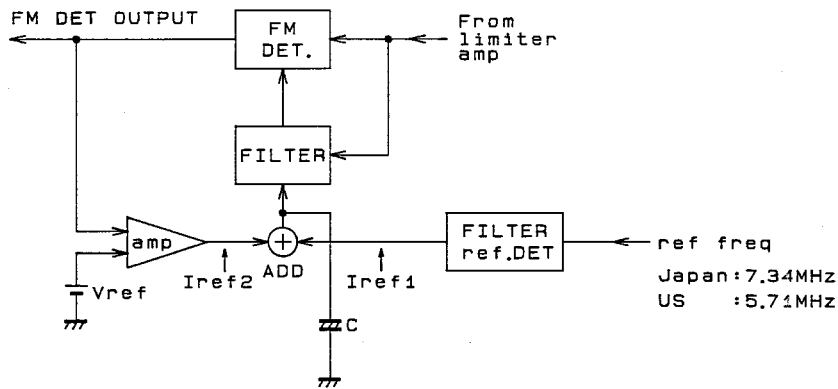

(Auto matic Quad Tuning)

A04198

The FM detection filter (gyrator) is controlled at 4.5 MHz by the control current (Iref1) generated by reference circuit 1. At the same time, precision control is performed by using the control current (Iref2) derived by detecting the offset from the detected output so that the FM detector phase relationship is 90°. As a result, automatic control makes an ideal quadrature detector possible.

(Note) Gyrator: Circuit-formed equivalent inductance

The SIF circuit contains a 4.5 MHz tank circuit having the gyrator and an internal capacitor.

Pin Functions

Pin No.	Symbol	Circuit Configuration	Description
1	FM DETECTOR OUTPUT	<p style="text-align: right;">A04190</p>	<p>Pin 1 is an audio FM output pin. A 100 Ω resistor is connected in series with the emitter follower.</p> <p>(1) Monaural applications CR are used to form a de-emphasis circuit externally. $t = CR1$</p> <p>(2) Audio multiplexing applications Depending on the audio multiplexing decoder application, the input impedance is low, which may distort the L-R signals, etc., and degrade the stereo characteristics. In such an event, add a resistor between pin 1 and GND. $R2 \cong 5.1 \text{ k}\Omega$</p>
2	FM AQT FILTER	<p style="text-align: right;">A04200</p>	<p>Pin 2 is the FM Automatic Quadrature Tuning filter pin. This pin controls the quadrature detector so that it remains at its center frequency (4.5 MHz), and is the point where the two control currents are added. If the value of external capacitor C1 is small, the low-range frequency characteristics deteriorate. If the capacitance is too large, the low-range characteristics improve, but the response characteristics at SW-ON, etc., worsen.</p> <p>The recommended value for C1 is 10 μF to 33 μF.</p>
3	RF AGC OUTPUT	<p style="text-align: right;">A04201</p>	<p>Pin 3 is the RF AGC output pin. It is an emitter output, and a protective resistor of 200 Ω is connected between pin 3 and emitter.</p> <p>This pin determines the resistance bleeder (R1, R2) values according to the maximum gain of the tuner.</p>

Continued on next page.

LA7583

Continued from preceding page.

Pin No.	Symbol	Circuit Configuration	Description
4	IF AGC	<p style="text-align: right;">A04202</p>	<p>Pin 4 is the 1st IFAGC filter pin. This filter smoothes out the peaks detected in the signal by the AGC detector, and generates the AGC voltage. The 2nd AGC filter (lag lead filter) is built in using filter technology. The cutoff frequency is approximately 500 Hz.</p> <ul style="list-style-type: none"> AGC filter constants and AGC speed <ul style="list-style-type: none"> Medium-speed AGC: $R1 = 330\text{ k}\Omega$ $C1 = 0.1\text{ }\mu\text{F}$ High-speed AGC: $R1 = 470\text{ k}\Omega$ $C1 = 0.056\text{ }\mu\text{F}$
5 6	VIF INPUT	<p style="text-align: right;">A04203</p>	<p>Pins 5 and 6 are the VIF amplifier input pins. The VIF amplifier has three stages, each of which uses a C cut, so when used in conjunction with a SAW filter, DC cut by a capacitor becomes unnecessary.</p> <p>$R_i = 1.1\text{ k}\Omega$ $C_i = 3\text{ pF}$</p>
9	1st SIF INPUT	<p style="text-align: right;">A04204</p>	<p>Pin 9 is the 1st SIF input pin. Input is such that DC cut must be performed using a capacitor. When a SAW filter, etc. is used in the input circuit, an L that is used to neutralize the SAW filter output capacitance and the IC input capacitance serves to improve the 1st SIF sensitivity.</p>

Continued on next page.

LA7583

Continued from preceding page.

Pin No.	Symbol	Circuit Configuration	Description
10	VCOR	<p style="text-align: right;">A04205</p>	<p>Pin 10 is the pin for connecting the resistor that determines the impedance of the oscillation point of the oscillating circuit by the ceramic oscillator. Oscillation frequency variations can be reduced by connecting a resistor with a tolerance of 1% between pin 10 and pin 12.</p>
11	AFT OUTPUT	<p style="text-align: right;">A04206</p>	<p>Pin 11 is the AFT output pin. This pin determines the gain (control sensitivity: β (kHz/mV)) according to the R1 and R2 bleeder resistance values. β is decreased in weak electric fields by AGC voltage in order to reduce malfunction of AFT. R1 and R2 must be 200 kΩ or less.</p> <div style="text-align: center;"> </div> <p style="text-align: right;">A04207</p>
12	VCO2	<p style="text-align: right;">A04205</p>	<p>Pin 12 is the ceramic oscillator (VCO2) pin. A series resonance-type oscillator is used to oscillate 1/8 of the IF signal.</p> <p>Japan = 58.75 MHz \times 1/8</p> <p>U.S. = 45.75 MHz \times 1/8</p>

Continued on next page.

LA7583

Continued from preceding page.

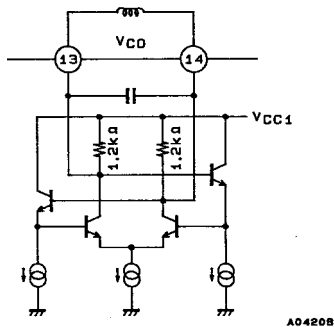
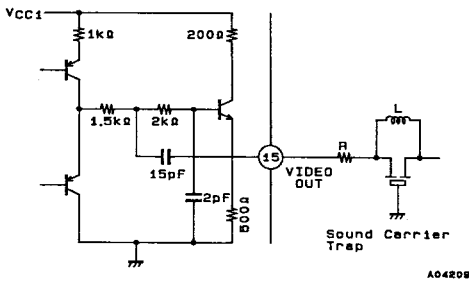
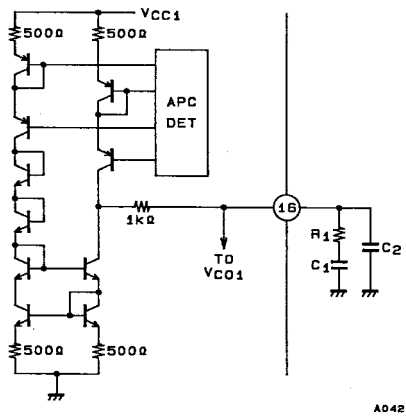
Pin No.	Symbol	Circuit Configuration	Description
13 14	VCO COIL		<p>Pins 13 and 14 are the VCO tank circuit. VCO coil recommended</p> <ul style="list-style-type: none"> • Japan 1.2 μH • U.S. 1.8 μH <p>Make the circuit pattern between the IC and the coil as short as possible.</p>
15	VIDEO OUTPUT		<p>Pin 15 is the SIF carrier (4.5 MHz)-contained video output pin. The level of the video output is approximately 1.5 V_{p-p}.</p>
16	APC1 FILTER		<p>Pin 16 is the APC1 filter pin. The filter smoothes the output after comparing the phase of the IF signal with that of VCO1 in APC1.</p> <p> $C_1 = 0.47 \mu\text{F}$ $R_1 = 330 \text{ to } 560 \Omega$ $C_2 = 470 \text{ pF}$ </p>

Continued on next page.

LA7583

Continued from preceding page.

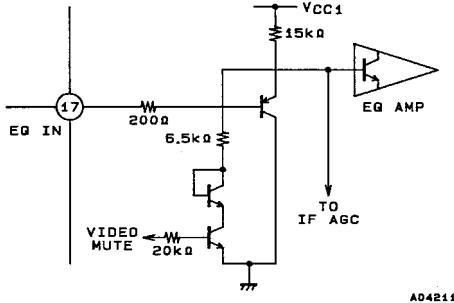
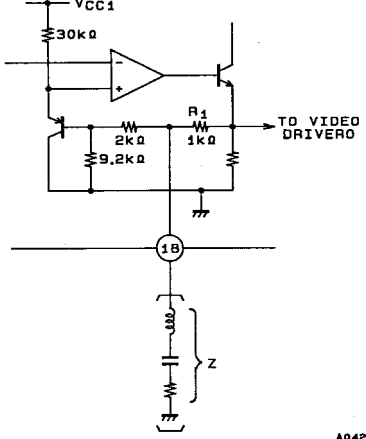
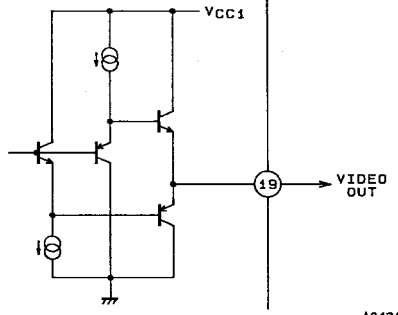
Pin No.	Symbol	Circuit Configuration	Description
17	EQUALIZER INPUT	 <p style="text-align: right;">A04211</p>	<p>Pin 17 is the equalizer amplifier input pin. A signal which has passed through a 4.5 MHz trap is input through pin 17 and is output through pin 19.</p> <ul style="list-style-type: none"> The input level of pin 17 is 1.5 Vp-p. This is amplified 3 dB to 2 Vp-p by the equalizer amplifier.
18	EQUALIZER FILTER	 <p style="text-align: right;">A04212</p>	<p>Pin 18 is the equalizer pin. The equalizer amplifier is of the voltage follower type with a voltage gain of 3 dB. To correct the frequency characteristics, connect LCR externally.</p> <p>The operating characteristics are as follows:</p> $A_v = \frac{V_e}{V_i} = 1 + \frac{R_1}{Z} \text{ (times)}$
19	EQUALIZER OUTPUT	 <p style="text-align: right;">A04213</p>	<p>Pin 19 is the equalizer amplifier output pin. This output has a built-in low-impedance drive circuit.</p>

Continued on next page.

LA7583

Continued from preceding page.

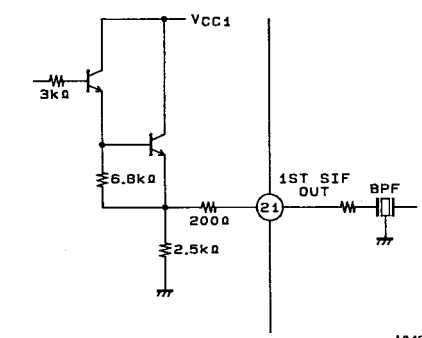
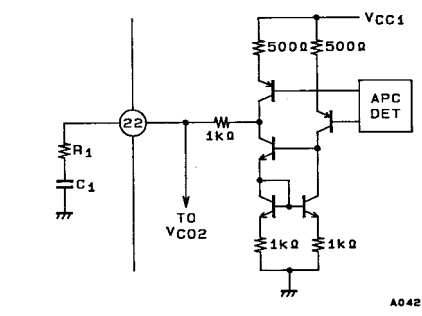
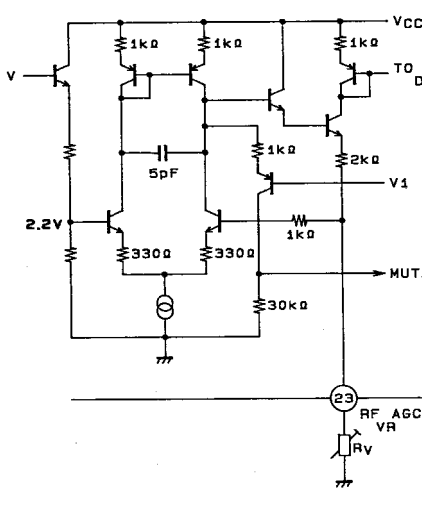
Pin No.	Symbol	Circuit Configuration	Description
21	1st SIFOUT	 <p style="text-align: right;">A04215</p>	<p>Pin 21 is the 1st SIF output pin. The SIF carrier output level is approximately 50 mVrms.</p>
22	APC2 FILTER	 <p style="text-align: right;">A04215</p>	<p>Pin 22 is the APC2 filter pin. The filter smoothes the output after comparing the phase of VC02 with that of VC01 x 1/8 in APC2.</p> <p>$C_1 = 0.47\mu\text{F}$ $R_1 = 33\ \Omega$</p>
23	RF AGC VR	 <p style="text-align: right;">A04217</p>	<p>Pin 23 is the RF AGC adjusting pin. The adjustment point is where Rv approximates 15 kΩ. AV (audio/video) mute is effected by dropping this pin to GND.</p>

Continued on next page.

LA7583

Continued from preceding page.

Pin No.	Symbol	Circuit Configuration	Description
24	SIF INPUT, J/U SW		<p>Pin 24 is used both for SIF input and J/U SW audio mute.</p> <ul style="list-style-type: none"> The input impedance is approximately 1.5 kΩ. J/U (Japan/U.S.) switch The oscillating frequency for VCO2 in Japan and the U.S. differs. However, the center frequency of the SIF detector is controlled using VCO2 as a reference. As a result, the filter control mode can be changed either by leaving this pin open or dropping it to GND through a 3.9 kΩ resistor. Open: Japan mode 3.9 kΩ: U.S. mode Audio mute: Audio muting can be applied by dropping the voltage on this pin to 0.5 V or less.

LA7583 VCO COIL design considerations

1. Design criteria

Allow for an adequate variable range for the IF frequency in the design. Specifically, select a coil value so that the carrier frequency is roughly in the center of the characteristics diagram shown below when 2 V and 4 V are applied to pin 22.

2. Design notes

- When selecting the L value, the LA7583 must be soldered directly on the board. If an IC socket is used, an error in the VCO center frequency will arise from the capacitance of the socket.
- The patterns for pins 13 and 14 must be made as short as possible (15 mm or less). Minimize the effect of the printed pattern.
- A VCO coil of which tolerance is $\pm 5\%$ must be used.

3. Measuring the IF frequency range

Drop the IF AGC (pin 4) to GND. Next, pick up the VCO carrier leak at a pin other than the VCO coil (pins 13 and 14) and read the carrier frequency. And then, apply a voltage ranging from 1.5 V to 4.5 V to pin 22, and record the characteristics of the maximum variable frequency range for VCO as shown in the diagram below.

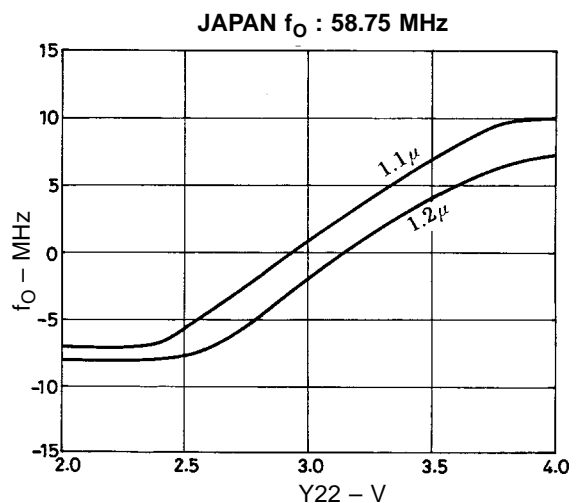
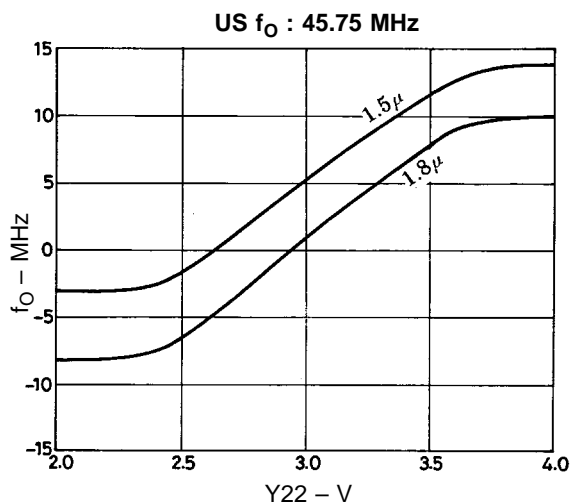

4. Recommended VCO coil

- | | | | |
|-----------------------------------|-----|-------|---------------------------|
| A. Tokyo Parts Industry Co., Ltd. | 5LC | JAPAN | 1.2 $\mu\text{H} \pm 5\%$ |
| | | U.S. | 1.8 $\mu\text{H} \pm 5\%$ |

Notes on Sanyo SAW Filters

There are two types of filters, depending on the piezoelectric substrate material.

- (1) LiTaO₃ (lithium tantalate) SAW filters:TSF1xxx
 TSF2xxx

While the LiTaO₃ SAW filters offer excellent stability with a low temperature coefficient of $-18 \text{ ppm}/^\circ\text{C}$, the insertion loss is high. However, by using a coil, etc., to obtain proper matching on the SAW filter output side (which does increase the number of external components), it is possible to suppress the insertion loss while at the same time making the level of the characteristics variable, which provides additional design freedom. (Refer to Fig. 13.) In addition, because the SAW (surface wave) reflection is small, ripple within the band can be kept low.

- (2) LiNbO₃ (lithium niobate) SAW filter:TSF5xxx

While the LiNbO₃ SAW filter has a high temperature coefficient of $-72 \text{ ppm}/^\circ\text{C}$, it has a lower insertion loss by about 10 dB compared to the LiTaO₃ SAW filters. Therefore, matching on the output side of the SAW filter is not necessary. (Refer to the diagram below.) In addition, because the insertion loss is low (although the ripple within the band is somewhat higher than in the case of the LiTaO₃ SAW filter), the low impedance and small feedthrough diminish the effects of peripheral circuit components and the pattern layout, and make it possible to stabilize the trap characteristics outside of the band.

From the above, it is clear that the LiTaO₃ SAW filter is suitable for Japan and U.S. bands where the IF frequency is high, while the LiNbO₃ SAW filter is suitable for PAL and U.S. bands where the IF frequency is low.

LiTaO₃ SAW Filter

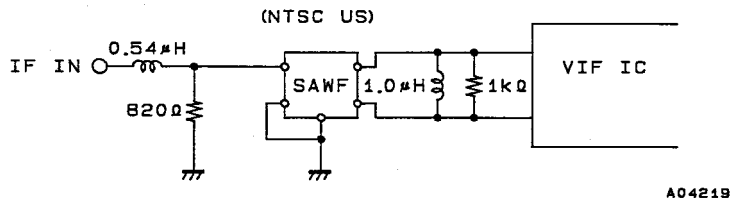

LiNbO₃ SAW Filter

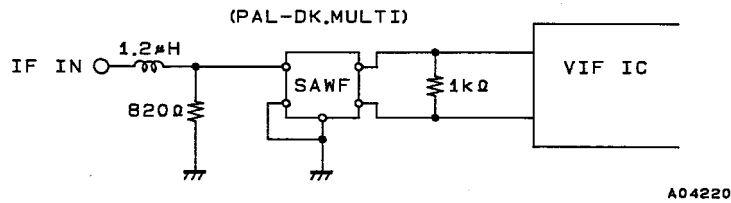

- (a) Picture wide BAND SAW Filter
 Japan TSF1137U
 U.S. TSF1241U(with IS-31 Trap)
- (b) INTER Carrier SAW Filter
 Japan TSF1138P
 U.S. TSF1220P

LA7583

Test circuit Diagram

LA7583 (U.S.)

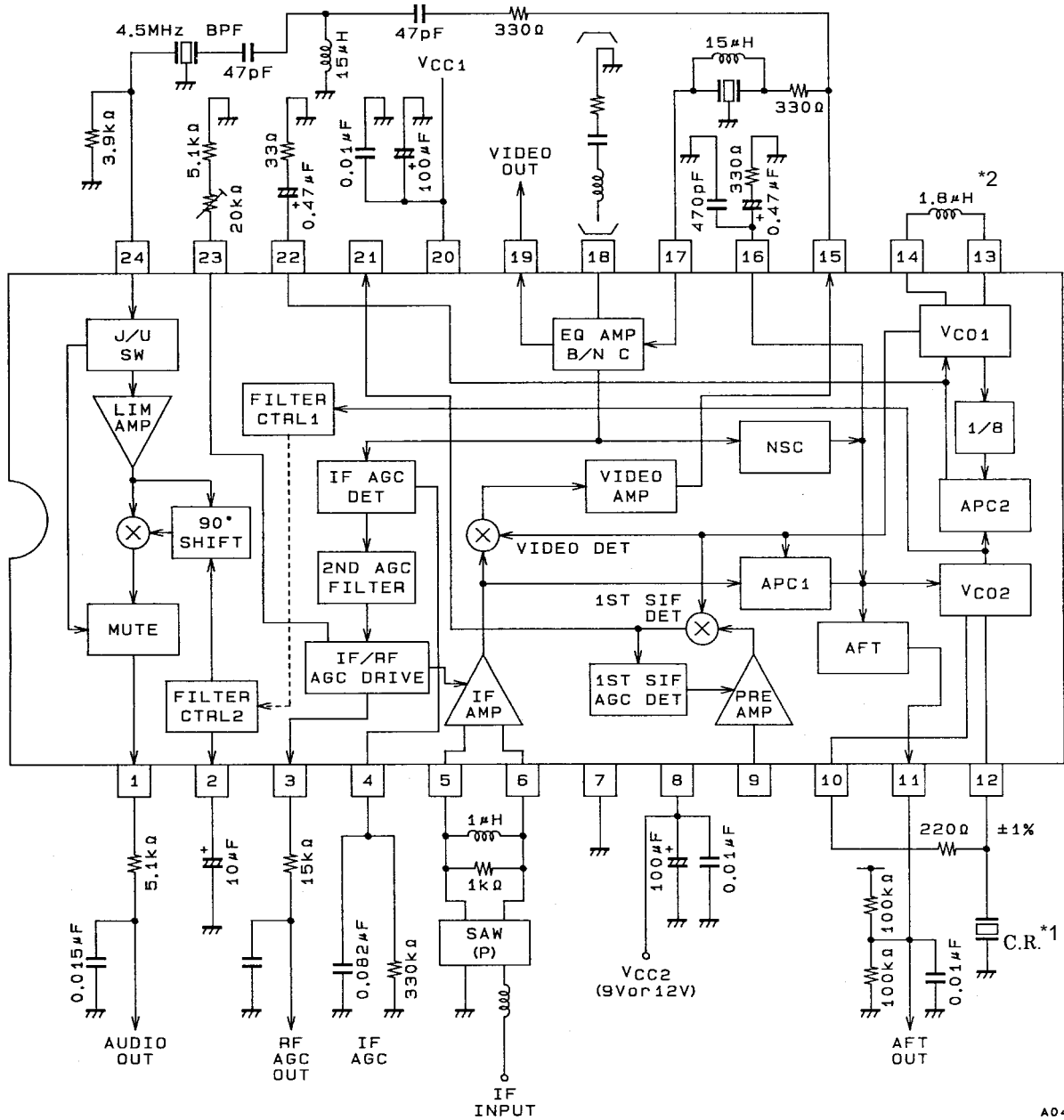

*1. TDK ceramic oscillator FCR5.71M2SF3

*2. Micro-inductor 5LC1R8, made by Tokyo Parts Industry Co., Ltd.

A04221

- Specifications of any and all SANYO products described or contained herein stipulate the performance, characteristics, and functions of the described products in the independent state, and are not guarantees of the performance, characteristics, and functions of the described products as mounted in the customer's products or equipment. To verify symptoms and states that cannot be evaluated in an independent device, the customer should always evaluate and test devices mounted in the customer's products or equipment.
- SANYO Electric Co., Ltd. strives to supply high-quality high-reliability products. However, any and all semiconductor products fail with some probability. It is possible that these probabilistic failures could give rise to accidents or events that could endanger human lives, that could give rise to smoke or fire, or that could cause damage to other property. When designing equipment, adopt safety measures so that these kinds of accidents or events cannot occur. Such measures include but are not limited to protective circuits and error prevention circuits for safe design, redundant design, and structural design.
- In the event that any or all SANYO products(including technical data, services) described or contained herein are controlled under any of applicable local export control laws and regulations, such products must not be exported without obtaining the export license from the authorities concerned in accordance with the above law.
- No part of this publication may be reproduced or transmitted in any form or by any means, electronic or mechanical, including photocopying and recording, or any information storage or retrieval system, or otherwise, without the prior written permission of SANYO Electric Co., Ltd.
- Any and all information described or contained herein are subject to change without notice due to product/technology improvement, etc. When designing equipment, refer to the "Delivery Specification" for the SANYO product that you intend to use.
- Information (including circuit diagrams and circuit parameters) herein is for example only ; it is not guaranteed for volume production. SANYO believes information herein is accurate and reliable, but no guarantees are made or implied regarding its use or any infringements of intellectual property rights or other rights of third parties.

This catalog provides information as of August, 1995. Specifications and information herein are subject to change without notice.