



LA6503

CD-ROM Drive Spindle Motor Driver + Sled Motor Driver + Sled Motion/Position Detector IC

Overview

The LA6503 was developed for CAV control CD-ROM drives, and provides spindle motor driver, sled motor driver, and sled motion/position detection circuits.

Functions and Features

- CAV control spindle motor driver
 - Three-phase brushless motor driver
 - $I_{Omax} = 1\text{ A}$
 - Built-in FG output circuit (single Hall detection output)
 - Reverse braking circuit
 - Built-in start/stop circuit
 - Upper side current detection for minimal loss in the current detection resistor. Also, the voltage drop in this resistor reduces the IC internal power dissipation.
 - Built-in thermal shutdown circuit
- Sled motor driver
 - One built-in BTL driver channel
 - $I_{Omax} = 1\text{ A}$
 - Wide dynamic range
 - Built-in level shifting circuit
 - Muting (output on/off) circuit
 - Built-in thermal shutdown circuit
- Sled motion/position detection circuit
 - Circuit that provides a pulse output corresponding to sled motion and position
 - This circuit emits 96 pulses for each rotation from a 24-pole magnet and 90° phase difference Hall element motors, and thus detects the distance moved. It also provides two 48-pulse outputs with differing phases such that the motion direction can be detected from the phase difference between those signals.
- Hall bias power supply
 - Generates the Hall element 3-V bias voltage.
 - $I_{Omax} = 30\text{ mA}$, typical

Package Dimensions

unit: mm

3219-QFP34H-C

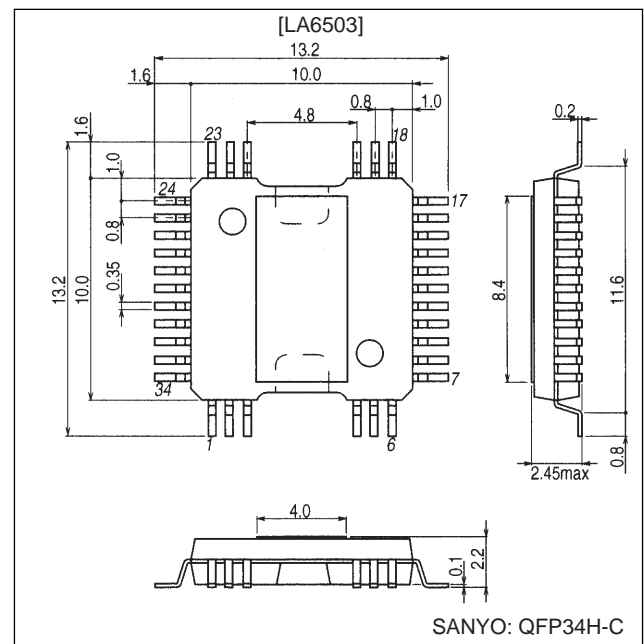

Specifications

Maximum Ratings at Ta = 25°C

Parameter	Symbol	Conditions	Ratings	Unit
Supply voltage	V _{CC} max		7	V
Supply voltage	V _M max		14	V
Input voltage	V _C max		V _{CC}	V
Output current	I _O max	Spindle output, sled output	1	A
Allowable power dissipation	Pd max	Independent IC	0.77	W
Operating temperature	Topr		-20 to +75	°C
Storage temperature	Tstg		-55 to +150	°C

Operating Conditions at Ta = 25°C

Parameter	Symbol	Conditions	Ratings	Unit
Operating supply voltage range	V _{CC}		4.6 to 6.0	V
	V _M		4.6 to 13.0	V

Operating Characteristics at Ta = 25°C, V_{CC} = 5 V, V_M = 12 V (unless otherwise specified)

Parameter	Symbol	Conditions	Ratings			Unit
			min	typ	max	
[Power Supply Current]						
Current drain 1 (V _{CC})	I _{CC1}	START/STOP = MUTE = 5 V		10	20	mA
Current drain 2 (V _M)	I _{M1}	START/STOP = MUTE = 5 V		25	50	mA
Quiescent current 1 (V _{CC})	I _{CC2}	START/STOP = MUTE = 0 V		5	10	mA
Quiescent current 2 (V _M)	I _{M2}	START/STOP = MUTE = 0 V		1	5	mA
[Spindle Motor Block]						
[Output]						
Upper side saturation voltage 1	V _{source}	I _O = -0.5 A		1.0	1.5	V
Lower side saturation voltage 1	V _{sink}	I _O = +0.5 A		0.33	0.80	V
Current limiter voltage setting	V _{CL}	R _{RE} = 0.43 Ω		0.32		V
[Hall Amplifier]						
Common-mode input voltage range	V _{HCOM}		1.2		V _{CC} - 1.0	V
Input bias current	V _{HIB}			1		μA
Minimum Hall input level	V _{HIN}		60			mVp-p
[S/S Pin]						
High-level voltage	VS/SH		2.0		V _{CC}	V
Low-level voltage	VS/SL				0.7	V
Input current	IS/SI	VS/S = 5 V			200	μA
Leakage current	IS/SL	VS/S = 0 V	-30			μA
[Control]						
VC pin input current	I _{VC}	V _C = V _{CREF} = 2.5 V		1	5	μA
V _{CREF} pin input current	I _{V_{CREF}}	V _C = V _{CREF} = 2.5 V		1	5	μA
Voltage gain	G _{VCO}	ΔV _{RF} /ΔV _C		0.25		Times
Rising edge threshold voltage	V _{CTH}	V _{CREF} = 2.5 V	2.35		2.65	V
Rising edge threshold voltage difference	ΔV _{CTH}	V _{CREF} = 2.5 V	50		150	mV
[Hall Comparator]						
Input offset voltage	V _{HCI} OFFSET				10	mV
Input hysteresis	V _{HCI} HYS			8		mV
Output on voltage	V _{OU}				0.3	V
Output off voltage	V _{OD}	*	4.7			V
Output current (sink)	I _{sink}		3			mA

Continued on next page.

LA6503

Continued from preceding page.

Parameter	Symbol	Conditions	Ratings			Unit
			min	typ	max	
[Sled Motor Block]						
Output offset voltage	V_{OFF}	Voltage difference between outputs	-50		+50	mV
Buffer input voltage range	V_{BIN}		1.5		$V_{CC} - 1.5$	V
Input voltage range	V_{IN}		1.0		$V_{CC} - 1.5$	V
Source output voltage	V_{O1}	$R_L = 8 \Omega$	9.5	10.1		V
Sink output voltage	V_{O2}	$R_L = 8 \Omega$		1.8	2.4	V
Closed-circuit voltage gain	VG	Bridge Amp		12		dB
Slew rate	S_R			0.15		V/ μ s
Muting on voltage	V_{MUTE}	The amplifier output is on when at the high level.	0.7	1.2	2.0	V
[Hall Bias (3-V Output Power Supply)]						
Output voltage	V_{HB-OUT}	$I_{OUT} = 30 \text{ mA}$	2.5	3.0	3.5	V
Line regulation	V_{HB-LIN}	$V_{CC} = 4.6 \text{ to } 6 \text{ V}$, $I_{OUT} = 30 \text{ mA}$	-50		+50	mV
Load regulation	$V_{HB-LOAD}$	$I_{OUT} = 5 \text{ to } 30 \text{ mA}$, $V_{CC} = 5 \text{ V}$	-200		+200	mV

Note: For items marked with an asterisk (*), the Hall comparator goes to the high level when the S/S pin is off (standby mode).

Truth Table

(Spindle Motor Block)

	Source → Sink	Input			Control VC
		U	V	W	
1	W → V	H	H	L	H
	V → W				L
2	W → U	H	L	L	H
	U → W				L
3	V → W	L	L	H	H
	W → V				L
4	U → V	L	H	L	H
	V → U				L
5	V → U	H	L	H	H
	U → V				L
6	U → W	L	H	H	H
	W → U				L

Inputs: The "H" state is when the + input of the corresponding phase is 0.2 V or more higher than the - input.
The "L" state is when the + input of the corresponding phase is 0.2 V or more lower than the - input.

(Sled Motor Block)

Input (V_{IN})	Mute	Output	
		SLD-OUT+	SLD-OUT-
H	H	H	L
	L	—	—
L	H	L	H
	L	—	—

Note: "—" indicates that the amplifier output is off.

LA6503

Pin Assignment

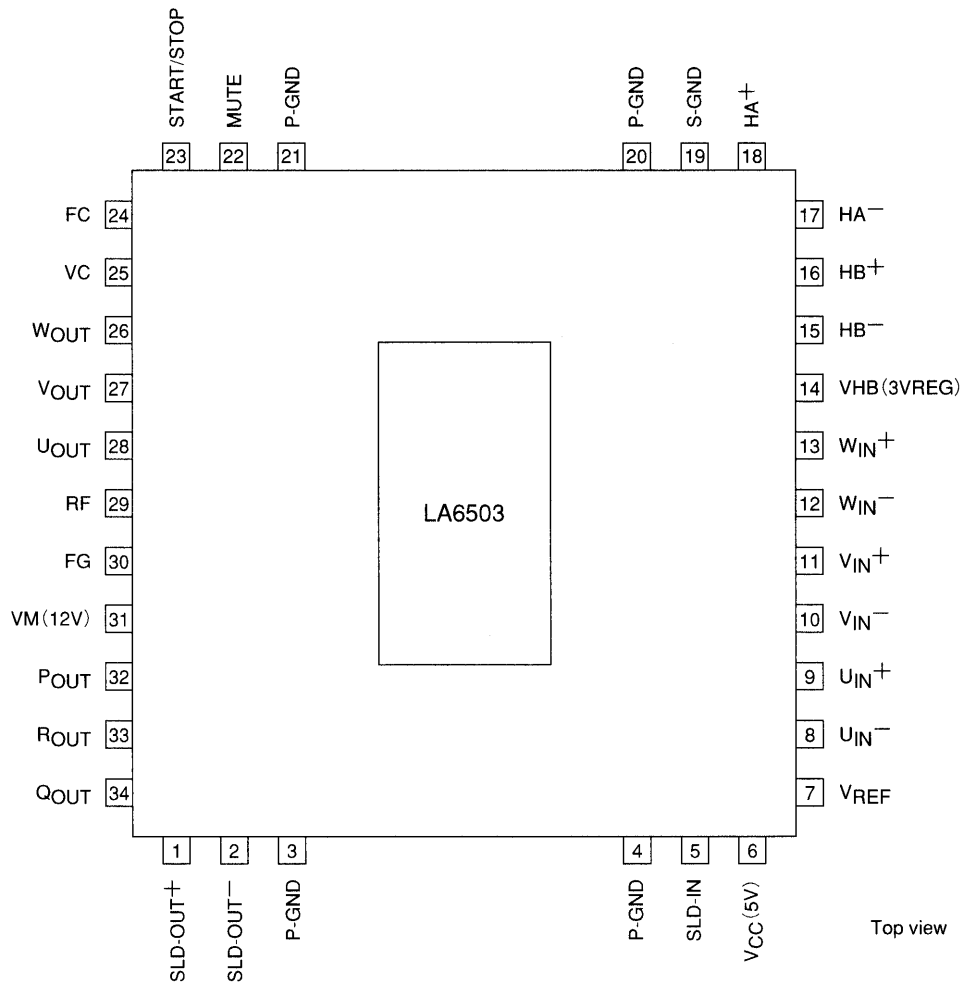

A09788

LA6503

Pin Functions

Pin No.	Symbol	Function
1	SLED OUT ⁺	Sled motor noninverted output
2	SLED OUT ⁻	Sled motor inverted output
3	P-GND	Power system ground
4	P-GND	Power system ground
5	SLED-IN	Sled motor signal input (The gain is set with a resistor.)
6	V _{CC} (5 V)	Signal system power supply (5 V)
7	V _{REF}	Reference voltage input
8	U _{IN} ⁻	Three-phase spindle motor hall signal input pin (U phase -)
9	U _{IN} ⁺	Three-phase spindle motor hall signal input pin (U phase +)
10	V _{IN} ⁻	Three-phase spindle motor hall signal input pin (V phase -)
11	V _{IN} ⁺	Three-phase spindle motor hall signal input pin (V phase +)
12	W _{IN} ⁻	Three-phase spindle motor hall signal input pin (W phase -)
13	W _{IN} ⁺	Three-phase spindle motor hall signal input pin (W phase +)
14	VHB (3Vreg)	Hall bias output pin (3-V power supply output)
15	HB ⁻	Sled motion distance detection hall element input (HB -)
16	HB ⁺	Sled motion distance detection hall element input (HB +)
17	HA ⁻	Sled motion distance detection hall element input (HA -)
18	HA ⁺	Sled motion distance detection hall element input (HA +)
19	S-GND	Signal system ground
20	P-GND	Power system ground
21	P-GND	Power system ground
22	MUTE	Sled motor output muting (output on/off control)
23	START/STOP	Spindle motor output start/stop (output on/off control)
24	FC	Phase compensation capacitor connection
25	VC	Input for the spindle control signal from the ASP
26	WO _{UT}	Three-phase spindle motor output (W phase output)
27	VO _{UT}	Three-phase spindle motor output (V phase output)
28	UO _{UT}	Three-phase spindle motor output (U phase output)
29	RF	Output current detection
30	FG	FG signal output
31	V _M (12 V)	Motor power supply (12 V)
32	PO _{UT}	Sled motion position detection pulse output P (96 pulses)
33	RO _{UT}	Sled motion position detection pulse output R (48 pulses)
34	QO _{UT}	Sled motion position detection pulse output Q (48 pulses)

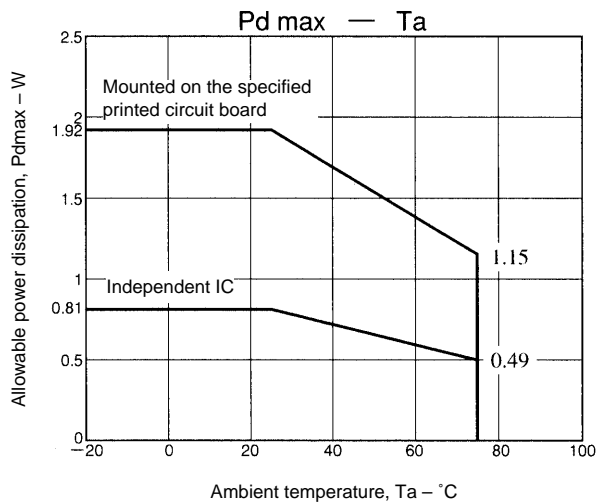

Block Diagram

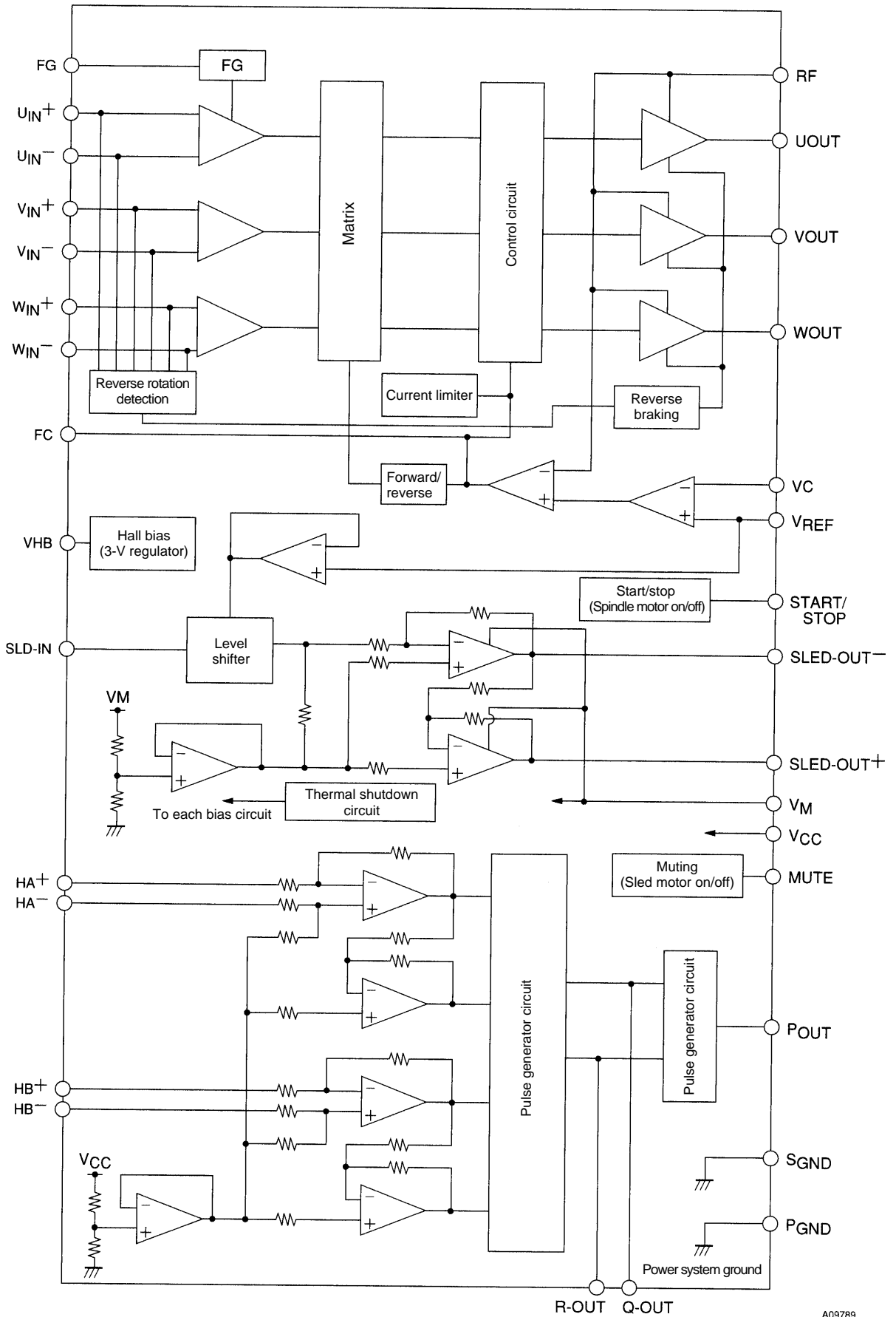

A09789

Notes on Gain Adjustment (Sled Motor Block)

- Gain setting

The sled motor block gain is set using an external resistor as shown below.

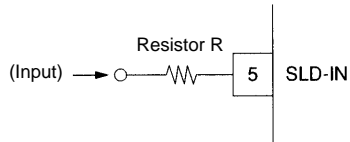

A09790

For example, when the external resistor R is $22\text{ k}\Omega$, the gain will be 0 dB when seen as an independent output amplifier and 6 dB when seen as a BTL circuit (between outputs). Referenced to this $22\text{-k}\Omega$ resistor, the independent output amplifier gain will be $22\text{k}/R$ (as a multiple) or $20\log(22\text{k}/R)\text{ dB}$. Similarly, the BTL gain will be $2\times 22\text{k}/R$ (as a multiple) or $20\log(22\text{k}/R)\text{ dB} + 3\text{ dB}$. The level shifting circuits used in current models perform both current and voltage conversion, and thus have a different input type from normal operational amplifiers. The current that flows in the external resistor, that is, the potential difference, becomes the input to AMP1 and AMP2.

- Output offset voltage

The output offset voltage is $1/2 V_M$ (typical). The V_O^- and V_O^+ outputs are converted to outputs that are centered on this voltage.

Sled Position Detection Pulse Waveforms

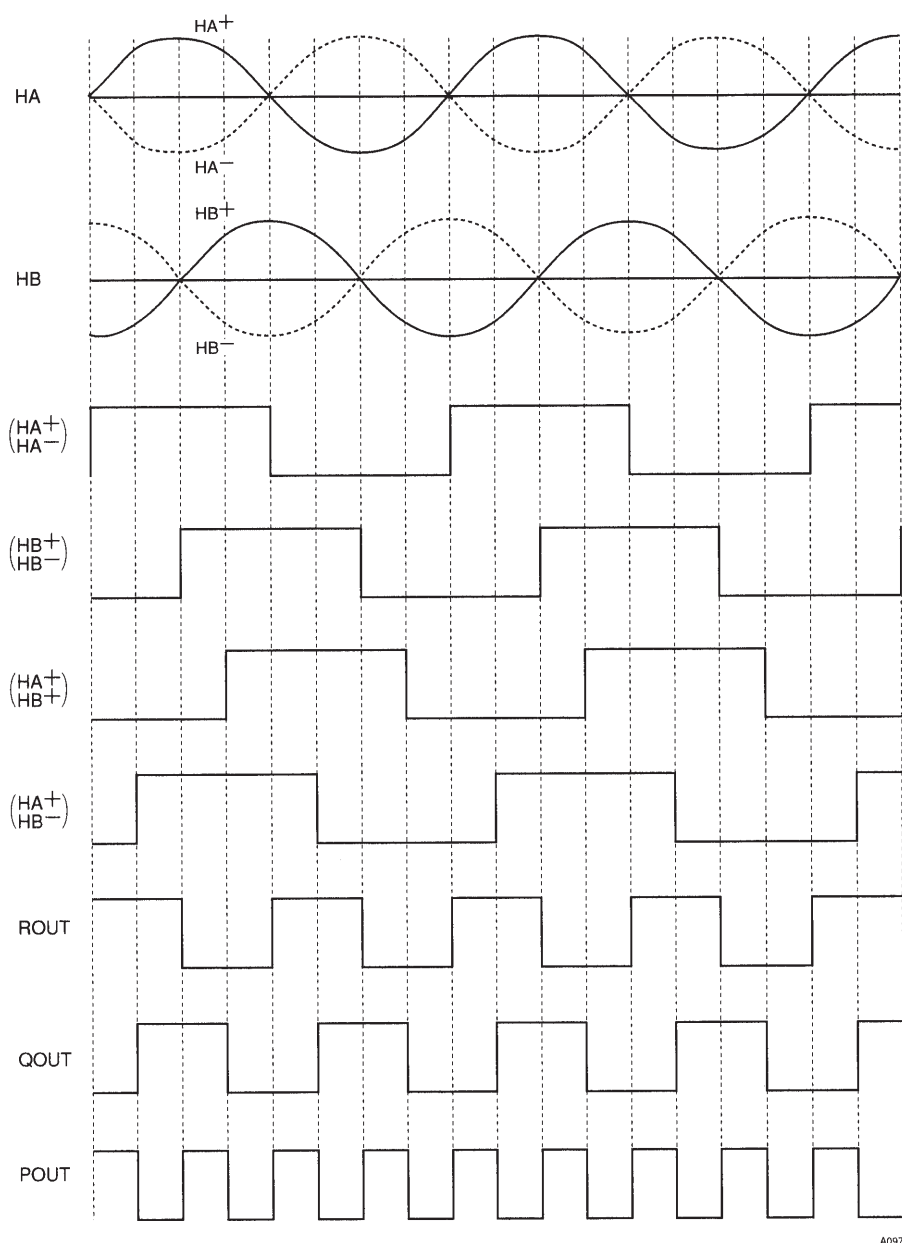

A09791

Note: When the sled motor rotation direction changes (that is, when the HA and HB phase relationship changes), the R-OUT and Q-OUT phase relationship changes and the direction can be detected from that phase. The motion distance and position are detected from P-OUT.

- No products described or contained herein are intended for use in surgical implants, life-support systems, aerospace equipment, nuclear power control systems, vehicles, disaster/crime-prevention equipment and the like, the failure of which may directly or indirectly cause injury, death or property loss.
- Anyone purchasing any products described or contained herein for an above-mentioned use shall:
 - ① Accept full responsibility and indemnify and defend SANYO ELECTRIC CO., LTD., its affiliates, subsidiaries and distributors and all their officers and employees, jointly and severally, against any and all claims and litigation and all damages, cost and expenses associated with such use:
 - ② Not impose any responsibility for any fault or negligence which may be cited in any such claim or litigation on SANYO ELECTRIC CO., LTD., its affiliates, subsidiaries and distributors or any of their officers and employees jointly or severally.
- Information (including circuit diagrams and circuit parameters) herein is for example only; it is not guaranteed for volume production. SANYO believes information herein is accurate and reliable, but no guarantees are made or implied regarding its use or any infringements of intellectual property rights or other rights of third parties.

This catalog provides information as of March, 1998. Specifications and information herein are subject to change without notice.