



LA1185

FM Front-end for Radio-cassette Recorder, Home Stereo Applications

Overview

The LA1185 is an FM receiver front-end IC for radio-cassette recorder, music center applications. Its mixer is of double-balanced type. The built-in oscillator and buffer amplifier improves the strong input characteristic.

Use

- FM front-end IC for radio-cassette recorders and music centers

Functions and Features

- RF amplifier, mixer, local oscillator
- Improvement in cross modulation characteristics due to the use of double-balanced mixer.
- Improvement in strong input characteristic.
- Minimum number of external parts required.
- Less spurious radiation from local oscillator.
- Operating voltage range : 1.5 to 8.0 V

Specifications

Maximum Ratings at $T_a = 25^\circ\text{C}$

Parameter	Symbol	Conditions	Ratings	Unit
Maximum supply voltage	V_{CC} max		8	V
Maximum pin voltage	V_{3-5}		12	V
	V_{6-5}		$V_{CC} + 0.8$	V
Allowable power dissipation	P_d max	$T_a \leq 80^\circ\text{C}$	150	mW
Operating temperature	T_{opr}		-20 to +80	$^\circ\text{C}$
Storage temperature	T_{stg}		-40 to +125	$^\circ\text{C}$

Package Dimensions

unit : mm

3017C-SIP9

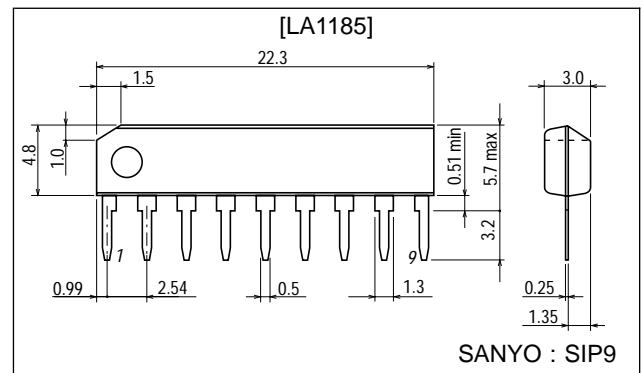

■ Any and all SANYO products described or contained herein do not have specifications that can handle applications that require extremely high levels of reliability, such as life-support systems, aircraft's control systems, or other applications whose failure can be reasonably expected to result in serious physical and/or material damage. Consult with your SANYO representative nearest you before using any SANYO products described or contained herein in such applications.

■ SANYO assumes no responsibility for equipment failures that result from using products at values that exceed, even momentarily, rated values (such as maximum ratings, operating condition ranges, or other parameters) listed in products specifications of any and all SANYO products described or contained herein.

SANYO Electric Co., Ltd. Semiconductor Company

TOKYO OFFICE Tokyo Bldg., 1-10, 1 Chome, Ueno, Taito-ku, TOKYO, 110-8534 JAPAN

LA1185

Operating Conditions at $T_a = 25^\circ\text{C}$

Parameter	Symbol	Conditions	Ratings	Unit
Recommended supply voltage	V_{CC}		4.5	V
Operating voltage range	V_{CCop}		1.5 to 8.0	V

Operating Characteristics at $T_a = 25^\circ\text{C}$, $V_{CC} = 4.5\text{ V}$, $f_r = 108\text{ MHz}$, $f_{OSC} = 118.7\text{ MHz}$, See specified Test Circuit

Parameter	Symbol	Conditions	min	typ	max	Unit
Current dissipation	I_{CC}	Quiescent		5.5	8.0	mA
Output saturation voltage	V_o	100 dB μ	95	115	135	mVrms
Local oscillation voltage	V_{OSC}	$V_{CC} = 2\text{ V}$	190	235		mVrms
Oscillation stop voltage	V_{stop}			1.4	1.6	V

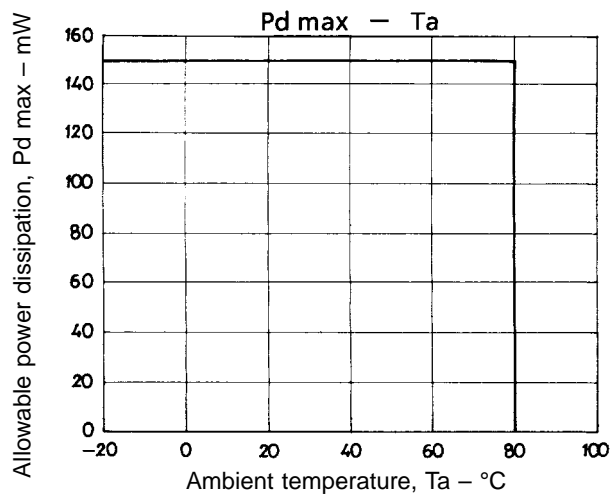

Test Circuit and Equivalent Circuit Block Diagram

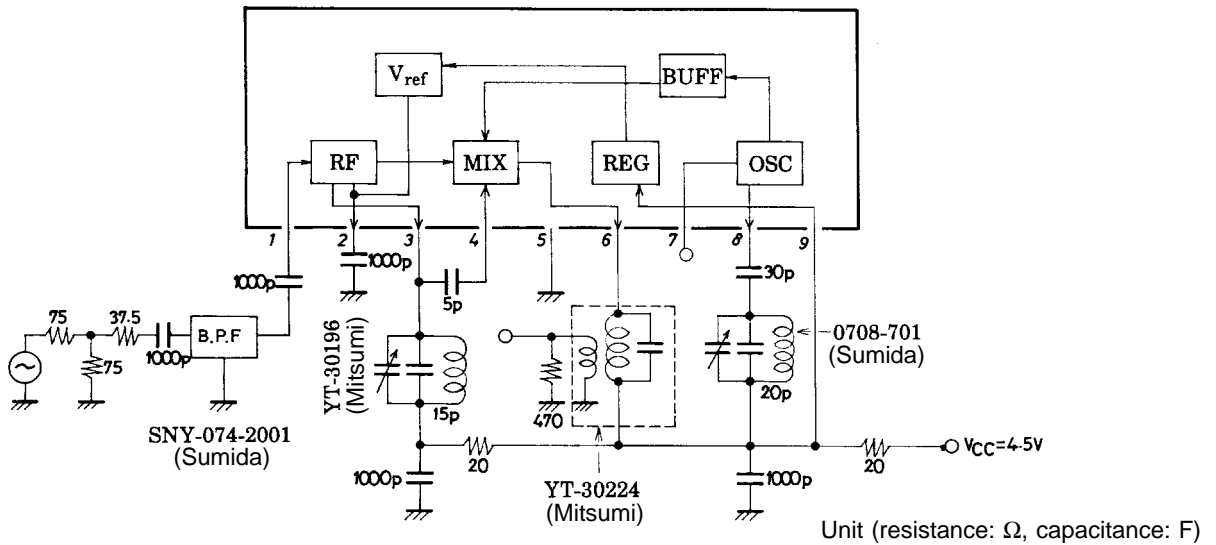

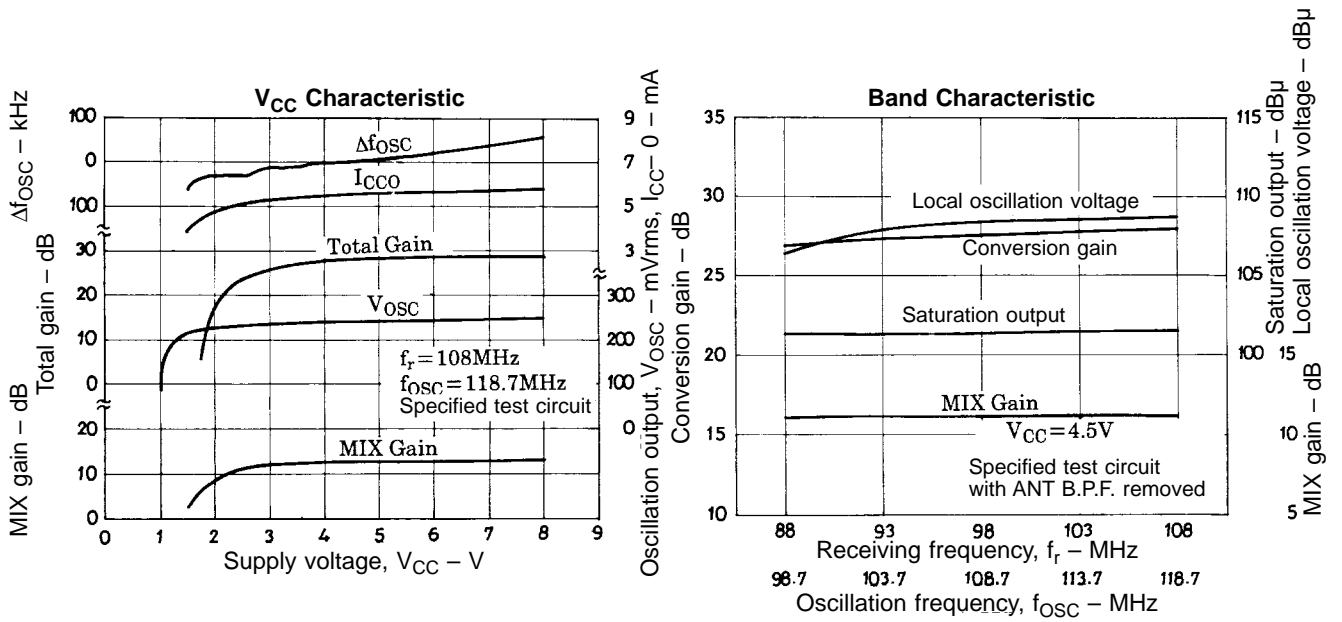

Temperature Characteristic Test Circuit

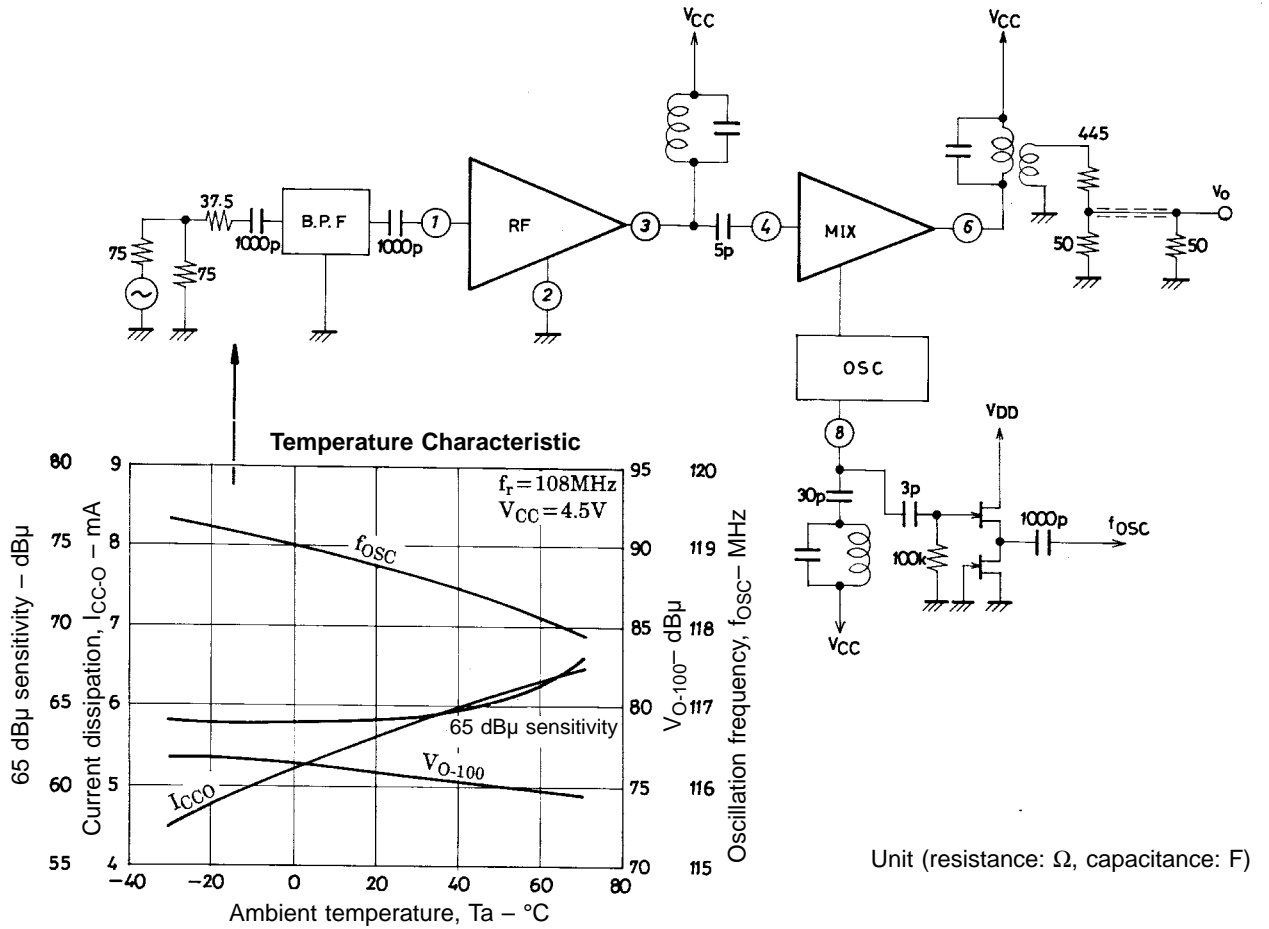

LA1185

Sample Application Circuit: LA1185 + LA1260 US band

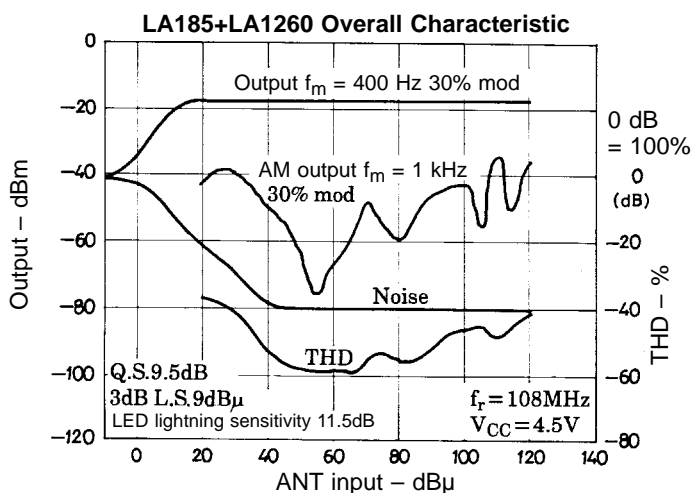
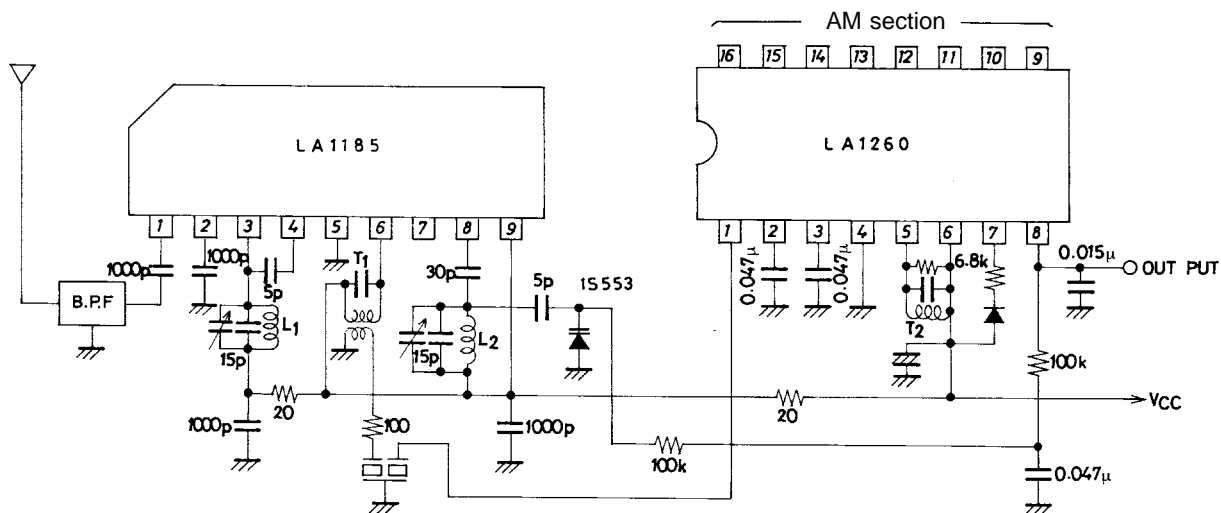

Unit (resistance: Ω , capacitance: F)

	Mitsumi	Sumida
T1	YT-30224	2153-4016-006
T2	YT-30194	2153-4095-339
L1	YT-30196	0708-700
L2	YT-40001	0708-701
B.P.F.	YT-30025	SNY-074-2001

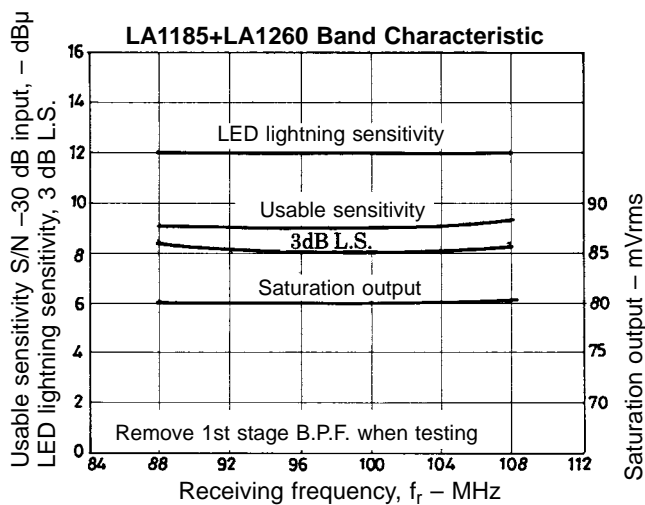

- Specifications of any and all SANYO products described or contained herein stipulate the performance, characteristics, and functions of the described products in the independent state, and are not guarantees of the performance, characteristics, and functions of the described products as mounted in the customer's products or equipment. To verify symptoms and states that cannot be evaluated in an independent device, the customer should always evaluate and test devices mounted in the customer's products or equipment.
- SANYO Electric Co., Ltd. strives to supply high-quality high-reliability products. However, any and all semiconductor products fail with some probability. It is possible that these probabilistic failures could give rise to accidents or events that could endanger human lives, that could give rise to smoke or fire, or that could cause damage to other property. When designing equipment, adopt safety measures so that these kinds of accidents or events cannot occur. Such measures include but are not limited to protective circuits and error prevention circuits for safe design, redundant design, and structural design.
- In the event that any or all SANYO products(including technical data, services) described or contained herein are controlled under any of applicable local export control laws and regulations, such products must not be exported without obtaining the export license from the authorities concerned in accordance with the above law.
- No part of this publication may be reproduced or transmitted in any form or by any means, electronic or mechanical, including photocopying and recording, or any information storage or retrieval system, or otherwise, without the prior written permission of SANYO Electric Co., Ltd.
- Any and all information described or contained herein are subject to change without notice due to product/technology improvement, etc. When designing equipment, refer to the "Delivery Specification" for the SANYO product that you intend to use.
- Information (including circuit diagrams and circuit parameters) herein is for example only ; it is not guaranteed for volume production. SANYO believes information herein is accurate and reliable, but no guarantees are made or implied regarding its use or any infringements of intellectual property rights or other rights of third parties.

This catalog provides information as of August, 1996. Specifications and information herein are subject to change without notice.