

100V/5A STEP AND MICROSTEP DRIVE BOARD FOR STEPPER MOTORS

FEATURES

- 100V Operating Supply Voltage
- 5A/phase peak current
- 5, 25, 125 microsteps/step
- Full step and half step operation
- User selectable phase current
- 90° out of phase chopping to save power consumption
- Galvanic isolation
- Full output protection against short-circuits
- Thermal and undervoltage protection
- Step clock in excess of 200kHz
- Fault indication output
- Special circuit to reduce midrange instability

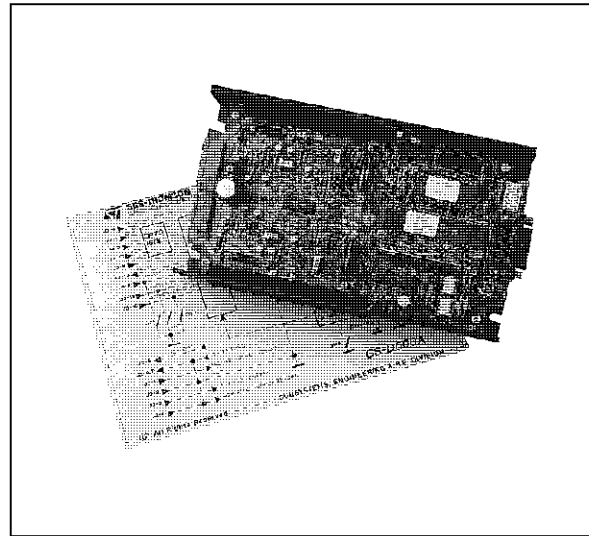

DESCRIPTION

The GS-D500A is a member of the SGS-THOMSON family of stepper motor driver modules and boards. It drives motors in full step, half step and microstep mode.

On top of that it offers an unusually large number of features that allow a complete control of the

electromechanical characteristics of the motion system to obtain optimum performance.

The powermos output stages offer both low conduction and commutation losses for increased efficiency; this, combined with a complete protection scheme, results in an extremely rugged unit suitable for harsh environment operation.

ABSOLUTE MAXIMUM RATINGS

Symbol	Parameter	Value	Unit
V _s	DC Supply Voltage	110	V
V _{ss}	DC Logic Supply Voltage	13	V
I _{ph}	Output Current per Bridge	6	Apk
I _i	Logic Input Current	30	mA
V _{is}	Isolation Voltage	500	V
T _{stg}	Storage Temperature Range	- 20 to +85	°C
T _{hop}	Operating Heatsink Temperature	+85	°C

Note: Absolute maximum ratings are limit values above which the unit can be permanently damaged
 * Thermal protection intervention @ T_h > 90°C

ELECTRICAL CHARACTERISTICS ($T_{amb} = 25^{\circ}\text{C}$ and $V_s = 24\text{V}$ unless otherwise specified)

Symbol	Parameter	Test Conditions	Min	Typ	Max	Unit
V_s	DC Supply Voltage		12		100	V
V_{ss}	DC Logic Supply Voltage		11.5	12	12.5	V
I_{ph}	Phase Current per Output*		0.5		5	A
I_i	Logic Input Current			10		mA
V_{sl}	On board Logic Supply Output		4.75	5	5.25	V
I_{osl}	On board Logic Supply Current Output				100	mA
f_c	Clock Pulse Frequency				200	kHz

* Output Shorts Protection phase-to-phase, phase-to-ground.
 Note: the unit requires an input filtering capacitor in the range of 4700 to 10000 $\mu\text{F}/100\text{V}$, with low ESR and located as close as possible to the board.

Figure 1. Signals timing

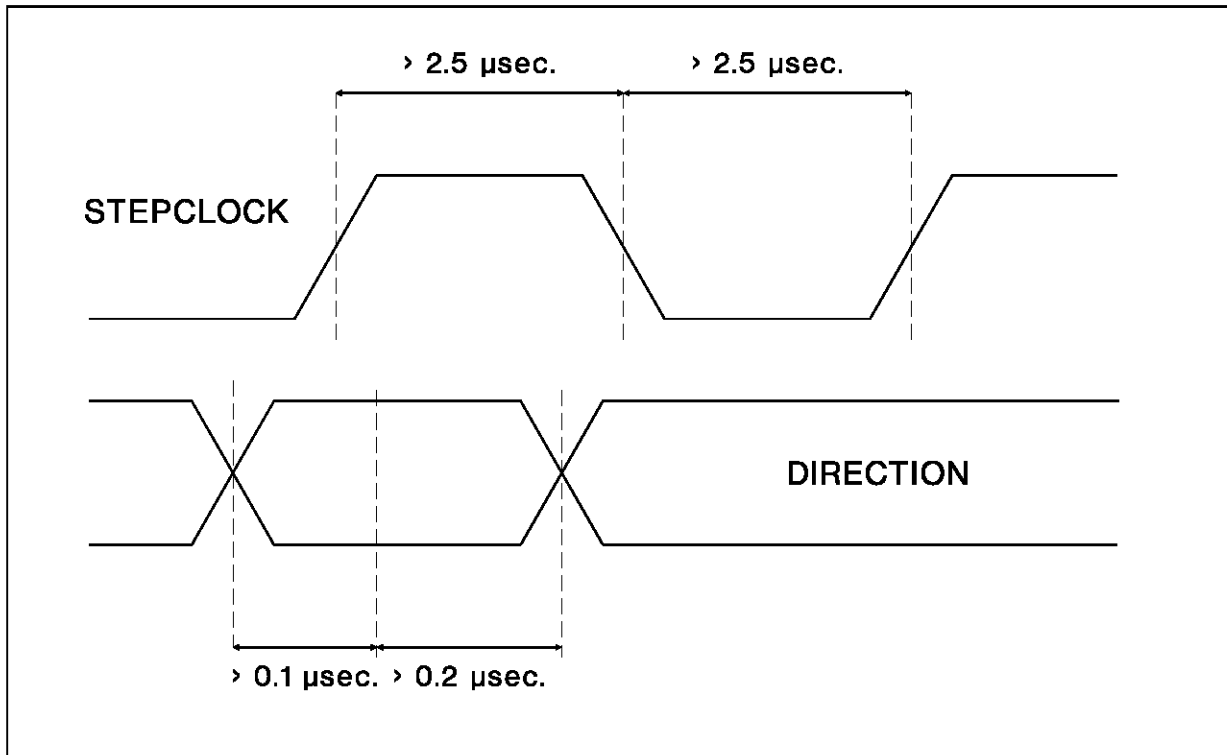
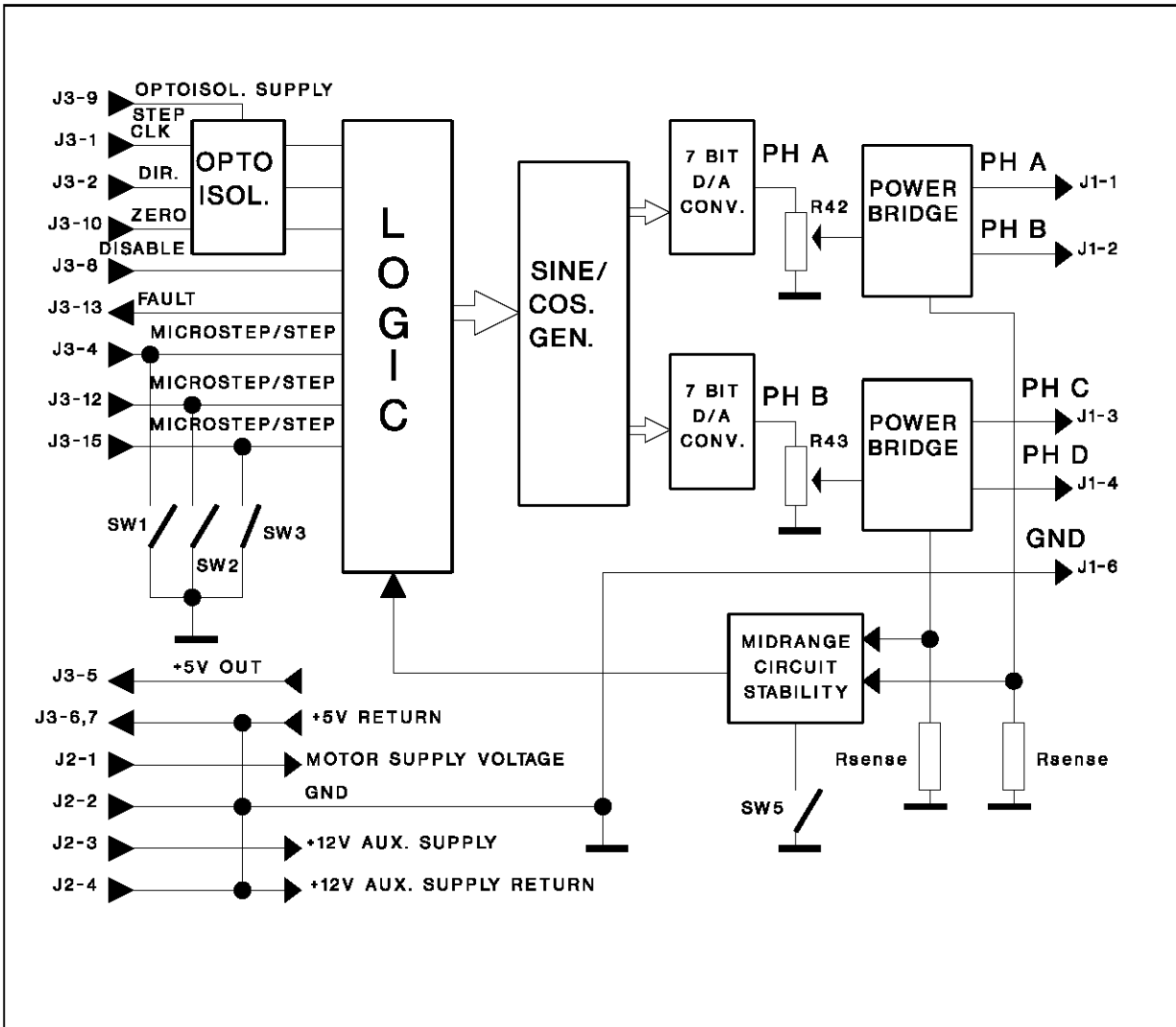
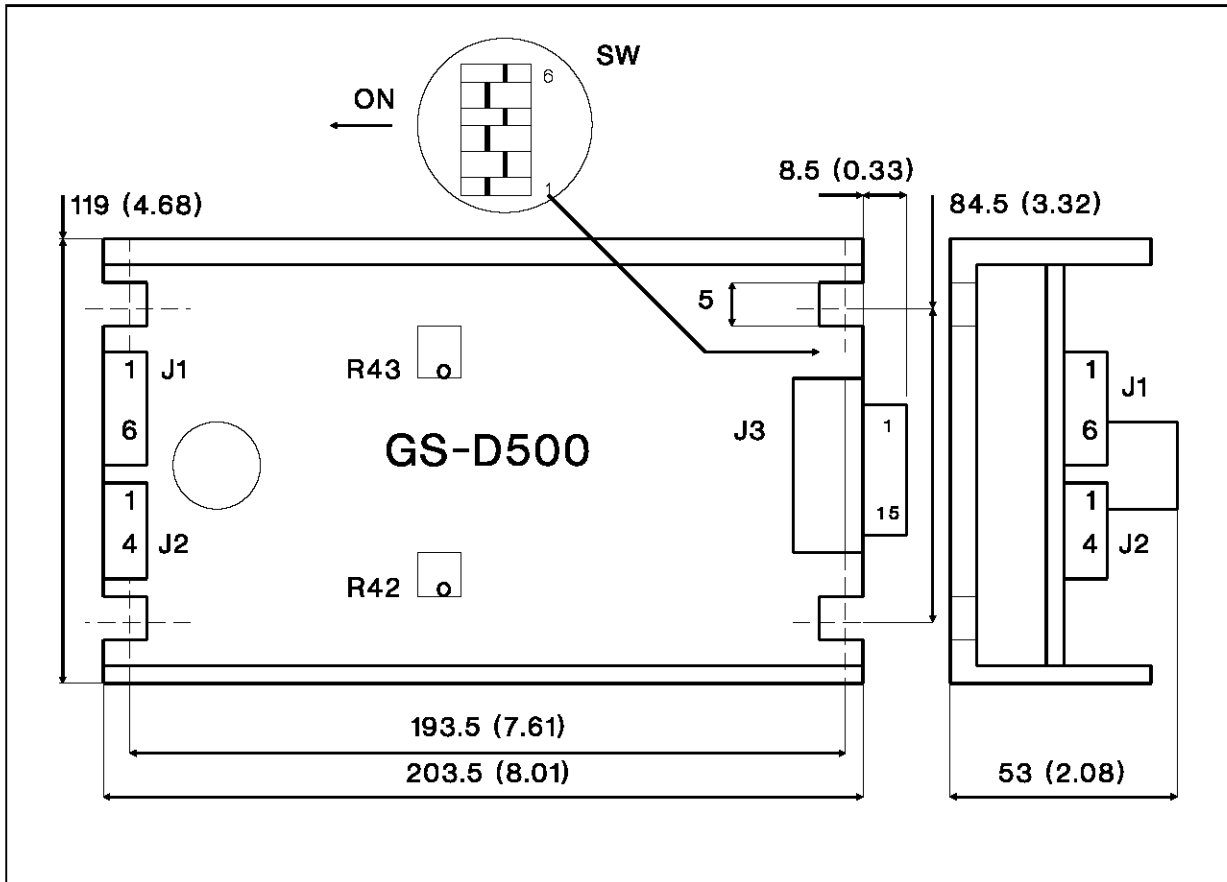

Figure 2. Block diagram



GS-D500A

MECHANICAL DATA (dimensions are in millimeters)



GS-D500A HARDWARE AVAILABLE COMMANDS

SW1, SW2, SW3	Microsteps/step programming
SW4	Phase peak current selection
SW5	Midrange stabilization ON/OFF
SW6	Current reduction at rest
R42	Phase AB current programming
R43	Phase CD current programming

GS-D500A CONNECTORS PINS DESCRIPTION

CONNECTOR J1

J1-1	Phase A output
J1-2	Phase B output
J1-3	Phase C output
J1-4	Phase D output
J1-6	Ground

CONNECTOR J2

J2-1	Motor Supply Voltage
J2-3	Auxiliary Supply Voltage (+12V)
J2-2,4	Ground

CONNECTOR J3

Pin	Function
J3-1	Step clock isolated input (see fig. 3): this is a logic input that performs the step function, i.e. on every transition of this input the motor is moved one step in the proper direction.
J3-2	Direction isolated input (see fig. 4): the logic state applied to this pin decides the rotation direction of the motor shaft.

J3-4	Microsteps/step rate remote programming (SW1).
J3-5	On board +5V output
J3-6,7	Return path for on board +5V output
J3-8	Disable input (see fig. 6): a logic high level applied to this input causes the power driver outputs to float. This condition allows the manual positioning of the system. Care must be used when this input is activated because the detention torque is lost.
J3-9	Optocoupler supply voltage
J3-10	Zero current control isolated input (see fig. 5): when activated the phase current is reduced to zero
J3-12	Microsteps/step rate remote programming (SW2)
J3-13	Fault logic output (see fig. 9): this output is at a low logic level whenever an anomalous condition is detected.
J3-15	Microsteps/step rate remote programming (SW3)

Figure 3. Stepclock input circuit

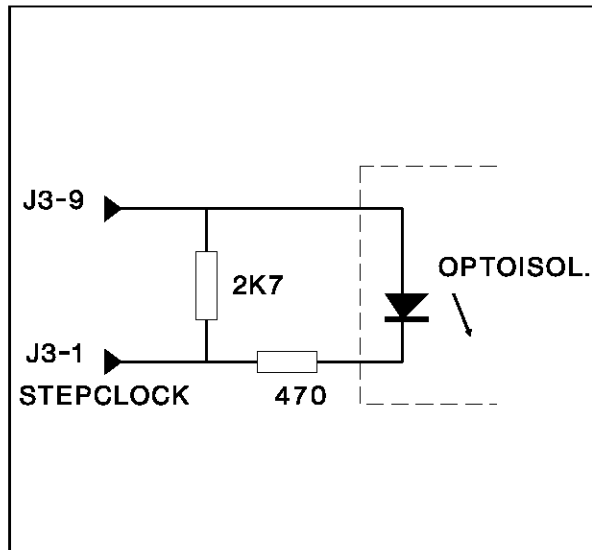

Figure 4. Direction input circuit

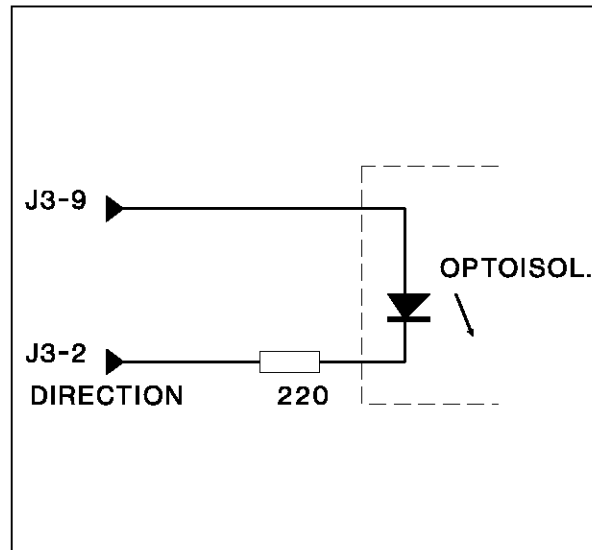

Figure 5. Zero current input circuit

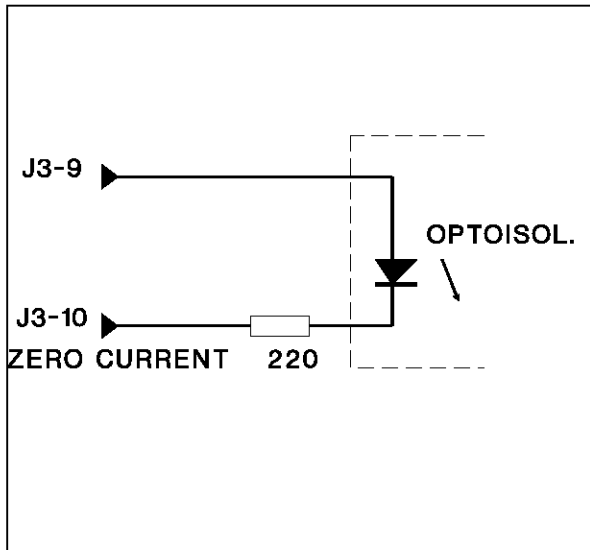
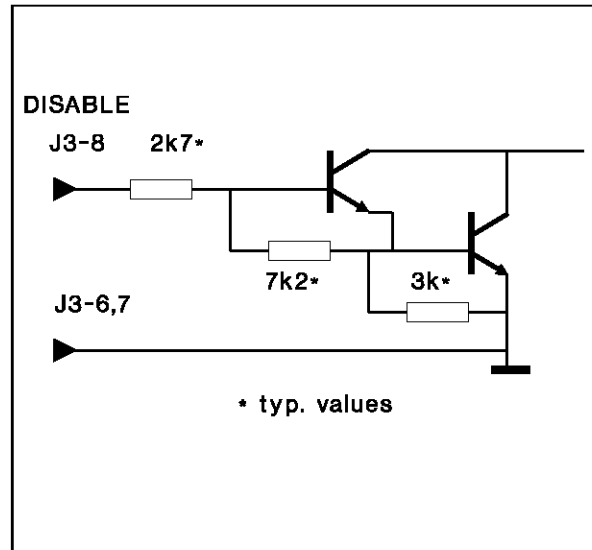

Figure 6. Disable input circuit



A - GS-D500A DESCRIPTION

The **GS-D500A** is a complete subsystem to drive stepper motors either in full step or microstep mode. A very large number of auxiliary functions has been included to allow extreme simplicity and flexibility in use.

Particular care has been devoted to protections, so that the **GS-D500A** can be safely used in very harsh environments.

In addition to the obvious function to drive the motor phases in a chopping mode, the following functions have been implemented:

- Sine/cosine generation
- Selection of three different microsteps/step rates
- Selection of full/half step drive
- Programming of peak phase current to optimize the torque

- Automatic phase current reduction at rest (selectable)
- Full protection against short-circuit between phase-to-phase and phase-to-ground
- Thermal and undervoltage protection
- Galvanic isolation of 3 input signals (**clock, direction, zero current**).
- Fault indication output
- On board auxiliary voltages generation
- Midrange stability circuitry (selectable)

As a result, the **GS-D500A** can provide up to 5A per phase and, in its simplest application, just three command signals are required: **step clock, direction, disable**.

A1 - SUPPLY VOLTAGE

THE POWER SUPPLY MUST BE TURNED OFF WHEN PLUGGING OR UNPLUGGING THE BOARD

The supply pins are:

J2-1 for Motor Supply Voltage

J2-3 for Auxiliary Voltage

J2-2,4 for Ground rail

The other supply voltages needed by the boards are internally generated.

If an undervoltage condition is detected ($V_s < 10V$) the GS-D500A is automatically disabled and a led is activated.

The Motor Supply voltage is in the range from 12 to 100V, the Auxiliary voltage from 11 to 13V.

At power-on the Auxiliary Supply voltage must be applied before the Motor Supply voltage, while at power-off the Motor Supply voltage must be removed before the Auxiliary voltage.

A2 - FULL-STEP/HALF-STEP/MICROSTEP PROGRAMMING BY HARDWARE

The number of microsteps per step is field programmable. The digitized sine and cosine functions, required by a microstepping control, are stored in a Lock-Up-Table inside the GS-D500A.

Two options are provided for the proper microsteps/step rate selection.

Three switches (SW1, SW2, SW3) are available on the front edge of the board.

The full-step/half-step/microstep mode is defined by the following table.

SW1	SW2	SW3	MODE
OFF	ON	OFF	Half step
ON	ON	OFF	125 microsteps/step
ON	OFF	ON	25 microsteps/step
OFF	ON	ON	5 microsteps/step
ON	ON	ON	Full step

The switches are in OFF condition when the knob is pulled versus the board edge. Invalid combinations disable the board.

A2.1 - MICROSTEP PROGRAMMING BY HOST COMPUTER

The microsteps/step rate can also be remotely changed by using the three logic inputs available on the J3 connector (pins 4,12 and 15) that corresponds, respectively, to SW1, SW2, SW3.

The interaction between logic signals and hardware switches is shown in fig. 4.

Figure 7. Remote microstepping programming

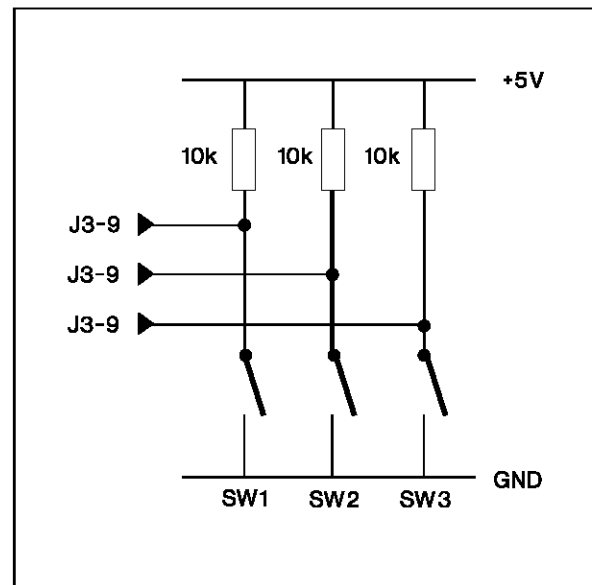

To operate the logic pins of the J3 connector, the three internal switches must be in the OFF state.

A3 - CURRENT REDUCTION AT REST

Phase current can be reduced when the motor is stopped if SW6 is open.

Current reduction is operative about 1 second after the last clock pulse.

A4 - SETTING OF THE DIRECTION POLARITY

The rotation direction signal must be applied at pin J3-3.

The direction (CW or CCW) depends on the status of the direction signal as shown in the following table:

DIR. SIGNAL	ROTATION
HIGH	CCW
LOW	CW

A5 - PHASE CURRENT PROGRAMMING

The phase current can be programmed by means two on-board trimmer called R42 and R43 (see mechanical drawing).

R42 programs the current in phase AB, while R43 programs the current in phase CD.

A6 - MIDRANGE STABILITY

A particular circuitry is implemented on the board to avoid midrange oscillations.

This circuit is inserted on the current control loop when SW5 is OFF.

A7 - CURRENT SELECTION IN MICROSTEP/CONSTANT CURRENT SWITCHING (SW4)

When the board is used to drive a motor in microstep mode, an automatic switching from sinusoidal current to constant current is performed when the sinusoidal output waveform exceeds 500Hz. The constant output current can be chosen to be 0.707 of the peak current or the peak current: this possibility is given by SW4. (See fig. 8).

SW4 OFF	0.707 x I _{peak}
SW4 ON	I _{peak}

An histeresys is inserted on the 500Hz threshold to avoid unwanted oscillations.

Figure 8. Current selection by SW4

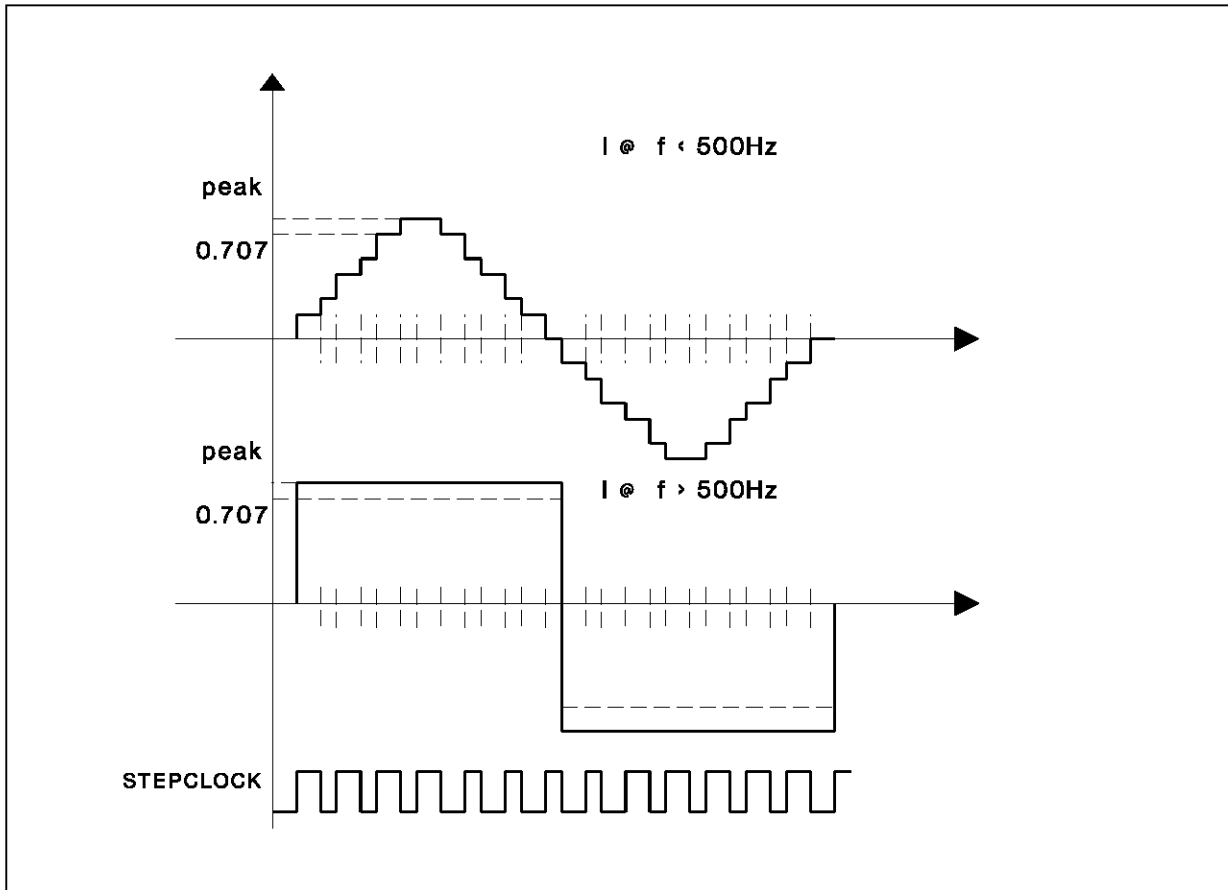

A8 - OUTPUT OVERLOAD AND SHORT CIRCUIT PROTECTION

To prevent permanent damage to the GS-D500A, three protections have been implemented against overload and short circuits between:

- output to output
- output to ground

When one of these adverse conditions occurs, the driver of the output H-bridges is disabled for about 500ms and the condition is signaled by the FAULT signal.

A9 - FAULT SIGNAL

The FAULT signal is available at pin J3-13. When a fault is present, pin 13 goes low versus pins 6,7.

Whenever the FAULT signal is activated, the led provided in the front edge of the module is switched ON.

The FAULT signal is active (low) when:

- the supply voltage is lower than 12V
- the heatsink temperature is higher than 90°C
- an output overload is present
- a disable is active.

Figure 9 - FAULT signal output circuit

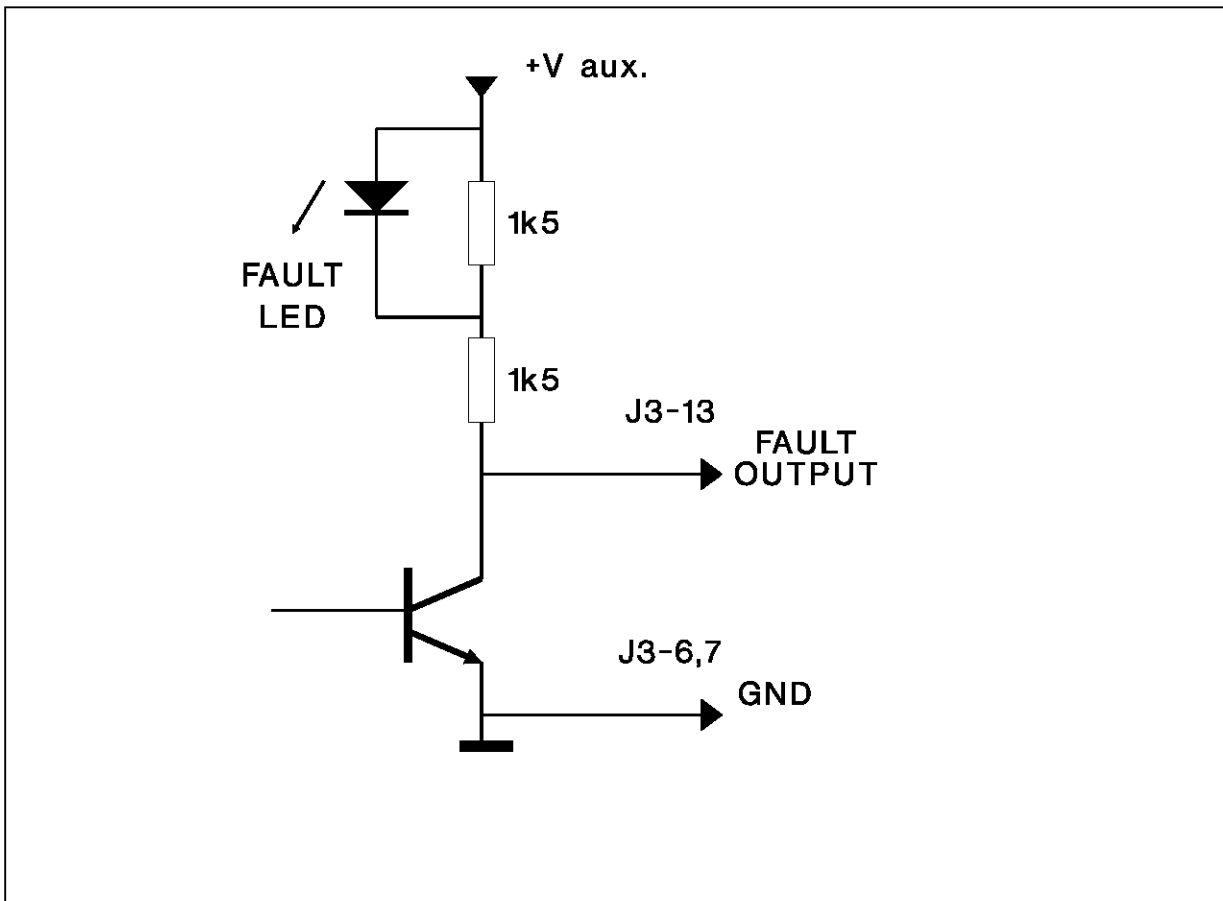

Information furnished is believed to be accurate and reliable. However, SGS-THOMSON Microelectronics assumes no responsibility for the consequences of use of such information nor for any infringement of patents or other rights of third parties which may result from its use. No license is granted by implication or otherwise under any patent or patent rights of SGS-THOMSON Microelectronics. Specification mentioned in this publication are subject to change without notice. This publication supersedes and replaces all information previously supplied. SGS-THOMSON Microelectronics products are not authorized for use as critical components in life support devices or systems without express written approval of SGS-THOMSON Microelectronics.

© 1994 SGS-THOMSON Microelectronics – All Rights Reserved

SGS-THOMSON Microelectronics GROUP OF COMPANIES

Australia - Brazil - China - France - Germany - Hong Kong - Italy - Japan - Korea - Malaysia - Malta - Morocco - The Netherlands -
Singapore - Spain - Sweden - Switzerland - Taiwan - Thailand - United Kingdom - U.S.A.