

Single 16-Ch/Differential 8-Ch CMOS Analog Multiplexers

Features

- Low On-Resistance: 240 Ω
- TTL and CMOS Logic Compatible
- Low Power: 30 mW
- Break-Before-Make Switching
- 44-V Power Supply Rating
- Transition Time: 600 ns

Benefits

- Easily Interfaced
- Low Power Consumption
- Low System Crosstalk
- Wide Analog Signal Range

Applications

- Communication Systems
- ATE
- Data Acquisition Systems
- Audio Signal Routing and Multiplexing
- Medical Instrumentation

Description

The DG506A, a 16-channel single-ended analog multiplexer, is designed to connect one of sixteen inputs to a common output as determined by a 4-bit binary address (A_0, A_1, A_2, A_3). The DG507A, a differential 8-channel analog multiplexer, is designed to connect one of eight differential inputs to a common differential outputs as determined by its 3-bit binary address (A_0, A_1, A_2) logic. Break-before-make switching action protects against momentary shorting of the input signals.

peak-to-peak. An enable (EN) function allows for device selection when several multiplexers are used. All control inputs, address (A_X) and enable (EN) are TTL or CMOS compatible over the full specified operating temperature range.

The DG506A/507A are fabricated in the Siliconix PLUS-40 process, which includes improved ESD protection for ruggedness. An epitaxial layer prevents latch up.

A channel in the on state conducts current equally well in both directions. In the off state each channel blocks voltages up to the power supply rails, normally 30 V

For wideband/video multiplexing, the DG536 is recommended.

Functional Block Diagrams and Pin Configurations

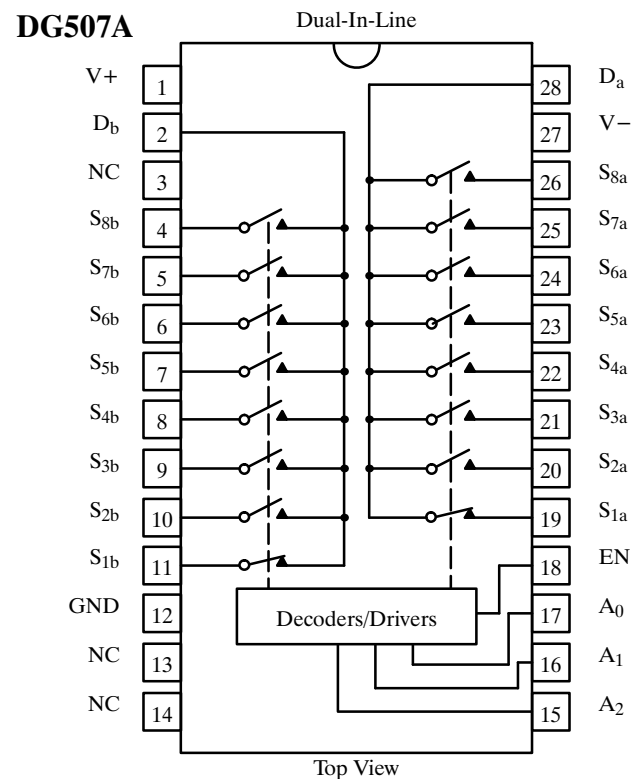
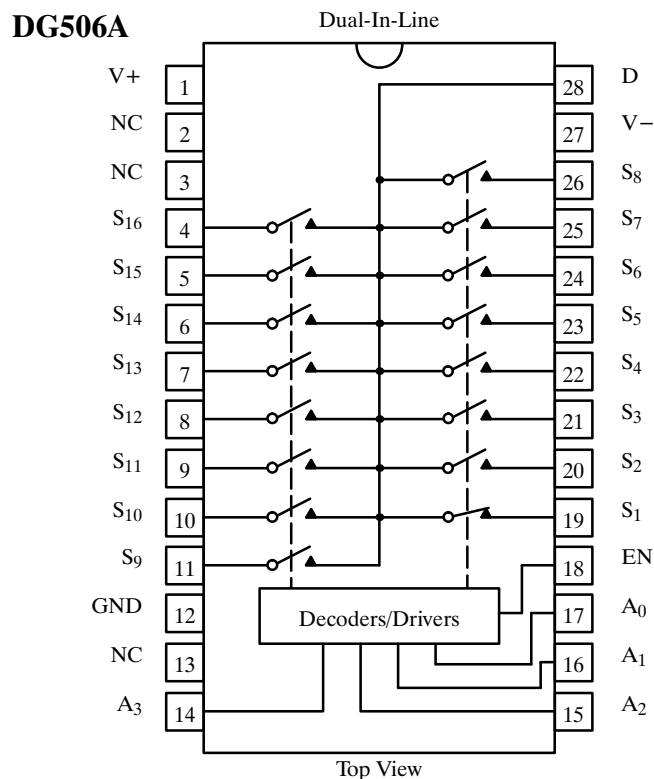

DG506A/507A

Functional Block Diagrams and Pin Configurations

Truth Table — DG506A

A ₃	A ₂	A ₁	A ₀	EN	On Switch
X	X	X	X	0	None
0	0	0	0	1	1
0	0	0	1	1	2
0	0	1	0	1	3
0	0	1	1	1	4
0	1	0	0	1	5
0	1	0	1	1	6
0	1	1	0	1	7
0	1	1	1	1	8
1	0	0	0	1	9
1	0	0	1	1	10
1	0	1	0	1	11
1	0	1	1	1	12
1	1	0	0	1	13
1	1	0	1	1	14
1	1	1	0	1	15
1	1	1	1	1	16

Truth Table — DG507A

A ₂	A ₁	A ₀	EN	On Switch
X	X	X	0	None
0	0	0	1	1
0	0	1	1	2
0	1	0	1	3
0	1	1	1	4
1	0	0	1	5
1	0	1	1	6
1	1	0	1	7
1	1	1	1	8

Logic "0" = V_{AL} ≤ 0.8 V
 Logic "1" = V_{AH} ≥ 2.4 V
 X = Don't Care

Ordering Information — DG506A

Temp Range	Package	Part Number
0 to 70°C	28-Pin Plastic DIP	DG506ACJ
	28-Pin CerDIP	DG506ACK
		DG506ABK
-25 to 85°C		
-40 to 85°C	28-Pin PLCC	DG506ADN
-55 to 125°C	28-Pin CerDIP	DG506AAK
		DG506AAK/883
	28-Pin Sidebrazed	JM38510/19001BXC
	LCC-20*	DG506AAZ/883

Ordering Information — DG507A

Temp Range	Package	Part Number
0 to 70°C	28-Pin Plastic DIP	DG507ACJ
-55 to 125°C	28-Pin CerDIP	DG507AAK
		DG507AAK/883
	28-Pin Sidebrazed	JM38510/19003BXC
	28-Pin LCC	DG507AAZ/883

*Block Diagram and Pin Configuration not shown.

Absolute Maximum Ratings

Voltage Referenced to V-

V+ 44 V

GND 25 V

Digital Inputs^a, V_S, V_D (V-) -2 V to (V+) +2 V or 20 mA, whichever occurs first

Current (Any Terminal, Except S or D) 30 mA

Continuous Current, S or D 20 mA

Peak Current, S or D (Pulsed at 1 ms, 10% Duty Cycle Max) 40 mA

Storage Temperature (CerDIP) -65 to 150°C
 (Plastic DIP) -65 to 125°C

Power Dissipation (Package)^b

28-Pin Plastic DIP^c 625 mW

28-Pin CerDIP and Sidebrazed 1200 mW

28-Pin PLCC^c 1200 mW

LCC-20,28^d 1000 mW

Notes:

- Signals on S_X, D_X or IN_X exceeding V+ or V- will be clamped by internal diodes. Limit forward diode current to maximum current ratings.
- All leads soldered or welded to PC board.
- Derate 8.3 mW/°C above 75°C.
- Derate 14 mW/°C above 75°C.

Specifications^a

Parameter	Symbol	Test Conditions Unless Otherwise Specified $V_+ = 15\text{ V}, V_- = -15\text{ V}$ $V_{IN} = 2.4\text{ V}, 0.8\text{ V}^f$		Temp ^b	Typ ^c	A Suffix -55 to 125°C		B, C, D Suffix 0 to 70°C -25 to 85°C -40 to 85°C		Unit
						Min ^d	Max ^d	Min ^d	Max ^d	
Analog Switch										
Analog Signal Range ^e	V_{ANALOG}			Full		-15	15	-15	15	V
Drain-Source On-Resistance	$r_{DS(on)}$	$V_D = \pm 10\text{ V}, I_S = -200\ \mu\text{A}$		Room Full	240		400 500		450 550	Ω
$r_{DS(on)}$ Matching ^g	$\Delta r_{DS(on)}$	$-10\text{ V} < V_S < 10\text{ V}$		Room	6					%
Source Off Leakage Current	$I_{S(off)}$	$V_S = \pm 10\text{ V}, V_D = \mp 10\text{ V}$ $V_{EN} = 0\text{ V}$		Room Full		-1 -50	1 50	-5 -50	5 50	nA
Drain Off Leakage Current	$I_{D(off)}$	$V_D = \mp 10\text{ V}$ $V_S = \pm 10\text{ V}$ $V_{EN} = 0\text{ V}$	DG506A	Room Full		-10 -300	10 300	-20 -300	20 300	
			DG507A	Room Full		-5 -200	5 200	-10 -200	10 200	
Drain On Leakage Current	$I_{D(on)}$	$V_S = V_D = \pm 10\text{ V}$	DG506A	Room Full		-10 -300	10 300	-20 -300	20 300	
			DG507A	Room Full		-5 -200	5 200	-10 -200	10 200	
Digital Control										
Logic Input Current Input Voltage High	I_{AH}	$V_A = 2.4\text{ V}$		Room Full		-10 -30		-10 -30		μA
		$V_A = 15\text{ V}$		Room Full			10 30		10 30	
Logic Input Current Input Voltage Low	I_{AL}	$V_{EN} = 0\text{ V}, 2.4\text{ V}, V_A = 0\text{ V}$		Room Full		-10 -30		-10 -30		
Dynamic Characteristics										
Transition Time	t_{TRANS}	See Figure 2		Room	0.6		1			μs
Break-Before-Make Time	t_{OPEN}	See Figure 4		Room	0.2					
Enable Turn-On Time	$t_{ON(EN)}$	See Figure 3		Room	1					
Enable Turn-Off Time	$t_{OFF(EN)}$			Room	0.4					
Charge Injection	Q			Room	6					pC
Off Isolation ^h	OIRR	$V_{EN} = 0\text{ V}, R_L = 1\text{ k}\Omega, C_L = 15\text{ pF}$ $V_S = 7\text{ V}_{RMS}, f = 500\text{ kHz}$		Room	68					dB
Source Off Capacitance	$C_{S(off)}$	$V_{EN} = 0\text{ V}, V_S = 0\text{ V}, f = 140\text{ kHz}$		Room	6					pF
Drain Off Capacitance	$C_{D(off)}$	$V_{EN} = 0\text{ V}$ $V_D = 0\text{ V}$ $f = 140\text{ kHz}$	DG506A	Room	45					
			DG507A	Room	23					
Power Supplies										
Positive Supply Current	I_+	$V_{EN} = 0\text{ V}, V_A = 0\text{ V}$		Room	1.3		2.4		2.4	mA
Negative Supply Current	I_-			Room	-0.7	-1.5		-1.5		

Notes:

- Refer to PROCESS OPTION FLOWCHART (Section 5 of the 1994 Data Book or FaxBack number 7103).
- Room = 25°C, Full = as determined by the operating temperature suffix.
- Typical values are for DESIGN AID ONLY, not guaranteed nor subject to production testing.
- The algebraic convention whereby the most negative value is a minimum and the most positive a maximum, is used in this data sheet.
- Guaranteed by design, not subject to production test.
- V_{IN} = input voltage to perform proper function.

$$g. \Delta r_{DS(on)} = \left(\frac{r_{DS(on)MAX} - r_{DS(on)MIN}}{r_{DS(on)AVE}} \right)$$

- Off isolation = $20 \log \frac{V_D}{V_S}$, V_S = input to off switch, V_D = output due to V_S .

Typical Characteristics

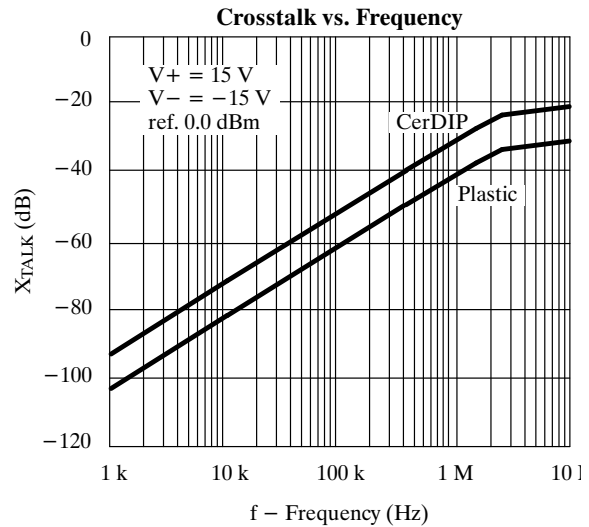
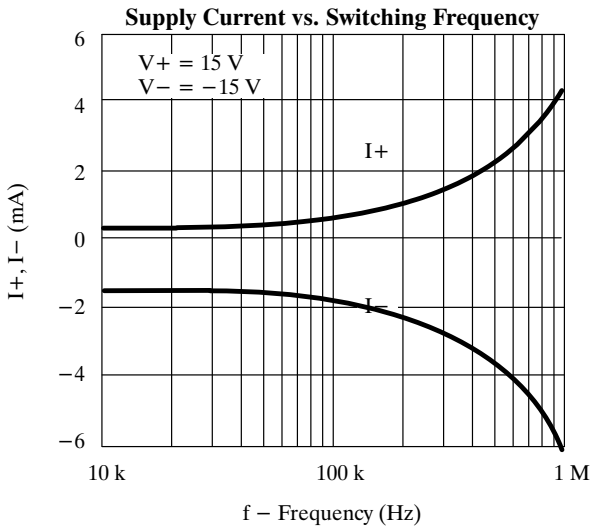
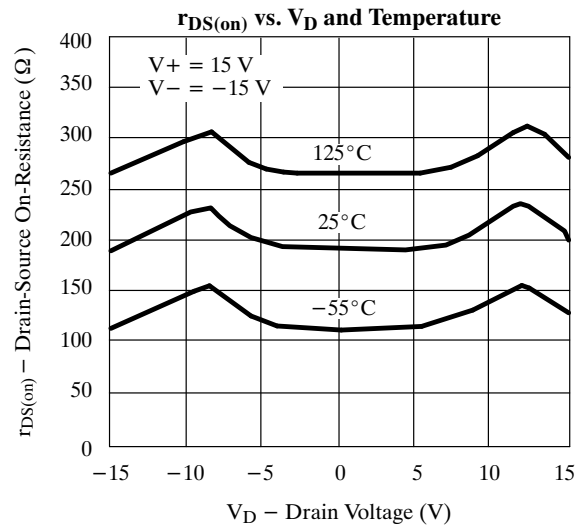
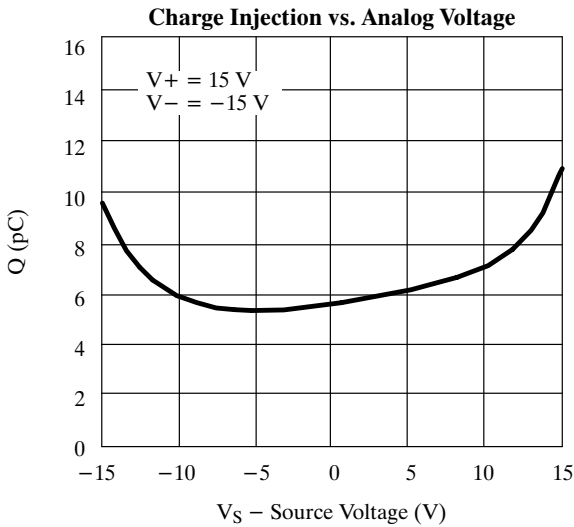
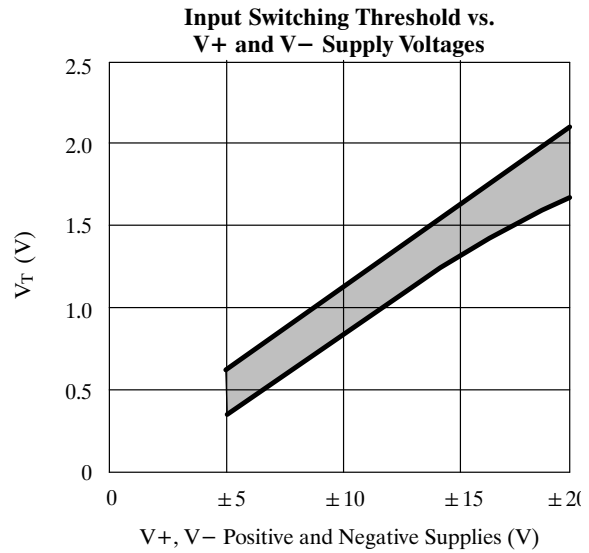
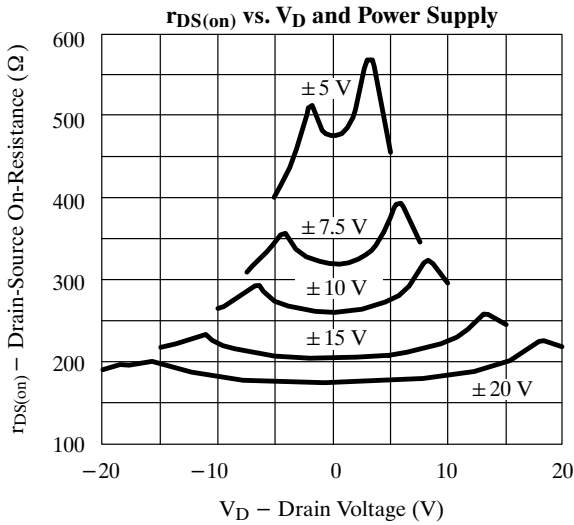

Typical Characteristics (Cont'd)

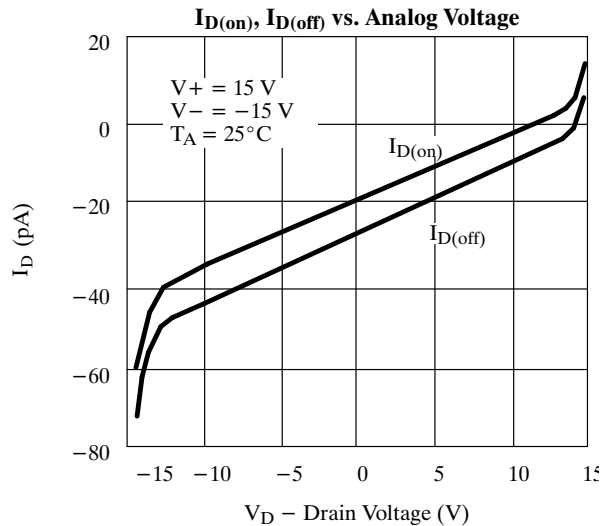
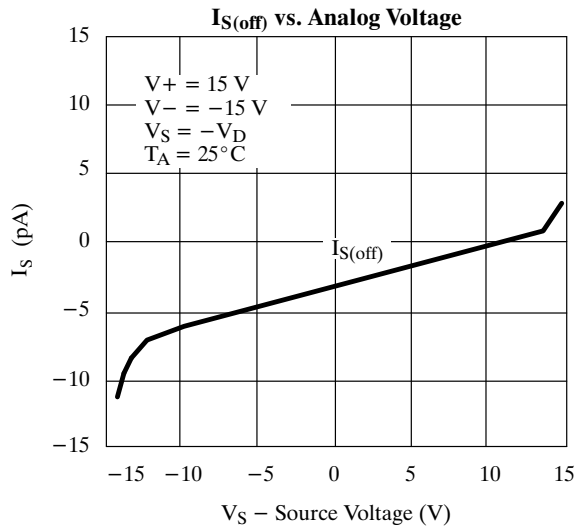
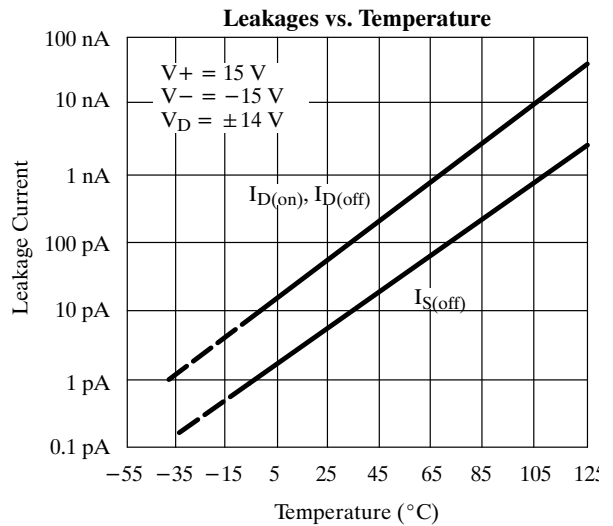
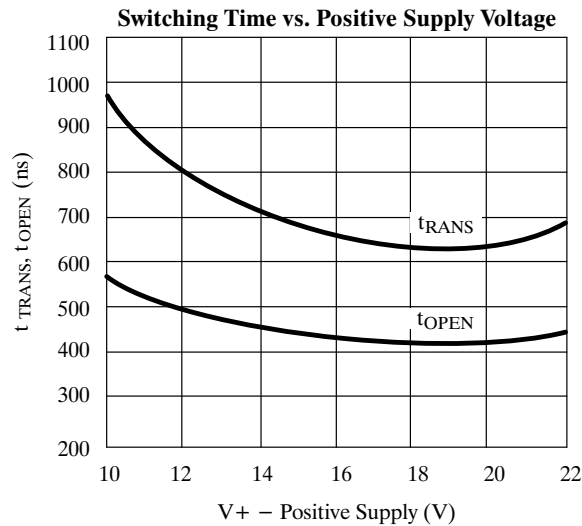
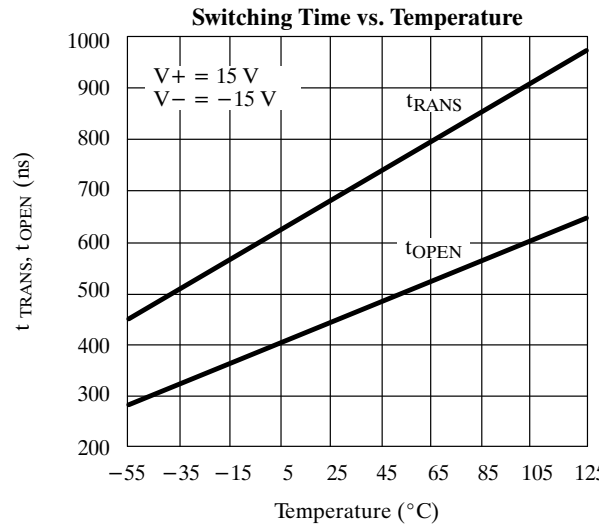
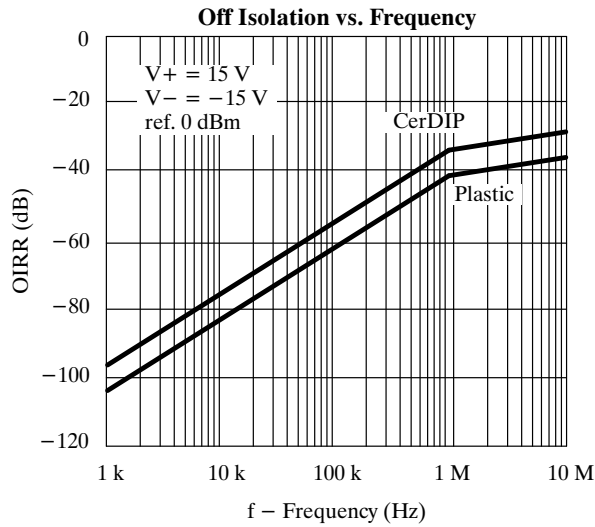

DG506A/507A

Schematic Diagram (Typical Channel)

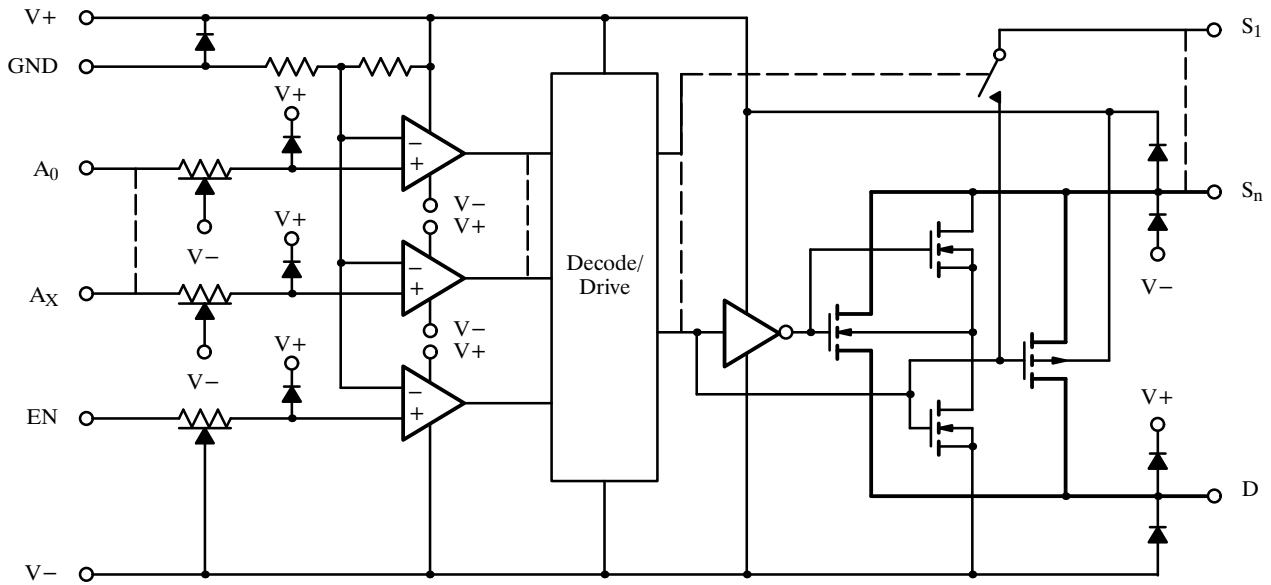
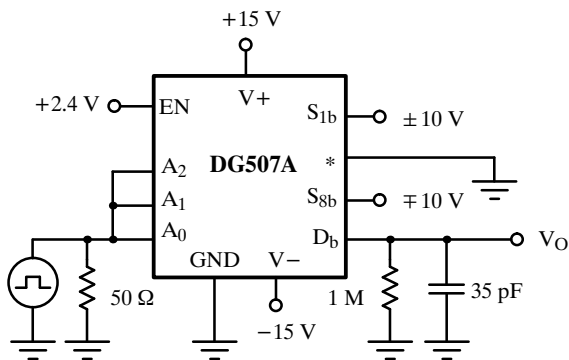
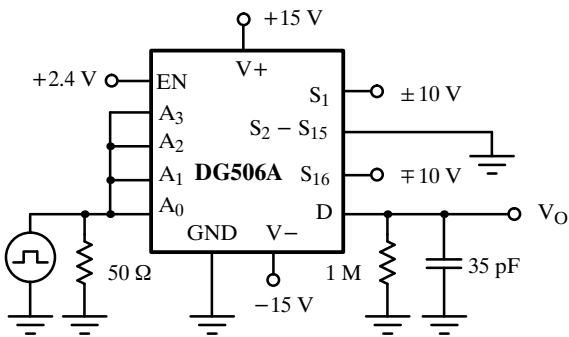

Figure 1.

Test Circuits



* = S_{1a} - S_{8a}, S_{2b} - S_{7b}, D_a

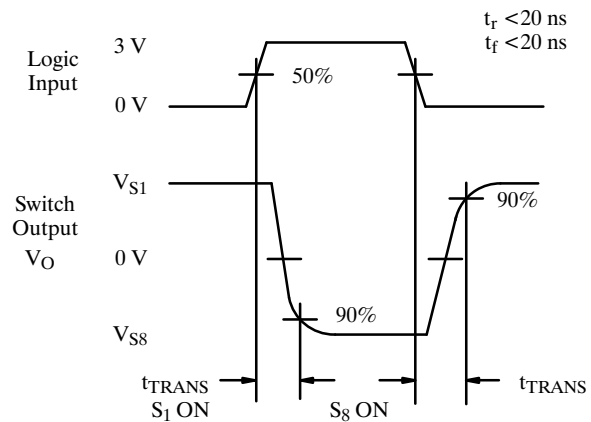

Figure 2. Transition Time

Test Circuits (Cont'd)

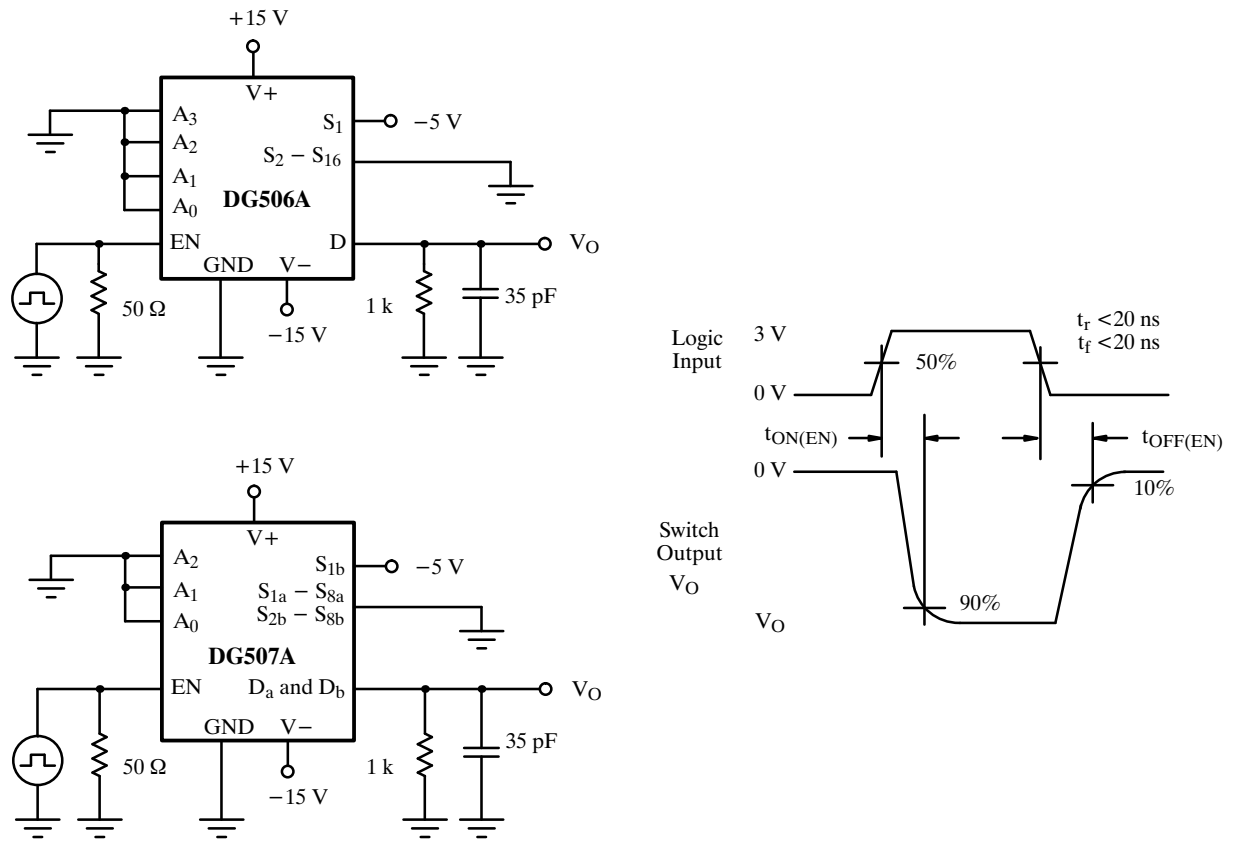

Figure 3. Enable Switching Time

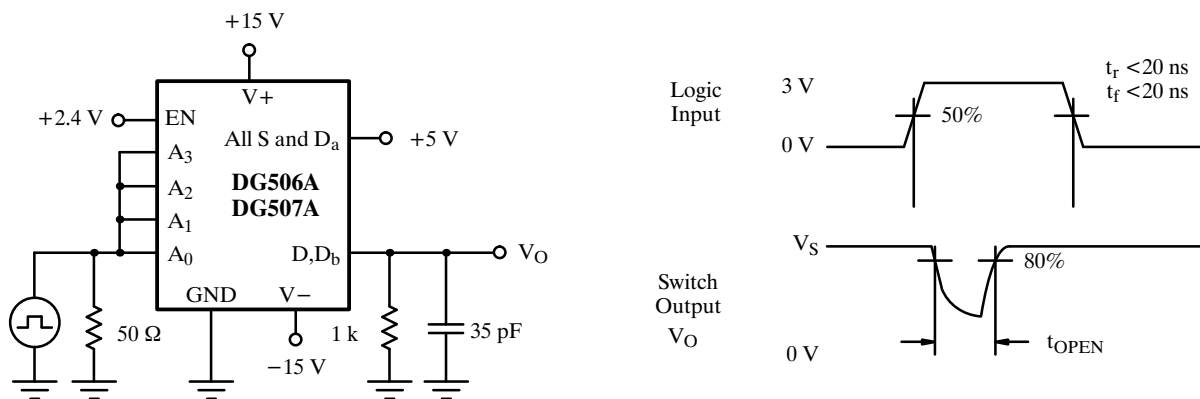

Figure 4. Break-Before-Make Interval

DG506A/507A

Application Hints^a

V+ Positive Supply Voltage (V)	V- Negative Supply Voltage (V)	V _{IN} Logic Input Voltage V _{INH(min)} /V _{INL(max)} (V)	V _S or V _D Analog Voltage Range (V)
15 ^b	-15	2.4/0.8	-15 to 15
12	-12	2.4/0.8	-12 to 12
10	-10	2.2/0.6	-10 to 10
8 ^c	-8	2.0/0.5	-8 to 8

Notes:

- Application Hints are for DESIGN AID ONLY, not guaranteed and not subject to production testing.
- Electrical Parameter Chart based on V+ = 15 V, V- = -15 V.
- Operation below ±8 V is not recommended due to shift in V_{INL(MAX)}.

Applications

Overvoltage Protection

A very convenient form of overvoltage protection consists of adding two small signal diodes (1N4148, 1N914 type) in series with the supply pins (see Figure 5). This arrangement effectively blocks the flow of reverse currents. It also floats the supply pin above or below the normal V+ or V- value. In this case the overvoltage signal actually becomes the power supply of the IC. From the point of view of the chip, nothing has changed, as long as the difference between V_S and the V- rail doesn't exceed +44 V. The addition of these diodes will reduce the analog signal range to 1 V below V+ and 1 V above V-, but it preserves the low channel resistance and low leakage characteristics.

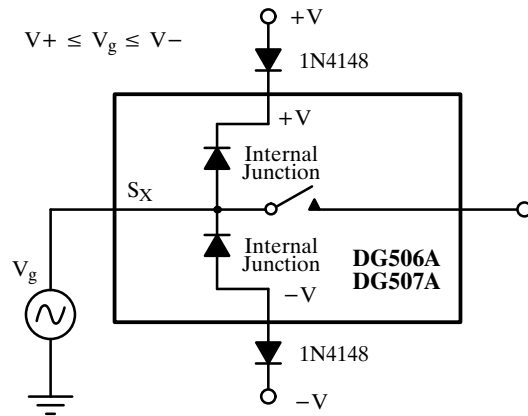

Figure 5. Overvoltage Protection Using Blocking Diodes

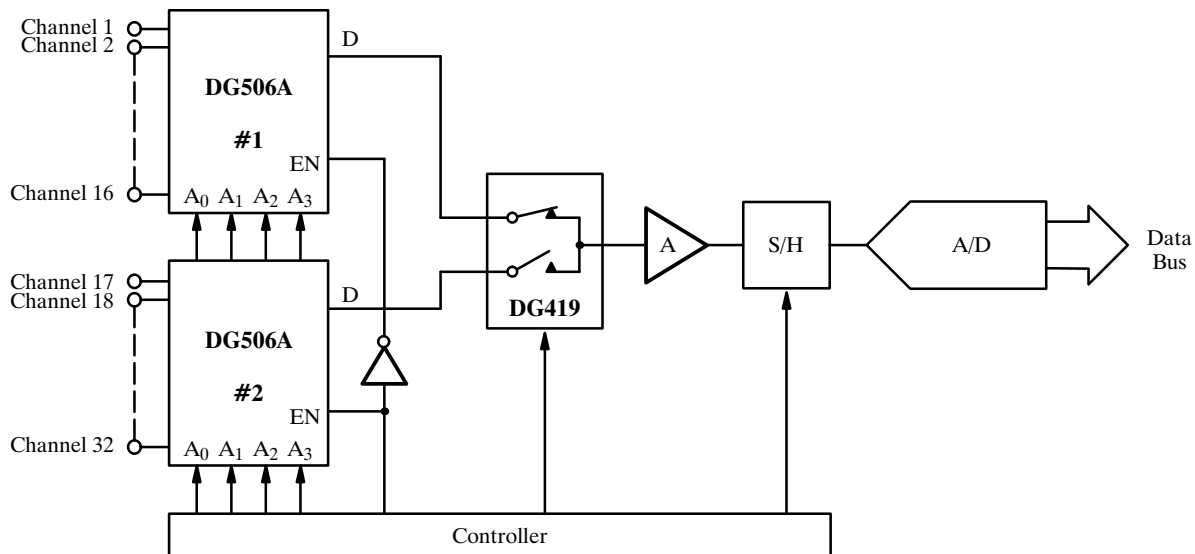

Figure 6. A 32-Channel Data Acquisition System