

Precision CMOS Analog Switches

Features

- $\pm 15\text{-V}$ Analog Signal Range
- On-Resistance— $r_{DS(on)}$: $20\ \Omega$
- Fast Switching Action— t_{ON} : $100\ \text{ns}$
- Ultra Low Power Requirements— P_D : $35\ \text{nW}$
- TTL and CMOS Compatible
- MiniDIP and SOIC Packaging
- 44-V Supply Max Rating

Benefits

- Wide Dynamic Range
- Low Signal Errors and Distortion
- Break-Before-Make Switching Action
- Simple Interfacing
- Reduced Board Space
- Improved Reliability

Applications

- Precision Test Equipment
- Precision Instrumentation
- Battery Powered Systems
- Sample-and-Hold Circuits
- Military Radios
- Guidance and Control Systems
- Hard Disk Drives

Description

The DG417/418/419 monolithic CMOS analog switches were designed to provide high performance switching of analog signals. Combining low power, low leakages, high speed, low on-resistance and small physical size, the DG417 series is ideally suited for portable and battery powered industrial and military applications requiring high performance and efficient use of board space.

To achieve high-voltage ratings and superior switching performance, the DG417 series is built on Siliconix's

high voltage silicon gate (HVSG) process. Break-before-make is guaranteed for the DG419, which is an SPDT configuration. An epitaxial layer prevents latchup.

Each switch conducts equally well in both directions when on, and blocks up to the power supply level when off.

The DG417 and DG418 respond to opposite control logic levels as shown in the Truth Table.

Functional Block Diagram and Pin Configuration

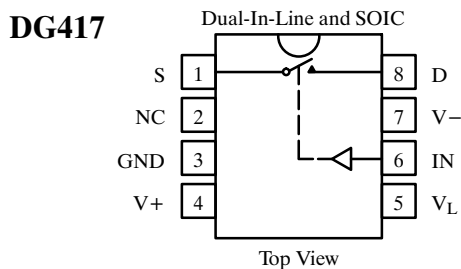

Truth Table — DG417/418

Logic	DG417	DG418
0	ON	OFF
1	OFF	ON

Logic "0" = $\leq 0.8\ \text{V}$, Logic "1" = $\geq 2.4\ \text{V}$
Switch Shown for DG417 Logic "1" Input

Ordering Information — DG417/418

Temp Range	Package	Part Number
-40 to 85°C	8-Pin Plastic MiniDIP	DG417DJ
		DG418DJ
	8-Pin Narrow SOIC	DG417DY
		DG418DY
-55 to 125°C	8-Pin CerDIP	DG417AK, DG417AK/883
		DG418AK, DG418AK/883

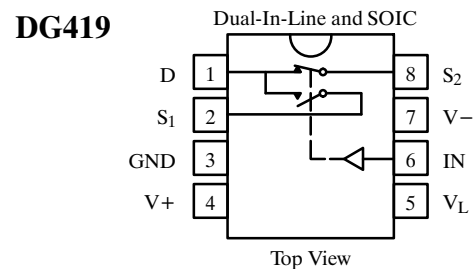

Truth Table — DG419

Logic	SW ₁	SW ₂
0	ON	OFF
1	OFF	ON

Logic "0" = $\leq 0.8\ \text{V}$, Logic "1" = $\geq 2.4\ \text{V}$
Switches Shown for DG419 Logic "1" Input

Ordering Information — DG419

Temp Range	Package	Part Number
-40 to 85°C	8-Pin Plastic MiniDIP	DG419DJ
	8-Pin Narrow SOIC	DG419DY
-55 to 125°C	8-Pin CerDIP	DG419AK, DG419AK/883

DG417/418/419

Absolute Maximum Ratings

Voltages Referenced to V-

V+	44 V
GND	25 V
V _L	(GND - 0.3 V) to (V+) + 0.3 V
Digital Inputs ^a V _S , V _D	(V-) - 2 V to (V+) + 2 V or 30 mA, whichever occurs first

Current, (Any Terminal) Continuous	30 mA
Current (S or D) Pulsed 1 ms, 10% duty cycle	100 mA
Storage Temperature (AK Suffix)	-65 to 150°C
(DJ, DY Suffix)	-65 to 125°C

Power Dissipation (Package)^b

8-Pin Plastic MiniDIP ^c	400 mW
8-Pin Narrow SOIC ^d	400 mW
8-Pin CerDIP ^e	600 mW

Notes:

- Signals on S_X, D_X, or IN_X exceeding V+ or V- will be clamped by internal diodes. Limit forward diode current to maximum current ratings.
- All leads welded or soldered to PC Board.
- Derate 6 mW/°C above 75°C
- Derate 6.5 mW/°C above 25°C
- Derate 12 mW/°C above 75°C

Specifications^a

Parameter	Symbol	Test Conditions Unless Otherwise Specified V+ = 15 V, V- = -15 V V _L = 5 V, V _{IN} = 2.4 V, 0.8 V ^f	Temp ^b	Typ ^c	A Suffix -55 to 125°C		D Suffix -40 to 85°C		Unit
					Min ^d	Max ^d	Min ^d	Max ^d	
Analog Switch									
Analog Signal Range ^e	V _{ANALOG}		Full		-15	15	-15	15	V
Drain-Source On-Resistance	r _{DS(on)}	I _S = -10 mA, V _D = ±12.5 V V+ = 13.5 V, V- = -13.5 V	Room Full	20		35 45		35 45	Ω
Switch Off Leakage Current	I _{S(off)}	V+ = 16.5 V, V- = -16.5 V V _D = ±15.5 V V _S = ±15.5 V	Room Full	-0.1	-0.25 -20	0.25 20	-0.25 -5	0.25 5	nA
			DG417 DG418	Room Full	-0.1	-0.25 -20	0.25 20	-0.25 -5	
	DG419		Room Full	-0.1	-0.75 -60	0.75 60	-0.75 -12	0.75 12	
Channel On Leakage Current	I _{D(on)}	V+ = 16.5 V, V- = -16.5 V V _S = V _D = ±15.5 V	DG417 DG418	Room Full	-0.4	-0.4 -40	0.4 40	-0.4 -10	0.4 10
			DG419	Room Full	-0.4	-0.75 -60	0.75 60	-0.75 -12	0.75 12
Digital Control									
Input Current V _{IN} Low	I _{IL}		Full	0.005	-0.5	0.5	-0.5	0.5	μA
Input Current V _{IN} High	I _{IH}		Full	0.005	-0.5	0.5	-0.5	0.5	
Dynamic Characteristics									
Turn-On Time	t _{ON}	R _L = 300 Ω, C _L = 35 pF V _S = ±10 V	DG417 DG418	Room Full	100		175 250		ns
Turn-Off Time	t _{OFF}	See Switching Time Test Circuit	DG417 DG418	Room Full	60		145 210	145 210	
Transition Time	t _{TRANS}	R _L = 300 Ω, C _L = 35 pF V _{S1} = ±10 V, V _{S2} = ∓10 V	DG419	Room Full			175 250	175 250	
Break-Before-Make Time Delay	t _D	R _L = 300 Ω, C _L = 35 pF V _{S1} = V _{S2} = ±10 V	DG419	Room	13	5		5	
Charge Injection	Q	C _L = 10 nF, V _{gen} = 0 V, R _{gen} = 0 Ω		Room	60				pC
Source Off Capacitance	C _{S(off)}	f = 1 MHz, V _S = 0 V		Room	8				pF
Drain Off Capacitance	C _{D(off)}		DG417 DG418	Room	8				

Specifications^a

Parameter	Symbol	Test Conditions Unless Otherwise Specified $V_+ = 15\text{ V}, V_- = -15\text{ V}$ $V_L = 5\text{ V}, V_{IN} = 2.4\text{ V}, 0.8\text{ V}^f$	Temp ^b	Typ ^c	A Suffix -55 to 125°C		D Suffix -40 to 85°C		Unit	
					Min ^d	Max ^d	Min ^d	Max ^d		
Dynamic Characteristi (Cont'd)										
Channel On Capacitance	$C_{D(on)}$	$f = 1\text{ MHz}, V_S = 0\text{ V}$	DG417	Room	30					pF
			DG418	Room	30					
			DG419	Room	35					
Power Supplies										
Positive Supply Current	I_+	$V_+ = 16.5\text{ V}, V_- = -16.5\text{ V}$ $V_{IN} = 0\text{ or }5\text{ V}$	Room Full	0.001		1 5		1 5	μA	
Negative Supply Current	I_-		Room Full	-0.001	-1 -5		-1 -5			
Logic Supply Current	I_L		Room Full	0.001		1 5		1 5		
Ground Current	I_{GND}		Room Full	-0.000 1	-1 -5		-1 -5			

Specifications^a for Unipolar Supplies

Parameter	Symbol	Test Conditions Unless Otherwise Specified $V_+ = 12\text{ V}, V_- = 0\text{ V}$ $V_L = 5\text{ V}, V_{IN} = 2.4\text{ V}, 0.8\text{ V}^f$	Temp ^b	Typ ^c	A Suffix -55 to 125°C		D Suffix -40 to 85°C		Unit
					Min ^d	Max ^d	Min ^d	Max ^d	
Analog Switch									
Analog Signal Range ^e	V_{ANALOG}		Full		0	12	0	12	V
Drain-Source On-Resistance	$r_{DS(on)}$	$I_S = -10\text{ mA}, V_D = 3.8\text{ V}$ $V_+ = 10.8\text{ V}$	Room	40					Ω
Dynamic Characteristics									
Turn-On Time	t_{ON}	$R_L = 300\ \Omega, C_L = 35\text{ pF}, V_S = 8\text{ V}$ See Switching Time Test Circuit	Room	110					ns
Turn-Off Time	t_{OFF}		Room	40					
Break-Before-Make Time Delay	t_D	$R_L = 300\ \Omega, C_L = 35\text{ pF}$	DG419	Room	60				
Charge Injection	Q	$C_L = 10\text{ nF}, V_{gen} = 0\text{ V}, R_{gen} = 0\ \Omega$	Room	5					pC
Power Supplies									
Positive Supply Current	I_+	$V_+ = 13.2\text{ V}, V_L = 5.25\text{ V}$ $V_{IN} = 0\text{ or }5\text{ V}$	Room	0.001					μA
Negative Supply Current	I_-		Room	-0.001					
Logic Supply Current	I_L		Room	0.001					
Ground Current	I_{GND}		Room	-0.001					

Notes:

- Refer to PROCESS OPTION FLOWCHART (Section 5 of the 1994 Data Book or FaxBack number 7103).
- Room = 25°C, Full = as determined by the operating temperature suffix.
- Typical values are for DESIGN AID ONLY, not guaranteed nor subject to production testing.
- The algebraic convention whereby the most negative value is a minimum and the most positive a maximum, is used in this data sheet.
- Guaranteed by design, not subject to production test.
- V_{IN} = input voltage to perform proper function.

DG417/418/419

Typical Characteristics

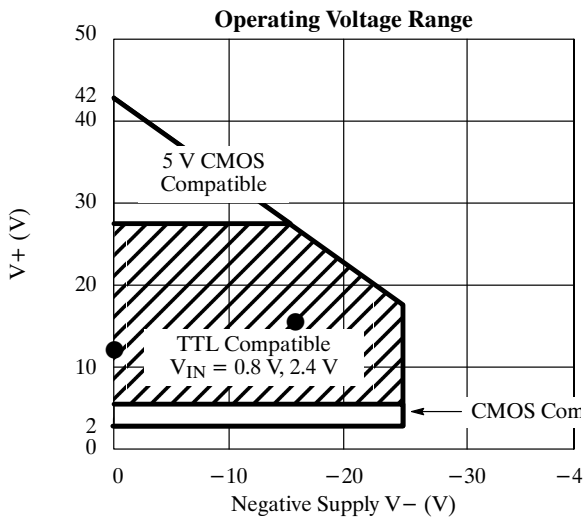
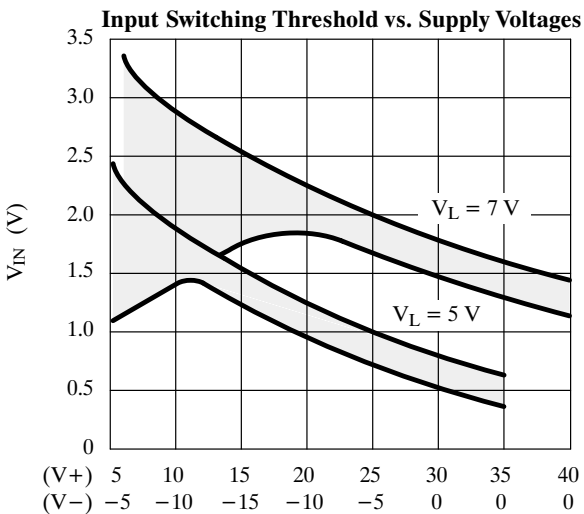
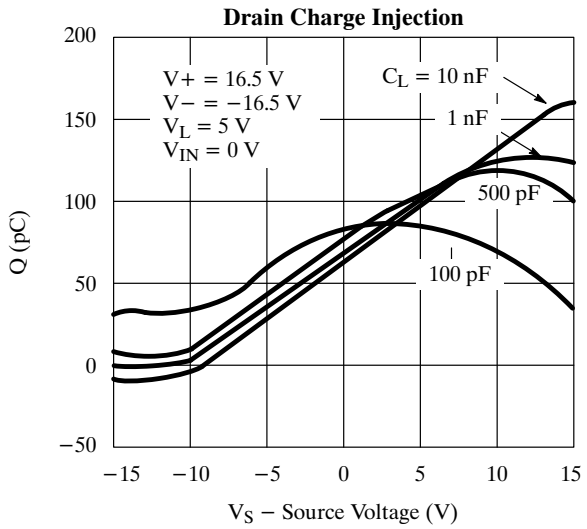
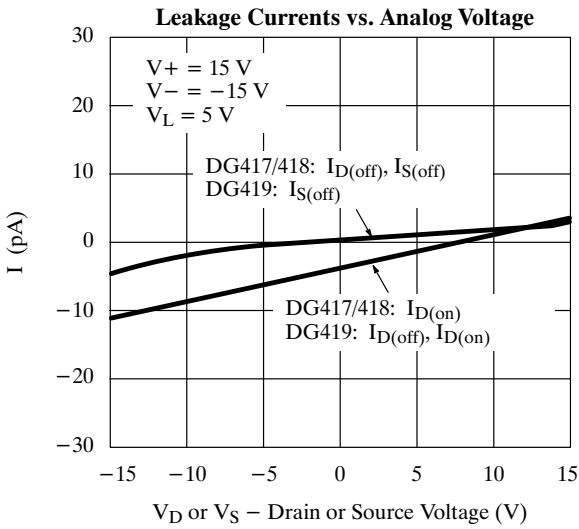
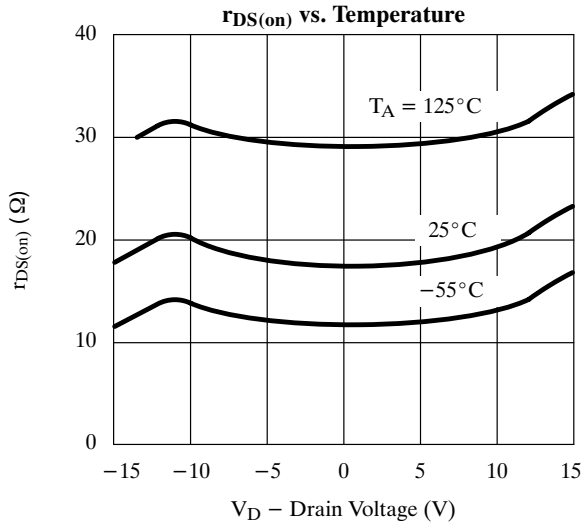
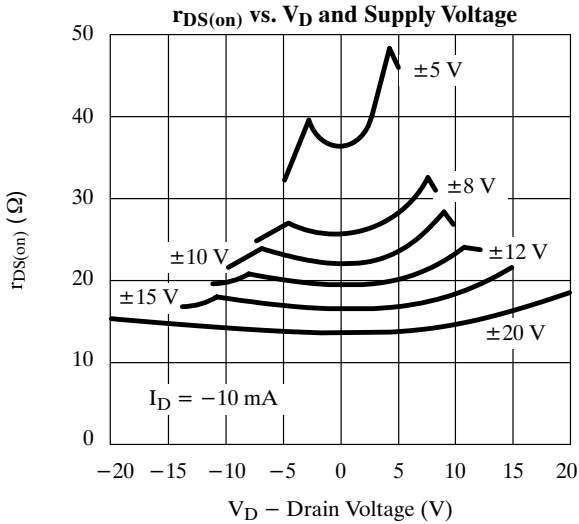

Typical Characteristics (Cont'd)

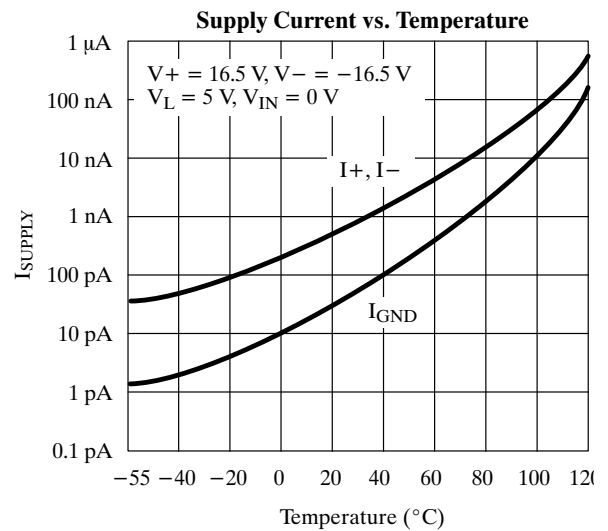
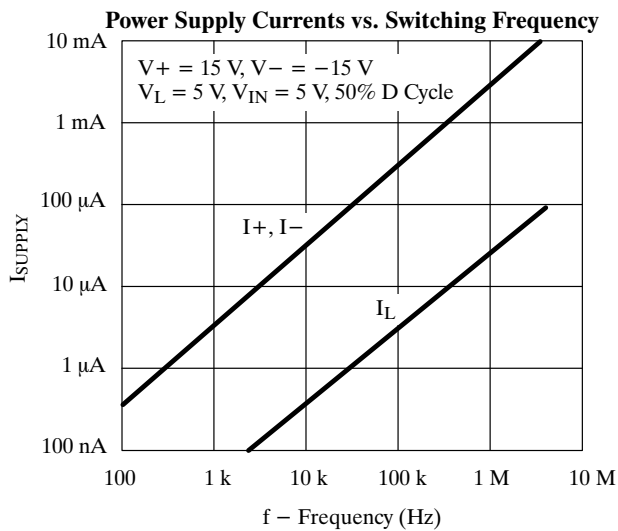
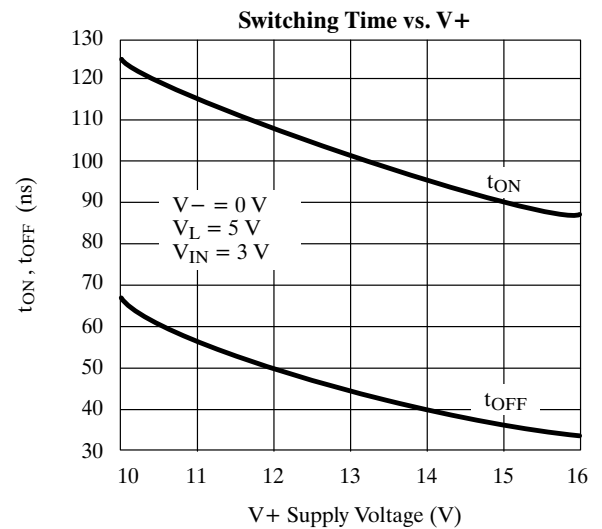
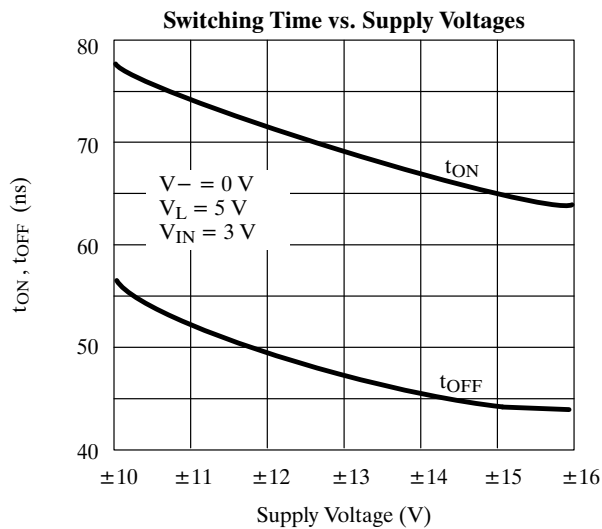
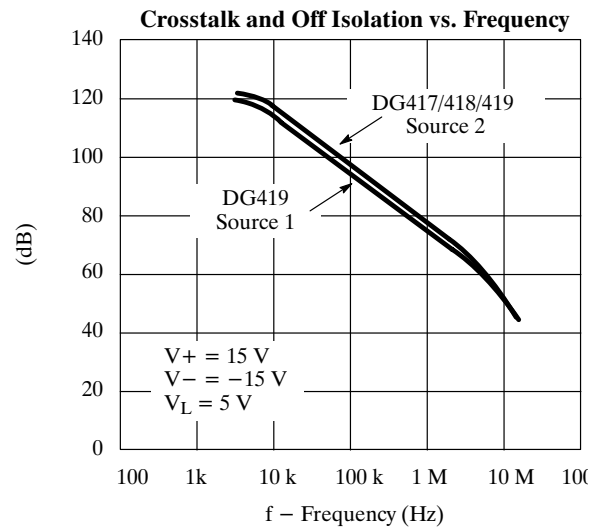
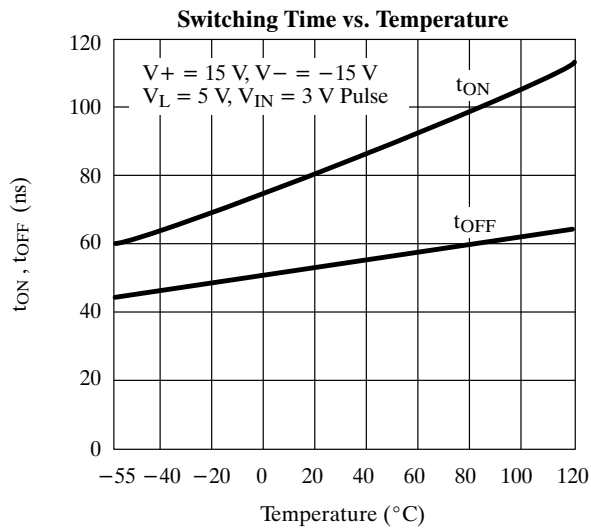

DG417/418/419

Schematic Diagram (Typical Channel)

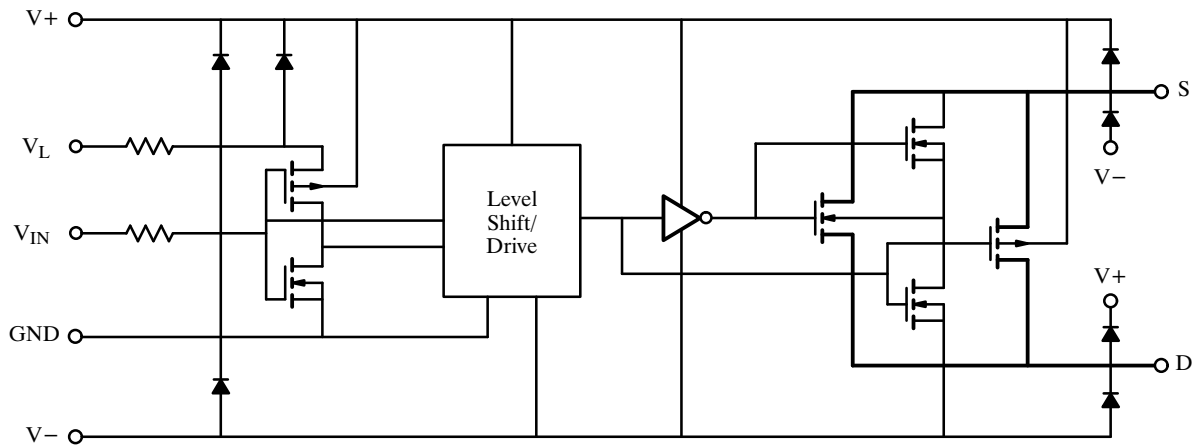
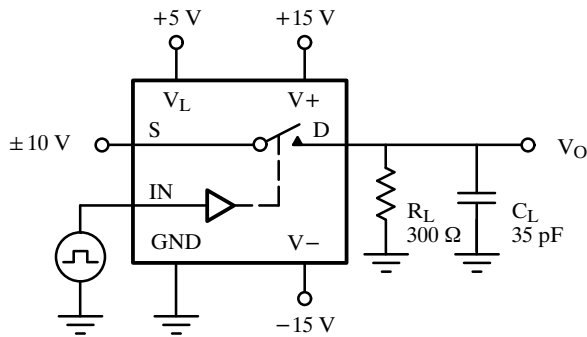

Figure 1.

Test Circuits

V_O is the steady state output with the switch on.



C_L (includes fixture and stray capacitance)

$$V_O = V_S \frac{R_L}{R_L + r_{DS(on)}}$$

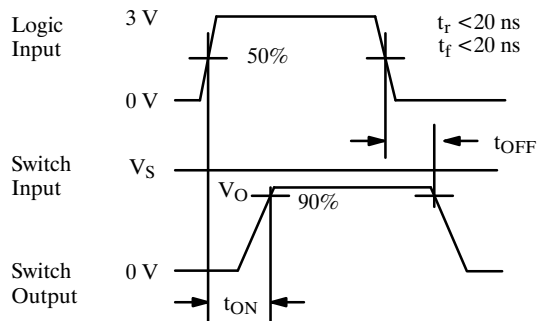

Note: Logic input waveform is inverted for switches that have the opposite logic sense.

Figure 2. Switching Time (DG417/418)

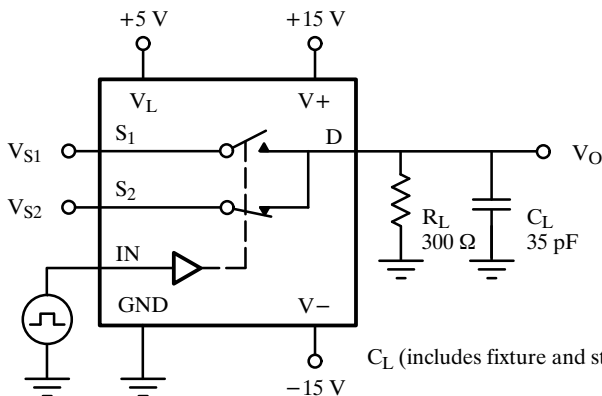

C_L (includes fixture and stray capacitance)

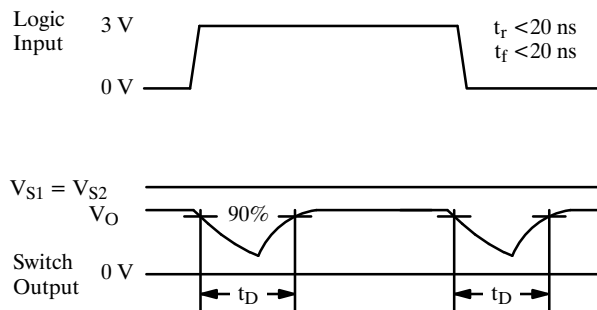
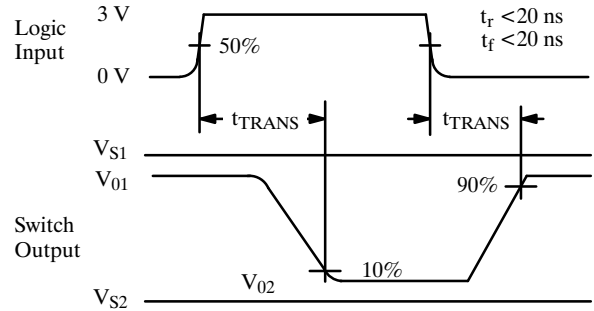
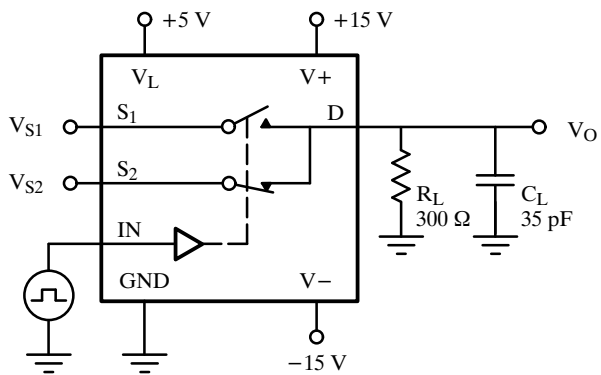

Figure 3. Break-Before-Make (DG419)

Test Circuits (Cont'd)



C_L (includes fixture and stray capacitance)

$$V_O = V_S \frac{R_L}{R_L + r_{DS(on)}}$$

Figure 4. Transition Time (DG419)

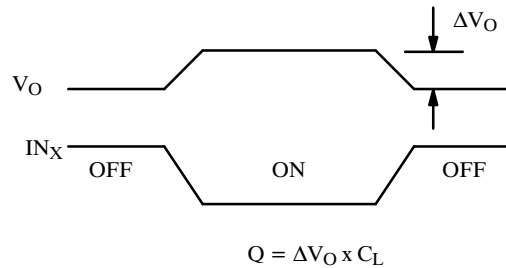
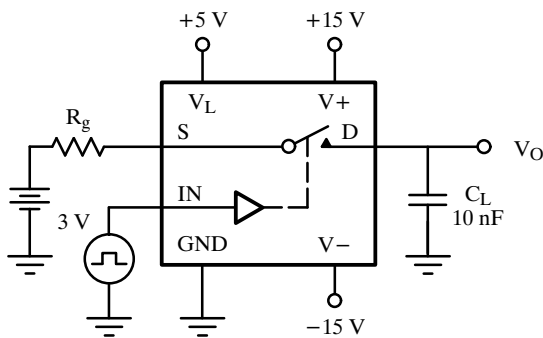
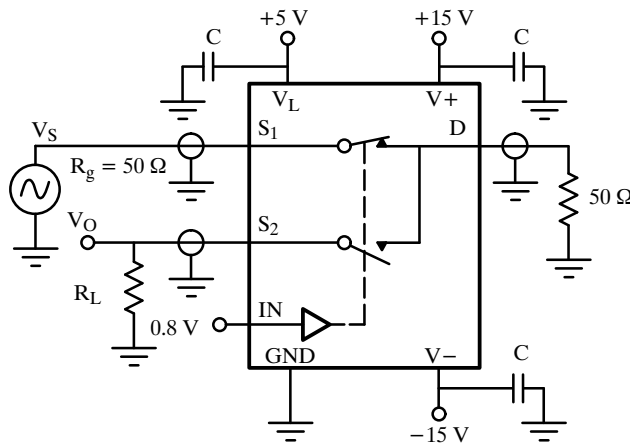

Figure 5. Charge Injection



$$X_{TALK} \text{ Isolation} = 20 \log \left| \frac{V_S}{V_O} \right|$$

$C = \text{RF bypass}$

Figure 6. Crosstalk (DG419)

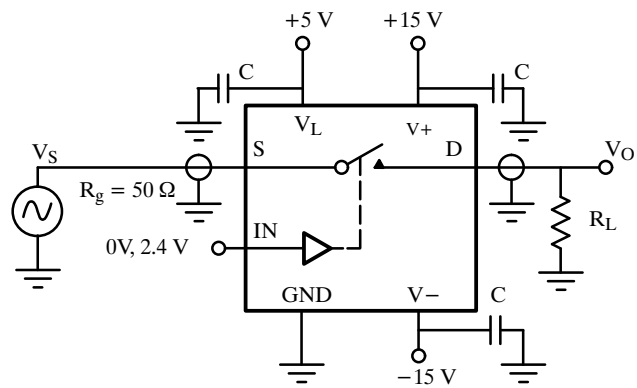

$$\text{Off Isolation} = 20 \log \left| \frac{V_S}{V_O} \right|$$

Figure 7. Off Isolation

DG417/418/419

Test Circuits (Cont'd)

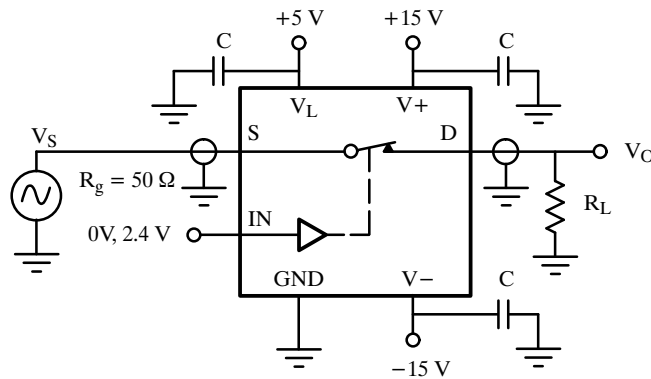

Figure 8. Insertion Loss

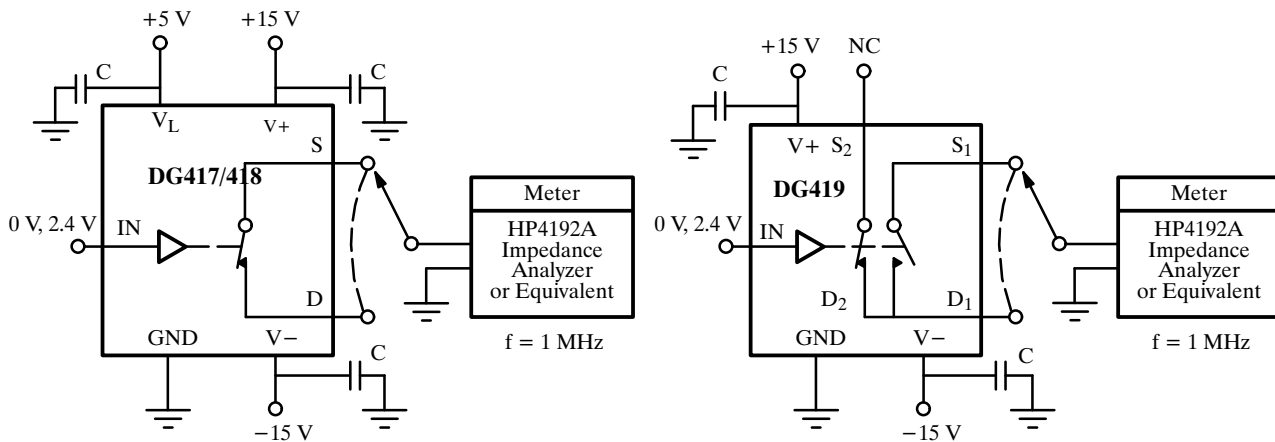

Figure 9. Source/Drain Capacitances

Applications

Switched Signal Powers Analog Switch

The analog switch in Figure 10 derives power from its input signal, provided the input signal amplitude exceeds 4 V and its frequency exceeds 1 kHz.

This circuit is useful when signals have to be routed to either of two remote loads. Only three conductors are required: one for the signal to be switched, one for the control signal and a common return.

A positive input pulse turns on the clamping diode D_1 and charges C_1 . The charge stored on C_1 is used to power the chip; operation is satisfactory because the switch requires less than 1 μ A of stand-by supply current. Loading of the signal source is imperceptible. The DG419's on-resistance is a low 100 Ω for a 5-V input signal.

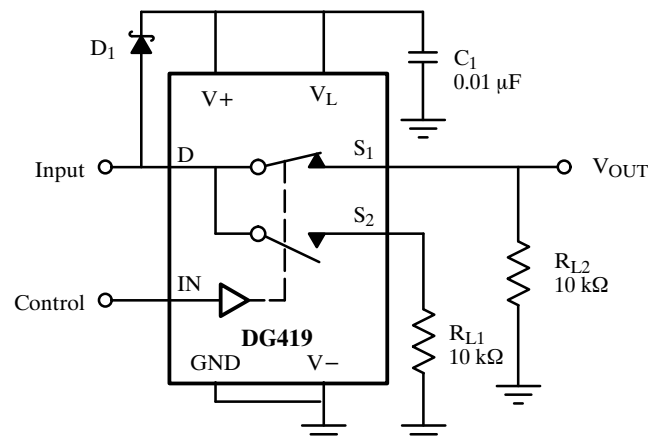

Figure 10. Switched Signal Powers Remote SPDT Analog Switch

Applications (Cont'd)

Micropower UPS Transfer Switch

When V_{CC} drops to 3.3 V, the DG417 changes states, closing SW_1 and connecting the backup cell, as shown in Figure 11. D_1 prevents current from leaking back towards the rest of the circuit. Current consumption by the CMOS analog switch is around 100 pA; this ensures that most of the power available is applied to the memory, where it is really needed. In the stand-by mode, hundreds of μA are sufficient to retain memory data.

When the 5-V supply comes back up, the resistor divider senses the presence of at least 3.5 V, and causes

a new change of state in the analog switch, restoring normal operation.

Programmable Gain Amplifier

The DG419, as shown in Figure 12, allows accurate gain selection in a small package. Switching into virtual ground reduces distortion caused by $r_{DS(on)}$ variation as a function of analog signal amplitude.

GaAs FET Driver

The DG419, as shown in Figure 13 may be used as a GaAs FET driver. It translates a TTL control signal into -8V , 0-V level outputs to drive the gate.

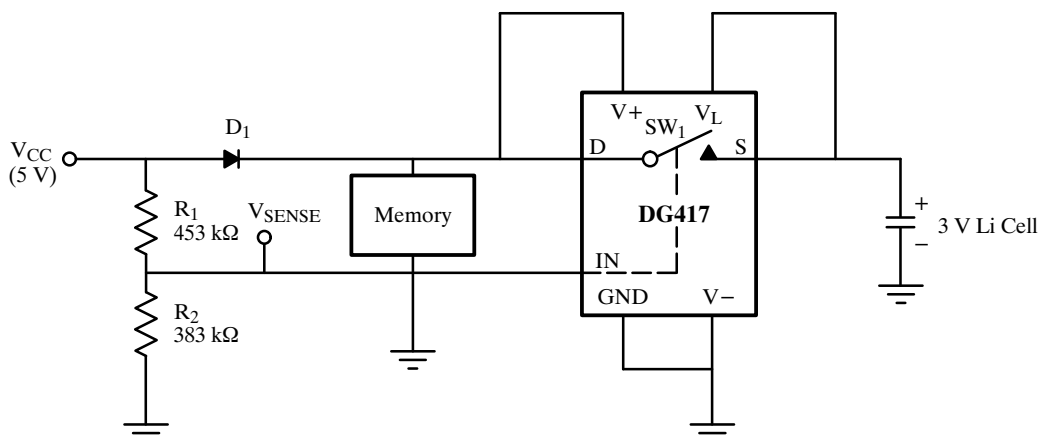

Figure 11. Micropower UPS Circuit

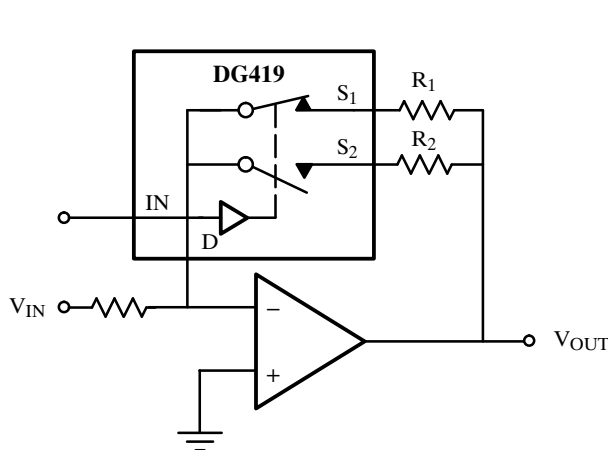

Figure 12. Programmable Gain Amplifier

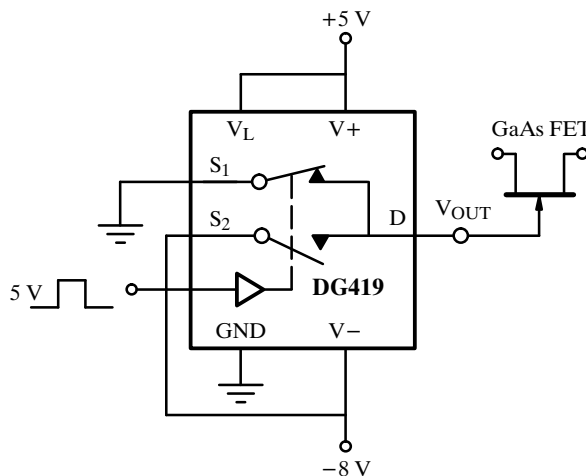

Figure 13. GaAs FET Driver