

## TEMIC Semiconductors

TEMIC is the microelectronics enterprise of Daimler-Benz. TEMIC's Semiconductor division is a leading manufacturer of application-specific, value-adding integrated circuits for communication equipment, automotive and industrial systems, computers and broadcast media. Discrete semiconductors and optoelectronic devices make the product range complete.

With a technology portfolio which includes bipolar, BiCMOS, GaAs, CMOS and DMOS processes, TEMIC Semiconductors provides a unique set of components and solutions.

## Digital Audio Broadcasting

Digital Audio Broadcasting (DAB) paves the way to the digital era of broadcasting. The DAB system was developed by the EUREKA-147 Project – a worldwide consortium of broadcasters, network operators, consumer electronic industries and research institutes.

After 10 years of research, extensive field tests are being conducted all over Europe today. In some countries, regular DAB services are about to begin; in others, DAB will be introduced within the next few years. In Germany, for example, 30 transmitters will soon transmit digitally and this number will increase with the official start of DAB in 1997.

DAB will be broadcast on terrestrial networks, but also via satellite, and users will be able to receive it using solely a tiny, non-directional stub antenna. Listeners will receive CD-like quality radio programs even in the car without any annoying interference and signal destruction. DAB complies fully with the tough requirements of the future.

DAB radio is designed for the multimedia age: DAB – with its data transmission rate of up to 1.7 million bits per second – can carry not only audio, but also text, pictures, data and even videos. Weather forecasts will be complemented by a satellite weather card of the relevant area, and the radio traffic service will be illustrated with a road map that shows traffic jams and detours. Even TV transmission with DAB is possible today. In the near future, users will be

able to read electronic newspapers, receive stock market reports and send out fax transmissions within seconds.

The DAB system features extremely sophisticated techniques, realized by state-of-the-art digital signal processing ICs. The CD-like audio quality is achieved by a special sound compression. When transmitting signals, the DAB system omits those sounds that would be imperceptible to the human ear. Thus, the amount of data is reduced to one seventh of the original signal.

In contrast to FM systems, where each program needs its own frequency, DAB combines six or more programs to a kind of 'ensemble'. The signals of this ensemble are protected against errors and spread over a wide frequency band. If some of the frequencies are disabled, the signal itself will be always be transmitted in high quality.

## Architecture of a DAB Receiver

An advanced radio transmission system such as DAB requires high-sophisticated solutions for the receiving side. The block diagram on the next page shows how this challenge can be met.

Following the signal flow from the left side of the block diagram to the right side, five major functional blocks can easily be identified:

- L band down-converter
- RF front end
- Channel decoder
- Source decoder
- Data decoder

Assuming that a DAB service will be transmitted in band 3 or L band, a signal could be received and fed into the RF front end either directly via the corresponding antenna or after processing via the L band down-converter. The mostly analog signal processing in this stage consists of selecting and filtering the desired DAB block and down-converting it to a low intermediate frequency. The next stage shown on the block diagram is the channel decoder where the demodulation channel decoding tasks of the receiver are located. Under the control of a system controller, the relevant and desired

parts of the data stream are isolated, decoded and fed into the subsequent processing stages. As an additional function for this part of the receiver, synchronization tasks are handled. The third major block is the source decoder. As DAB uses ISO/MPEG layer II (also known as MUSICAM) for the audio source decoding, a detailed description of this part can be found in ISO 11172.

In parallel with the audio decoder, an additional block can be found which allows access to different data channels. For controlling functions in the complete receiver, such as setting up the different ICs or providing an interface to the user interface, a standard microcontroller is used.

### TEMIC DAB Receiver Block Diagram

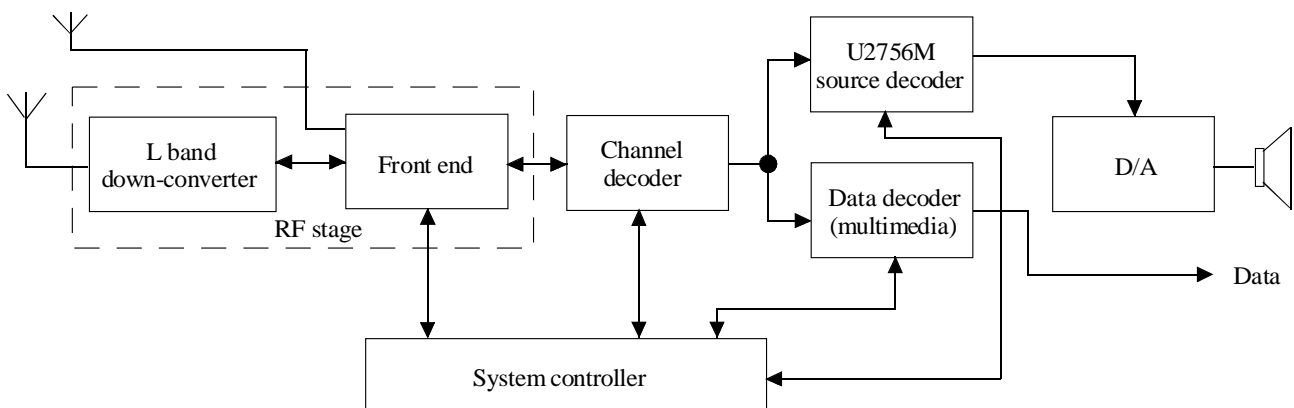

### TEMIC DAB L Band Down-Converter

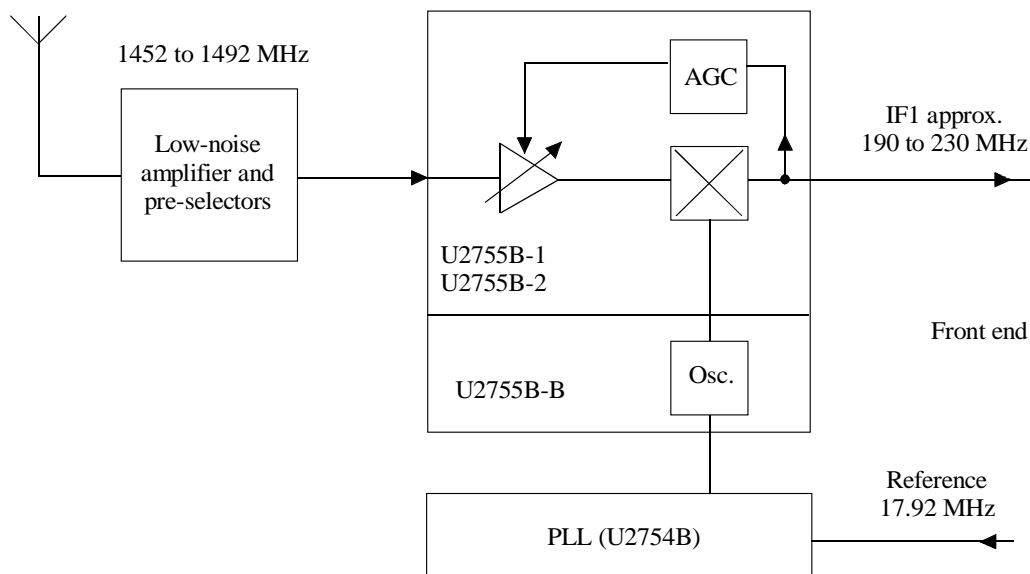

## The Radio Frequency Stage

The radio frequency (RF) front end stage processes the analog antenna signal either in band 3 or in L band and delivers an analog IF signal to the channel decoder. In order to cope with the L band, an additional down-converter, which translates a 40 MHz band (1452-1492 MHz) towards band 3, has been implemented. This L

band down- converter consists of the following main functions: input selection, mixer, local oscillator (VCO), PLL and AGC amplifier.

In the RF front end stage, the signal is amplified to a level which can be handled by an A/D converter and the channel selection is performed. The desired DAB block is chosen and the signal is transposed to a low intermediate frequency.

### TEMIC DAB RF Front End

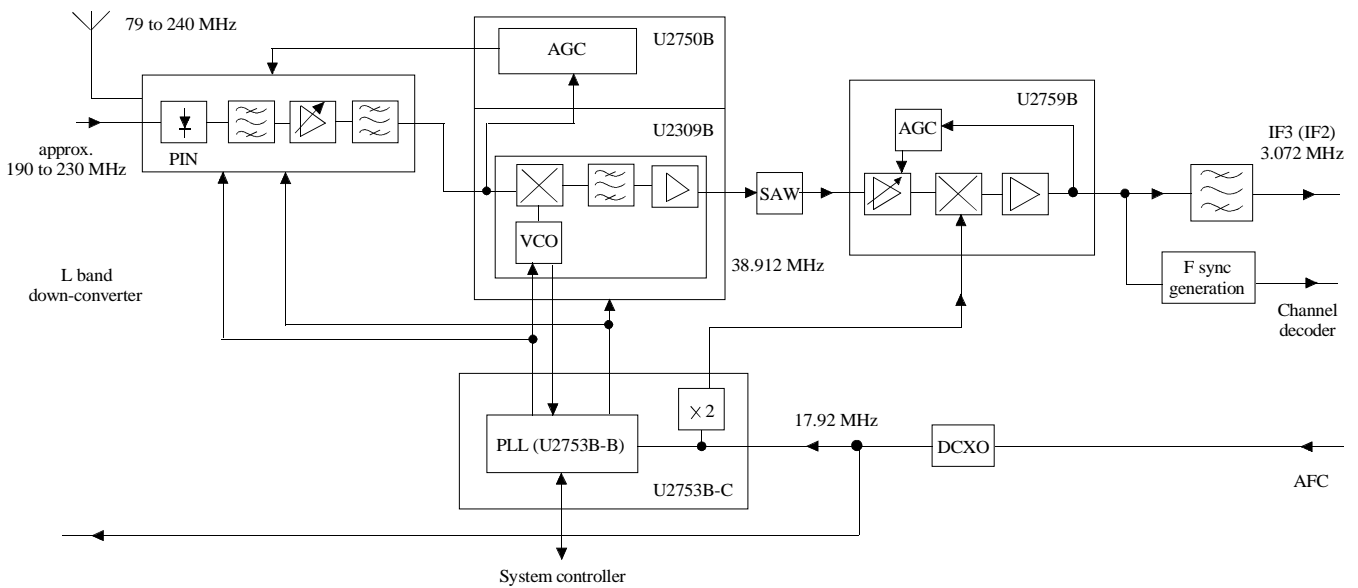

## The Channel Decoding Stage

The major part of DAB digital signal processing is concentrated in this stage which generates the bit stream data for the source- and the data decoder from the IF signal out of the RF part. The channel decoder carries out the following tasks:

- I/Q splitting of the analog IF signal
- Channel decoding of the incoming analog signal under the control of the user interface
- Synchronization of the whole receiver from a rough synchronization signal (F sync) delivered by the RF stage.

### TEMIC DAB Channel Decoder

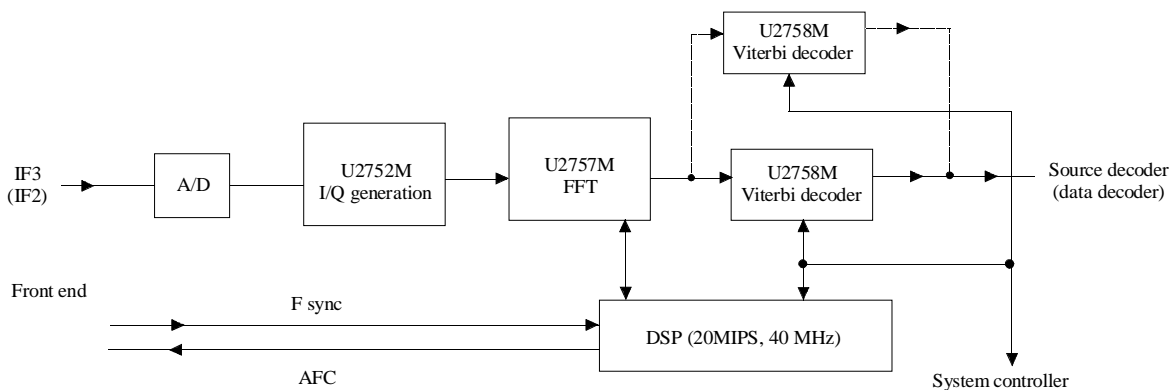

## The Source Decoding Stage

In this stage, the source compression process is reversed and the original audio bit stream is reconstructed.

## The Data Decoding Stage

The task of this block is to provide selected data at various interfaces to a PC or other data terminals. It offers access to the radio data highway in stationary or mobile receivers and thus paves the way to multimedia applications.

## TEMIC Products for DAB Receivers

Part Number	Description	Package
U2309B	Front end mixer and oscillator	SO28/ SSO28
U2750B*	Front end mixer, oscillator and AGC generation	SSO28
U2752M	Digital I/Q generation	SO24
U2753B-B	PLL for front end	SSO20
U2753B-C	PLL including frequency doubler for front end	SSO20
U2754B-B	PLL for L band down-converter	SSO20
U2755B-1/ U2755B-2	L band amplifier and mixer for down-converter	SSO20
U2755B-B	L band amplifier, mixer and VCO for down-converter	SSO20
U2756M	Audio source decoder	PLCC44
U2757M-B	FFT/IFFT processing for channel decoder/encoder (mode IV)	TQFP100
U2758M-B*	De-interleaver, program selector and Viterbi decoder for channel decoder (mode IV)	TQFP100
U2759B	IF processing	SO24

\* = under development, will be available in June 96