

Features

- Includes IF Amplifier, Quadrature Detector, AF Pre-amplifier, and Specific Circuits for AGC, AFC, Tuning Meter, Deviation-Noise Muting, and ON Channel Detector
- FM IF Amplifier Applications in High-Fidelity, Automotive, and Communications Receivers
- Exceptional Limiting Sensitivity $-12\mu\text{V}$ (Typ) at -3dB Point
- Low Distortion -0.1% (Typ) (with Double-Tuned Coil)
- Single-Coil Tuning Capability
- Improved S + N/N Ratio
- Externally Programmable Recovered Audio Level
- Provides Specific Signal for Control of Interchannel Muting (Squelch)
- Provides Specific Signal for Direct Drive of a Tuning Meter
- On Channel Step for Search Control
- Provides Programmable AGC Voltage for RF Amplifier
- Provides a Specific Circuit for Flexible Audio Output
- Internal Supply Voltage Regulators
- Externally Programmable "On" Channel Step Width, and Deviation at Which Muting Occurs

Description

The Harris CA3189E is a monolithic integrated circuit that provides all the functions of a comprehensive FM-IF system. The block diagram of the CA3189E includes a three-stage FM-IF amplifier/limiter configuration with level detectors for each stage, a doubly-balanced quadrature FM detector and an audio amplifier that features the optional use of a muting (squelch) circuit.

The advanced circuit design of the IF system includes desirable deluxe features such as programmable delayed AGC for the RF tuner, an AFC drive circuit, and an output signal to drive a tuning meter and/or provide stereo switching logic. In addition, internal power-supply regulators maintain a nearly constant current drain over the voltage supply range of $+8.5\text{V}$ to $+16\text{V}$.

The CA3189E is ideal for high-fidelity operation. Distortion in a CA3189E FM-IF System is primarily a function of the phase linearity characteristic of the outboard detector coil. The CA3189E has all the features of the CA3089E plus additions. See CA3189E features compared to the CA3089E in Table 1.

Ordering Information

| PART NUMBER | TEMP. RANGE (°C) | PACKAGE | PKG. NO. |
|-------------|------------------|------------|----------|
| CA3189E | -40 to 85 | 16 Ld PDIP | E16.3 |

Pinout

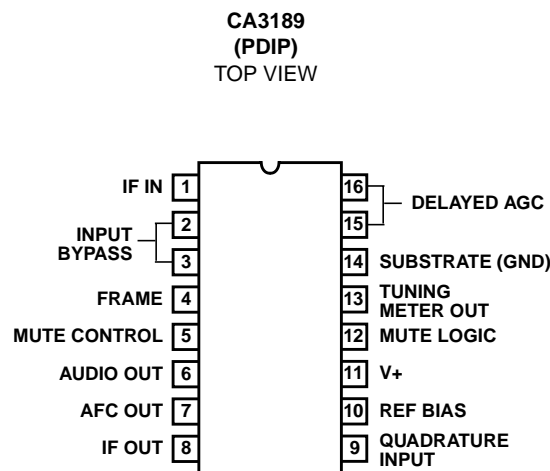

CA3189

Absolute Maximum Ratings

| | |
|---------------------------------|-----|
| DC Supply Voltage | |
| (Between Terminals 11 and 4) | 16V |
| (Between Terminals 11 and 14) | 16V |
| DC Current (Out of Terminal 15) | 2mA |

Thermal Information

| | |
|------------------------------------------------|----------------------|
| Thermal Resistance (Typical, Note 1) | θ_{JA} (°C/W) |
| PDIP Package | 90 |
| Maximum Junction Temperature (Plastic Package) | 150°C |
| Maximum Storage Temperature Range | -65°C to 150°C |
| Maximum Lead Temperature (Soldering 10s) | 300°C |

Operating Conditions

Temperature Range -40°C to 85°C

CAUTION: Stresses above those listed in "Absolute Maximum Ratings" may cause permanent damage to the device. This is a stress only rating and operation of the device at these or any other conditions above those indicated in the operational sections of this specification is not implied.

NOTE:

- θ_{JA} is measured with the component mounted on an evaluation PC board in free air.

Electrical Specifications $T_A = 25^\circ\text{C}$, $V_+ = 12\text{V}$

| PARAMETER | SYMBOL | TEST CONDITIONS | CIRCUIT OR FIG. NO. | MIN | TYP | MAX | UNITS |
|-----------------------------------------------|--------------|-------------------------------------------|---------------------|-----|----------|-----|---------------|
| DC SPECIFICATIONS | | | | | | | |
| Quiescent Circuit Current | I_{11} | No Signal Input, Non Muted | 1, 2 | 20 | 31 | 40 | mA |
| DC Voltages | | No Signal Input, Non Muted | | | | | |
| Terminal 1 (IF Input) | V_1 | | 1, 2 | 1.2 | 1.9 | 2.4 | V |
| Terminal 2 (AC Return to Input) | V_2 | | 1, 2 | 1.2 | 1.9 | 2.4 | V |
| Terminal 3 (DC Bias to Input) | V_3 | | 1, 2 | 1.2 | 1.9 | 2.4 | V |
| Terminal 15 (RF AGC) | V_{15} | | 1, 2 | 7.5 | 9.5 | 11 | V |
| Terminal 10 (DC Reference) | V_{10} | | 1, 2 | 5 | 5.6 | 6 | V |
| DYNAMIC SPECIFICATIONS | | | | | | | |
| Input Limiting Voltage (-3dB Point) | $V_{I(lim)}$ | | 1, 2 | - | 12 | 25 | μV |
| AM Rejection (Terminal 6) | AMR | $V_{IN} = 0.1\text{V}$, AM Mod. = 30% | 1, 2 | 45 | 55 | - | dB |
| Recovered AF Voltage (Terminal 6) | $V_{O(AF)}$ | | 1, 2 | 325 | 500 | 650 | mV |
| Total Harmonic Distortion (Note 2) | | | | | | | |
| Single Tuned (Terminal 6) | THD | $V_{IN} = 0.1\text{V}$ | 1 | - | 0.5 | 1 | % |
| Double Tuned (Terminal 6) | THD | | 2 | - | 0.1 | - | % |
| Signal Plus Noise to Noise Ratio (Terminal 6) | S + N/N | $V_{IN} = 0.1\text{V}$ | 1, 2 | 65 | 72 | - | dB |
| Deviation Mute Frequency | f_{DEV} | | 1, 5, 6 | - | ± 40 | - | kHz |
| RF AGC Threshold | V_{16} | | 1, 2 | - | 1.25 | - | V |
| On Channel Step | V_{12} | $V_{IN} = 0.1\text{V}$ | | | | | |
| | | | 1 | - | 0 | - | V |
| | | | 1 | - | 5.6 | - | V |

NOTE:

- THD characteristics are essentially a function of the phase characteristics of the network connected between Terminals 8, 9, and 10.

CA3189

TABLE 1. CA3189E FEATURES COMPARED TO CA3089E

| FEATURES | CA3189E | CA3089E |
|---------------------------------------------------------|---------|---------|
| Low Limiting Sensitivity (12μV Typ) | Yes | Yes |
| Low Distortion | Yes | Yes |
| Single-Coil Tuning Capability | Yes | Yes |
| Programmable Audio Level | Yes | No |
| S/N Mute | Yes | Yes |
| Deviation Mute | Yes | No |
| Flexible AFC | Yes | Yes |
| Programmable AGC Threshold and Voltage | Yes | No |
| Typical S + N/N > 70 dB | Yes | No |
| Meter Drive Voltage Depressed at Very Low Signal Levels | Yes | No |
| On-Channel Step Control Voltage | Yes | No |

Test Circuits

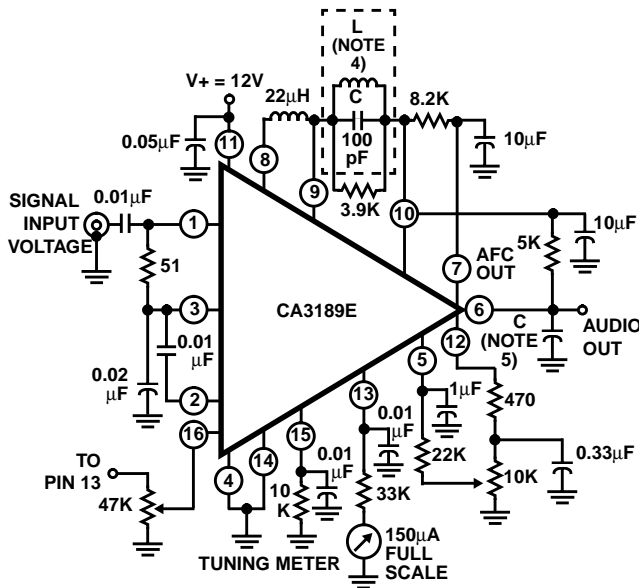

NOTES:

- All resistance values are in ohms.
- L tunes with 100pF (C) at 10.7MHz. Q_0 (unloaded) $\cong 75$ (TOKO No. KACS K586HM or equivalent).
- C = 0.01μF for 50μs deemphasis (Europe).
C = 0.015μF for 75μs deemphasis (USA).

FIGURE 1. TEST CIRCUIT FOR CA3189E USING A SINGLE-TUNED DETECTOR COIL

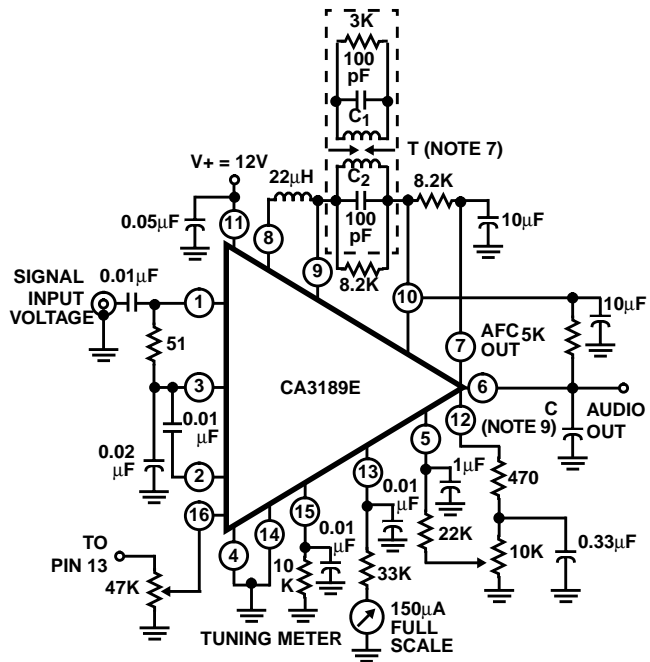

NOTES:

- All resistance values are in ohms.
- T: PRI. - Q_0 (unloaded) $\cong 75$ (tunes with 100pF (C_1)) 20↑ of 34e on $7/32$ " dia. form. SEC. - Q_0 (unloaded) $\cong 75$ (tunes with 100pF (C_2)) 20↑ of 34e on $7/32$ " dia. form. kQ (percent of critical coupling) $\cong 70\%$ (Adjusted for coil voltage (V_C) = 150mV).
- Above values permit proper operation of mute (squelch) circuit "E" type slugs, spacing 4mm.
- C = 0.01μF for 50μs deemphasis (Europe) C = 0.015μF for 75μs deemphasis (USA).

FIGURE 2. TEST CIRCUIT FOR CA3189E USING A DOUBLE-TUNED DETECTOR COIL

Block Diagram

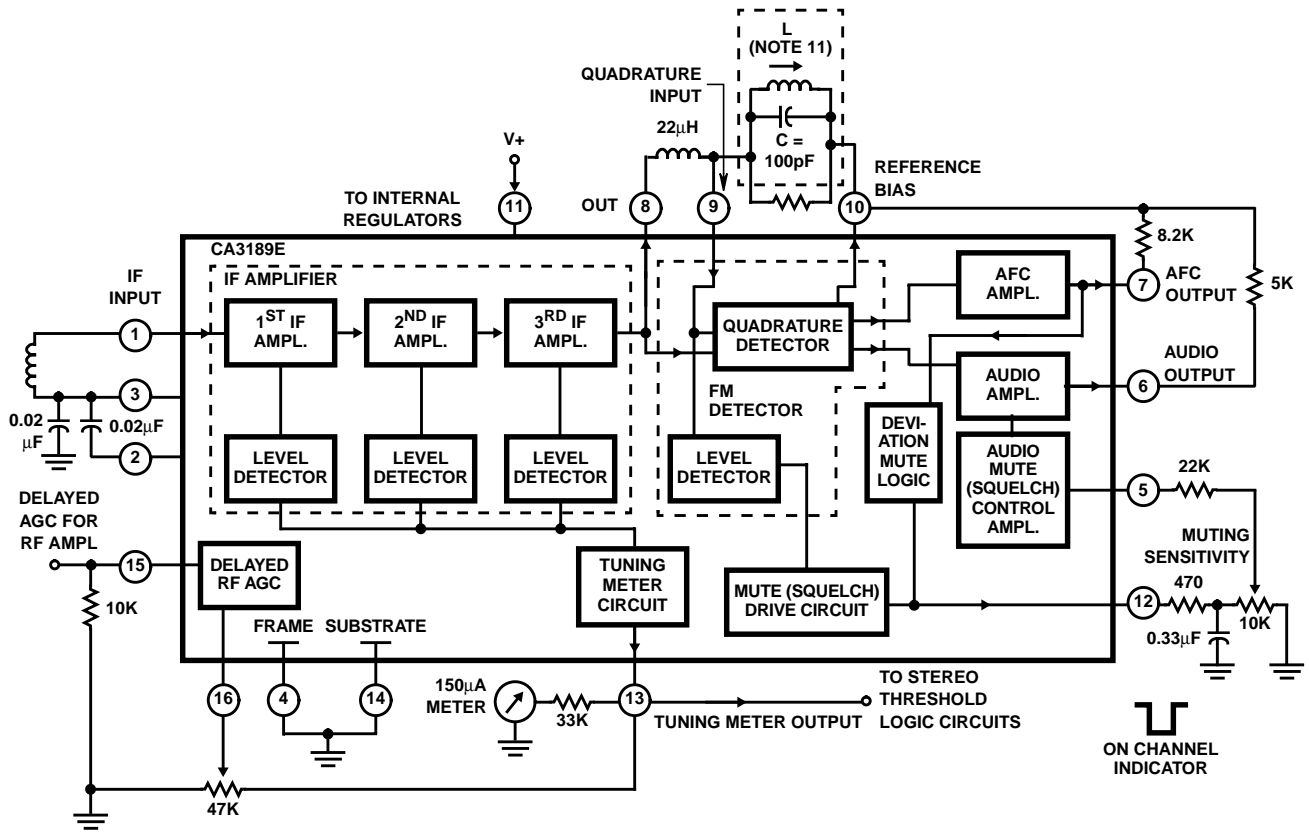

NOTES:

10. All resistance values are in Ω .

11. L Tunes with 100pF (C) at 10.7MHz. $Q_0 \cong 75$ (TOKO No. KACS K586HM or equivalent).

Schematic Diagrams

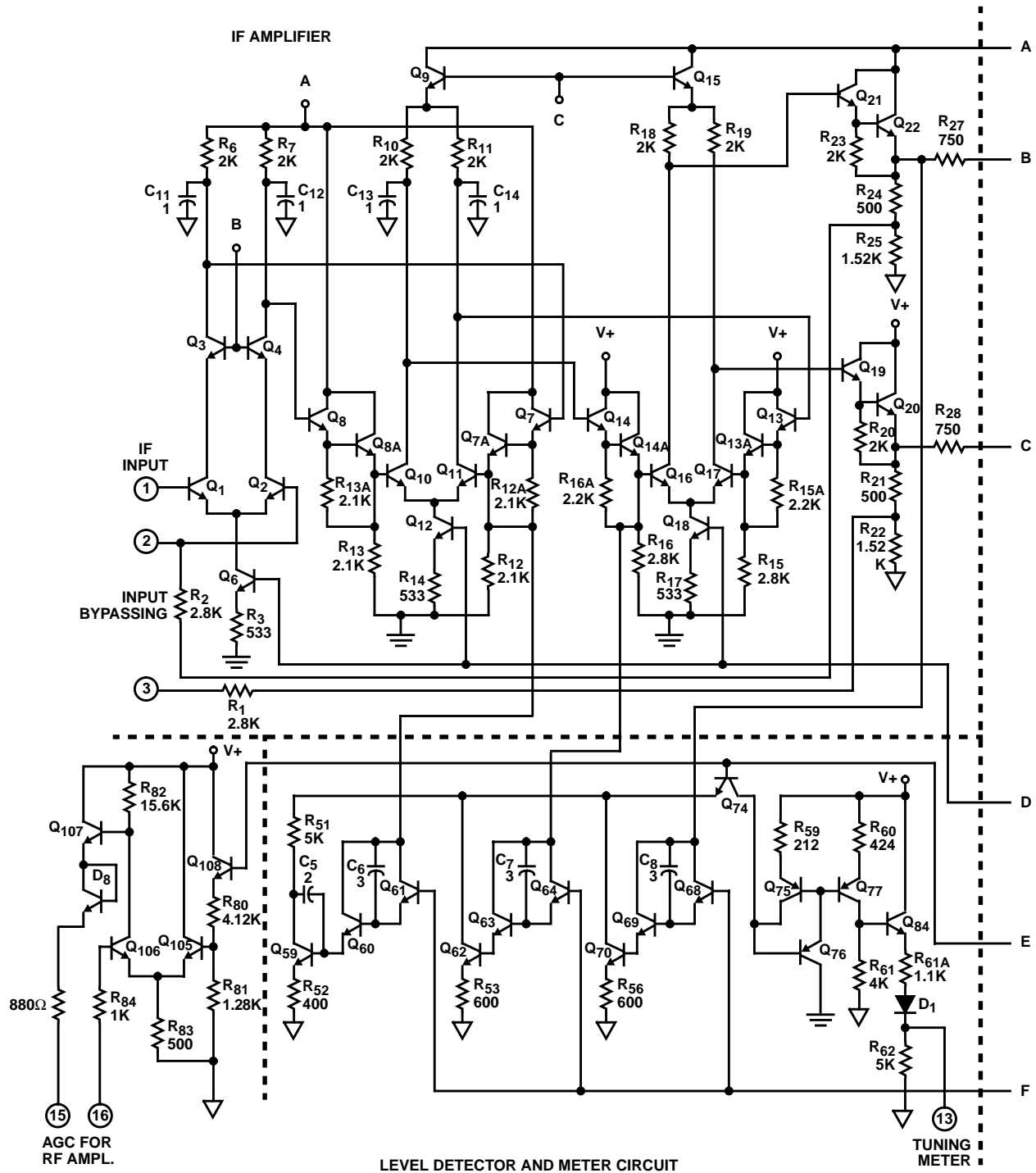

Schematic Diagrams (Continued)

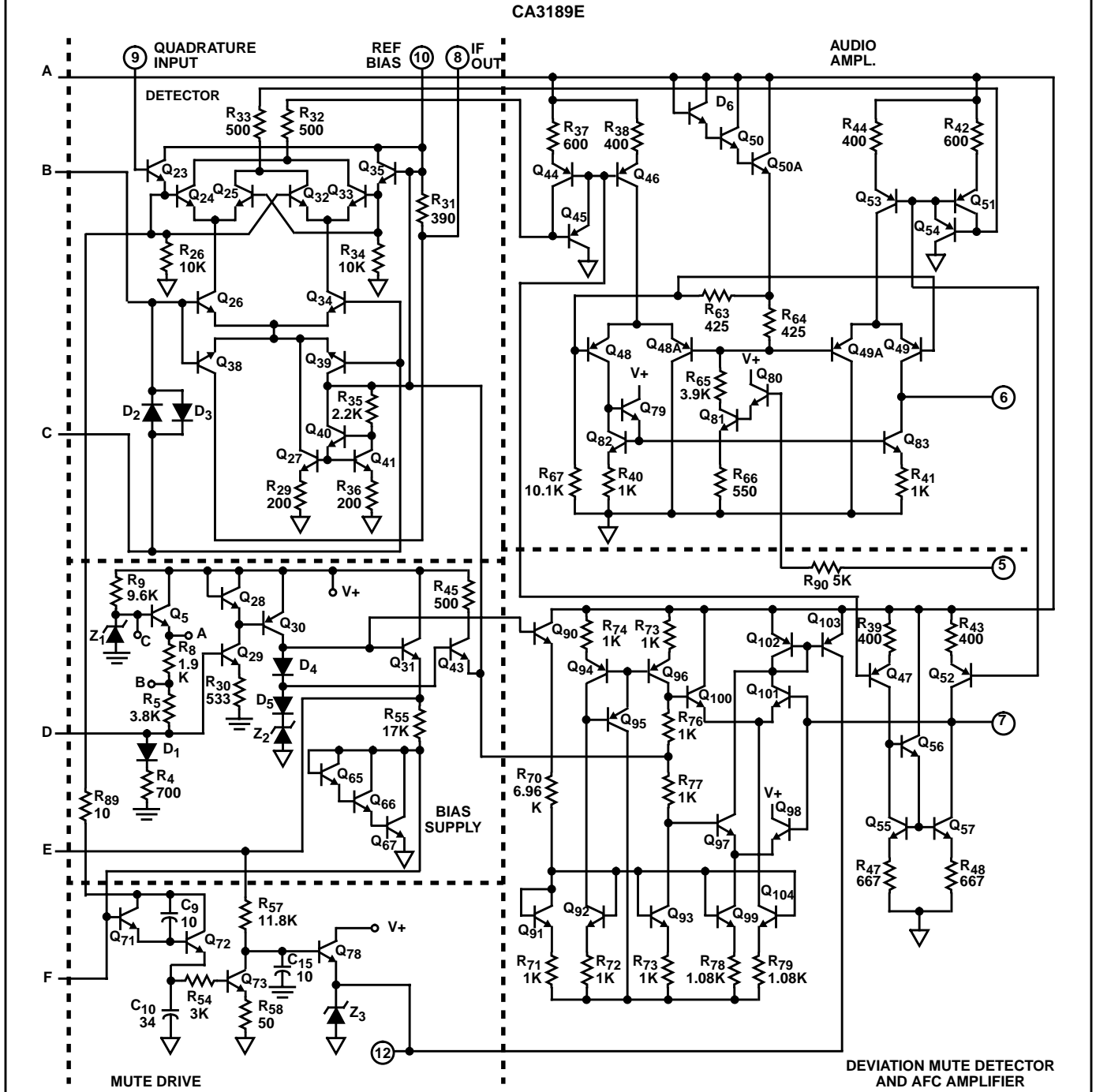

Typical Application

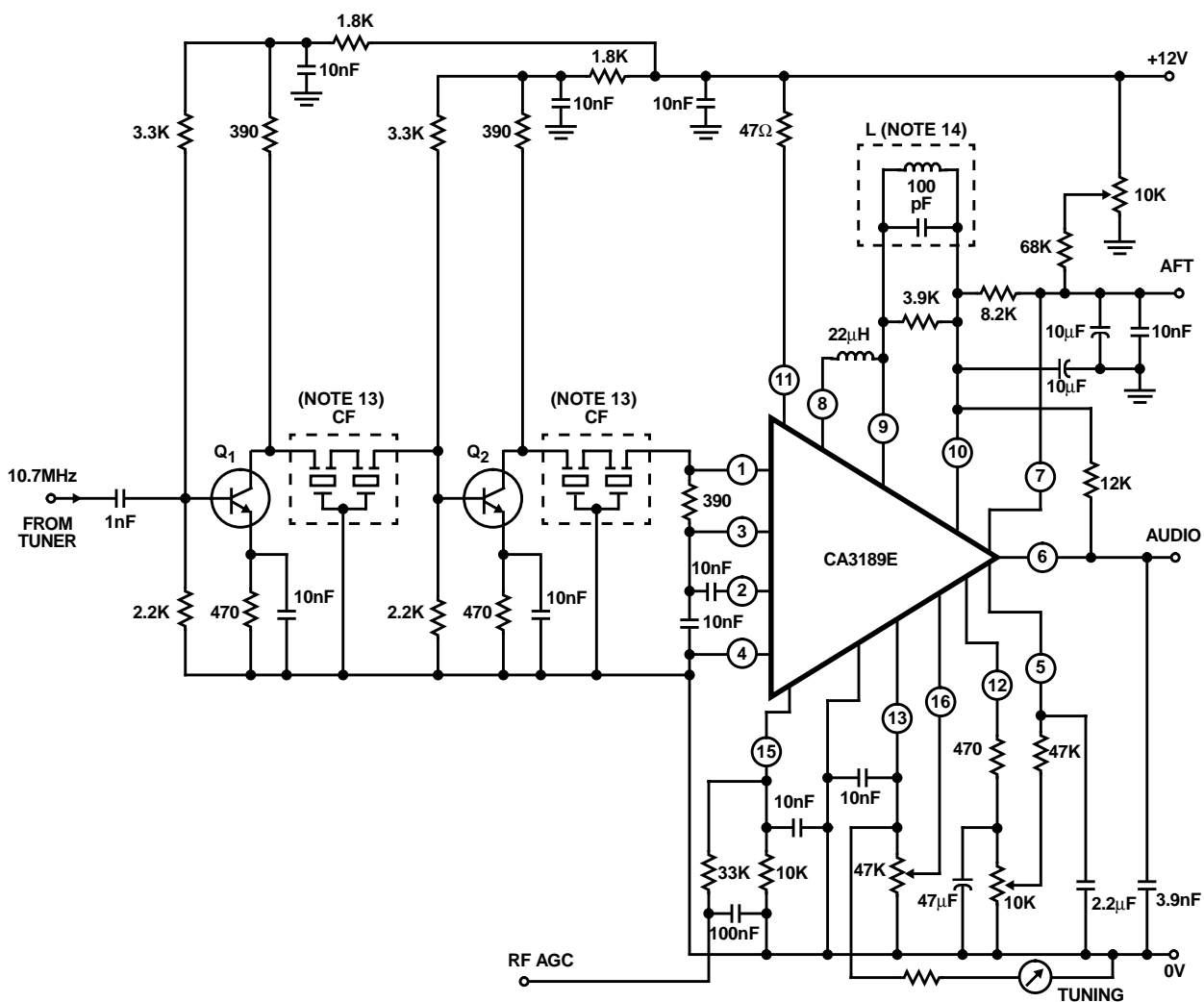

NOTES:

12. All resistance values are in ohms.
13. CF: Ceramic filters, TOKO CSFE or equivalent.
14. L tunes with 100pF (C) at 10.7MHz. Q_0 (unloaded) $\cong 75$ (TOKO No. KACS K586HM or equivalent).

FIGURE 3. COMPLETE FM IF SYSTEM FOR HIGH QUALITY RECEIVERS

Typical Performance Curves

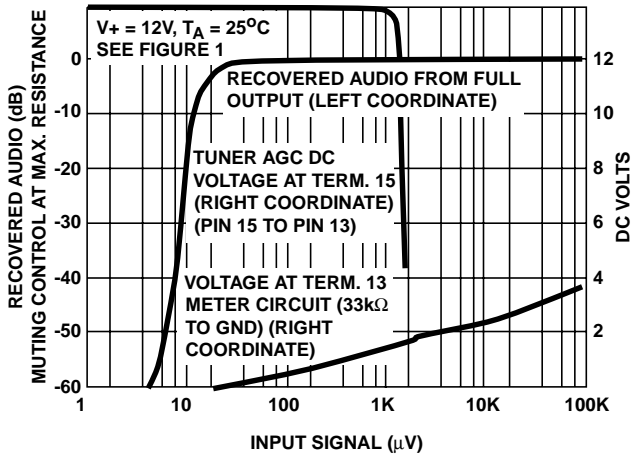

FIGURE 4. MUTING ACTION, TUNER AGC, AND TUNING METER OUTPUT vs INPUT SIGNAL VOLTAGE

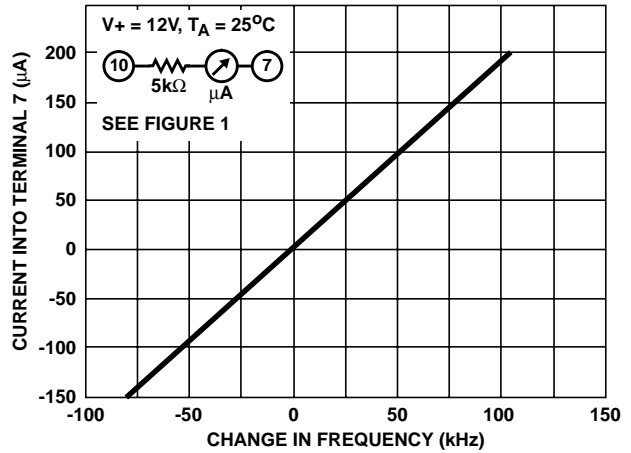

FIGURE 5. AFC CHARACTERISTICS (CURRENT AT TERMINAL 7 vs CHANGE IN FREQUENCY)

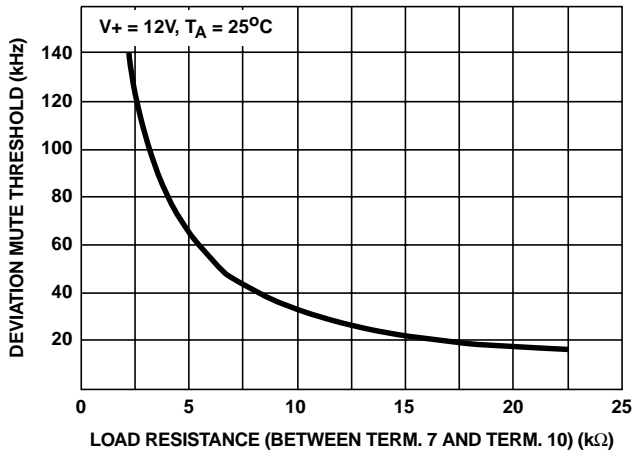

FIGURE 6. DEVIATION MUTE THRESHOLD vs LOAD RESISTANCE (BETWEEN TERMINAL 7 AND TERMINAL 10)

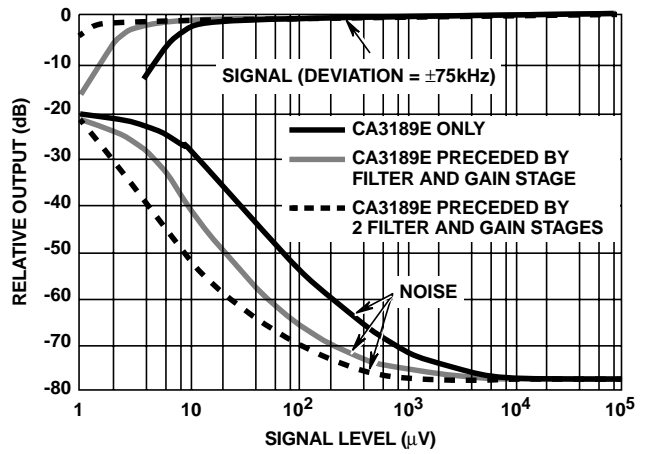

FIGURE 7. TYPICAL LIMITING AND NOISE CHARACTERISTICS