

## Silicon Transient Voltage Suppressors

### Features

- Glass passivated junction
- High reliability
- Stand-off voltage range 8.2V to 220V
- Excellent clamping capability
- Fast response time (typ.  $\leq 1\text{ps}$  from 0 to  $V_{Zmin}$ )

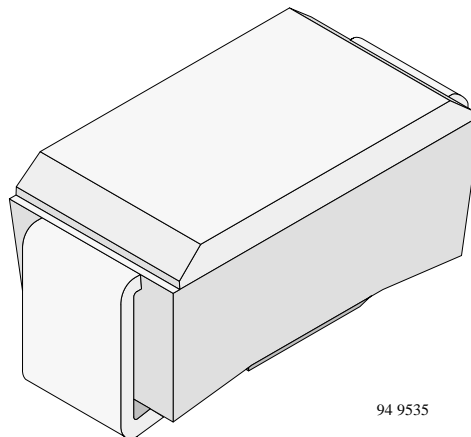

94 9535

### Applications

Protection from high voltage, high energy transients

### Absolute Maximum Ratings

$T_j = 25^\circ\text{C}$

Parameter	Test Conditions	Type	Symbol	Value	Unit
Power dissipation	$R_{thJA} < 25\text{K/W}$ , $T_{amb} = 100^\circ\text{C}$		$P_V$	3	W
	$R_{thJA} < 100\text{K/W}$ , $T_{amb} = 50^\circ\text{C}$		$P_V$	1.25	W
Non repetitive peak surge power dissipation	$t_p = 10/1000\mu\text{s}$ sq.pulse, $T_j = 25^\circ\text{C}$ prior to surge		PZSM	300	W
Peak forward surge current	10ms single half sine wave		$I_{FSM}$	50	A
Junction temperature			$T_j$	175	$^\circ\text{C}$
Storage temperature range			$T_{stg}$	-65...+150	$^\circ\text{C}$

### Maximum Thermal Resistance

$T_j = 25^\circ\text{C}$

Parameter	Test Conditions	Symbol	Value	Unit
Junction lead		$R_{thJL}$	25	K/W
Junction ambient	mounted on epoxy-glass hard tissue, Fig. 1a	$R_{thJA}$	150	K/W
	mounted on epoxy-glass hard tissue, Fig. 1b	$R_{thJA}$	125	K/W
	mounted on Al-oxid-ceramic ( $\text{Al}_2\text{O}_3$ ), Fig. 1b	$R_{thJA}$	100	K/W

### Characteristics

$T_j = 25^\circ\text{C}$

Parameter	Test Conditions	Type	Symbol	Min	Typ	Max	Unit
Forward voltage	$I_F = 0.5\text{A}$		$V_F$			1.2	V

Type BZG04...	Stand-off Voltage		Breakdown Voltage		Clamping Voltage	
	$V_R$	$I_R$	$V_{(BR)}$ at $I_R$		$V_{CL(R)}$ at $I_{PP}^*)$	
	V	$\mu A$	V	mA	V	A
		Max.	Min.		Max.	
8V2	8.2	20	9.4	50	14.8	20.3
9V1	9.1	5	10.4	50	15.7	19.1
10	10	5	11.4	50	17.0	17.7
11	11	5	12.4	50	18.9	15.9
12	12	5	13.8	50	20.9	14.4
13	13	5	15.3	25	22.9	13.1
15	15	5	16.8	25	25.6	11.7
16	16	5	18.8	25	28.4	10.6
18	18	5	20.8	25	31.0	9.7
20	20	5	22.8	25	33.8	8.9
22	22	5	25.1	25	38.1	7.9
24	24	5	28	25	42.2	7.1
27	27	5	31	25	46.2	6.5
30	30	5	34	10	50.1	6.0
33	33	5	37	10	54.1	5.5
36	36	5	40	10	60.7	4.9
39	39	5	44	10	65.5	4.6
43	43	5	48	10	70.8	4.2
47	47	5	52	10	78.6	3.8
51	51	5	58	10	86.5	3.5
56	56	5	64	10	94.4	3.2
62	62	5	70	10	103.5	2.9
68	68	5	77	10	114	2.6
75	75	5	85	5	126	2.4
82	82	5	94	5	139	2.2
91	91	5	104	5	152	2.0
100	100	5	114	5	167	1.8
110	110	5	124	5	185	1.6
120	120	5	138	5	204	1.5
130	130	5	153	5	224	1.3
150	150	5	168	5	249	1.2
160	160	5	188	5	276	1.1
180	180	5	208	2	305	1.0
200	200	5	228	2	336	0.9
220	220	5	251	2	380	0.8

\*) 10/1000  $\mu s$  pulse

**Typical Characteristics** ( $T_j = 25^\circ\text{C}$  unless otherwise specified)

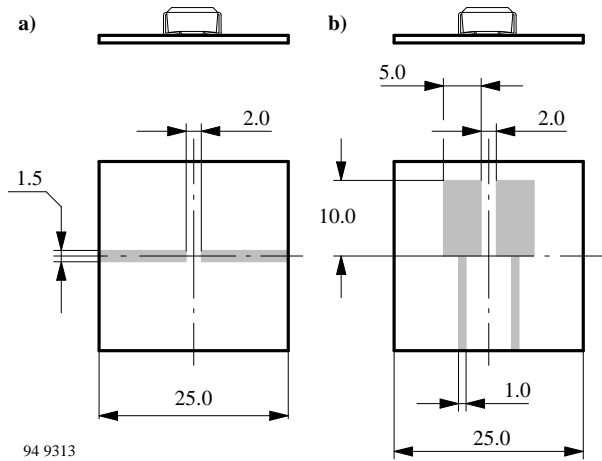

Figure 1. Boards for  $R_{thJA}$  definition (copper overlay 35 $\mu$ )

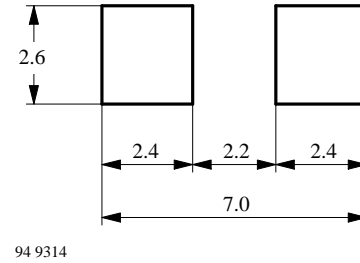

Figure 2. Recommended foot pads (in mm)

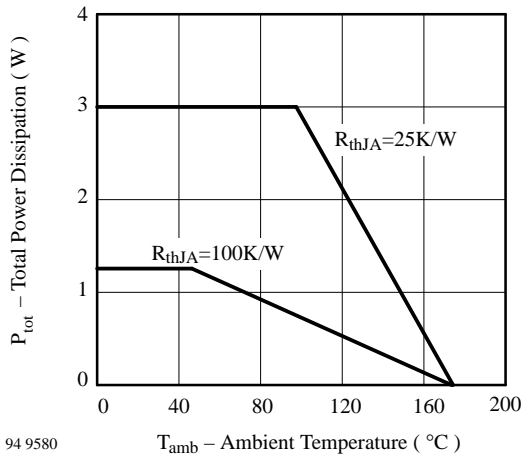

Figure 3. Total Power Dissipation vs. Ambient Temperature

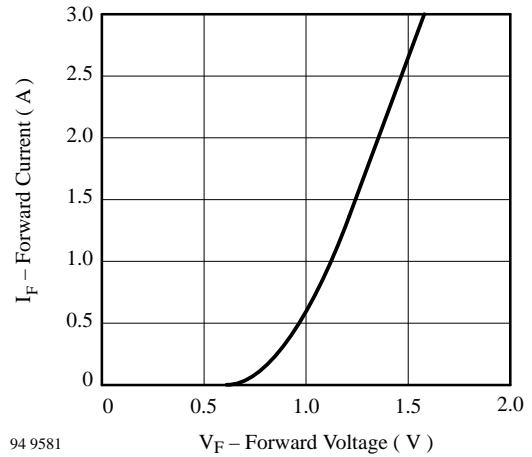
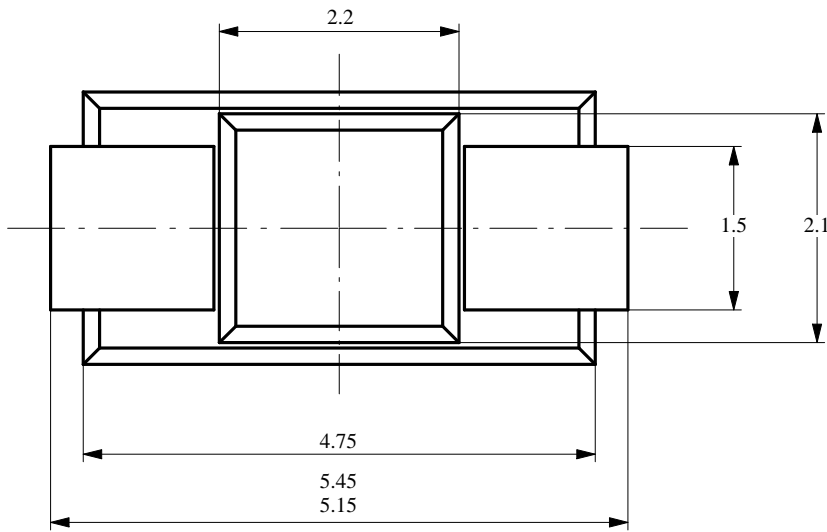



Figure 4. Forward Current vs. Forward Voltage

## Dimensions in mm



  
technical drawings  
according to DIN  
specifications

Plastic Case  
JEDEC DO 214 AC  
SOD 106 A

Cathode indicated by a Band

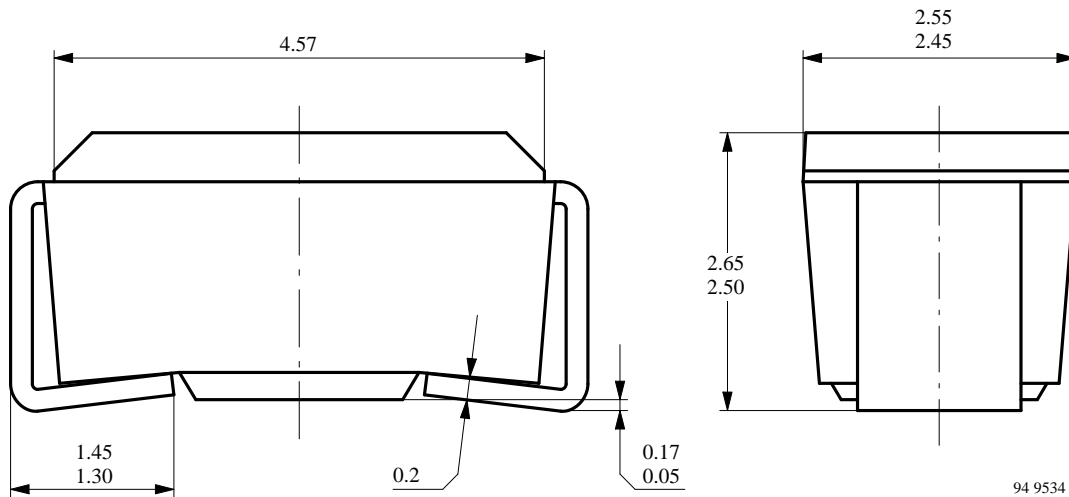

94 9534

## Ozone Depleting Substances Policy Statement

It is the policy of **TEMIC TELEFUNKEN microelectronic GmbH** to

1. Meet all present and future national and international statutory requirements.
2. Regularly and continuously improve the performance of our products, processes, distribution and operating systems with respect to their impact on the health and safety of our employees and the public, as well as their impact on the environment.

It is particular concern to control or eliminate releases of those substances into the atmosphere which are known as ozone depleting substances (ODSs).

The Montreal Protocol (1987) and its London Amendments (1990) intend to severely restrict the use of ODSs and forbid their use within the next ten years. Various national and international initiatives are pressing for an earlier ban on these substances.

**TEMIC TELEFUNKEN microelectronic GmbH** semiconductor division has been able to use its policy of continuous improvements to eliminate the use of ODSs listed in the following documents.

1. Annex A, B and list of transitional substances of the Montreal Protocol and the London Amendments respectively
2. Class I and II ozone depleting substances in the Clean Air Act Amendments of 1990 by the Environmental Protection Agency (EPA) in the USA
3. Council Decision 88/540/EEC and 91/690/EEC Annex A, B and C (transitional substances) respectively.

**TEMIC** can certify that our semiconductors are not manufactured with ozone depleting substances and do not contain such substances.

**We reserve the right to make changes to improve technical design and may do so without further notice.**

Parameters can vary in different applications. All operating parameters must be validated for each customer application by the customer. Should the buyer use TEMIC products for any unintended or unauthorized application, the buyer shall indemnify TEMIC against all claims, costs, damages, and expenses, arising out of, directly or indirectly, any claim of personal damage, injury or death associated with such unintended or unauthorized use.

TEMIC TELEFUNKEN microelectronic GmbH, P.O.B. 3535, D-74025 Heilbronn, Germany  
Telephone: 49 (0)7131 67 2831, Fax number: 49 (0)7131 67 2423