

Silicon Mesa Rectifier

Features

- Controlled avalanche characteristics
- Glass passivated junction
- Hermetically sealed package
- Low reverse current
- High surge current capability

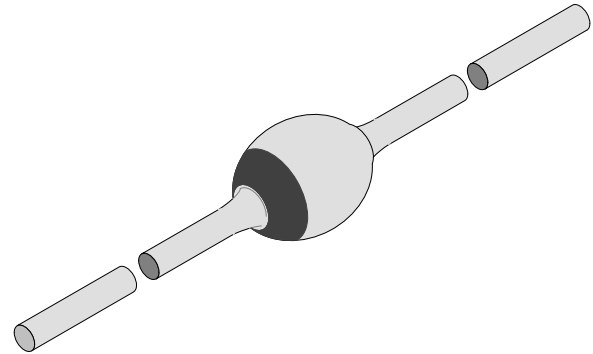

94 9539

Applications

General purpose

Absolute Maximum Ratings

$T_j = 25^\circ\text{C}$

Parameter	Test Conditions	Type	Symbol	Value	Unit
Peak reverse voltage, non repetitive			V_{RSM}	1250	V
Reverse voltage			V_R	800	V
Peak forward surge current	$t_p=10\text{ms}$		I_{FSM}	50	A
Repetitive peak forward current			I_{FRM}	12	A
Average forward current	$\phi=180^\circ$		I_{FAV}	2	A
Pulse avalanche peak power	$T_j=175^\circ\text{C}$, $t_p=20\mu\text{s}$, half sinus wave		P_R	1000	W
Max. pulse energy in avalanche mode, non repetitive (inductive load switch off)	$I_{(BR)R}=1\text{A}$, $T_j=175^\circ\text{C}$		E_R	20	mWs
	$i^2\text{xt}$ -rating		$i^2\text{xt}$	8	A^2xs
Junction temperature			T_j	175	$^\circ\text{C}$
Storage temperature range			T_{stg}	-55...+150	$^\circ\text{C}$

Maximum Thermal Resistance

$T_j = 25^\circ\text{C}$

Parameter	Test Conditions	Symbol	Value	Unit
Junction ambient	$l=10\text{mm}$, $T_L=\text{constant}$	R_{thJA}	45	K/W
	on PC board with spacing 25mm	R_{thJA}	100	K/W

Characteristics

$T_j = 25^\circ\text{C}$

Parameter	Test Conditions	Type	Symbol	Min	Typ	Max	Unit
Forward voltage	$I_F=1\text{A}$		V_F		0.9	1.0	V
	$I_F=10\text{A}$		V_F			1.65	V
Reverse current	$V_R=800\text{V}$		I_R		0.1	1	μA
	$V_R=800\text{V}, T_j=100^\circ\text{C}$		I_R		5	10	μA
Breakdown voltage	$I_R=100\mu\text{A}, t_p/T=0.01,$ $t_p=0.3\text{ms}$		$V_{(BR)}$	1250			V
Diode capacitance	$V_R=0, f=0.47\text{MHz}$		C_D		50		pF
Reverse recovery time	$I_F=0.5\text{A}, I_R=1\text{A},$ $i_R=0.25\text{A}$		t_{rr}			4	μs
	$I_F=1\text{A}, d_i/d_t=5\text{A}/\mu\text{s},$ $V_R=50\text{V}$		t_{rr}			4	μs
Reverse recovery charge	$I_F=1\text{A}, d_i/d_t=5\text{A}/\mu\text{s}$		Q_{rr}			3	μC

Typical Characteristics ($T_j = 25^\circ\text{C}$ unless otherwise specified)

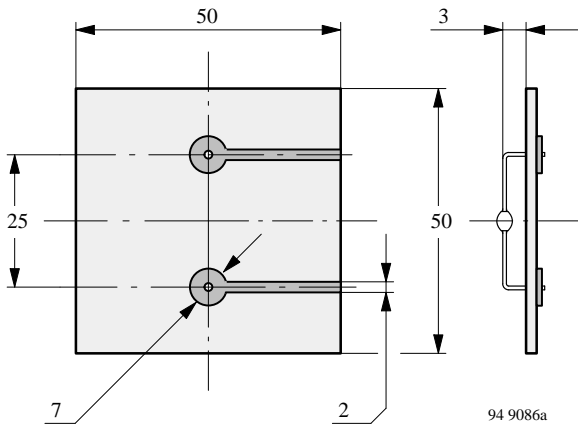

Figure 1. Epoxy glass hard tissue, board thickness 1.5 mm,
 $R_{thJA} \leq 100 \text{ K/W}$

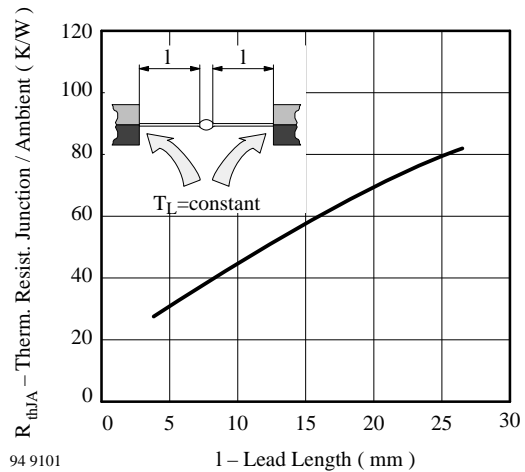

Figure 2. Thermal Resistance vs. Lead Length

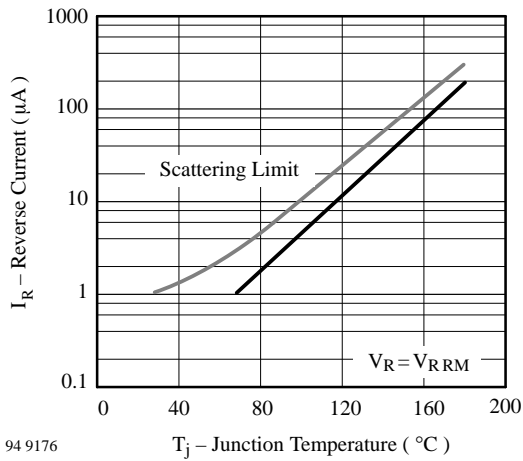

Figure 3. Reverse Current vs. Junction Temperature

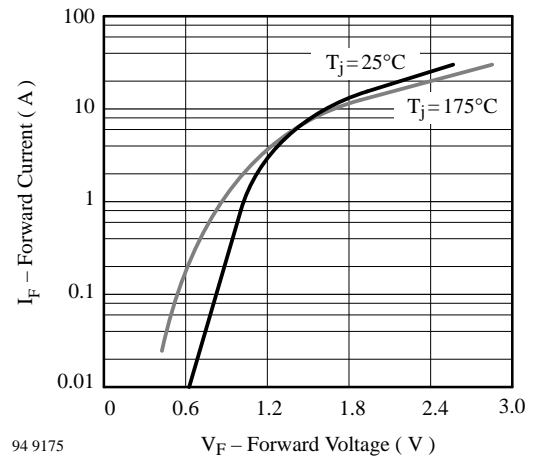

Figure 6. Forward Current vs. Forward Voltage

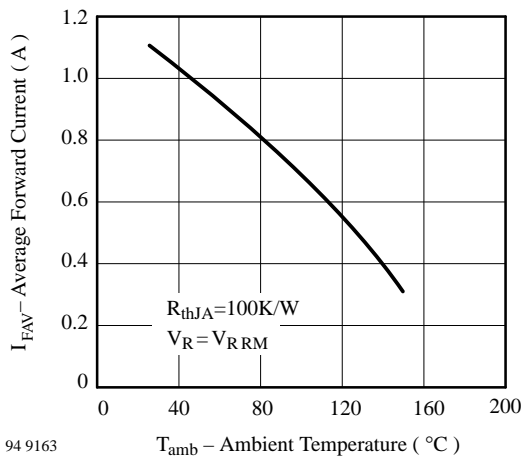

Figure 4. Average Forward Current vs. Ambient Temperature

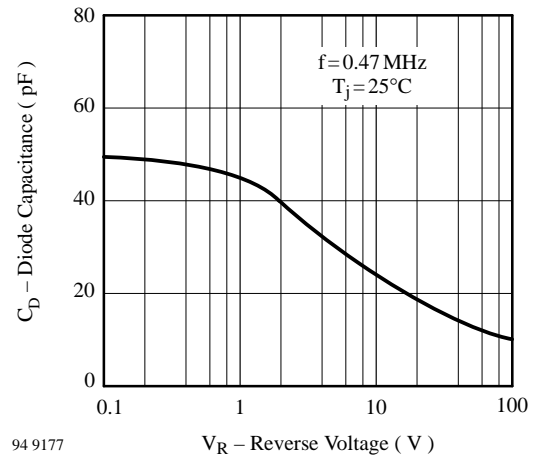

Figure 7. Diode Capacitance vs. Reverse Voltage

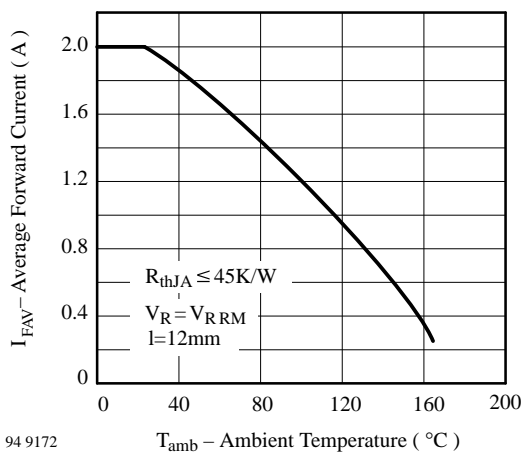

Figure 5. Average Forward Current vs. Ambient Temperature

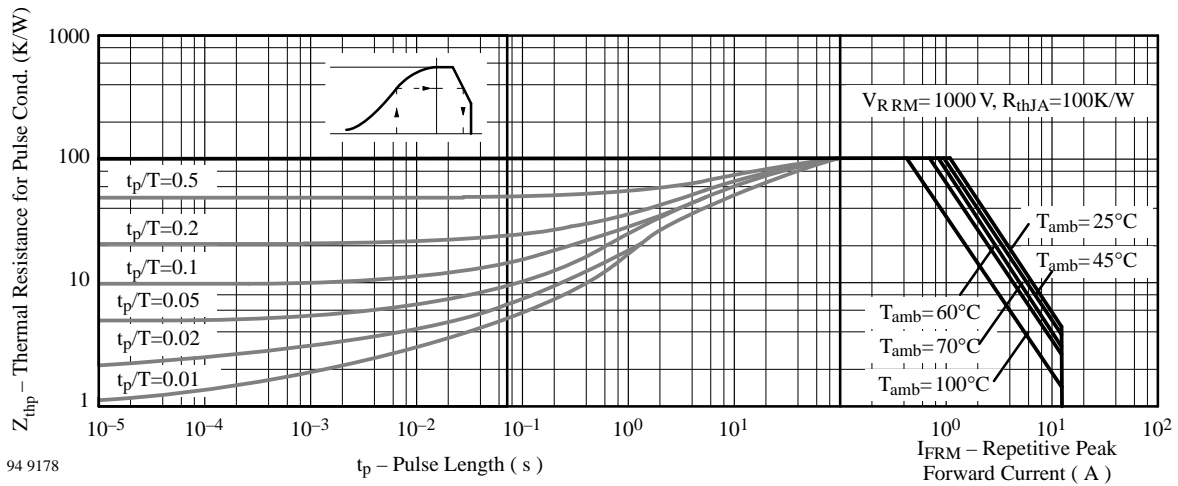
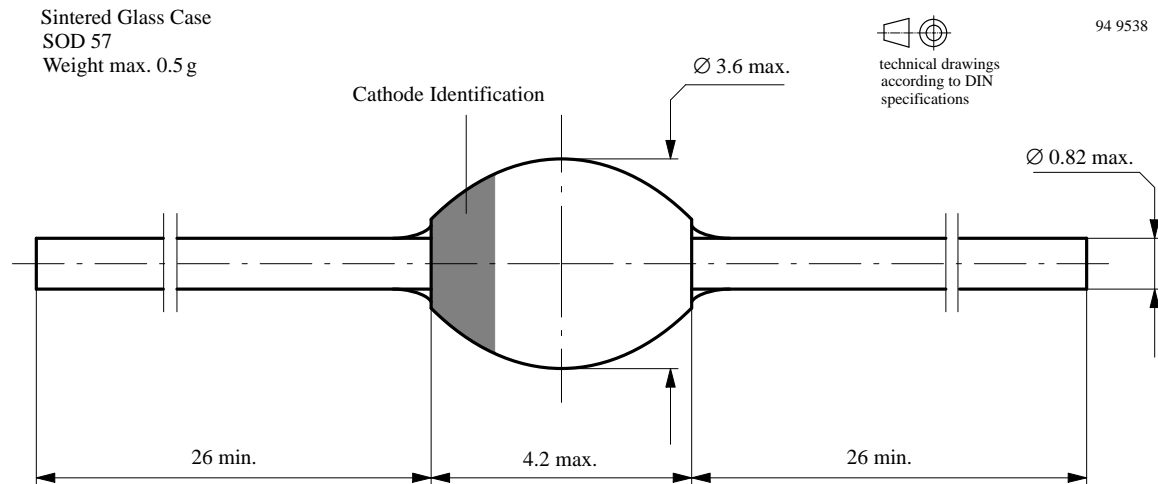

Figure 8. Thermal Response

Dimensions in mm



Ozone Depleting Substances Policy Statement

It is the policy of **TEMIC TELEFUNKEN microelectronic GmbH** to

1. Meet all present and future national and international statutory requirements.
2. Regularly and continuously improve the performance of our products, processes, distribution and operating systems with respect to their impact on the health and safety of our employees and the public, as well as their impact on the environment.

It is particular concern to control or eliminate releases of those substances into the atmosphere which are known as ozone depleting substances (ODSs).

The Montreal Protocol (1987) and its London Amendments (1990) intend to severely restrict the use of ODSs and forbid their use within the next ten years. Various national and international initiatives are pressing for an earlier ban on these substances.

TEMIC TELEFUNKEN microelectronic GmbH semiconductor division has been able to use its policy of continuous improvements to eliminate the use of ODSs listed in the following documents.

1. Annex A, B and list of transitional substances of the Montreal Protocol and the London Amendments respectively
2. Class I and II ozone depleting substances in the Clean Air Act Amendments of 1990 by the Environmental Protection Agency (EPA) in the USA
3. Council Decision 88/540/EEC and 91/690/EEC Annex A, B and C (transitional substances) respectively.

TEMIC can certify that our semiconductors are not manufactured with ozone depleting substances and do not contain such substances.

We reserve the right to make changes to improve technical design and may do so without further notice.

Parameters can vary in different applications. All operating parameters must be validated for each customer application by the customer. Should the buyer use TEMIC products for any unintended or unauthorized application, the buyer shall indemnify TEMIC against all claims, costs, damages, and expenses, arising out of, directly or indirectly, any claim of personal damage, injury or death associated with such unintended or unauthorized use.

TEMIC TELEFUNKEN microelectronic GmbH, P.O.B. 3535, D-74025 Heilbronn, Germany
Telephone: 49 (0)7131 67 2831, Fax number: 49 (0)7131 67 2423