

Silicon NPN Planar RF Transistor

Applications

RF-amplifier up to GHz range specially for wide band antenna amplifier.

Features

- High power gain
- Low noise figure
- High transition frequency

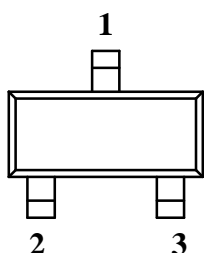

94 9280

BFR92 Marking: P1
Plastic case (SOT 23)
1= Collector; 2= Base; 3= Emitter

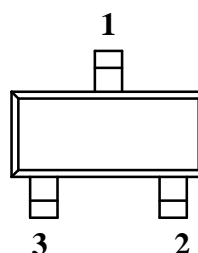

95 10527

BFR92R Marking: P4
Plastic case (SOT 23)
1= Collector; 2= Base; 3= Emitter

Absolute Maximum Ratings

Parameters	Symbol	Value	Unit
Collector-base voltage	V_{CBO}	20	V
Collector-emitter voltage	V_{CEO}	15	V
Emitter-base voltage	V_{EBO}	2	V
Collector current	I_C	30	mA
Total power dissipation $T_{amb} \leq 60^\circ\text{C}$	P_{tot}	200	mW
Junction temperature	T_j	150	$^\circ\text{C}$
Storage temperature range	T_{stg}	-65 to +150	$^\circ\text{C}$

Maximum Thermal Resistance

Parameters	Symbol	Value	Unit
Junction ambient on glass fibre printed board (25 x 20 x 1.5) mm ³ plated with 35 μm Cu	R_{thJA}	450	K/W

Electrical DC Characteristics

$T_{amb} = 25^{\circ}\text{C}$, unless otherwise specified

Parameters / Test Conditions	Symbol	Min.	Typ.	Max.	Unit
Collector-emitter cut-off current $V_{CE} = 20\text{ V}, V_{BE} = 0$	I_{CES}			100	μA
Collector-base cut-off current $V_{CB} = 10\text{ V}, I_E = 0$	I_{CBO}			100	nA
Emitter-base cut-off current $V_{EB} = 2\text{ V}, I_C = 0$	I_{EBO}			10	μA
Collector-emitter breakdown voltage $I_C = 1\text{ mA}, I_B = 0$	$V_{(BR)CEO}$	15			V
DC forward current transfer ratio $V_{CE} = 10\text{ V}, I_C = 14\text{ mA}$	h_{FE}	25	50	150	

Electrical AC Characteristics

$T_{amb} = 25^{\circ}\text{C}$

Parameters / Test Conditions	Symbol	Min.	Typ.	Max.	Unit
Transition frequency $V_{CE} = 10\text{ V}, I_C = 14\text{ mA}, f = 500\text{ MHz}$	f_T		5		GHz
Collector-emitter capacitance $V_{CE} = 10\text{ V}, f = 1\text{ MHz}$	C_{ce}		0.15		pF
Collector-base capacitance $V_{CB} = 10\text{ V}, f = 1\text{ MHz}$	C_{cb}		0.4		pF
Emitter-base capacitance $V_{EB} = 0.5\text{ V}, f = 1\text{ MHz}$	C_{eb}		1.3		pF
Noise figure $V_{CE} = 10\text{ V}, I_C = 2\text{ mA}, Z_S = 50\ \Omega, f = 500\text{ MHz}$	F		2.2		dB
Power gain $V_{CE} = 10\text{ V}, I_C = 14\text{ mA}, Z_L = Z_{Lopt},$ $f = 500\text{ MHz}$ $f = 800\text{ MHz}$	G_{pe} G_{pe}		19.5 14		dB dB
Linear output voltage – two tone intermodulation test $V_{CE} = 10\text{ V}, I_C = 14\text{ mA}, d_{IM} = 60\text{ dB},$ $f_1 = 806\text{ MHz}, f_2 = 810\text{ MHz}, Z_S = Z_L = 50\ \Omega$	$V_1 = V_2$		110		mV
Third order intercept point $V_{CE} = 10\text{ V}, I_C = 14\text{ mA}, f = 800\text{ MHz}$	IP_3		23.5		dBm

Common Emitter S-Parameters

$Z_0 = 50 \Omega$

V_{CE}/V	I_C/mA	f/MHz	S_{11}		S_{21}		S_{12}		S_{22}	
			LIN MAG	ANG	LIN MAG	ANG	LIN MAG	ANG	LIN MAG	ANG
				deg		deg		deg		deg
5	2	100	0.874	-27.5	6.36	158.2	0.032	74.7	0.959	-9.9
		300	0.668	-74.2	4.86	125.0	0.073	54.4	0.793	-21.4
		500	0.501	-107.9	3.59	104.4	0.089	47.0	0.677	-24.1
		800	0.385	-143.1	2.48	86.2	0.103	47.5	0.612	-24.5
		1000	0.361	-160.4	2.08	77.5	0.113	50.4	0.602	-25.9
		1200	0.351	-175.7	1.81	69.4	0.124	53.6	0.596	-28.7
		1500	0.371	164.7	1.52	59.0	0.145	58.1	0.581	-33.8
		1800	0.386	146.8	1.32	50.2	0.170	61.6	0.569	-38.6
	2000	0.407	136.8	1.23	45.1	0.192	62.9	0.564	-42.1	
	5	100	0.727	-41.3	12.49	147.4	0.028	69.6	0.891	-16.3
		300	0.457	-97.0	7.47	111.5	0.056	56.7	0.632	-25.5
		500	0.338	-131.5	4.94	95.1	0.073	57.6	0.532	-23.8
		800	0.276	-164.9	3.24	80.7	0.099	61.4	0.498	-21.3
		1000	0.268	-179.7	2.66	73.6	0.117	63.1	0.500	-22.4
		1200	0.272	168.1	2.29	67.0	0.137	63.9	0.499	-25.2
		1500	0.299	153.6	1.90	57.8	0.167	64.0	0.486	-30.3
		1800	0.324	138.7	1.64	50.0	0.199	63.5	0.476	-34.7
	2000	0.345	130.8	1.52	45.1	0.221	62.6	0.473	-38.1	
	10	100	0.566	-56.6	18.29	136.5	0.024	67.9	0.796	-21.6
		300	0.325	-116.5	8.85	103.0	0.048	63.4	0.526	-25.2
		500	0.263	-149.8	5.61	89.8	0.069	66.1	0.455	-21.2
		800	0.233	179.9	3.61	77.7	0.101	68.2	0.441	-17.7
		1000	0.229	167.5	2.95	71.4	0.123	68.1	0.449	-19.1
		1200	0.236	158.6	2.53	65.4	0.146	67.5	0.453	-22.4
		1500	0.271	147.4	2.08	57.0	0.179	65.9	0.440	-27.7
		1800	0.294	133.6	1.80	49.6	0.213	64.0	0.430	-32.0
	2000	0.318	126.8	1.66	44.7	0.235	62.3	0.427	-35.5	
	14	100	0.487	-65.1	20.67	131.1	0.022	67.4	0.745	-23.5
300		0.286	-125.4	9.25	100.0	0.046	66.3	0.491	-24.2	
500		0.243	-156.9	5.79	87.9	0.068	69.3	0.433	-19.6	
800		0.223	174.5	3.71	76.6	0.102	70.2	0.427	-16.2	
1000		0.223	163.2	3.02	70.5	0.125	69.6	0.436	-17.7	
1200		0.230	155.2	2.59	64.7	0.148	68.4	0.440	-21.2	
1500		0.262	145.1	2.13	56.6	0.182	66.5	0.427	-26.6	
1800		0.290	132.4	1.83	49.1	0.216	64.1	0.417	-30.9	
2000	0.313	124.8	1.69	44.6	0.239	62.3	0.413	-34.5		
20	100	0.409	-74.8	22.66	125.6	0.020	67.2	0.690	-24.7	
	300	0.257	-135.4	9.45	97.1	0.044	69.7	0.463	-22.2	
	500	0.232	-165.7	5.87	86.2	0.068	72.0	0.417	-17.4	
	800	0.224	169.2	3.74	75.4	0.103	71.7	0.418	-14.6	
	1000	0.223	159.7	3.05	69.5	0.127	70.8	0.430	-16.4	
	1200	0.233	153.2	2.61	63.9	0.150	69.1	0.433	-20.1	
	1500	0.265	143.6	2.15	55.9	0.184	66.9	0.421	-25.7	
	1800	0.292	131.8	1.84	48.7	0.217	64.3	0.411	-29.9	
2000	0.315	124.3	1.70	44.0	0.241	62.3	0.407	-33.6		

Common Emitter S-Parameters

$Z_0 = 50 \Omega$

V_{CE}/V	I_C/mA	f/MHz	S_{11}		S_{21}		S_{12}		S_{22}		
			LIN MAG	ANG	LIN MAG	ANG	LIN MAG	ANG	LIN MAG	ANG	
				deg		deg		deg		deg	
10	2	100	0.886	-25.8	6.37	159.2	0.026	75.9	0.967	-8.2	
		300	0.683	-69.8	4.96	127.0	0.061	56.4	0.827	-17.8	
		500	0.502	-102.2	3.70	106.5	0.076	49.6	0.726	-20.1	
		800	0.372	-137.0	2.57	88.2	0.088	50.2	0.671	-20.9	
		1000	0.339	-155.2	2.15	79.6	0.097	53.7	0.662	-22.2	
		1200	0.329	-171.2	1.87	71.8	0.107	56.9	0.660	-24.6	
		1500	0.343	167.4	1.57	61.3	0.126	62.0	0.648	-29.1	
		1800	0.359	148.5	1.35	52.7	0.149	65.9	0.639	-33.2	
	2000	0.372	137.6	1.25	47.5	0.168	67.7	0.638	-36.3		
	5	100	0.761	-37.4	12.28	149.3	0.024	71.1	0.914	-13.0	
		300	0.476	-89.1	7.63	113.9	0.048	58.3	0.693	-20.8	
		500	0.331	-122.2	5.11	96.9	0.063	58.9	0.606	-19.7	
		800	0.250	-156.3	3.35	82.5	0.086	62.8	0.576	-18.0	
		1000	0.237	-173.2	2.75	75.4	0.102	64.9	0.579	-19.2	
		1200	0.239	173.8	2.36	68.9	0.119	66.1	0.580	-21.8	
		1500	0.262	156.6	1.96	60.0	0.145	66.9	0.569	-26.1	
		1800	0.285	139.9	1.69	51.9	0.173	67.1	0.563	-30.2	
	2000	0.305	130.4	1.56	47.1	0.193	66.7	0.562	-33.3		
	10	10	100	0.619	-50.2	18.10	138.8	0.021	68.8	0.837	-17.2
			300	0.335	-105.0	9.10	105.0	0.042	64.0	0.603	-20.1
			500	0.242	-138.1	5.80	91.4	0.060	66.7	0.541	-17.1
			800	0.195	-172.5	3.73	79.1	0.088	69.0	0.529	-15.3
			1000	0.191	173.8	3.04	73.0	0.107	69.5	0.538	-16.7
			1200	0.196	163.2	2.60	67.2	0.127	69.3	0.543	-19.7
			1500	0.226	150.4	2.15	58.8	0.155	68.5	0.533	-24.3
			1800	0.255	134.3	1.85	51.4	0.184	67.3	0.526	-28.1
	2000	0.273	126.4	1.70	46.7	0.205	66.2	0.526	-31.2		
	14	14	100	0.548	-56.8	20.43	133.7	0.020	67.8	0.796	-18.5
300			0.289	-111.7	9.46	101.7	0.040	66.5	0.576	-19.0	
500			0.215	-145.8	5.95	89.3	0.059	69.3	0.524	-15.8	
800			0.179	-178.4	3.81	77.8	0.089	71.1	0.519	-14.1	
1000			0.180	168.9	3.10	72.0	0.108	70.8	0.530	-15.6	
1200			0.188	159.2	2.65	66.2	0.128	70.2	0.534	-18.7	
1500			0.223	148.0	2.19	58.2	0.158	68.9	0.526	-23.5	
1800			0.247	132.8	1.88	50.9	0.187	67.4	0.519	-27.4	
2000	0.268	125.7	1.73	46.4	0.208	66.1	0.518	-30.5			
20	20	100	0.482	-64.4	22.24	128.1	0.018	67.5	0.754	-19.0	
		300	0.253	-119.6	9.56	98.8	0.038	69.0	0.557	-17.0	
		500	0.202	-153.7	5.96	87.3	0.059	71.7	0.519	-14.0	
		800	0.180	176.6	3.79	76.5	0.089	72.5	0.521	-12.9	
		1000	0.179	163.4	3.08	70.7	0.109	71.8	0.532	-14.9	
		1200	0.188	156.0	2.63	65.3	0.129	70.9	0.536	-18.0	
		1500	0.220	146.1	2.17	57.5	0.159	69.5	0.527	-22.8	
		1800	0.250	131.5	1.86	50.2	0.187	67.8	0.520	-26.9	
2000	0.276	124.2	1.71	45.7	0.208	66.3	0.520	-30.1			

Dimensions of BFR92 in mm

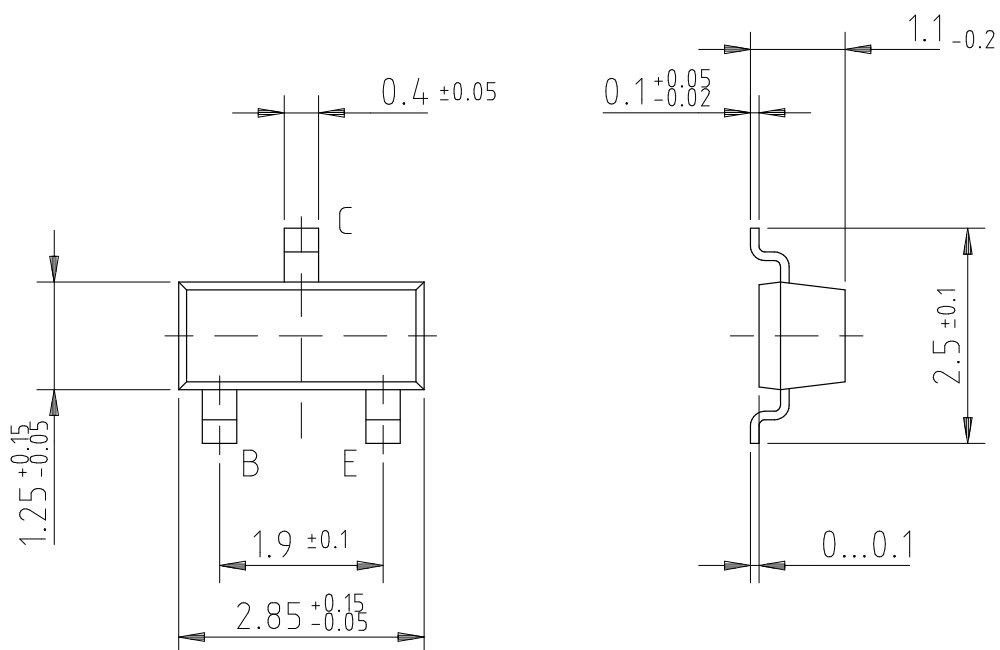

95 11346

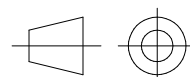

technical drawings
according to DIN
specifications

Dimensions of BFR92R in mm

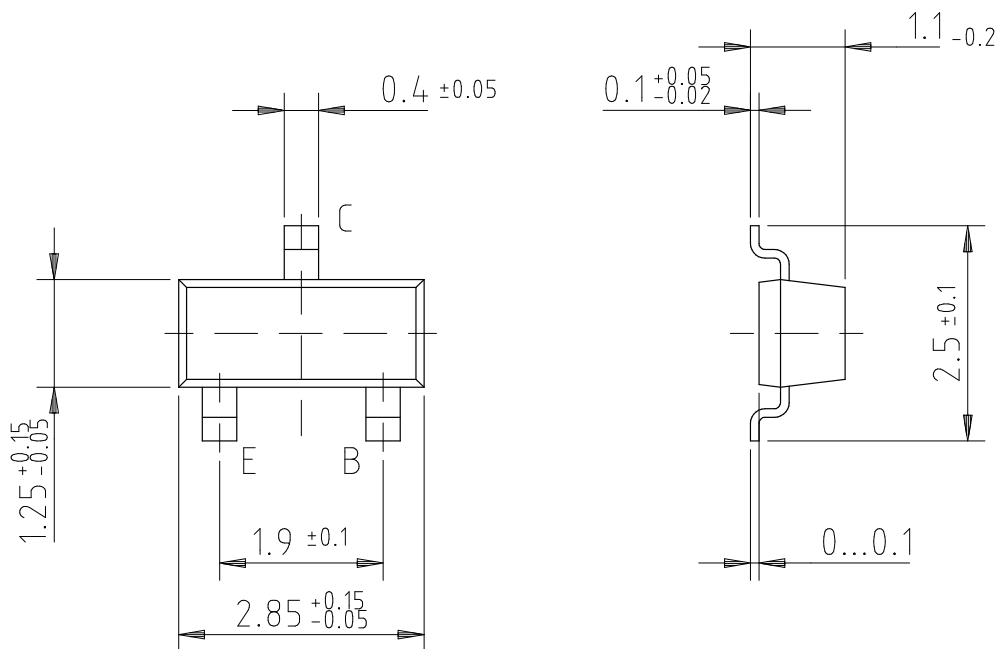

95 11347

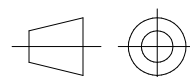

technical drawings
according to DIN
specifications

Ozone Depleting Substances Policy Statement

It is the policy of **TEMIC TELEFUNKEN microelectronic GmbH** to

1. Meet all present and future national and international statutory requirements.
2. Regularly and continuously improve the performance of our products, processes, distribution and operating systems with respect to their impact on the health and safety of our employees and the public, as well as their impact on the environment.

It is particular concern to control or eliminate releases of those substances into the atmosphere which are known as ozone depleting substances (ODSs).

The Montreal Protocol (1987) and its London Amendments (1990) intend to severely restrict the use of ODSs and forbid their use within the next ten years. Various national and international initiatives are pressing for an earlier ban on these substances.

TEMIC TELEFUNKEN microelectronic GmbH semiconductor division has been able to use its policy of continuous improvements to eliminate the use of ODSs listed in the following documents.

1. Annex A, B and list of transitional substances of the Montreal Protocol and the London Amendments respectively
2. Class I and II ozone depleting substances in the Clean Air Act Amendments of 1990 by the Environmental Protection Agency (EPA) in the USA
3. Council Decision 88/540/EEC and 91/690/EEC Annex A, B and C (transitional substances) respectively.

TEMIC can certify that our semiconductors are not manufactured with ozone depleting substances and do not contain such substances.

We reserve the right to make changes to improve technical design and may do so without further notice.

Parameters can vary in different applications. All operating parameters must be validated for each customer application by the customer. Should the buyer use TEMIC products for any unintended or unauthorized application, the buyer shall indemnify TEMIC against all claims, costs, damages, and expenses, arising out of, directly or indirectly, any claim of personal damage, injury or death associated with such unintended or unauthorized use.

TEMIC TELEFUNKEN microelectronic GmbH, P.O.B. 3535, D-74025 Heilbronn, Germany
Telephone: 49 (0)7131 67 2831, Fax number: 49 (0)7131 67 2423