

3-phase motor driver for VCR cylinder motors

BA6464FP-Y

The BA6464FP-Y is a 3-phase motor driver designed for VCR cylinder motors. It contains a power supply with a constant voltage of 5V, a short brake circuit, and a start/stop pin to open the output pins.

●Applications

VCR cylinder motors

●Features

- 1) 3-phase, full-wave, pseudo-linear drive system.
- 2) Internal constant voltage power supply. (5V)
- 3) Short brake circuit.
- 4) Internal thermal shutdown circuit.

●Absolute maximum ratings (Ta=25°C)

Parameter	Symbol	Limits	Unit
Applied voltage	V _{CC}	24	V
Power dissipation	P _d	1450* ¹	mW
Operating temperature	T _{opr}	-20~75	°C
Storage temperature	T _{stg}	-55~150	°C
Output current	I _{out}	1000* ²	mA

*1 Mounted on a glass epoxy PCB (90 X 50 X 1.6 mm).
Reduce power by 11.6 mW for each degree above 25 °C.

*2 Should not exceed P_d- or ASO-value.

●Recommended operating conditions (Ta=25°C)

Parameter	Symbol	Limits	Unit
Operating power supply voltage	V _{CC}	7.5~20.0	V

●Block diagram

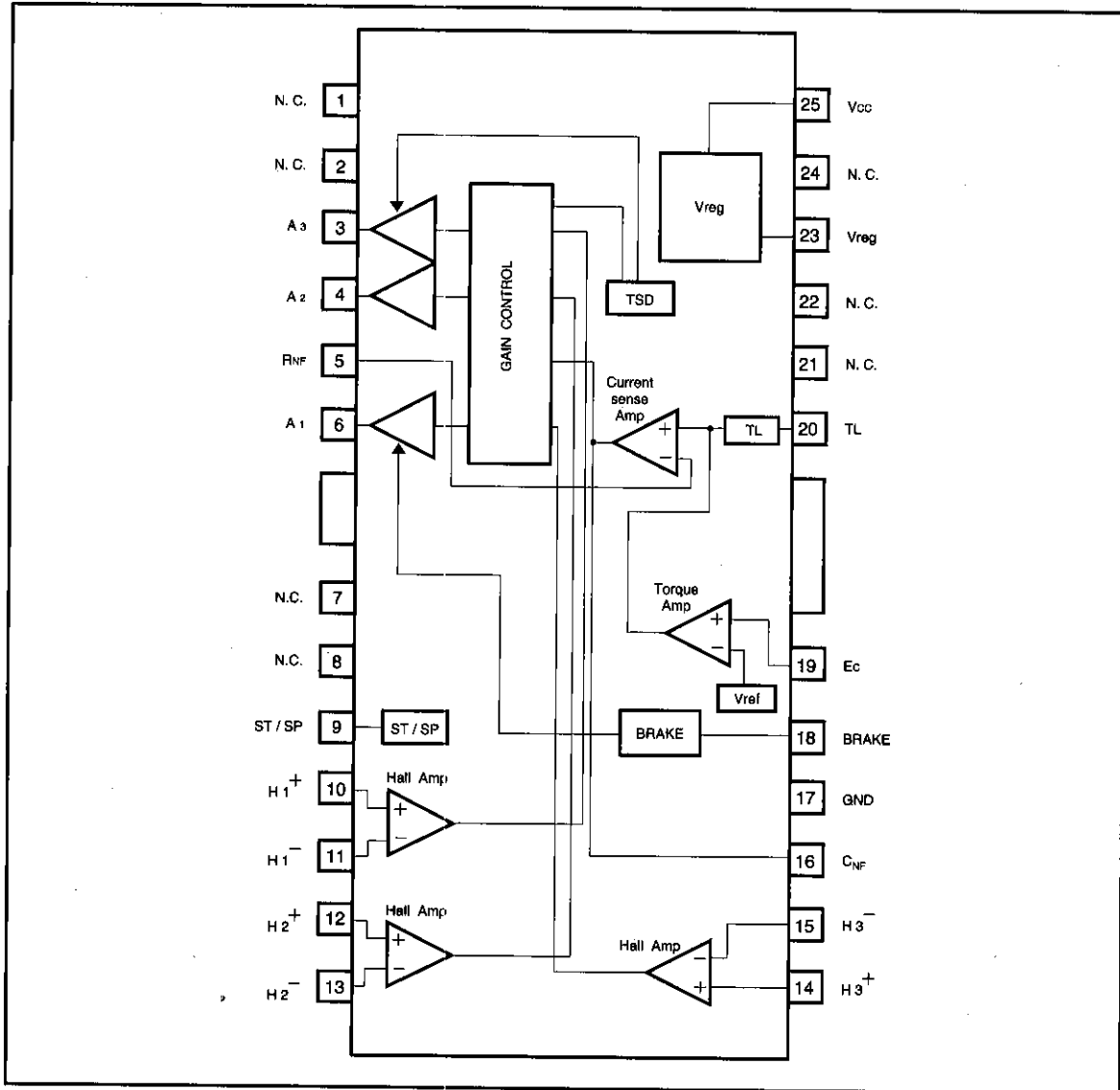

● Pin descriptions

Pin No.	Pin name	Function
1	N.C	Not used
2	N.C	Not used
3	A ₃	Output pin
4	A ₂	Output pin
5	R _{NF}	Output current sensing pin; normally a resistor (0.5 Ω is connected between this pin and the ground)
6	A ₁	Output pin
7	N.C	Not used
8	N.C	Not used
9	ST / SP	Start/stop switching pin; start mode when HIGH
10	H ₁ ⁺	Hall signal input pin
11	H ₁ ⁻	Hall signal input pin
12	H ₂ ⁺	Hall signal input pin
13	H ₂ ⁻	Hall signal input pin
14	H ₃ ⁺	Hall signal input pin
15	H ₃ ⁻	Hall signal input pin
16	C _{NF}	Capacitor connection pin for phase compensation; set the capacitor so that the output does not oscillate
17	GND	GND
18	BRAKE	BRAKE pin; connected to the E pin
19	E _c	Output current control pin; controls the motor current
20	TL	Torque limit pin; controls the motor current
21	N.C	Not used
22	N.C	Not used
23	V _{reg}	Internal constant voltage (5 V) output pin
24	N.C	Not used
25	V _{cc}	Power supply pin
FIN	FIN	Be sure to connect this fin to the ground

● Input/output circuits

Pin no.	Pin name	Pin description	I/O equivalent circuit
9	ST / SP	Start/stop switching pin	
20	TL	Torque limit pin	
19	Ec	Output current control pin	
3, 4, 6	A ₃ , A ₂ , A ₁	Output pin	
10, 11, 12, 13, 14, 15	H ₁ ⁺ , H ₁ ⁻ , H ₂ ⁺ H ₂ ⁻ , H ₃ ⁺ , H ₃ ⁻	Hall signal input pin	
18	BRAKE	Brake pin	

● Electrical characteristics (Unless otherwise noted, $T_a=25^\circ\text{C}$, $V_{CC}=12\text{V}$)

Parameter	Symbol	Min.	Typ.	Max.	Unit	Conditions
Circuit current	I_{CC}	—	6.0	11.0	mA	
Constant output voltage	V_{reg}	4.5	5.0	5.5	V	
~MDA~						
Hall input bias current	I_{HB}	—	0.25	5.0	μA	$H^+=\text{Hi}$, $H^-=\text{Low}$ or $H^+=\text{Low}$, $H^-=\text{Hi}$
Hall input common-mode voltage	V_{HB}	1.5	—	$V_{reg}-1.0$	V	
Hall device minimum input level	V_{INH}	60	—	—	mV _{P-P}	
Torque control input voltage	E_C	0	—	V_{reg}	V	
Torque control voltage offset	E_{offset}	-150	0	+150	mV	For $E_C = V_{reg} \times 0.46$
Output idle voltage	E_{idle}	—	0	10	mV	$E_C=2\text{V}$, $R_{NF}=0.5\ \Omega$
I/O gain	G_{EC}	0.5	0.6	0.7	A/V	Measured at $E_C = 2.8\text{V}$, 3.3V $R_{NF}=0.5\ \Omega$
Start/stop pin threshold voltage	$V_{S/S\ th}$	1.2	2.35	3.5	V	
HIGH level output saturation voltage	V_{OH}	—	1.05	1.75	V	$I_O=600\text{mA}$
LOW level output saturation voltage	V_{OL}	—	0.45	1.05	V	$I_O=600\text{mA}$
Output drive current capacity	$I_O(\text{Max.})$	800	—	—	mA	$R_{NF}=0.5\ \Omega$ $T_j=25^\circ\text{C}$ *
Torque limit current	I_{TL}	520	650	780	mA	$T_L=0.4\text{V}$, $R_{NF}=0.5\ \Omega$
~BRAKE~						
Brake pin threshold voltage	$V_{BRK\ th}$	1.5	1.6	1.7	V	When $V_{reg} = 5\text{V}$

* T_j is chip junction temperature.

© Not designed for radiation resistance.

● Circuit operation

(1) Hall I/O

The 3-phase Hall signal is amplified in the hall amplifiers and sent to the matrix section, where the signal is further amplified and combined. After the signal is converted to a current in the amplitude control circuit, the current is supplied to the output driver, which then provides a motor drive current. The phases of the Hall input signal, output voltage, and output current are shown in Fig. 1.

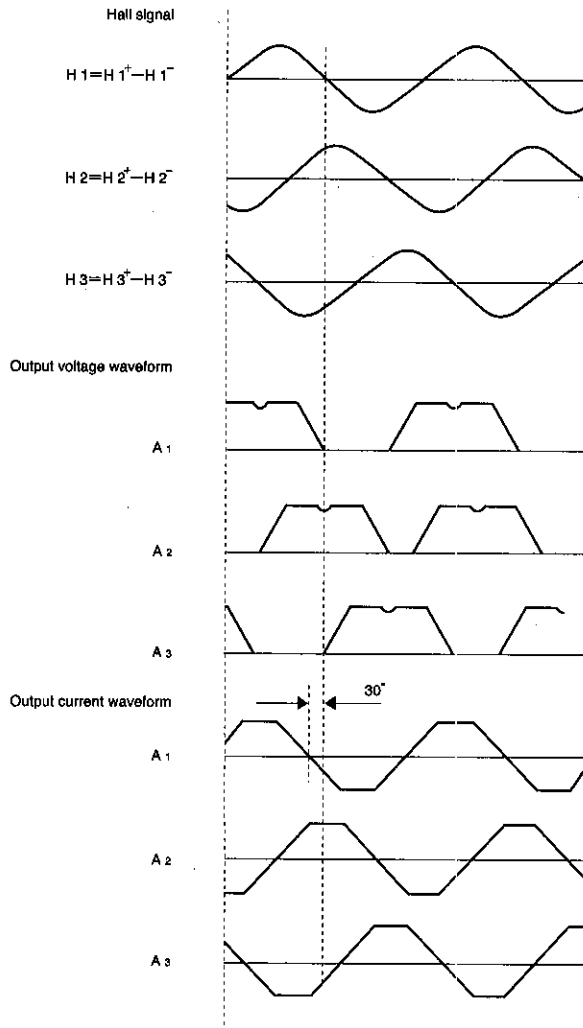

Fig.1

(2) Torque control pin (EC pin)

The output current can be controlled by adjusting the voltage applied to the torque control pin.

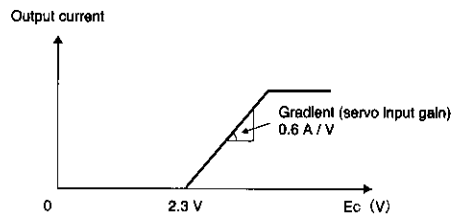

Fig.2

(3) Start/stop pin

The motor is in the run mode when the pin input voltage is 3.5V or more and in the idle mode (all output transistors are OFF) when the voltage is 1.2V or less.

(4) Power ground pin (RNF pin)

The RNF pin is the output stage ground pin. Connect a resistor (0.5Ω recommended) between this pin and the ground to monitor the output current.

(5) Phase compensation pin (CNF pin)

Connect a capacitor between this pin and V_{cc} if the output tends to oscillate.

(6) BRAKE pin (BRAKE)

Connect this pin to the torque control pin.

● Application example

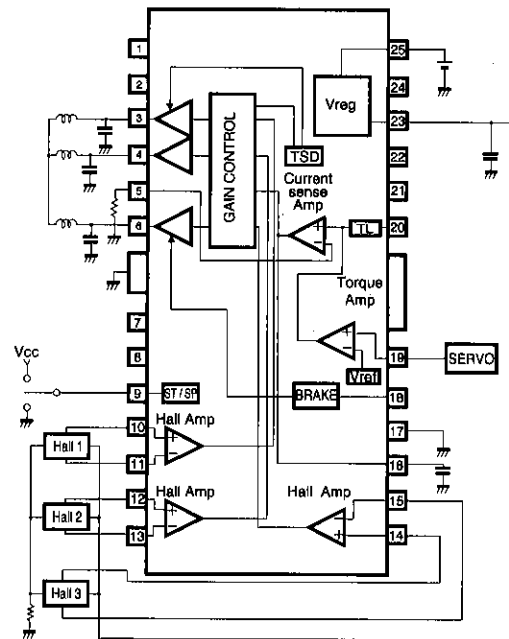

Fig.3

● Operation notes

(1) Start/stop pin

The I/O equivalent circuit of the start/stop pin is shown in Fig. 4. The pin has a temperature dependence of $-7\text{mV}/\text{C}$, and the resistance can vary $\pm 30\%$. The voltage on this pin should be less than V_{REG} .

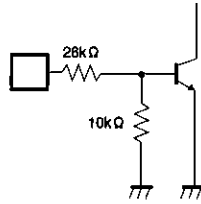

Fig.4

(2) Hall input

The I/O equivalent circuit of the Hall input pins is shown in Fig. 5. The Hall devices can be connected in either series or parallel. The input Hall signal should be within the range of the Hall input common-mode voltage.

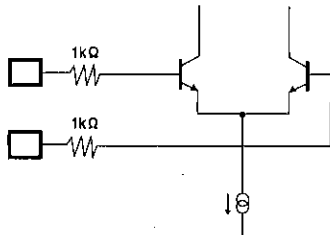

Fig.5

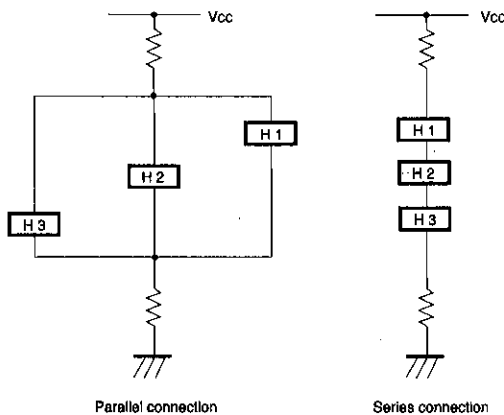

Fig.6

(3) Torque limit pin

The output current can be limited by applying a voltage to the torque limit pin. Control is provided so that this pin will have the same potential as the power ground pin (R_{NF}). Note that there is a voltage offset on this pin. The R_{NF} -pin voltage is 0.325V when the TL-pin voltage is 0.4V (typical) and the R_{NF} -pin resistance is $0.5\ \Omega$. Note that the voltage offset changes with the R_{NF} -pin resistance. Connect the TL pin to V_{REG} (pin 23) when the TL pin is not used.

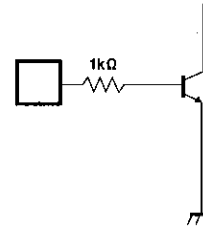

Fig.7

(4) Brake pin

Connect this pin to the EC pin. Do not use the brake pin in the open state.

(5) Thermal shutdown circuit

The circuit puts the driver outputs (A_1 , A_2 , and A_3) to the open state at the temperature of 175°C (typical). There is a temperature difference of about 20°C between the temperatures at which the circuit is activated and deactivated.

●Electrical characteristic curves

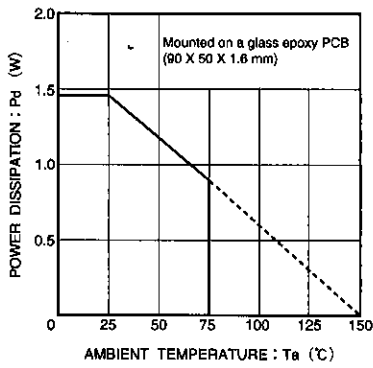

Fig.8 Power dissipation curves

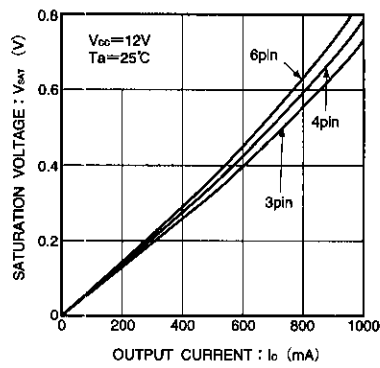

Fig.9 Low-side output saturation voltage vs. output current

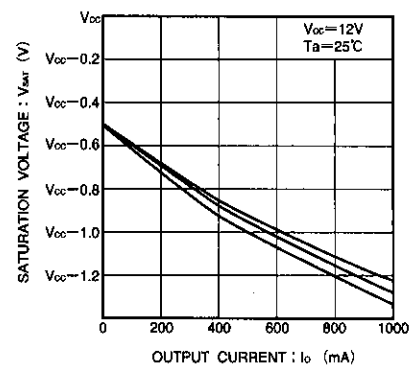
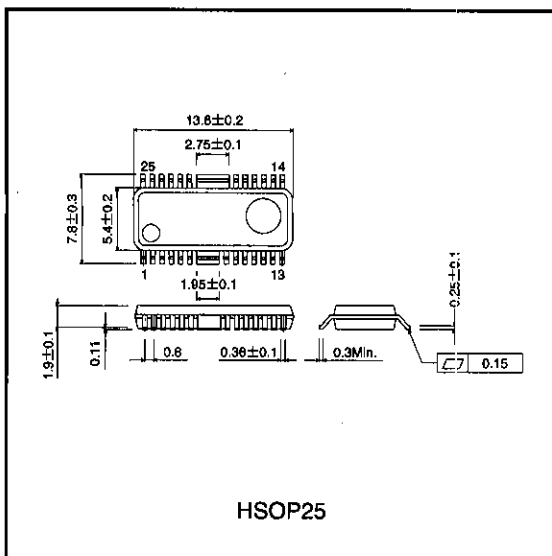

Fig.10 High-side output saturation voltage vs. output current

●External dimensions (Units: mm)



Notes

- The contents described in this catalogue are correct as of March 1997.
- No unauthorized transmission or reproduction of this book, either in whole or in part, is permitted.
- The contents of this book are subject to change without notice. Always verify before use that the contents are the latest specifications. If, by any chance, a defect should arise in the equipment as a result of use without verification of the specifications, ROHM CO., LTD., can bear no responsibility whatsoever.
- Application circuit diagrams and circuit constants contained in this data book are shown as examples of standard use and operation. When designing for mass production, please pay careful attention to peripheral conditions.
- Any and all data, including, but not limited to application circuit diagrams, information, and various data, described in this catalogue are intended only as illustrations of such devices and not as the specifications for such devices. ROHM CO., LTD., disclaims any warranty that any use of such device shall be free from infringement of any third party's intellectual property rights or other proprietary rights, and further, assumes absolutely no liability in the event of any such infringement, or arising from or connected with or related to the use of such devices.
- Upon the sale of any such devices; other than for the buyer's right to use such devices itself, resell or otherwise dispose of the same; no express or implied right or license to practice or commercially exploit any intellectual property rights or other proprietary rights owned or controlled by ROHM CO., LTD., is granted to any such buyer.
- The products in this manual are manufactured with silicon as the main material.
- The products in this manual are not of radiation resistant design.

The products listed in this catalogue are designed to be used with ordinary electronic equipment or devices (such as audio-visual equipment, office-automation equipment, communications devices, electrical appliances, and electronic toys). Should you intend to use these products with equipment or devices which require an extremely high level of reliability and the malfunction of which would directly endanger human life (such as medical instruments, transportation equipment, aerospace machinery, nuclear-reactor controllers, fuel controllers, or other safety devices) please be sure to consult with our sales representatives in advance.

- Notes when exporting
 - It is essential to obtain export permission when exporting any of the above products when it falls under the category of strategic material (or labor) as determined by foreign exchange or foreign trade control laws.
 - Please be sure to consult with our sales representatives to ascertain whether any product is classified as a strategic material.