

FG/CTL amplifier

BA6405F

The BA6405F is a dual channel signal amplifier with a built-in waveform shaping circuit. One channel consists of a limiter amplifier and a hysteresis comparator, and the other channel consists of an operational amplifier (only one pin is projected outside) and a comparator amplifier. The former channel is suited for CTL amplifiers in VCRs, and the latter channel is suited for FG amplifiers.

●Applications

VCRs, audio equipment

●Features

- 1) Built-in two operational amplifier circuits, one comparator circuit, and one hysteresis comparator circuit
- 2) High open-loop gain
- 3) Low noise level
- 4) Best suited for use as FG and CTL amplifiers in VCRs

●Absolute maximum ratings (Ta=25°C)

Parameter	Symbol	Limits	Unit
Power supply voltage	V _{cc}	12	V
Power dissipation	P _d	300 *	mW
Operating temperature	T _{opr}	-25~75	°C
Storage temperature	T _{stg}	-55~125	°C

* Reduce power by 3 mW for each degree above 25°C.

●Recommended operating conditions

Parameter	Symbol	Limits	Unit
Operating power supply voltage	V _{cc}	4.5~6.0	V

● Block diagram

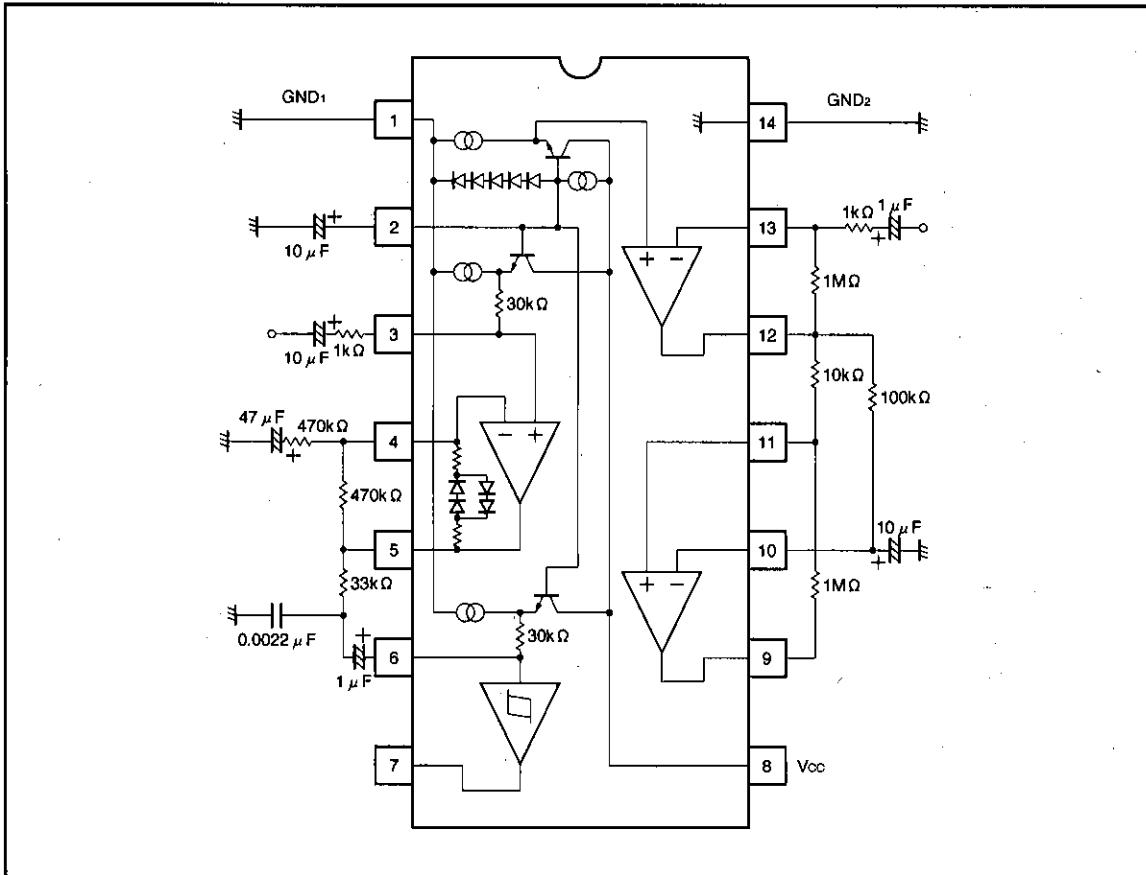

VCR components FG/CTL amplifiers

●Electrical characteristics (unless otherwise noted, Ta=25°C, Vcc=5.0 V)

Parameter	Symbol	Min.	Typ.	Max.	Unit	Conditions
Current consumption	I _{CC}	1.8	3.3	4.8	mA	—
CTL amplifier bias voltage	V _{B3}	2.1	2.45	2.8	V	3pin
CTL amplifier open loop gain	G _{VO CTL}	65	—	—	dB	3, 4, 5pin f=500Hz
CTL amplifier cut-off frequency	F _{C CTL}	500	—	—	Hz	3, 4, 5pin G _{vc} =60dB
CTL amplifier input bias current	I _{B4}	—	30	100	nA	4pin
CTL amplifier input conversion noise	N _{CTL}	—	1	6	μV _{rms}	3, 4, 5pin R _g =1kΩ DIN AUDIO
CTL amplifier maximum output voltage	V _{OM CTL}	2.5	3.3	—	V _{P-P}	5pin
FG amplifier input bias current	I _{B13}	—	50	250	nA	13pin, V _O =3.0V
FG amplifier input conversion noise	N _{FG}	—	1	6	μV _{rms}	12pin R _g =1kΩ DIN AUDIO
FG amplifier open loop gain	G _{VO FG}	65	—	—	dB	12, 13pin f=500Hz
FG amplifier cut-off frequency	F _{C FG}	500	—	—	Hz	12, 13pin G _{vc} =60dB
FG amplifier maximum output voltage	V _{OM FG}	2.5	3.4	—	V _{P-P}	12pin
Schmitt amplifier hysteresis	V _{hys}	±115	±150	±185	mV	6, 7pin
Schmitt amplifier LOW level output voltage	V _{OL7}	—	0.1	0.3	V	7pin I _{OL} =2mA
Comparator input offset voltage	V _{o11}	—6	0	6	mV	10, 11pin V _B =2.5V
Comparator input bias current 1	I _{B10}	—	50	250	nA	10pin V _C =2.0V, V _B =2.5V
Comparator input bias current 2	I _{B11}	—	50	250	nA	11pin V _C =3.0V, V _B =2.5V
Comparator LOW level output voltage	V _{OL9}	—	0.1	0.3	V	9pin I _{OL} =2mA
Pin-2 bias voltage	V _{B2}	2.7	3.05	3.4	V	2pin
Pin-7 pull-up resistance	R ₀₇	7	10	13	kΩ	7pin V _A =3.0V
Pin-9 pull-up resistance	R ₀₉	7	10	13	kΩ	9pin V _C =3.0V, V _B =2.5V

●Electrical characteristic curves

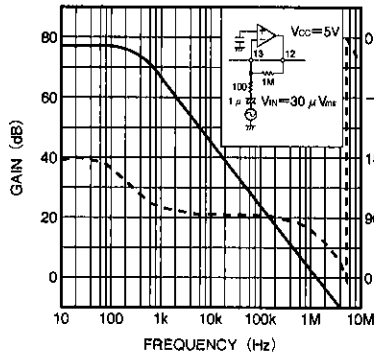

Fig. 1 FG amplifier frequency characteristics

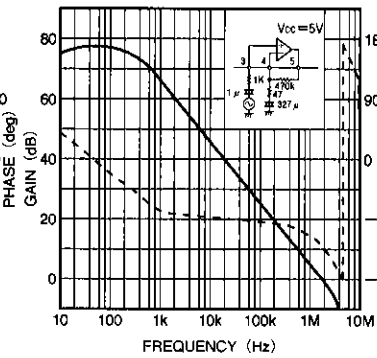

Fig. 2 CTL amplifier frequency characteristics

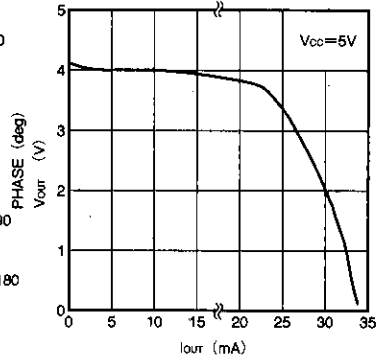

Fig. 3 CTL amplifier source current vs. output voltage

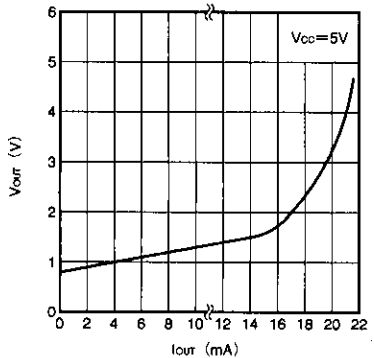

Fig. 4 CTL amplifier sink current vs. output voltage

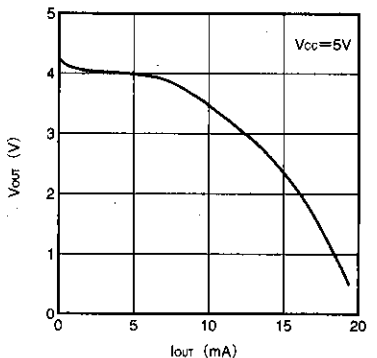

Fig. 5 FG amplifier source current vs. output voltage

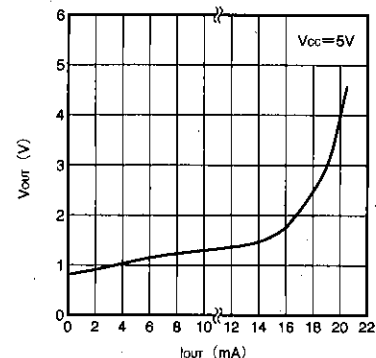

Fig. 6 FG amplifier sink current vs. output voltage

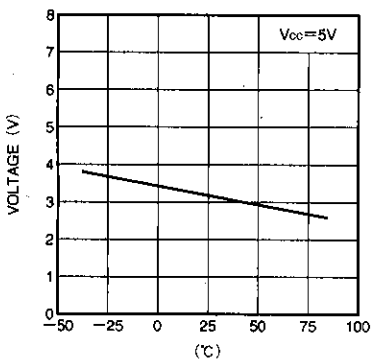

Fig. 7 Pin 2 DC bias voltage temperature characteristics

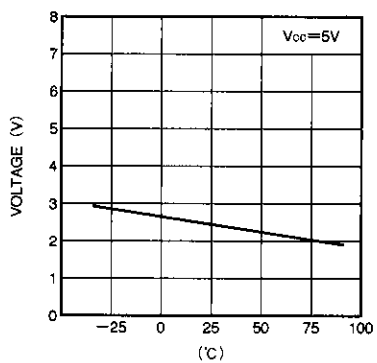

Fig. 8 Pin 3 bias voltage temperature characteristics

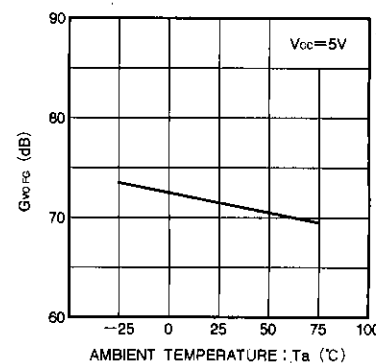

Fig. 9 FG amplifier gain temperature characteristics

FG/CTL amplifiers

VCR components

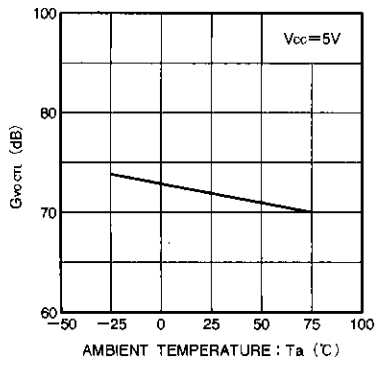
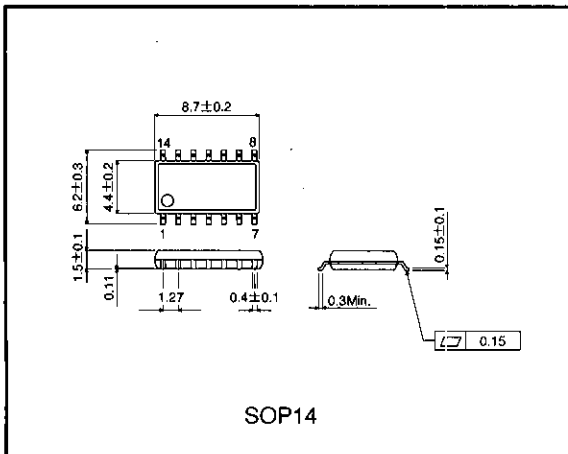

Fig. 10 CTL amplifier gain temperature characteristics

● External dimensions (Units: mm)



Notes

- The contents described in this catalogue are correct as of March 1997.
- No unauthorized transmission or reproduction of this book, either in whole or in part, is permitted.
- The contents of this book are subject to change without notice. Always verify before use that the contents are the latest specifications. If, by any chance, a defect should arise in the equipment as a result of use without verification of the specifications, ROHM CO., LTD., can bear no responsibility whatsoever.
- Application circuit diagrams and circuit constants contained in this data book are shown as examples of standard use and operation. When designing for mass production, please pay careful attention to peripheral conditions.
- Any and all data, including, but not limited to application circuit diagrams, information, and various data, described in this catalogue are intended only as illustrations of such devices and not as the specifications for such devices. ROHM CO., LTD., disclaims any warranty that any use of such device shall be free from infringement of any third party's intellectual property rights or other proprietary rights, and further, assumes absolutely no liability in the event of any such infringement, or arising from or connected with or related to the use of such devices.
- Upon the sale of any such devices; other than for the buyer's right to use such devices itself, resell or otherwise dispose of the same; no express or implied right or license to practice or commercially exploit any intellectual property rights or other proprietary rights owned or controlled by ROHM CO., LTD., is granted to any such buyer.
- The products in this manual are manufactured with silicon as the main material.
- The products in this manual are not of radiation resistant design.

The products listed in this catalogue are designed to be used with ordinary electronic equipment or devices (such as audio-visual equipment, office-automation equipment, communications devices, electrical appliances, and electronic toys). Should you intend to use these products with equipment or devices which require an extremely high level of reliability and the malfunction of which would directly endanger human life (such as medical instruments, transportation equipment, aerospace machinery, nuclear-reactor controllers, fuel controllers, or other safety devices) please be sure to consult with our sales representative in advance.

- Note when exporting
 - It is essential to obtain export permission when exporting any of the above products when it falls under the category of strategic material (or labor) as determined by foreign exchange or foreign trade control laws.
 - Please be sure to consult with our sales representatives to ascertain whether any product is classified as a strategic material.