

## Secret Tag on 80C51 Family Microcontrollers

### Overview

The Secret Tag is a feature which allows serialization of each microcontroller for identification of a specific equipment.

For instance, on a network, each terminal equipment can be identified by comparing the identifier sent via network with the identification number stored in the microcontroller.

One unique number per device is implemented. This serial number is a 64-bit binary value, which is contained and addressable in SFR (Special Function Registers) area.

This value can be used as an identification number, and

permits personalization of any electronic equipment using a 80C51 architecture.

The coding of the different registers allows TEMIC to guarantee that each value of the Secret Tag is UNIQUE.

For confidentiality on secret tag value, no special marking is written neither on the die nor on the final package. This value can be read out by classical instruction set routine. This routine is implemented inside the microcontroller ROM memory which can be kept secret (and then the value of the secret tag also) by using a ROM ENCRYPTION.

### Description

The secret tag register is composed of two groups of four consecutive bytes in the Special Function Register (SFR) area. One is placed at the FCh to FFh addresses and the other at the ECh to EFh addresses.

These registers are used as follows :

- Lot number (L0–L15) : number from 0 to 65535 referring to TEMIC fab lot number.
- Lot Number Extension (E0–E3) : <space> = 0  
A = 1  
O = 15

- Customized number (C0–C11) : fixed number from 0 to 4095 given by the customer.
- Year (Y0–Y3) : 1994 is 0, 1995 is 1, and so on.
- Month (M0–M3) : number from 1 to 12.
- Wafer Number (W0–W7) : number of Wafer.
- Serial Number (S0–S15) : number from 0 to 65535 incremented step by step.

	ADDRESS	b7	b6	b5	b4	b3	b2	b1	b0
TAG1	ECh	L7	L6	L5	L4	L3	L2	L1	L0
TAG2	EDh	L15	L14	L13	L12	L11	L10	L9	L8
TAG3	EEh	C3	C2	C1	C0	E3	E2	E1	E0
TAG4	EFh	C11	C10	C9	C8	C7	C6	C5	C4
TAG5	FCh	Y3	Y2	Y1	Y0	M3	M2	M1	M0
TAG6	FDh	W7	W6	W5	W4	W3	W2	W1	W0
TAG7	FEh	S7	S6	S5	S4	S3	S2	S1	S0
TAG8	FFh	S15	S14	S13	S12	S11	S10	S9	S8

**Secret Tag Example :**

TAG1	TAG2	TAG3	TAG4	TAG5	TAG6	TAG7	TAG8
01	04	02	00	18	0A	23	01

- Lot Number = 1025
- Lot Number Extension = 2
- Customized Number = 0
- Production Year = 1995 (1)
- Production Month = August (8)
- Serial Number = 291

**80C51 Routine to Read Out the Secret Tag**

The eight secret tag registers are mapped into 80C51 SFR area (Special Function Registers). The routine listed hereafter reads the Secret Tag Registers and sends it on the serial data link .

**Main\_Program:**

```

; ===== UART Initialization =====
  Mov    SCON,#53H ; 8-bit UART Variable/REN = 1
          ; TI / RI =1.
  Mov    TMOD,#20H ; 8-bit auto-reload mode for
          ; baud rate generator.
  Mov    TH1,#0E8H ; 1200bds at 11.059MHZ.
  Setb   TR1
  .
  .
  .
; Somewhere in the program the routine is
; called to transfer the Secret tag registers.
; Call   Secret_Tag_Transfer
  .
  .
; ===== Character Sending Routine =====
Send_Char:
  Jnb    TI,$      ; test if the transmitter is free to
          ; send a new character.
  Clr    TI
  Mov    SBUF,A    ; send the new character.
  Ret
; ===== Secret Tag Transfer Routine =====
Secret_Tag_Transfer:
  Mov    A,TAG1
  Call   Send_Char
  Mov    A,TAG2
  Call   Send_Char
  Mov    A,TAG3
  Call   Send_Char

```

```

Mov    A, TAG4
Call   Send_Char
Mov    A, TAG5
Call   Send_Char
Mov    A, TAG6
Call   Send_Char
Mov    A, TAG7
Call   Send_Char
Mov    A, TAG8
Call   Send_Char
Ret
    
```

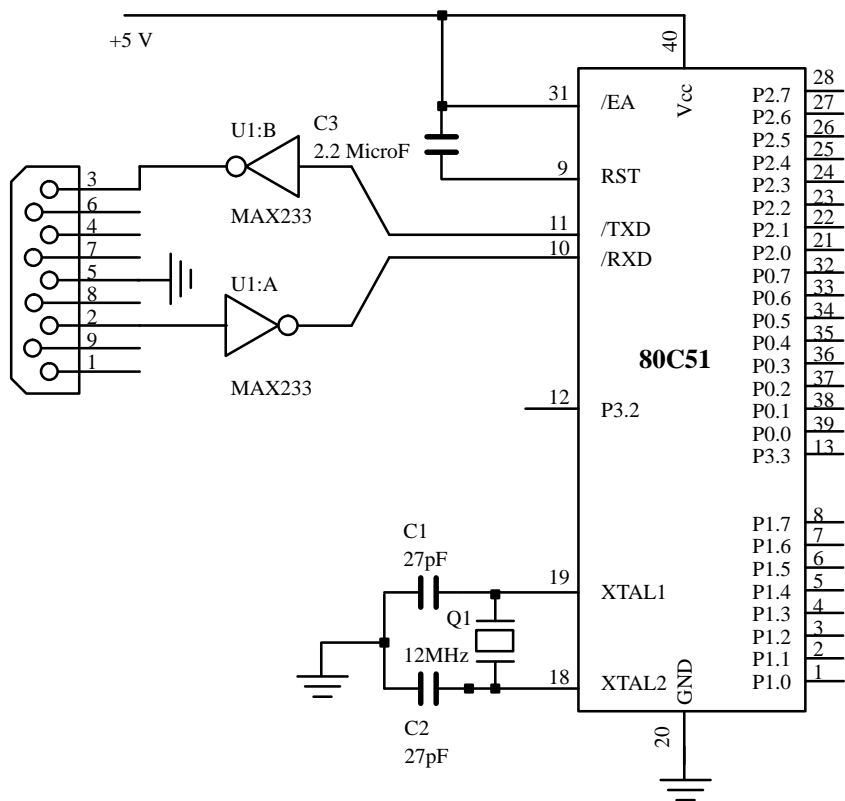

## Additional Information

For additional information on Microcontrollers, and Ordering Information, please refer to the product datasheets available upon request.