

Si9986CY Buffered H-Bridge

Robert P. Harshberger Jr.

Introduction

The Si9986CY is a buffered H-bridge that will eliminate all the external discretes that are normally needed to prevent shoot-through in low-voltage brushed motor, stepper motor, and actuator applications. Key features include the following:

- The output FETs are complementary, thus requiring no high-side drive power supply.
- Built-in shoot-through protection prevents both FETs on the same side of the H from being on at the same time. This protection ordinarily would require several external components or additional logic.
- The low-side sources are brought out separately for either single-ended or differential current sense.
- Operating range is 3.8 to 13.2 V, making the Si9986CY ideal for the common PC supply voltages of 5 and 12 V.
- Built-in logic provides four states controlled by CMOS level commands.
 - The two on-states where current flows through the load from either terminal (OUT_A to OUT_B or OUT_B to OUT_A).
 - A brake state where terminals OUT_A and OUT_B of the load are both connected to ground, resulting in a dynamic braking action.
 - A high impedance state where neither terminal OUT_A nor OUT_B of the load is connected, except through the internal flywheel diodes.
- The inputs may be switched at frequencies up to 200 kHz, allowing PWM operation.

- No additional components are necessary, except for a possible snubber circuit, depending on the load and electrical noise requirements and any feedback signal processors.

Applications

The examples and descriptions that follow refer to the truth table below for the Si9986CY.

Truth Table

State	IN _A	IN _B	OUT _A	OUT _B	Action
0	0	0	0	0	Brake
1	0	1	0	1	+Dir.
2	1	0	1	0	-Dir.
3	1	1	HiZ	HiZ	Open

Figure 1 shows a brushed dc motor operating in a full-on, bi-directional mode. Open loop control could be implemented by appropriate high-speed switching between states 1 and 2. (Refer to the Truth Table.)

Figure 2 shows a brushed dc motor operating in a controlled bi-directional, closed-loop mode. Speed control can be implemented by feeding back the low-pass filtered voltage at the load to control the duty cycle of the high-speed switching between states 1 and 2. (Refer to the Truth Table.)

Torque control can be accomplished by using the current feedback signal (Figure 3) to control the duty cycle of the high speed switching between states 1 or 2 and 3. (Refer to the Truth Table.)

Updates to this document may be obtained via facsimile by calling Siliconix FaxBack, 1-408-970-5600. Please request FaxBack document #8720.

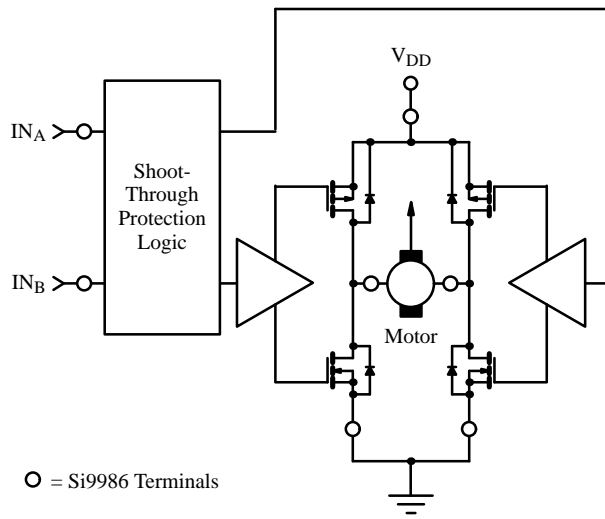
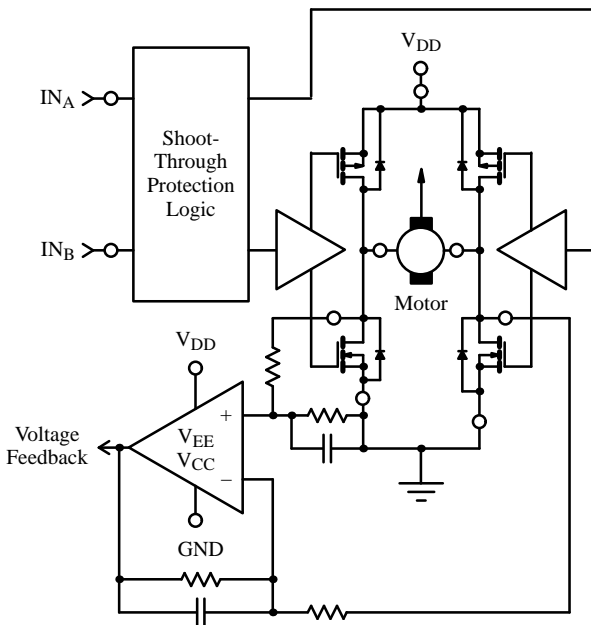
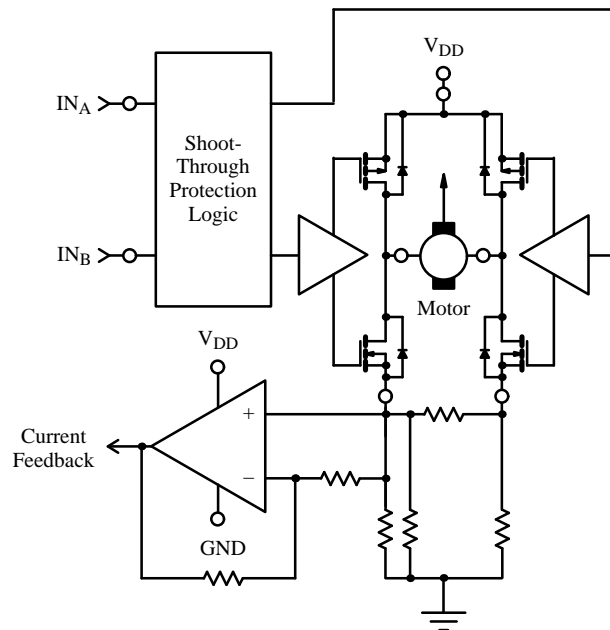

Figure 1. Basic Open Loop



○ = Si9986 Terminals

Figure 2. Voltage Feedback for PWM Motor Control



○ = Si9986 Terminals

Figure 3. Current Feedback for PWM Motor Control

Feedback Techniques

The Si9986CY uses pulse width modulation (PWM) for proportional control. Linear control requires additional external devices and will not be discussed here. The examples in Figure's 2 and 3 show how to obtain a voltage and a current signal for feedback purposes.

Voltage feedback is used where motor speed is the primary controlled variable. In this case, a low-pass filter is used since the voltage at the load is a high-frequency rectangular wave. The baseband component of this voltage is proportional to the duty cycle of the rectangular wave. The cut-off of the filter is chosen to stop the PWM frequency but pass the lower baseband frequencies required for feedback and control. The rectangular wave switches between the two active states 1 and 2. Switching between these output states tends to give greater control of the voltage and speed, since the output impedance is always low.

Current feedback is used where motor torque or acceleration is the primary controlled variable. A low-pass filter is normally not required, since the motor inductance acts as the filter. If the inductance or the PWM frequency is too low, a low-pass filter may be required. At the output, the rectangular wave switches between active states (1 or 2) and the high impedance state (3). This tends to give greater control of the torque and acceleration, because the output impedance is high when the PWM cycle is off. Motor braking during these periods is thus minimized.

With either feedback technique, state 0 (see Truth Table) will result in motor braking. The analog output of the voltage sense filter or current sense is fed back to the controller input to close the loop. This may be a discrete controller, a microcontroller, DSP, or fuzzy controller. The operation of the controller is beyond the scope of this application brief.