

HIGH SPEED SWITCHES

DESCRIPTION

The 2N2219A and 2N2222A are silicon planar epitaxial NPN transistors in Jedec TO-39 (for 2N2219A) and in Jedec TO-18 (for 2N2222A) metal case. They are designed for high speed switching application at collector current up to 500mA, and feature useful current gain over a wide range of collector current, low leakage currents and low saturation voltage.

☞ 2N2219A approved to CECC 50002-100,
2N2222A approved to CECC 50002-101
available on request.

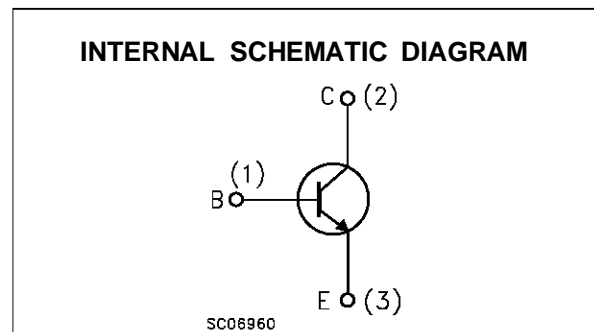
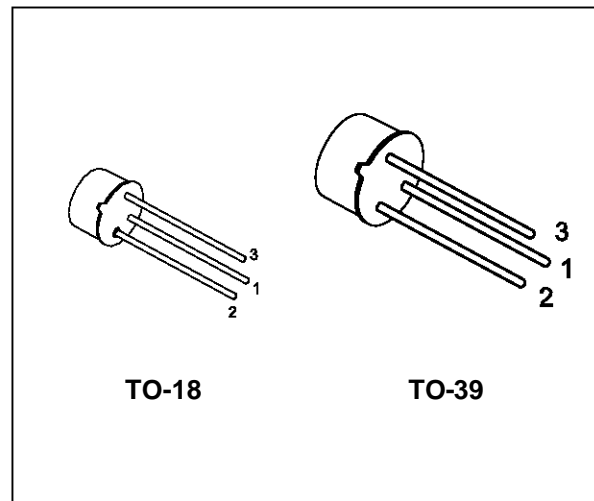

ABSOLUTE MAXIMUM RATINGS

Symbol	Parameter	Value	Unit
V_{CBO}	Collector-Base Voltage ($I_E = 0$)	75	V
V_{CEO}	Collector-Emitter Voltage ($I_B = 0$)	40	V
V_{EBO}	Emitter-Base Voltage ($I_C = 0$)	6	V
I_C	Collector Current	0.8	A
P_{tot}	Total Dissipation at $T_{amb} \leq 25\text{ }^\circ\text{C}$ for 2N2219A for 2N2222A at $T_{case} \leq 25\text{ }^\circ\text{C}$ for 2N2219A for 2N2222A	0.8	W
		0.5	W
		3	W
		1.8	W
T_{stg}	Storage Temperature	-65 to 200	$^\circ\text{C}$
T_j	Max. Operating Junction Temperature	175	$^\circ\text{C}$

2N2219A/2N2222A

THERMAL DATA

			TO-39	TO-18	
R _{thj-case}	Thermal Resistance Junction-Case	Max	50	83.3	°C/W
R _{thj-amb}	Thermal Resistance Junction-Ambient	Max	187.5	300	°C/W

ELECTRICAL CHARACTERISTICS (T_{case} = 25 °C unless otherwise specified)

Symbol	Parameter	Test Conditions	Min.	Typ.	Max.	Unit
I _{CBO}	Collector Cut-off Current (I _E = 0)	V _{CB} = 60 V V _{CB} = 60 V T _{case} = 150 °C			10 10	nA μA
I _{CEX}	Collector Cut-off Current (V _{BE} = -3V)	V _{CE} = 60 V			10	nA
I _{BEX}	Base Cut-off Current (V _{BE} = -3V)	V _{CE} = 60 V			20	nA
I _{EBO}	Emitter Cut-off Current (I _C = 0)	V _{EB} = 3 V			10	nA
V _{(BR)CBO} *	Collector-Base Breakdown Voltage (I _E = 0)	I _C = 10 μA	75			V
V _{(BR)CEO} *	Collector-Emitter Breakdown Voltage (I _B = 0)	I _C = 10 mA	40			V
V _{(BR)EBO} *	Emitter-Base Breakdown Voltage (I _C = 0)	I _E = 10 μA	6			V
V _{CE(sat)} *	Collector-Emitter Saturation Voltage	I _C = 150 mA I _B = 15 mA I _C = 500 mA I _B = 50 mA			0.3 1	V V
V _{BE(sat)} *	Base-Emitter Saturation Voltage	I _C = 150 mA I _B = 15 mA I _C = 500 mA I _B = 50 mA	0.6		1.2 2	V V
h _{FE} *	DC Current Gain	I _C = 0.1 mA V _{CE} = 10 V I _C = 1 mA V _{CE} = 10 V I _C = 10 mA V _{CE} = 10 V I _C = 150 mA V _{CE} = 10 V I _C = 500 mA V _{CE} = 10 V I _C = 150 mA V _{CE} = 1 V I _C = 10 mA V _{CE} = 10 V T _{amb} = -55 °C	35 50 75 100 40 50 35		300	
h _{fe} *	Small Signal Current Gain	I _C = 1 mA V _{CE} = 10 V f = 1KHz I _C = 10 mA V _{CE} = 10 V f = 1KHz	50 75		300 375	
f _T	Transition Frequency	I _C = 20 mA V _{CE} = 20 V f = 100 MHz	300			MHz
C _{EBO}	Emitter Base Capacitance	I _C = 0 V _{EB} = 0.5 V f = 100KHz			25	pF
C _{CBO}	Collector Base Capacitance	I _E = 0 V _{CB} = 10 V f = 100 KHz			8	pF
R _{e(hie)}	Real Part of Input Impedance	I _C = 20 mA V _{CE} = 20 V f = 300MHz			60	Ω

* Pulsed: Pulse duration = 300 μs, duty cycle ≤ 1 %

ELECTRICAL CHARACTERISTICS (continued)

Symbol	Parameter	Test Conditions	Min.	Typ.	Max.	Unit
NF	Noise Figure	$I_C = 0.1 \text{ mA}$ $V_{CE} = 10 \text{ V}$ $f = 1\text{KHz}$ $R_g = 1\text{K}\Omega$		4		dB
h_{ie}	Input Impedance	$I_C = 1 \text{ mA}$ $V_{CE} = 10 \text{ V}$ $I_C = 10 \text{ mA}$ $V_{CE} = 10 \text{ V}$	2 0.25		8 1.25	Ω Ω
h_{re}	Reverse Voltage Ratio	$I_C = 1 \text{ mA}$ $V_{CE} = 10 \text{ V}$ $I_C = 10 \text{ mA}$ $V_{CE} = 10 \text{ V}$			8 4	10^{-4} 10^{-4}
h_{oe}	Output Admittance	$I_C = 1 \text{ mA}$ $V_{CE} = 10 \text{ V}$ $I_C = 10 \text{ mA}$ $V_{CE} = 10 \text{ V}$	5 25		35 200	μS μS
t_d^{**}	Delay Time	$V_{CC} = 30 \text{ V}$ $I_C = 150 \text{ mA}$ $I_{B1} = 15 \text{ mA}$ $V_{BB} = -0.5 \text{ V}$			10	ns
t_r^{**}	Rise Time	$V_{CC} = 30 \text{ V}$ $I_C = 150 \text{ mA}$ $I_{B1} = 15 \text{ mA}$ $V_{BB} = -0.5 \text{ V}$			25	ns
t_s^{**}	Storage Time	$V_{CC} = 30 \text{ V}$ $I_C = 150 \text{ mA}$ $I_{B1} = -I_{B2} = 15 \text{ mA}$			225	ns
t_f^{**}	Fall Time	$V_{CC} = 30 \text{ V}$ $I_C = 150 \text{ mA}$ $I_{B1} = -I_{B2} = 15 \text{ mA}$			60	ns
$r_{bb'}$, $C_{b'c}$	Feedback Time Constant	$I_C = 20 \text{ mA}$ $V_{CE} = 20 \text{ V}$ $f = 31.8\text{MHz}$			150	ps

* Pulsed: Pulse duration = 300 μs , duty cycle $\leq 1\%$

** See test circuit

Normalized DC Current Gain.

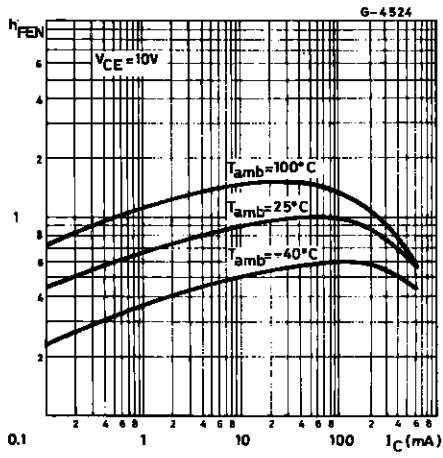

Collector-emitter Saturation Voltage.

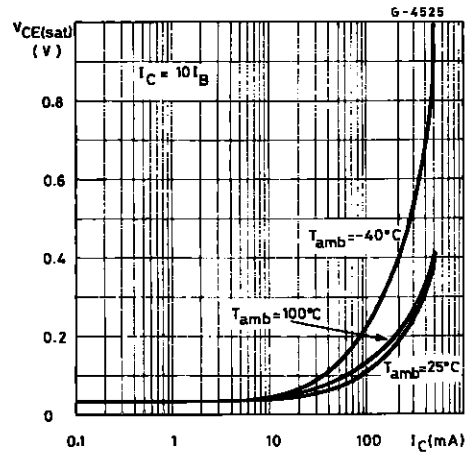

Contours of Constant Narrow Band Noise Figure.

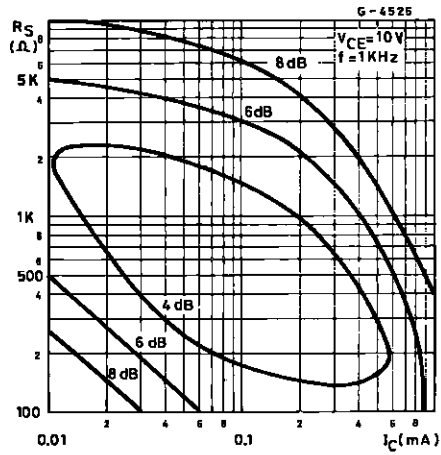

Switching Time vs. Collector Current.

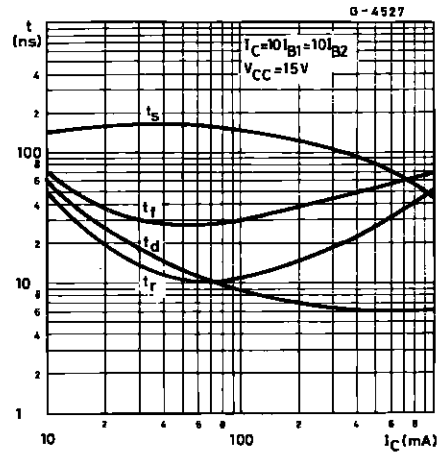

Test Circuit for t_d , t_r .

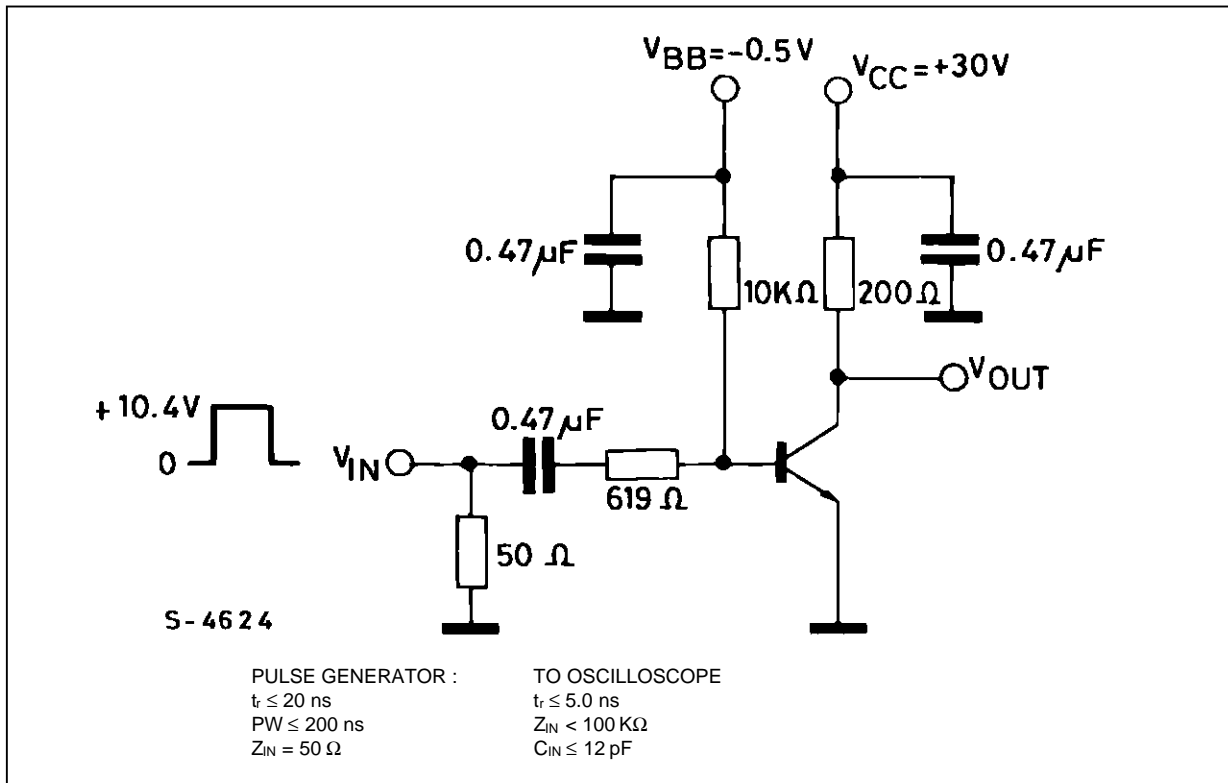

Test Circuit for t_d , t_r .

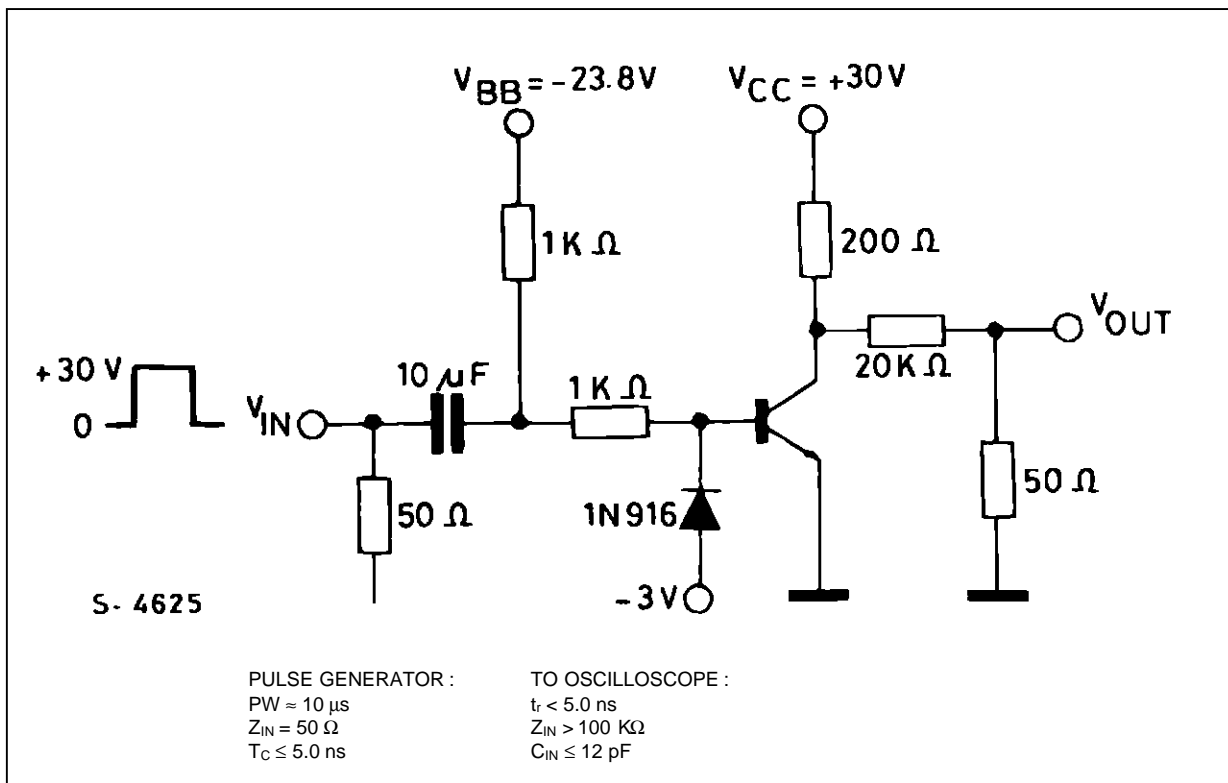

TO-18 MECHANICAL DATA

DIM.	mm			inch		
	MIN.	TYP.	MAX.	MIN.	TYP.	MAX.
A		12.7			0.500	
B			0.49			0.019
D			5.3			0.208
E			4.9			0.193
F			5.8			0.228
G	2.54			0.100		
H			1.2			0.047
I			1.16			0.045
L	45°			45°		

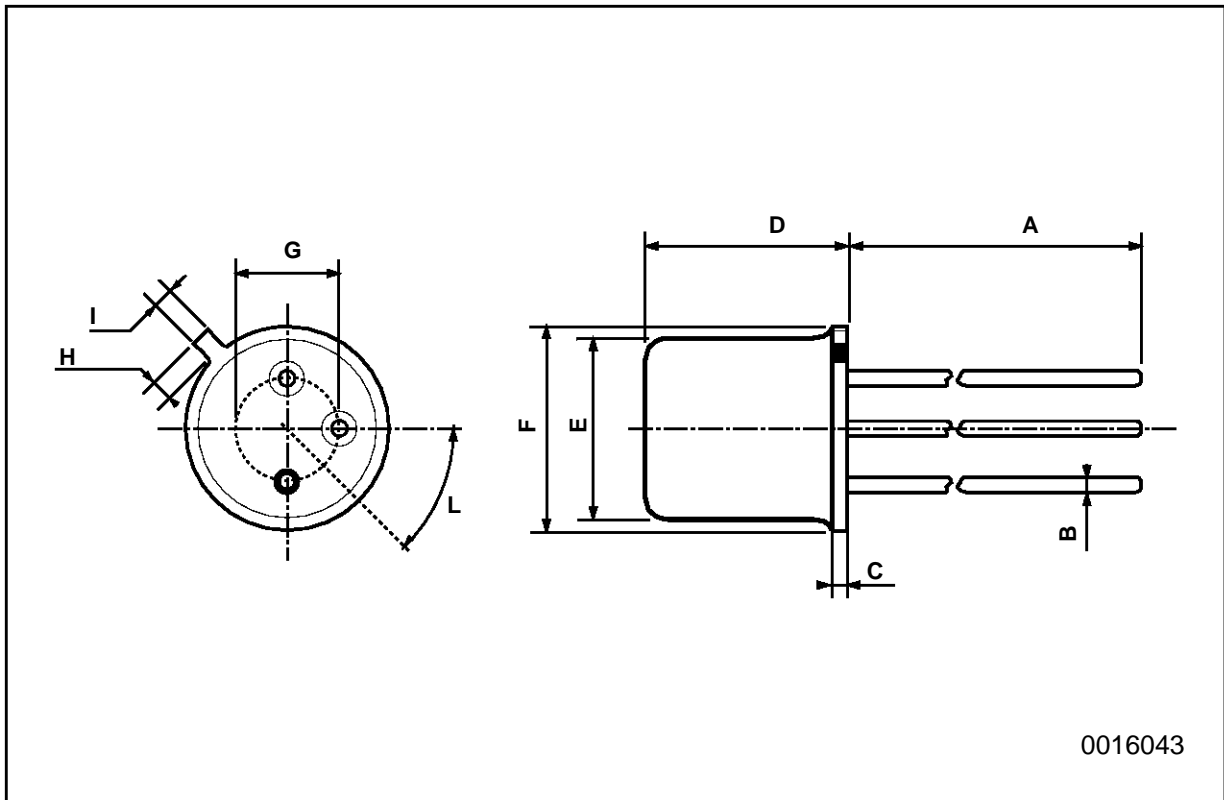

TO-39 MECHANICAL DATA

DIM.	mm			inch		
	MIN.	TYP.	MAX.	MIN.	TYP.	MAX.
A	12.7			0.500		
B			0.49			0.019
D			6.6			0.260
E			8.5			0.334
F			9.4			0.370
G	5.08			0.200		
H			1.2			0.047
I			0.9			0.035
L	45° (typ.)					

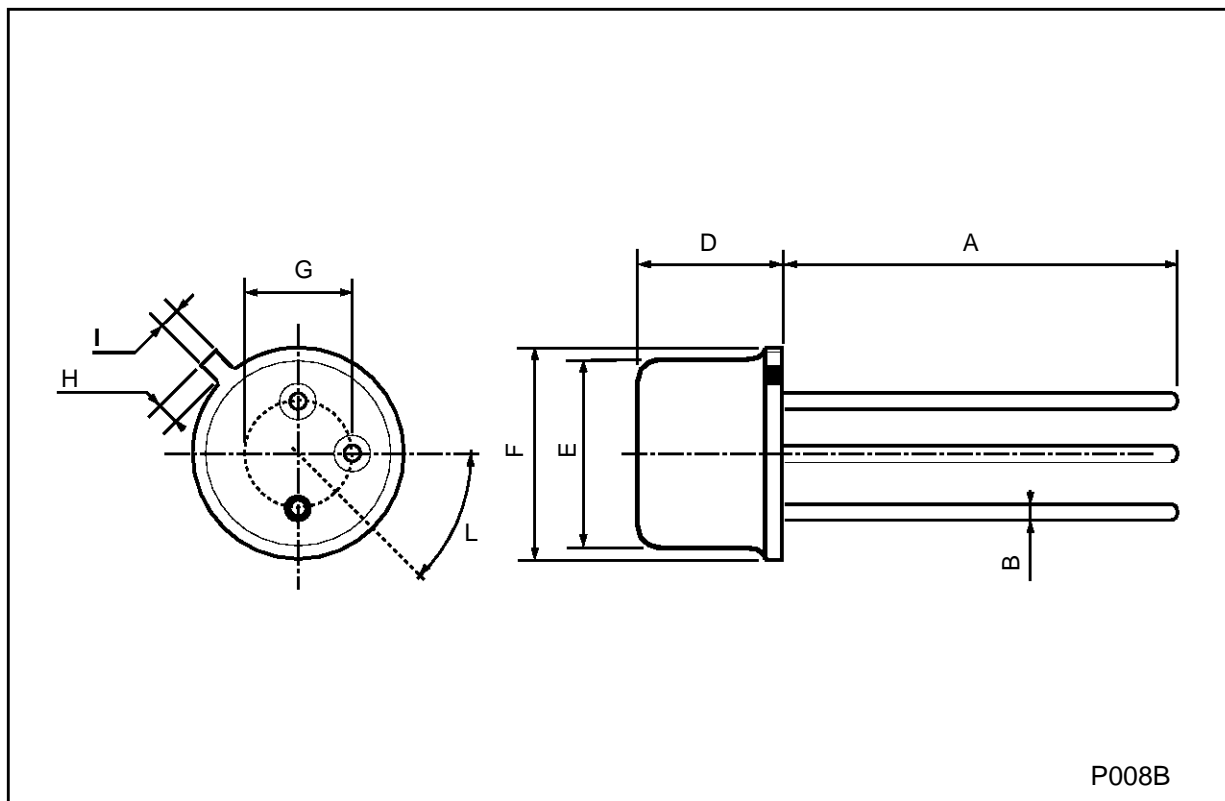

Information furnished is believed to be accurate and reliable. However, SGS-THOMSON Microelectronics assumes no responsibility for the consequences of use of such information nor for any infringement of patents or other rights of third parties which may result from its use. No license is granted by implication or otherwise under any patent or patent rights of SGS-THOMSON Microelectronics. Specifications mentioned in this publication are subject to change without notice. This publication supersedes and replaces all information previously supplied. SGS-THOMSON Microelectronics products are not authorized for use as critical components in life support devices or systems without express written approval of SGS-THOMSON Microelectronics.

© 1997 SGS-THOMSON Microelectronics - Printed in Italy - All Rights Reserved

SGS-THOMSON Microelectronics GROUP OF COMPANIES

Australia - Brazil - Canada - China - France - Germany - Italy - Japan - Korea - Malaysia - Malta - Morocco - The Netherlands -
Singapore - Spain - Sweden - Switzerland - Taiwan - Thailand - United Kingdom - U.S.A

...