

Switching regulators demystified

By Tom Mathews, principal engineer

You can see the proliferation of switching regulators throughout the electronics industry. These versatile devices can perform many functions, including voltage regulation, current regulation, or both. The fundamental theory behind the operation of the switching regulator is relatively simple. However, like any engineering endeavor, close attention to detail is important to avoid problems and poor performance. Key to good design of switching-regulator circuits is a solid understanding of the fundamental theory of operation.

Background

Like their venerable cousin the linear regulator, switching regulators can reduce and regulate an input voltage. Switching circuits of this type are called buck regulators. Unlike their linear equivalent, switching regulators have a key advantage because that efficiency is far better. Switching-regulator efficiencies can be as high as 97%. High efficiencies are particularly of value in battery-operated circuits. Furthermore, the increased efficiency of a switcher usually leads to significant reductions in unwanted heat dissipation. Many switching-power designs can eliminate a heat sink that the equivalent linear design would otherwise require.

Another feature of the switching regulator is its ability to step up (increase) dc voltages. This type is the boost regulator. You may also know the boost regulator as a dc/dc converter. Boost regulators (and buck regulators, as well) perform a function that is very similar to that performed by a transformer, only at dc. In fact, the voltages and currents at the input and output of a switcher behave in a way that is almost identical to the behavior of a transformer.

Other variations on switching-supply design include isolated output converters and buck and boost conversion. Isolation eliminates any connections between the input ground and the output ground and allows the output voltage to “float.” An isolated design usually incorporates a transformer to provide the isolation for the switching currents and an optical isolator to isolate the feedback-sensing voltage.

The buck/boost switcher is a special hybrid of both the buck and boost functions. This type of switcher can shift gears from buck to boost when its input voltage falls below the output voltage. This type of design is of particular value in battery-operated systems in which the battery voltage is expected to fall below the required regulator output voltage. Because of this ability, the buck/boost can continue to provide regulation as battery voltages drop below the output and hence can more fully drain a battery, resulting in an apparent increase of battery life.

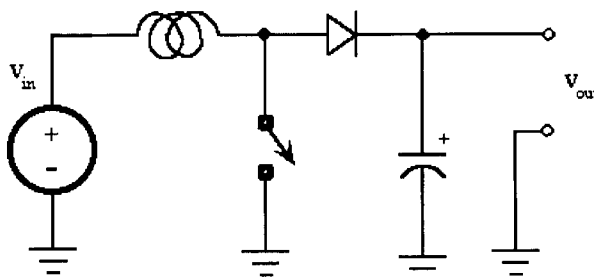

Figure 1 – Basic boost circuit

Magnetics

The magnetics provide the heart of any switching supply. Switching regulators use both solenoid-wound inductors and toroidal inductors that are usually wound on high-permeability cores. You also see transformers, especially in isolated designs. Because of their key role, inductors and their behavior warrant a simple review. Much like a capacitor, an inductor stores energy. A capacitor stores its energy in an electric field, and the inductor stores its energy in a magnetic field. This field builds up as current flows through the inductor and, once established, resists change. The inductor equation states that the voltage at the inductor's terminals is proportional to the rate of change (slope) in current through the inductor (di/dt). The constant of proportionality is the inductance (L):

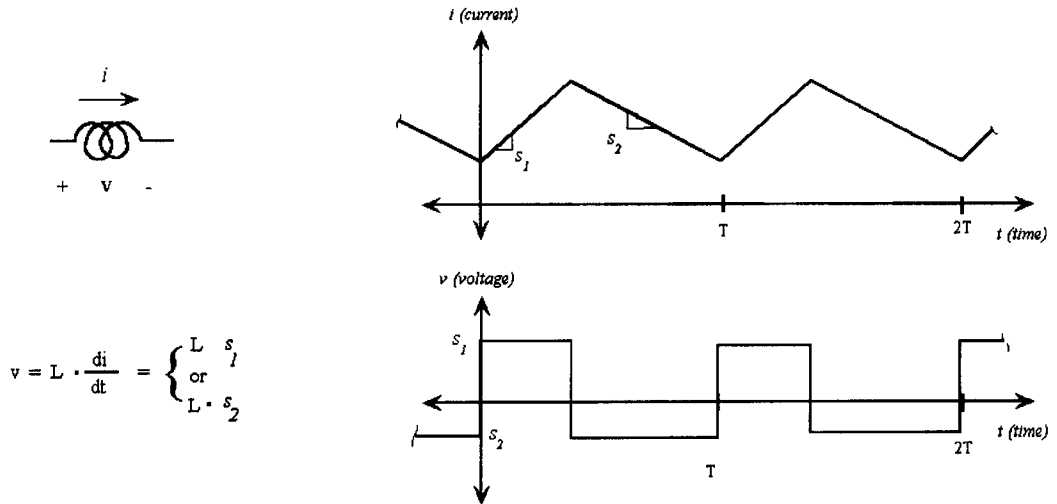

Figure 2 – Inductor behavior

Notice that if an instantaneous change in current were to occur, then an infinite voltage would result at the inductor terminals. Because nature dislikes infinite-voltage steps, the inductor does its best to resist any rapid changes in current. The switching-regulator design takes advantage of this fact. Controlled changes in inductor current create abrupt changes in voltage at the terminals of the inductor.

A mechanical analogy to this idea is momentum. The current through the inductor is much like a freight train; once the train is in motion, it wants to continue at its current speed and is difficult to stop. Similarly, the inductor does not allow abrupt changes in the current through its coils.

Freight-train analogy—the boost circuit

A simplified diagram of a boost switching regulator appears below. The diagram examines two phases of operation. The first phase, phase I, is the build-up of current in the inductor. This build-up occurs when the switch is closed and continues for a predetermined amount of time. Similarly, an unpowered train resting on a flat surface builds up speed as its front half rolls down a hill.

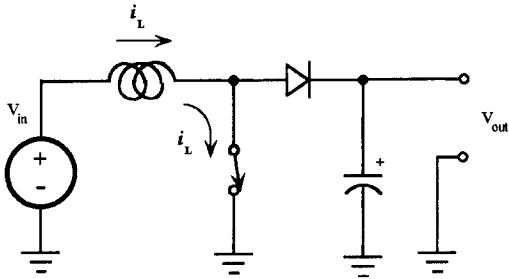

Phase I – Build up of inductor current.

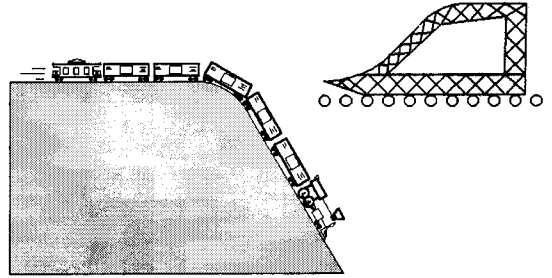

The train builds up momentum.

Once a current establishes in the inductor, the switch opens. Because the current through the inductor resists change, it must continue to flow. It has no choice but to flow through the diode and to the output. This change in current causes a step voltage to appear across the inductor. The current flows to a higher voltage at V_{out} .

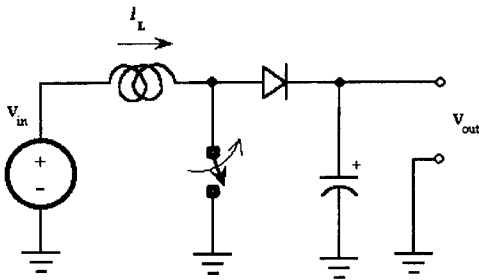

Start of phase II - The switch opens

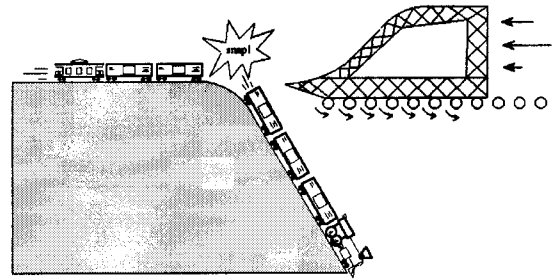

The train breaks in two, and the bridge moves into place.

Like the current in the inductor, the trailing cars of the freight train roll to a higher position (voltage) because of their momentum.

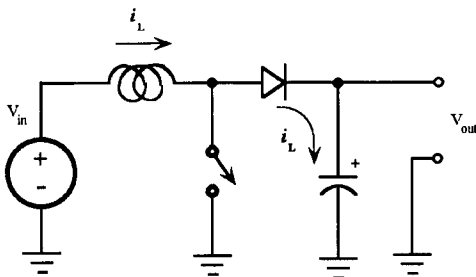

Phase II – Inductor current flows into the load.

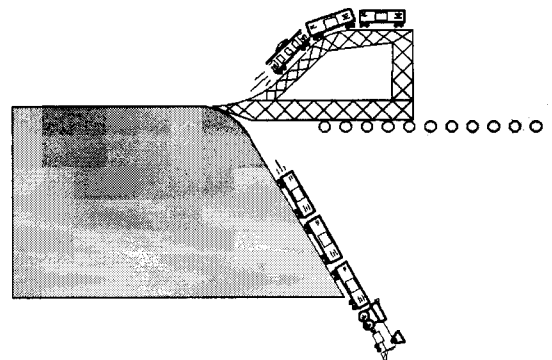

The trailing cars flow to a higher voltage.

Regulation by duty-cycle control

Figure 3 shows the inductor current for the two phases of the boost cycle. For most modern switching regulators, the frequency (f) of the switching action is fixed. This frequency can be as high as several megahertz but usually ranges from 10 to 300 kHz. Higher frequency operation has the advantages of smaller and lower cost inductors. The duty cycle, ρ , is the ratio of the time spent in phase I to the total time in one switching cycle (T). During steady-state operation, duty cycle is constant and varies only during changes in the load current. Because of this fact, the modern switching design has the advantage that spectral output (ac noise) is predictable and well-behaved.

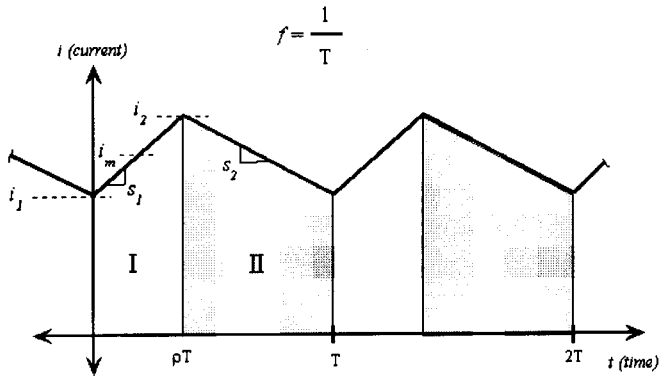

Figure 3 – Two phases of a boost cycle

The average input current to the circuit that Figure 3 represents is i_m . It is important to realize that the average output current is less and is $i_m(1-\rho)$ because it arrives at the load only during phase II of the switching cycle. For the average load current to increase or decrease to maintain regulation, the average level of the sawtooth-current waveform in Figure 3 must be controlled. You achieve this control by temporarily increasing the duty cycle for an attack phase and by temporarily decreasing the duty cycle for a decay phase. Notice that these changes in duty cycle are only temporary and that the switching duty cycle returns to a steady-state operating point once you establish the new average current level. Figures 4 and 5 graphically show the attack and decay phases, respectively.

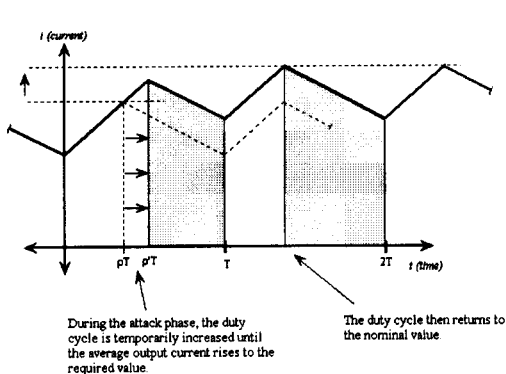

Figure 4 – The attack phase

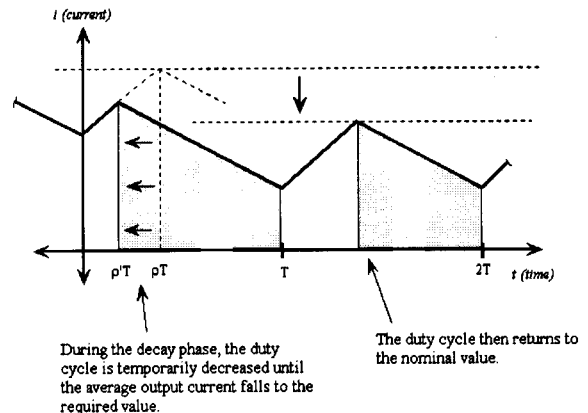

Figure 5 – The decay phase

The buck circuit

The buck circuit is similar in operation (**Figure 6**); however, the arrangement of the components is different. The benefit of the buck circuit is its ability to step down a voltage while maintaining much higher efficiencies than are possible with traditional linear regulators. During phase I of the buck cycle, the switch is closed, and current flows through the inductor. When the switch opens, the inductor “insists” that current must continue to flow. Thus, current draws from ground through the diode. Because the source supplies current only for that period when the switch is closed, the input current is less than the output current. This situation is unlike that of a linear regulator, in which the input current is always equal to or greater than the output current.

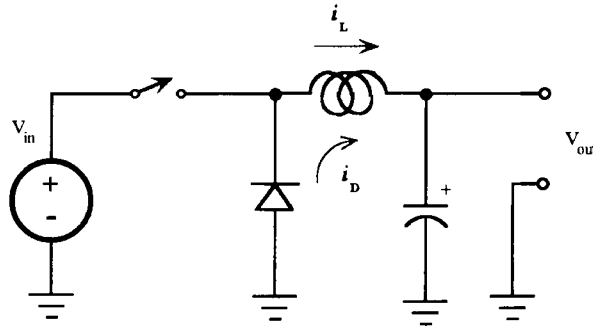

Figure 6 – Basic buck circuit

The current limit of the switching element primarily restricts the maximum limit for load current with the buck circuit. You achieve the maximum output current when the switch is on 100% of the time. Hence, a 1-to-1 relationship exists between switch ampacity and output current. This 1-to-1 relationship does not exist in most other switching topologies.

Isolated designs

Power-supply design often requires an isolated output. Isolation exists when there is no physical dc electrical connection or dc path between the input and the output.

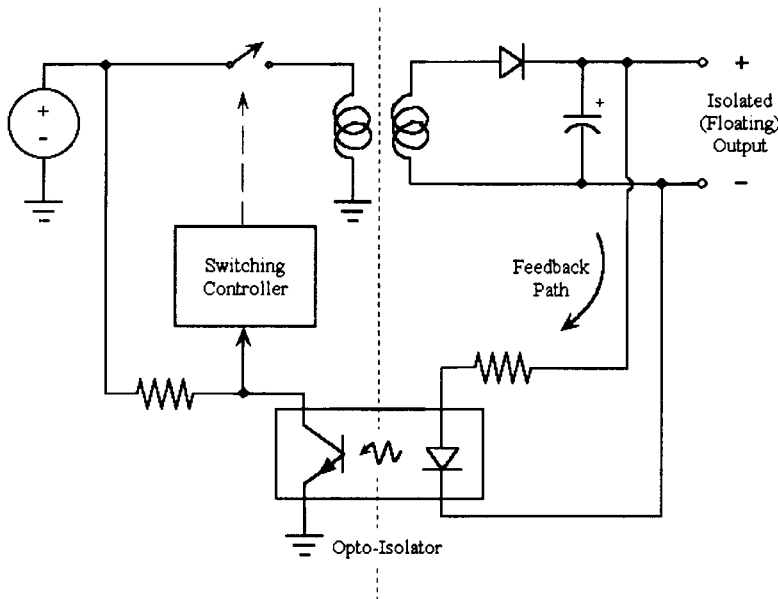

Figure 7 - Simplified isolated-switcher design

The most common way to achieve isolation is with transformers and optoisolators. You use the transformer to perform the isolated transfer of power to the load, and you use the optoisolator for the feedback signal. Safety reasons often dictate a need for isolated designs. If the primary-side voltages are derived from ac line, then the isolation provides electrical-shock protection for the secondary side. You can also ground an isolated output to any grounding system (within limits) without worry that ground-loop currents will flow. Note that by controlling the transformer turns ratio, the isolated topology can either buck or boost an input voltage. Also, because the output is isolated, you can obtain a negative output simply by grounding the positive output terminal. Because of these many advantages, the isolated design is very popular.

SEPIC designs

The SEPIC (single-ended primary-inductance-converter) circuit shows up periodically. One key advantage of the SEPIC topology is that it is a buck/boost switcher. This type is particularly useful in battery circuits in which the battery voltage may drop below the output voltage as the battery discharges. The SEPIC topology extends battery life because the battery can more fully discharge. **Figure 8** is a simplified diagram of the SEPIC circuit.

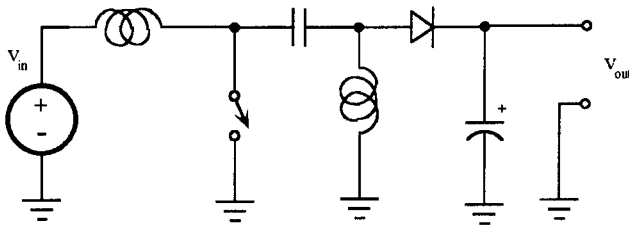

Figure 8 – Basic SEPIC topology

Although the output is capacitively coupled to the input, the SEPIC topology in **Figure 8** is not isolated. This fact is because the ground of the switch must connect to the ground of the secondary-side inductor to balance the charge on the coupling capacitor. The main drawback of the SEPIC is the presence of large ac currents in the main coupling capacitor. This ac ripple current dictates the size of the coupling capacitor and often results in a need for a physically large and often impractical capacitor.

The controller

To simplify the explanations, this article leaves out the details about how to control the switch for all of the aforementioned switching circuits. In real-world circuits, it is necessary to control the switching element and to do so in such a way that accommodates feedback for the purpose of voltage regulation.

Although several controller types exist for switching-power supplies, the voltage-mode SR (set/reset) flip-flop circuit is perhaps the simplest and most common. **Figure 9** illustrates this circuit. When the feedback voltage from the switching-circuit output is too low, the comparator output is high, and the clocking waveform passes through the AND gate. In this mode, the full duty cycle of the oscillator passes to the Q output of the SR flip-flop. When the feedback voltage is too high, the output of the comparator is low, and the AND gate inhibits and delays the setting action on the SR flip-flop. This situation extends the off time and reduces the duty cycle of the Q output. The circuit eventually reaches an equilibrium state, and maintaining steady-state regulation requires only small advances or retardations of the duty cycle. The attack and decay phases in **Figures 4** and **5** also show this action. Note that the frequency of the waveform at Q is constant as long as sufficient current draw exists. If the current draw drops to a very low level, this circuit goes into a “pulse-skipping” mode in which, for some cycles, no output pulse exists at all. A lower

switching frequency results because some pulses are totally removed from the otherwise constant frequency-switching waveform at Q.

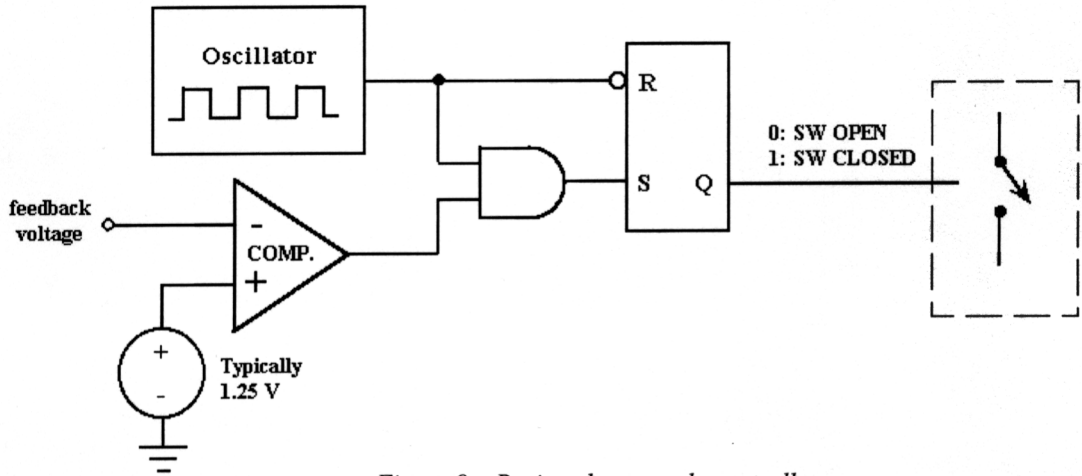

Figure 9 – Basic voltage-mode controller

Losses and efficiency

The key benefits of switching regulation are the high efficiencies that are possible. Switching regulation steps up or steps down current without paying the $V \cdot I$ penalty that you encounter with linear regulation. The FET switch, the inductor, and the catch diode, among other places, lose some power. The overall efficiency of the switching circuit is the ratio of power output to power input and is usually in the 70 to 95% range.

$$v_{out} \cdot i_{out} = \frac{\varepsilon}{100\%} \cdot v_{in} \cdot i_{in}$$

where ε = % efficiency

Curious behavior at the input

An interesting phenomenon that occurs with switching regulators is the presence of negative dc resistance at the input to the switcher. This event happens because the input current to most switching circuits goes down when the input voltage increases! Because the effective negative resistance of the input is quite high, this behavior can create stability problems only if the switcher drives from a very high source impedance.

Conclusion

Although mystifying at first glance, switching circuits are relatively straightforward. Once you understand the theory of the basic boost circuit, the operational theory of the more advanced topologies becomes clearer. The high efficiencies of switchers make them ideal for battery-operated applications. Switchers' ability to boost dc voltages and to provide isolation makes them a popular choice for a variety of other design applications as well.

Author

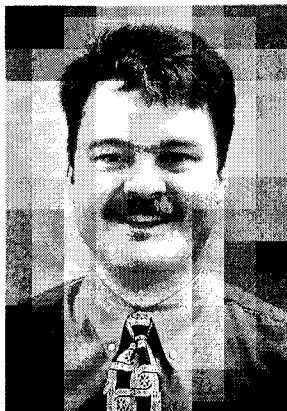

Tom Mathews is a staff field-applications engineer for National Semiconductor in Indianapolis, IN. Mathews has an MSEE from Purdue University (West Lafayette, IN) and has worked with analog and RF for more than 10 years. You can reach him at 317-705-6504.

References

1. Gross, Tom, *LM2577 Three Output, Isolated Flyback Regulator*, National Semiconductor AN-777, April 1998.
2. Gottlieb, Irving M, *Power Supplies, Switching Regulators, Inverters, and Converters*, TAB Books, a division of McGraw-Hill Inc, New York, NY, 1994.
3. Ambatipudi, Ravindra, *Design of Isolated Converters Using Simple Switchers*, National Semiconductor AN-1095, August 1998.