

UNTUNED POTENTIAL AMPLIFIERS

4-1. Basic Considerations. It is frequently necessary to achieve a higher gain in an amplifier than is possible with a single amplifier stage. In such cases, the amplifier stages are cascaded to achieve this higher gain, the output potential from one stage serving as the input potential to the next stage.

A number of factors influence the number and the characteristics of the individual stages which must be used to meet certain previously specified requirements. Among the factors which must be taken into account in amplifier design are the total over-all gain required, the shape of the frequency-response characteristic, and the over-all bandwidth. Certain factors exist which impose limits to the sensitivity which may be achieved, among these being the inherent noise generated in such devices. The requirements for stability of operation impose severe practical restrictions on the techniques of construction. Because of the several factors that play a part in amplifier design, gains in excess of about 10⁶, or 120 db potential gain, are extremely difficult to achieve. Depending on the bandwidth considerations, amplifiers seldom exceed six to nine stages in cascade for stable operation. Extreme caution is required in the design of such multistage amplifiers.

To calculate the over-all gain and frequency response of a multistage amplifier, the equivalent circuit of the amplifier must be drawn. The rules for accomplishing this are given in Sec. 2-6. The resultant equivalent network is then analyzed as a conventional problem in a-c circuit analysis.

A variety of coupling networks between the cascaded stages are possible, and a few have become very common, either because of their simplicity or because of some especially desirable characteristic. A number of the more common types will be considered in this chapter in some detail.

4-2. Resistance-Capacitance (RC) Coupled Amplifier. The resistance-capacitance (RC) coupled amplifier, illustrated in Fig. 4-1, is one of the more common and more important amplifier circuits. This amplifier circuit is used when a sensibly constant amplification over a wide

range of frequencies is desired. By the use of tubes with high amplification factors, it is possible to achieve a gain of 50 or more per stage. It will be found that high-gain triodes possess certain inherent disadvantages, and it is frequently desirable to use pentodes instead. If pentodes are used, the screen potential must remain constant; otherwise the following analysis will no longer be valid.

The capacitors C_1 , C_2 , and C_3 in this schematic diagram are known as *coupling*, or *blocking*, capacitors and serve to prevent any d-c potentials that are present in one stage from appearing in another stage. That is, capacitor C_1 serves to prevent any d-c potential in the input from appearing across the grid resistor R_{g1} and thus changing the d-c operating level of the amplifier. Capacitor C_2 serves a similar function in coupling stage 1 to stage 2. The value of the coupling capacitors is determined

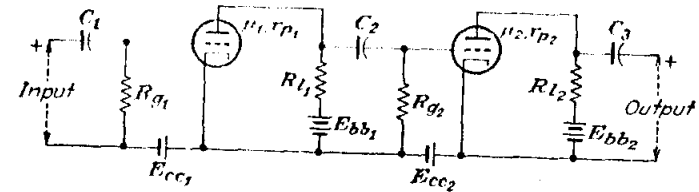

FIG. 4-1. Schematic diagram of a two-stage RC coupled amplifier.

primarily by the l-f amplification. They ordinarily range from about 0.001 to 0.1 μ f for conventional a-f stages. The resistor R_g , which is known as the *grid resistor*, furnishes a path by which the grid-bias supply is applied to the grid. It also serves as a leak path through which any electrons that may be collected by the grid from the electron stream within the tube may be returned to the cathode. If such a leak path were not provided, the grid would acquire a negative potential with the collection of the electrons, thus influencing the operation of the tube. A negative-bias supply potential is ordinarily used, and the grid current is usually very small. This permits the use of relatively large resistances for R_g , say from 50 kilohms to 2 megohms. Large values of R_g are desirable in achieving a wide frequency response. The load resistor R_l is determined principally by the gain and the frequency bandwidth that are desired, as will be shown below.

The equivalent circuit of the amplifier of Fig. 4-1 is shown in Fig. 4-2. This circuit is valid for triodes, tetrodes, or pentodes provided that the screen potential of the latter two is maintained constant. In this circuit E_1 denotes the a-c input potential applied to the grid of the first stage. This potential appears across the parallel combination consisting of the resistor R_{g1} in parallel with the input impedance to the amplifier. The interelectrode capacitances are not shown on the diagram, but

their effect is contained in the effective input capacitance C_e to each stage. That is, the input impedance of the stage is considered to comprise a resistance (assumed positive) in parallel with the input capacitance. It is also supposed that the impedance of the driving source is low, so that the loading by the total input impedance of the first stage does not affect the input potential. The output circuit of the first stage consists of the load resistance, the coupling capacitance C_2 , output tube and wiring capacitances, and the total input impedance of the second

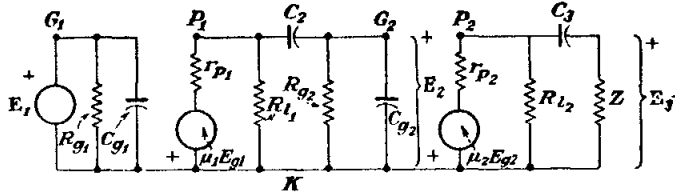

FIG. 4-2. The equivalent circuit of the RC amplifier of Fig. 4-1.

stage. This is denoted as R_e and C_e for the total resistive and capacitive components. The output of the amplifier is the potential across the output impedance, which is denoted by the symbol Z . This impedance cannot be specified more completely until the nature of the output circuit is known.

The coupling between the grid and the plate of the tubes through the interelectrode capacitances can be neglected over a wide frequency range with pentodes and over the a-f range with triodes. Consequently each stage may be considered as independent of the following stage, but the output of one stage is the input to the next stage. As a result, it follows that since

$$K_1 = \frac{E_2}{E_1} = \frac{\text{output potential of 1st stage}}{\text{input potential to 1st stage}}$$

and

$$K_2 = \frac{E_3}{E_2} = \frac{\text{output potential of 2d stage}}{\text{input potential to 2d stage}} \\ = \frac{\text{output potential of 2d stage}}{\text{output potential of 1st stage}}$$

then the resultant over-all gain is

$$K = \frac{E_3}{E_1} = \frac{\text{output potential of 2d stage}}{\text{input potential to 1st stage}}$$

It follows from these expressions that

$$K = K_1 K_2 \quad (4-1)$$

By taking twenty times the logarithm of the magnitude of this expression

$$20 \log_{10} K = 20 \log_{10} K_1 + 20 \log_{10} K_2 \quad (4-2)$$

It follows from this that the total decibel potential gain of the multi-stage amplifier is the sum of the decibel potential gains of the separate stages. This fact is independent of the type of interstage coupling.

4-3. Analysis of RC Coupled Amplifier. A typical stage of the RC coupled amplifier is considered in detail. This stage might represent any of a group of similar stages of an amplifier chain, except perhaps the out-

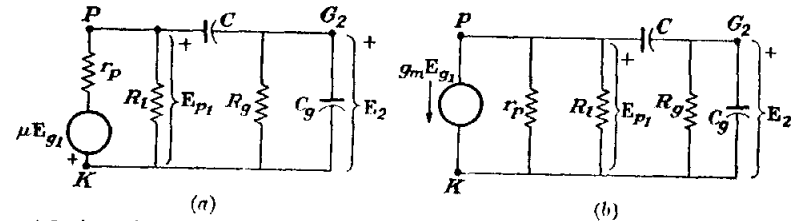

FIG. 4-3. A typical stage of an RC coupled amplifier. (a) Potential-source and (b) current-source equivalents.

put stage. Representative subscripts have been omitted. The equivalent circuit is given in its two forms in Fig. 4-3.

The typical stage will be analyzed by two methods in order to show the features of the methods. One method will employ the Millman theorem, as applied to Fig. 4-3a. The second method will employ a straightforward junction solution of Fig. 4-3b.

A direct application of the Millman theorem between the points G_2 and K yields the expression

$$E_2 = \frac{E_{p1} Y_C}{Y_C + Y_{R_p} + Y_{C_e}} \quad (4-3)$$

where $Y_C = j\omega C$, $Y_{R_p} = 1/R_p$, $Y_{C_e} = j\omega C_e$. An application of this theorem between the points P_1 and K yields the expression

$$E_{p1} = \frac{-\mu E_{g1} Y_p + E_2 Y_C}{Y_p + Y_l + Y_C} \quad (4-4)$$

where $Y_p = 1/r_p$ and $Y_l = 1/R_l$. By combining Eq. (4-3) with Eq. (4-4) and solving for the gain $K = E_2/E_{g1}$, since $E_{g1} = E_1$, there results

$$K = \frac{-\mu Y_p Y_C}{(Y_C + Y_{R_p} + Y_{C_e})(Y_p + Y_l) + Y_C(Y_{R_p} + Y_{C_e})} \quad (4-5)$$

This is the complete expression for the potential gain of such an amplifier stage. If the constants of the circuit are known, the gain and phase-shift characteristics as a function of frequency may be calculated.

Now refer to Fig. 4-3b, and apply the standard techniques of junction analysis. The controlling equations, obtained from considerations of the Kirchhoff current law, are

$$\begin{aligned} (\mathbf{Y}_p + \mathbf{Y}_l + \mathbf{Y}_C)\mathbf{E}_{p1} - \mathbf{Y}_C\mathbf{E}_2 &= -g_m\mathbf{E}_{g1} \\ -\mathbf{Y}_C\mathbf{E}_{p1} + (\mathbf{Y}_C + \mathbf{Y}_{C_s} + \mathbf{Y}_{R_s})\mathbf{E}_2 &= 0 \end{aligned} \quad (4-6)$$

By determinantal methods, it follows that

$$\mathbf{K} = \frac{\mathbf{E}_2}{\mathbf{E}_1} = \frac{\begin{vmatrix} \mathbf{Y}_p + \mathbf{Y}_l + \mathbf{Y}_C & -g_m \\ -\mathbf{Y}_C & 0 \end{vmatrix}}{\begin{vmatrix} \mathbf{Y}_p + \mathbf{Y}_l + \mathbf{Y}_C & -\mathbf{Y}_C \\ -\mathbf{Y}_C & \mathbf{Y}_C + \mathbf{Y}_{C_s} + \mathbf{Y}_{R_s} \end{vmatrix}} \quad (4-7)$$

The expansion of these determinants by Cramer's rule yields Eq. (4-5), as it must.

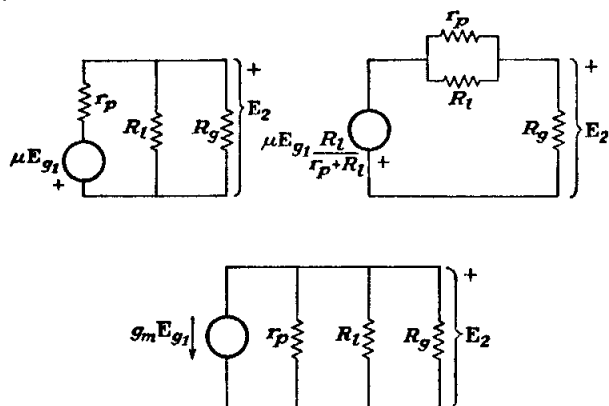

FIG. 4-4. The mid-frequency equivalent circuits of the RC amplifier.

It will be found convenient to analyze the response of the amplifier for limiting regions of frequency instead of attempting an interpretation of Eq. (4-5) directly. In fact, in many cases it is more convenient to analyze the appropriate equivalent circuit, rather than attempt the analysis from Eq. (4-5).

Intermediate Frequencies. The intermediate frequencies, or mid-frequencies, are those for which \mathbf{Y}_C is large and \mathbf{Y}_{C_s} is small. Subject to these conditions, the equivalent circuits of Fig. 4-3 reduce to those shown in Fig. 4-4.

For the range of frequencies over which this equivalent circuit is valid, the expression for the gain becomes

$$\mathbf{K} = \mathbf{K}_0 = \frac{-g_m}{\mathbf{Y}_p + \mathbf{Y}_l + \mathbf{Y}_{R_s}} \quad (4-8)$$

This expression for the gain is independent of the frequency, since no reactive elements appear in the circuit. Each parameter in the equation is a conductance, and because of the negative sign the relative phase angle between the input and output potentials is constant and equal to 180 deg.

L-F Region. At the low frequencies the effect of C_s is negligible, and \mathbf{Y}_{C_s} may be made zero. The effect of the coupling capacitor C becomes very important. The equivalent circuit under these conditions has the

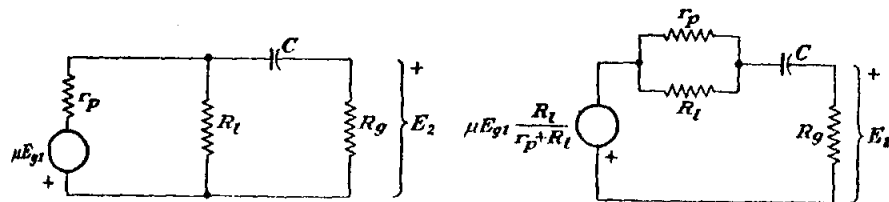

FIG. 4-5. The l-f equivalent circuit of the RC amplifier.

form shown in Fig. 4-5. The general expression for the gain [Eq. (4-5)] reduces to

$$\mathbf{K} = \mathbf{K}_1 = \frac{-\mu\mathbf{Y}_p\mathbf{Y}_C}{\mathbf{Y}_C(\mathbf{Y}_p + \mathbf{Y}_l + \mathbf{Y}_{R_s}) + \mathbf{Y}_{R_s}(\mathbf{Y}_p + \mathbf{Y}_l)} \quad (4-9)$$

It is found convenient to examine the l-f gain relative to the mid-frequency gain. The ratio $\mathbf{K}_1/\mathbf{K}_0$ becomes

$$\frac{\mathbf{K}_1}{\mathbf{K}_0} = \frac{1}{1 + \frac{\mathbf{Y}_{R_s}(\mathbf{Y}_p + \mathbf{Y}_l)}{\mathbf{Y}_C(\mathbf{Y}_p + \mathbf{Y}_l + \mathbf{Y}_{R_s})}} \quad (4-10)$$

This may be written in the simple form, for any frequency f ,

$$\frac{\mathbf{K}_1}{\mathbf{K}_0} = \frac{1}{1 - j(f_1/f)} \quad (4-11)$$

where

$$f_1 = \frac{\mathbf{Y}_{R_s}(\mathbf{Y}_p + \mathbf{Y}_l)}{2\pi C(\mathbf{Y}_p + \mathbf{Y}_l + \mathbf{Y}_{R_s})} \quad (4-12)$$

If the load is a pure resistance, then f_1 is a real number and the magnitude of the relative gain becomes

$$\frac{K_1}{K_0} = \frac{1}{\sqrt{1 + (f_1/f)^2}}$$

where

$$f_1 = \frac{1}{2\pi C \left[R_s + \frac{r_p R_l}{r_p + R_l} \right]} \quad (4-13)$$

This shows that the parameter f_1 represents the frequency at which the gain falls to $1/\sqrt{2}$, or 70.7 per cent of its mid-frequency value. This frequency is usually referred to as the *l-f cutoff* frequency of the amplifier. The relative phase angle θ_1 is given by

$$\tan \theta_1 = \frac{f_1}{f} \quad (4-14)$$

This approaches 90 deg as the frequency approaches zero.

It should be noted that the l-f cutoff value [Eq. (4-12)] depends, among other terms, on the size of the coupling capacitor C . Since the value of C appears in the denominator of the expression for f_1 , then, for a decreased l-f cutoff, larger values of C must be chosen. Of course, the gain must ultimately fall to zero at zero frequency.

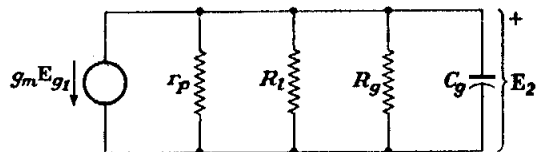

FIG. 4-6. The h-f equivalent circuit of the RC amplifier.

There are several practical limitations to the size of the coupling capacitance that may be used. The capacitor must be of high quality so that any leakage current will be small. Otherwise a conduction path from the plate of one stage to the grid of the next stage may exist. But good-quality capacitors in sizes greater than $0.1 \mu\text{f}$ are physically large and are relatively expensive. Also, if the coupling capacitance is large, a phenomenon known as *blocking* may result. This arises when the time constant CR_o is much larger than the period of the highest frequency to be passed by the amplifier. Thus, if an appreciable charge flows into the capacitor with the application of the input signal and if this cannot leak off quickly enough, a charge will build up. This may bias the tube highly negatively, perhaps even beyond cutoff. The amplifier then becomes inoperative until the capacitor discharges. This condition is sometimes desirable in special electron-tube circuits and will be the subject of a detailed discussion in Chap. 9. However, it is a condition that must be avoided in an amplifier that is to reproduce the input signal in an amplified form.

The grid resistance R_o must be made high to keep the gain high, since R_o of one stage represents a loading across the plate resistance R_i of the previous stage. The upper limit to this value is set by the grid current. Ordinarily the grid current is small, particularly when the grid bias is negative. But if the grid resistance is made too high, and several megohms is the usual limit, the potential across this resistance will act as a

spurious bias on the tube. While special low-grid-current tubes are available, these are designed for special operations and would not ordinarily be used in conventional circuits.

H-F Region. At the high frequencies, the admittance of C is very large, and the admittance of C_o becomes important. The equivalent circuit corresponding to these conditions becomes that shown in Fig. 4-6. The general expression for the gain reduces to

$$\mathbf{K} = \mathbf{K}_2 = \frac{-\mu \mathbf{Y}_p}{\mathbf{Y}_p + \mathbf{Y}_i + \mathbf{Y}_{R_o} + \mathbf{Y}_{C_o}} \quad (4-15)$$

The gain ratio $\mathbf{K}_2/\mathbf{K}_0$ becomes

$$\frac{\mathbf{K}_2}{\mathbf{K}_0} = \frac{1}{1 + \frac{\mathbf{Y}_{C_o}}{\mathbf{Y}_p + \mathbf{Y}_i + \mathbf{Y}_{R_o}}} \quad (4-16)$$

This expression may be written in a form similar to Eq. (4-11) for the l-f case. It becomes

$$\frac{\mathbf{K}_2}{\mathbf{K}_0} = \frac{1}{1 + j(f/f_2)} \quad (4-17)$$

where

$$f_2 \equiv \frac{\mathbf{Y}_p + \mathbf{Y}_i + \mathbf{Y}_{R_o}}{2\pi C_o} \quad (4-18)$$

In this expression C_o denotes the total capacitance from grid to cathode and comprises the input capacitance of the following stage, the output wiring, and the output tube capacitance.

If the load is a pure resistance, then f_2 is a real number and the magnitude of the relative gain becomes

$$\frac{K_2}{K_0} = \sqrt{\frac{1}{1 + (f/f_2)^2}} \quad (4-19)$$

It follows from this that f_2 represents that frequency at which the h-f gain falls to $1/\sqrt{2}$, or 70.7 per cent, of its mid-frequency value. This frequency is usually referred to as the *h-f cutoff* of the amplifier. The relative phase angle θ_2 is given by

$$\tan \theta_2 = -\frac{f}{f_2} \quad (4-20)$$

This angle approaches -90 deg as the frequency becomes very large compared with f_2 .

Note from Eq. (4-18) that the h-f cutoff value depends on the value of C_o , among other factors. Since the value of C_o appears in the denominator of the expression, then clearly a high h-f cutoff requires a small value

of C_o . Moreover, since the input capacitance of a pentode is appreciably less than that of a triode, the pentode possesses inherently better possibilities for a broad frequency response than does the triode. It will be found in Sec. 5-11, in the discussion of the cathode-follower amplifier, that triodes with cathode-follower coupling stages also possess broad-band capabilities, although this is accomplished at the expense of a tube. Note above that the h-f cutoff is improved by the use of large Y_p , Y_t , and

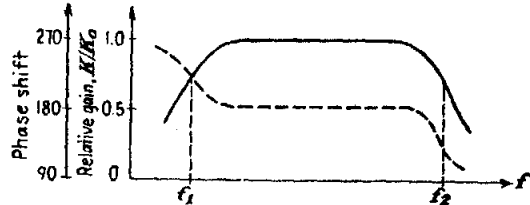

FIG. 4-7. A typical frequency response and phase characteristic of an RC coupled amplifier.

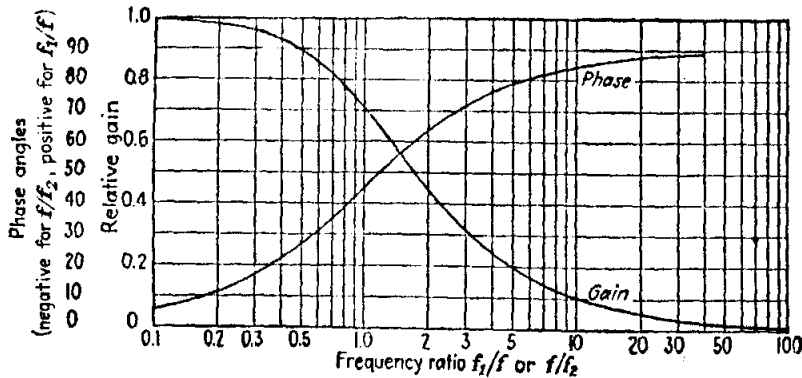

FIG. 4-8. Universal gain and phase-shift curves for an RC coupled amplifier.

Y_p , which implies the use of small values of resistance R_1 , R_o and a tube with a small plate resistance.

4-4. Universal Amplification Curves for RC Amplifiers. The foregoing analysis shows that the gain of an RC coupled amplifier is substantially constant over a range of frequencies and falls off at both the high and the low frequencies. A typical frequency-response curve has the form sketched in Fig. 4-7.

Since the relative gain and the relative phase-shift characteristics depend only upon the two parameters f_1 and f_2 , it is possible to construct curves which are applicable to any such amplifier. Such universal curves are given in Fig. 4-8.

The frequency-response characteristics of any RC coupled amplifier can easily be obtained with the aid of these curves. The first step in the

analysis is to calculate the values of the parameters f_1 and f_2 from Eqs. (4-12) and (4-18). Then the values of the relative gain and the relative phase angle are obtained from the curves for a number of values of the ratio f_1/f and f/f_2 . These are plotted as a function of f . It must be remembered in using Fig. 4-8 that the ordinate is K_1/K_0 or θ_1 when the abscissa is f_1/f . Also, the ordinate is K_2/K_0 or θ_2 when the abscissa is f/f_2 .

4-5. Cascaded Amplifiers. A junction-transistor amplifier will ordinarily consist of several stages in cascade coupled by passive networks. Care must be exercised in the choice of stages so that one stage does not load the previous stage. Several representative forms will be discussed in order to bring into focus important operating features of each.

The circuit of Fig. 4-9 illustrates a typical stage of an RC coupled transistor amplifier in a grounded-emitter connection. As already noted, this connection corresponds roughly to the grounded-cathode triode circuit. In this diagram resistors R_1 , R_2 , and R_3 provide the required bias to the collector and base. Resistor R_4 is employed to reduce the variation of the collector current with temperature. Capacitors C_1 are coupling capacitors between stages, and C_2 serves to bypass resistor R_4 . Without C_2 in the circuit, the presence of R_4 would result in a reduced amplification.

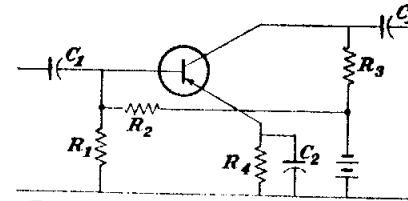

FIG. 4-9. A typical RC coupled amplifier stage.

If the stage is properly designed, resistances R_1 and R_2 are large compared with the input resistance of the stage. Also, the capacitors C_1 and C_2 will have effectively zero impedance over the frequency range of interest. Therefore, in so far as audio frequencies are concerned, the approximate circuit does not require the external R 's and C 's. Consequently, a representative multistage amplifier would have the form illustrated in Fig. 4-10.

The resistors R_c are not required for circuits utilizing junction transistors. They may be required when point-contact transistors are used. However, as noted before, point-contact transistors are generally not used in such applications. The equivalent circuit for a single stage is given in Fig. 4-10b, which is precisely of the form illustrated in Fig. 3-13. The pertinent information is contained in Table 3-2. If no loading exists between stages, the over-all results follow from this table. A complete circuit diagram of a cascaded amplifier is given in Fig. 4-11.

A grounded-base cascaded amplifier may be sketched. In the light of the analogy between this transistor circuit and the grounded-grid triode amplifier, the direct cascading of grounded-base amplifiers is to be avoided, owing to the poor impedance-matching properties at both the

input and output terminals. The use of coupling transformers which are designed to match the output resistance of one stage to the input resistance of the next stage permits the satisfactory operation of a cascaded chain of grounded-base amplifiers. Figure 4-12a shows such a transformer-coupled amplifier. The equivalent circuit for a-c operation is

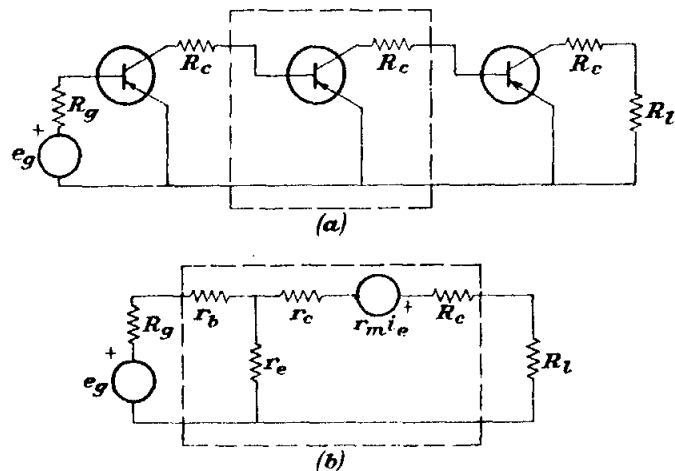

FIG. 4-10. (a) Schematic diagram of a cascaded grounded-emitter amplifier. (b) Equivalent circuit for a single stage.

given in Fig. 4-12b, and the simplified single-stage equivalent circuit is illustrated in Fig. 4-12c. This circuit is precisely that illustrated in Fig. 3-13, the results of importance being contained in Table 3-1.

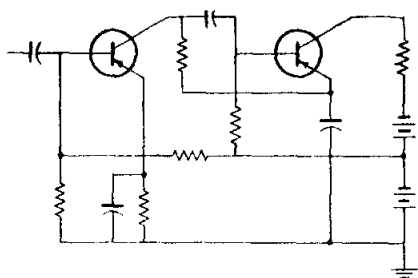

FIG. 4-11. A grounded-emitter grounded-base cascade amplifier.

In addition to such external effects as occur through capacitances and feedback, the internal effect resulting from the finite time for the electrons and holes to diffuse through the transistor also becomes important at the high frequencies. Because of this latter factor, it is anticipated that α will vary with frequency. The character of the variation of α with frequency

As in vacuum-tube circuitry, transistor amplifiers of different types may be cascaded. The circuit of Fig. 4-13 illustrates a grounded-emitter grounded-base cascade. A grounded-collector cascade, which is analogous to a chain of cathode-follower circuits, would ordinarily not be used.

4-6. H-F Operation. A number of transistor parameters are frequency-dependent functions. In

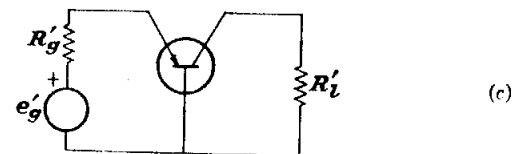
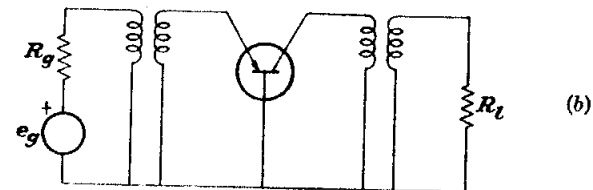
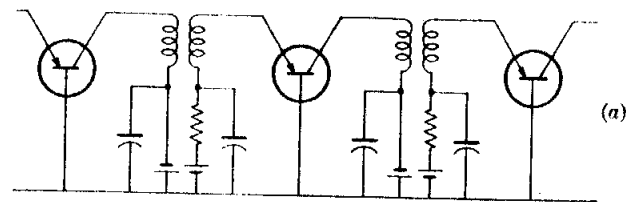

FIG. 4-12. (a) A grounded-base transformer-coupled amplifier, (b) an equivalent single stage, (c) a simplified single stage.

is represented with good approximation³ by the expression

$$\alpha = \frac{\alpha_0}{1 + jf/f_0} \quad (4-21)$$

where α_0 is the l-f value of α and f_0 is the frequency at which the magnitude of α is 3 db down from its l-f value. Experimental curves showing the variation with frequency of α are given in Fig. 4-14.

Consider, for example, the simple grounded-base transistor amplifier, the equivalent circuit of which is illustrated in Fig. 3-13. Owing to the relatively low input impedance of this circuit, the current I_1 is almost a constant. Also in this circuit E_1 denotes the potential across the input impedance of the amplifier. The circuit equations thus follow directly as

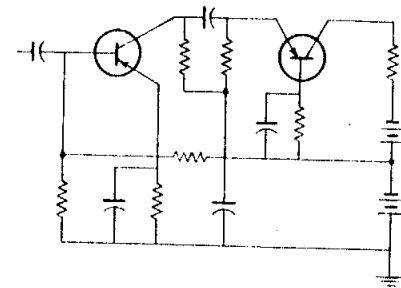

FIG. 4-13. A grounded-emitter grounded-base cascaded amplifier.

$$\begin{aligned} (r_e + r_b)I_e - r_b I_c &= E_1 = I_c Z_i \\ -(r_b + r_m)I_e + (r_c + r_b + R_l)I_c &= 0 \end{aligned} \quad (4-22)$$

The first of these equations reduces to the second, as may be shown by including the appropriate value for Z_i from Table 3-1. Therefore the

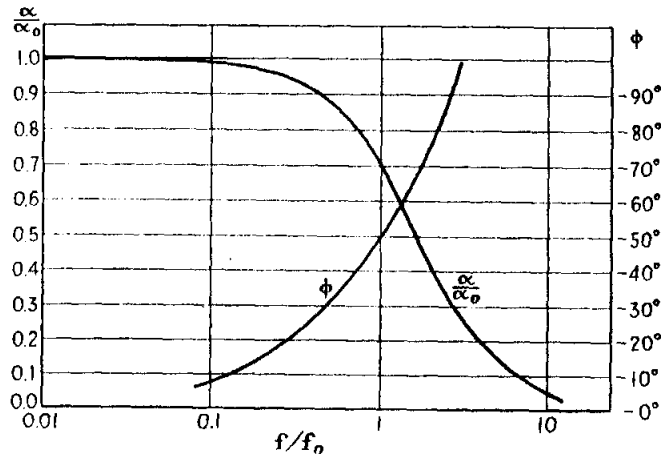

FIG. 4-14. The variation of α with frequency for a typical junction transistor. (From R. F. Shea et al., "Principles of Transistor Circuits," John Wiley & Sons, Inc., New York, 1953, with permission.)

ratio I_c/I_e from the second of these equations is

$$\frac{I_c}{I_e} = \frac{r_b + r_m}{r_c + r_b + R_l} \quad (4-23)$$

But from the definition of α and Eq. (2-42b)

$$\alpha = \frac{r_b + r_m}{r_b + r_c} \quad (4-24)$$

Combine this expression with Eq. (4-23) to find

$$\frac{I_c}{I_e} = \frac{\alpha}{1 + R_l/(r_b + r_c)} \quad (4-25)$$

Now combine this with Eq. (4-21) to get

$$\frac{I_c}{I_e} = \frac{\alpha_0}{1 + R_l/(r_b + r_c)} \frac{1}{1 + jf/f_0} \quad (4-26)$$

This expression shows that the load cutoff characteristic varies directly with the variations in α .

The situation is actually more complicated⁴ than that specified in Eq. (4-26) for I_2 , since the capacitive component of the collector imped-

ance becomes important at the higher frequencies. Thus at the higher frequencies r_c must be replaced by the parallel combination of r_c and C_c , both of which are functions of the frequency, as shown in Fig. 4-15.

Because of the several effects at the higher frequencies, the input impedance to the junction-transistor circuit will be complex, in general.⁵ For the grounded-base circuit, the input impedance is inductive. For

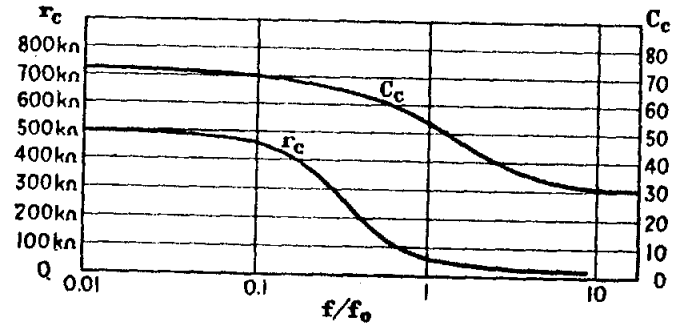

FIG. 4-15. The variation of r_c and C_c with frequency. (From R. F. Shea et al., "Principles of Transistor Circuits," John Wiley & Sons, Inc., New York, 1953, with permission.)

the grounded-emitter circuit, the input impedance is capacitive. Representative values of input impedance at $f_0/2$ are

Grounded-base stage: $Z_i \doteq 80 + j50$ ohms

Grounded-emitter stage: $Z_i \doteq 400 - j150$ ohms

4-7. Gain-Bandwidth Product. Suppose that it is desired to extend the h-f response of an RC coupled amplifier. According to the universal gain characteristic, this requires that the quantity f_2 be increased. By Eq. (4-18) this increase in f_2 may be accomplished by increasing any of the terms Y_p , Y_l , or Y_R , or by decreasing C_c . It is desired to examine the effect of varying these parameters.

Consider the factor Y_p . An increase in Y_p implies that the plate resistance r_p is reduced. This would seem to favor the use of triodes with low values of r_p . However, tubes of this type are power triodes, which are low- μ tubes. Consequently, in addition to the low gain inherent in such tubes, and the corresponding high grid driving signal that would be required for reasonable output potential, the use of a triode is inadvisable because of the relatively large total input capacitance which such a stage would possess [see Eq. (3-16)], so that the influence of the increase in C_c would more than overcome the gain possible by increasing Y_p .

An increase in Y_l , which implies a reduction in the load resistance R_l , will also be accompanied by an increased value of f_2 . Thus while there is an increase in the bandwidth of the amplifier, the gain is thereby

reduced. Suppose that the tube that is used is a pentode, and this is generally the case for a broad-band amplifier, since, as just discussed, the triode is subject to serious limitations for this service and is not used. For the pentode, since r_p is large (and of the order of 1 megohm) and R_o may also be made large, the h-f cutoff value is given with good approximation by

$$f_2 = \frac{Y_1}{2\pi C_o} = \frac{1}{2\pi R_1 C_o} \quad (4-27)$$

Moreover, for the pentode, the gain of the stage is given with good approximation by

$$K_2 = g_m R_1 \quad (4-28)$$

If it is assumed that the l-f cutoff is small, so that f_2 denotes the total bandwidth of the amplifier, then the gain-bandwidth product is

$$K_2 B = \frac{g_m}{2\pi C_o} \quad (4-29)$$

Observe from this expression that the gain-bandwidth product of the RC coupled amplifier is a constant. This means that, by changing a circuit parameter to increase the gain, the bandwidth of the system is reduced; one is obtained at the expense of the other for a given tube and a given circuit configuration.

Since the gain of the stage is proportional to g_m of the tube, and since the bandwidth, for a given gain, is proportional to $1/C_o$ in a given circuit configuration, the limit to the bandwidth is dictated fundamentally by the interelectrode capacitances of the tube. Thus even if the wiring and socket capacitances were reduced to zero, an impossible practical situation, the sum of the output capacitance of the one tube and the input capacitance to the following stage would provide the ultimate limitation. That is, the ultimate limit is imposed by an effective capacitance C_t , which is the output capacitance of one tube and the input capacitance to the next tube. For a chain of similar pentodes in cascade, the limiting gain-bandwidth product is given by

$$K_2 B = \frac{g_m}{2\pi(C_{in} + C_{out})} = \frac{g_m}{2\pi C_t} \quad (4-30)$$

From this expression, a quantity M is defined as

$$M = \frac{g_m}{C_t} \quad (4-31)$$

M is known as the *figure of merit* of the tube.

For service requiring a large gain-bandwidth product, the tube should possess a large transconductance in proportion to the input plus output

electrode capacitances. The 6AK5 and the 6AC7 are both highly satisfactory in this respect, the 6AK5 being slightly superior to the 6AC7. When allowance is made for socket and wiring capacitances, an average 6AK5 has a gain-bandwidth product of approximately 55 Mc (for the tube capacitances alone this figure is approximately 117 Mc) and an average 6AC7 has a corresponding value of 50 Mc.

4-8. Cascaded Stages. When identical stages are connected in cascade, a higher gain is provided, as required by Eq. (4-1). However, this higher gain is accompanied by a narrower bandwidth. It is desired to obtain expressions which show the effect of cascading identical amplifiers. This is done piecewise for the important frequency regions.

Consider that n identical stages are connected in cascade. In the mid-frequency range the resultant gain is constant and is given by

$$K_{0n} = (K_0)^n \quad (4-32)$$

For the l-f region, the relative gain for the n stages is given by

$$\left(\frac{K_1}{K_0}\right)^n = \frac{1}{[1 + (f_1/f)^2]^{n/2}} \quad (4-33)$$

The resulting l-f cutoff value is defined as that value for which the relative gain is reduced by $1/\sqrt{2}$. This requires that

$$\left[1 + \left(\frac{f_1}{f}\right)^2\right]^{n/2} = 2^{1/2} \quad (4-34)$$

from which

$$1 + \left(\frac{f_1}{f}\right)^2 = 2^{1/n}$$

so that

$$\frac{f_1}{f_{1n}} = \sqrt{2^{1/n} - 1} \quad (4-35)$$

The relative h-f gain for the n -stage amplifier is obtained exactly as for the l-f region and is given by

$$\left(\frac{K_2}{K_0}\right)^n = \frac{1}{[1 + (f/f_2)^2]^{n/2}} \quad (4-36)$$

The corresponding h-f cutoff value is then

$$\frac{f_{2n}}{f_2} = \sqrt{2^{1/n} - 1} \quad (4-37)$$

Table 4-1 gives the values of the cutoff frequency reduction function $\sqrt{2^{1/n} - 1}$. It is seen, for example, that the h-f cutoff value of two

identical stages in cascade is reduced by a factor 0.643. Correspondingly, the l-f cutoff value is increased by this same factor. This means, of course, that the total bandwidth of the amplifier decreases as the number of cascaded stages increases. To achieve specified over-all h-f and l-f cutoff values, the single-stage cutoff values must be correspondingly high and low, respectively.

TABLE 4-1

n	BANDWIDTH REDUCTION FACTOR $\sqrt{2^{1/n} - 1}$
1	1.0
2	0.643
3	0.510
4	0.435
5	0.387
6	0.350

4-9. Direct-coupled Amplifier. It is possible to build a type of cascaded amplifier without reactive elements and, in principle at least, secure a very broad-band amplifier. The potential gain of such an amplifier does not depend on the frequency, at least to a first approximation.

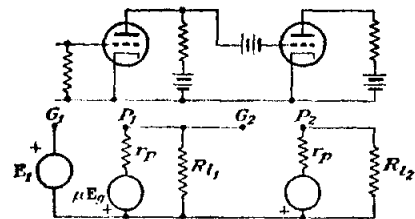

FIG. 4-16. Basic battery-coupled amplifier circuits.

is limited, though they find extensive employment as d-c amplifiers and as amplifiers for very slowly varying inputs.

A battery-coupled cascade-amplifier circuit of basic design, together with the equivalent plate circuit for small changes in potential and current, is shown in Fig. 4-16. The gain of such an amplifier stage is readily found to be

$$K = \frac{-\mu R_1}{r_p + R_1} \quad (4-38)$$

It will be observed that the circuits are quite like the RC coupled amplifier except that the coupling (blocking) capacitors are absent. Because of the fact that the grid of one stage is directly connected to the plate circuit of the previous stage, it is necessary to include d-c sources at the various critical points in the circuit in order that the quiescent conditions be those of class A operation.

The battery-coupled amplifier has the outstanding feature that it will amplify a steady component in the input voltage, but it suffers from three main disadvantages. The first is the cost of the relatively high-potential grid-bias batteries. These are required when a common plate and a common filament supply are used. In an alternative arrangement, indirectly heated cathodes having different potentials are used, thus obviating the necessity for large grid-bias potentials. However, separate plate supplies are required in this case.

The second disadvantage of the direct-coupled amplifier is the inherent instability associated with direct coupling. The characteristics of the

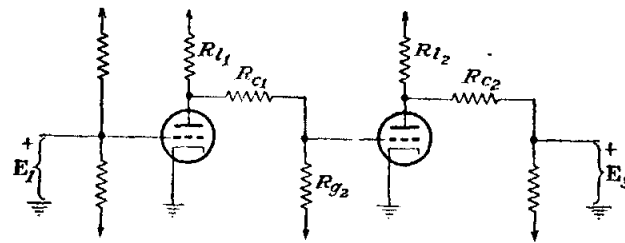

FIG. 4-17. A resistance-coupled amplifier.

tubes in the circuit change slightly with time; the battery potentials or the a-c line-operated rectified power supplies, likewise change with time. Since such changes are amplified, the d-c amplifier is not feasible unless precautions can be taken which tend to overcome this instability. For this reason, balanced circuits and circuits with degenerative feedback are used, since they tend to minimize this difficulty.

The third disadvantage arises from the capacitance between the grid-bias batteries and the cathodes. This, plus the interelectrode capacitances, stray wiring capacitance, and stray inductance, influences the transient-response time and materially affects the rapidity with which the amplifier output responds to rapid changes of input potential. In consequence, even though the amplifier is direct-coupled, precautions must be taken to ensure a broad h-f response in order to provide a short response time.

It is possible to build a direct-coupled amplifier that uses a positive plate supply, a negative bias supply, and resistance coupling networks. This overcomes the first disadvantage. The circuit of such an amplifier is illustrated in Fig. 4-17. The equivalent circuit of a typical stage of this amplifier is given in Fig. 4-18. The gain of such an amplifier is readily found to be

$$K = - \frac{\mu R_{g2} \frac{R_{11}}{R_{11} + R_{c1} + R_{g2}}}{r_p + \frac{R_{11}(R_{c1} + R_{g2})}{R_{11} + R_{c1} + R_{g2}}} \quad (4-39)$$

For an appreciable potential gain, the parallel combination of R_{i1} and $R_{c1} + R_{o2}$ should be large compared with r_p , and R_{o2} should be large compared with R_{c1} . This will necessitate the use of a large bias supply.

Direct-coupled amplifiers are used extensively as the amplifier in a circuit the grid exciting source of which has a very high internal resistance or which is capable of supplying only a very small current. In this case, the grid current must be very small. In particular, the grid current is significant when the grid-cathode resistance of the tube, though high, might not be large in comparison with the resistance of the circuit that supplies the grid signal voltage. Special electrometer tubes in which the grid current is of the order of 10^{-15} amp are available for such applications. The grid current of the typical negative-grid tube is of the order of 10^{-8} amp with normal rated potential applied to the tube electrodes. With the electrode potentials at very low values, the grid current may be reduced as low as 10^{-12} amp. More will be said about the applications of such amplifiers in Chap. 20.

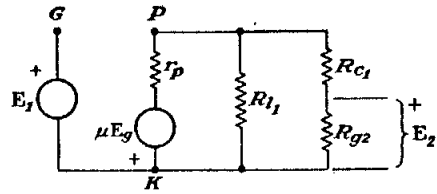

FIG. 4-18. The equivalent circuit of a typical stage of the resistance-coupled amplifier of Fig. 4-17.

The grid current of the typical negative-grid tube is of the order of 10^{-8} amp with normal rated potential applied to the tube electrodes. With the electrode potentials at very low values, the grid current may be reduced as low as 10^{-12} amp. More will be said about the applications of such amplifiers in Chap. 20.

4-10. The Cathode-coupled Amplifier. A two-tube circuit which is used extensively as a direct-coupled amplifier, owing to certain self-balancing features, and which is often used as an a-c amplifier, is illustrated

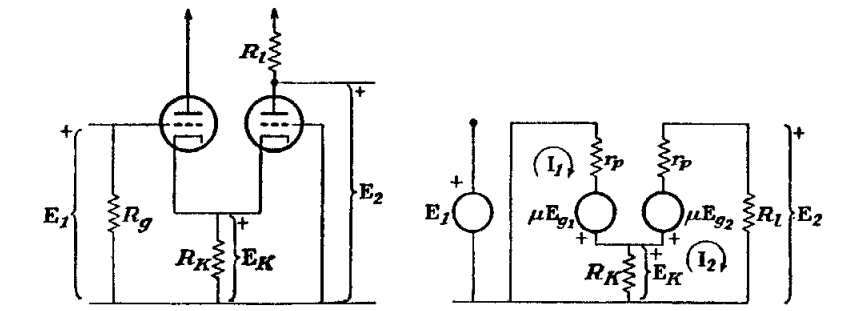

FIG. 4-19. A cathode-coupled amplifier and its equivalent circuit.

in Fig. 4-19. This circuit overcomes the first disadvantage of the previous section and permits the use of a common battery supply for all stages.

To analyze the operation of the circuit, the Kirchhoff potential law is applied to the loop circuits shown. The tubes are assumed to be identical. Hence, there follows

$$\begin{aligned} E_{o1} &= E_1 - E_k = E_1 - (I_1 - I_2)R_k \\ E_{o2} &= -E_k = -(I_1 - I_2)R_k \end{aligned} \quad (4-40)$$

$$\begin{aligned} I_1 r_p - \mu E_{o1} + E_k &= 0 \\ I_2(r_p + R_i) + \mu E_{o2} - E_k &= 0 \end{aligned}$$

Write the equations in the form

$$\begin{aligned} I_1[r_p + (\mu + 1)R_k] - I_2(\mu + 1)R_k &= \mu E_1 \\ -I_1(\mu + 1)R_k + I_2[r_p + (\mu + 1)R_k + R_i] &= 0 \end{aligned}$$

The solution of these equations yields, for current I_2 ,

$$I_2 = \frac{\mu(\mu + 1)R_k E_1}{[r_p + (\mu + 1)R_k][r_p + (\mu + 1)R_k + R_i] - [(\mu + 1)R_k]^2} \quad (4-41)$$

The output potential E_2 is

$$E_2 = I_2 R_i = \frac{\mu(\mu + 1)R_k R_i E_1}{[r_p + (\mu + 1)R_k][r_p + (\mu + 1)R_k + R_i] - [(\mu + 1)R_k]^2} \quad (4-42)$$

Now write this as

$$E_2 = \frac{\mu R_i E_1}{2r_p + \frac{r_p(r_p + R_i)}{(\mu + 1)R_k} + R_i} \quad (4-43)$$

If the parameters are so chosen that $r_p + R_i \ll (\mu + 1)R_k$, then approximately

$$E_2 = \frac{\mu R_i E_1}{2r_p + R_i} \quad (4-44)$$

which is a form quite like that for the ordinary single-tube amplifier, except for the appearance of the factor $2r_p$ in the denominator instead of simply r_p . Note also that the output potential has the same phase as the input potential. A typical circuit showing a cascade cathode-coupled amplifier is given in Fig. 4-20.

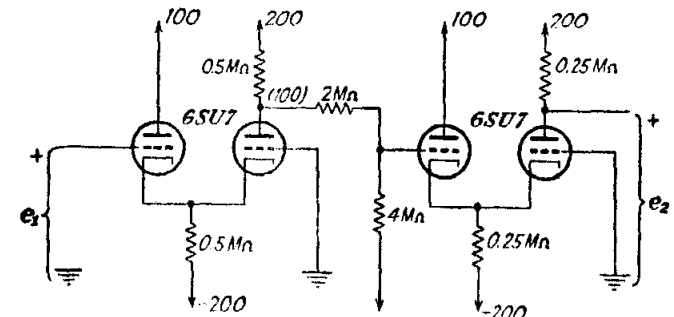

FIG. 4-20. A multistage d-c amplifier employing cathode-coupled amplifiers.

It may be shown that the h-f cutoff value, which results from the effects of the interelectrode, wiring, and distributed capacitances, is considerably higher than in a single-tube amplifier. However, such amplifier stages are not used for broad-band or video amplifiers, since a pentode proves to be superior, both as regards gain and bandwidth possibilities. Moreover, pentodes are seldom used in this circuit from bandwidth considerations alone. Such cathode-coupled amplifiers are used for very l-f or d-c amplifier service.

4-11. H-F Compensation of Video Amplifiers. The untuned potential amplifiers that are discussed in the foregoing sections possess flat frequency-response characteristics over a range of frequencies. Frequently, however, the region of uniform amplification must be wider than is possible with the simple circuits. Also, the question of the phase response becomes quite important in many broad-band amplifiers. Extending the h-f range of an amplifier has received considerable attention, different services requiring different solutions. For example, radar receivers may require a uniform response of 2 to 8 Mc, depending upon the service, although the l-f response in these is not too critical. Television receivers require a sensibly uniform amplification over the range from 30 cps to 4.5 Mc. Such broad-band amplifiers may be achieved by compensating the simple amplifier at both the l-f and the h-f ends of the frequency scale; by the use of tubes as coupling devices, these being connected ordinarily as cathode followers; or by the use of circuits from which the primary cause of the frequency distortion has been eliminated.

4-12. Compensated Broad-band Amplifiers.⁷ It is possible to compensate for the drooping of the frequency-response characteristic of a

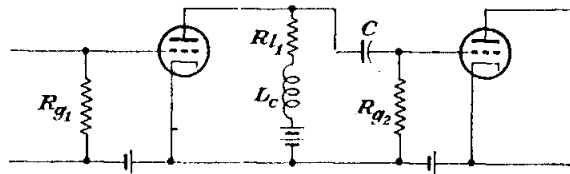

FIG. 4-21. A shunt-peak video amplifier stage.

resistance-capacitance coupled amplifier at both the h-f and the l-f ends of the curve. A number of methods exist for accomplishing these results, and several of the more important of these will be considered below in some detail. However, it is advisable to examine roughly what occurs in these several methods of compensation before undertaking a complete analysis.

In the shunt-peaked method of h-f compensation, an inductor is inserted in series with the load resistor. The circuit has the form illustrated in Fig. 4-21. The inductance L_c is chosen of such a value that it resonates with the total effective capacitance of the output of one tube

and the input of the following tube in the neighborhood of the frequency at which the response would otherwise begin to fall appreciably. In this way, the h-f end of the response curve can be appreciably extended. The choice of the value of L_c is critical; otherwise a peak in the response curve may occur. Such overcompensation must be avoided in most applications.

4-13. H-F Compensation. To study the gain characteristics of an amplifier that is provided with a shunt compensating circuit, the equivalent circuit of Fig. 4-22 is drawn.

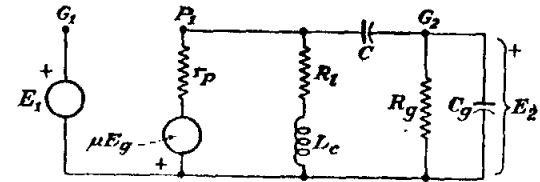

FIG. 4-22. The equivalent circuit of an RC amplifier with an inductor in series with the plate resistor for h-f compensation.

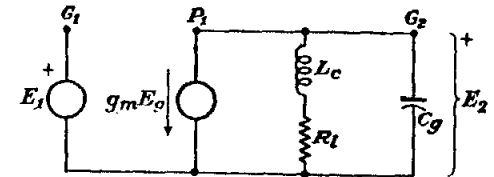

FIG. 4-23. The approximate equivalent circuit of Fig. 4-22 at the mid- and high frequencies.

As the series inductance L_c is small (20 to 50 μ h), its presence does not affect the l-f or the mid-frequency gains of the amplifier. Consequently for this amplifier, Eq. (4-8) for the mid-frequency gain and Eqs. (4-13) and (4-14) for the l-f gain are still valid. These expressions are rewritten here for convenience.

$$K_0 = \frac{-\mu Y_p}{Y_p + Y_l + Y_r} \quad (4-45)$$

$$\frac{K_1}{K_0} = \frac{1}{\sqrt{1 + (f_1/f)^2}} \bigg/ \frac{\tan^{-1} f_1}{f}$$

Broad-band amplifiers usually employ pentodes with relatively small plate-load resistances, as discussed in Sec. 4-7. Because of this, the discussion here will be confined to amplifiers of this type. But for pentodes,

$$r_p \gg R_l \quad R_{g2} \gg R_l \quad (4-46)$$

and the equivalent circuit of Fig. 4-22 reduces to the form of Fig. 4-23. It follows directly from this that the mid-frequency gain is

$$K_0 = -g_m R_l \quad (4-47)$$

and the h-f gain becomes

$$K_2 = \frac{-\mu Y_p}{Y_p + Y_t + Y_{R_o} + Y_{C_o}} \doteq \frac{-g_m}{Y_t + Y_{C_o}} \quad (4-48)$$

The h-f- to mid-frequency-gain ratio is

$$\frac{K_2}{K_0} = \frac{1}{R_t(Y_t + Y_{C_o})} \quad (4-49)$$

Use is made of the quantity f_2 , the half-power frequency without compensation, which is, from Eq. (4-18),

$$f_2 = \frac{Y_p + Y_t + Y_{R_o}}{2\pi C_o} \doteq \frac{1}{2\pi R_t C_o} \quad (4-50)$$

Also, it is convenient to define the quantity Q_2 as

$$Q_2 \equiv \frac{L_c}{R_t^2 C_o} = \frac{\omega_2 L_c}{R_t} \quad (4-51)$$

This is the Q of the series load circuit at the frequency f_2 . Equation (4-49) may then be written in the form

$$\frac{K_2}{K_0} = \frac{1}{1 + j(\omega/\omega_2)Q_2 + j\frac{\omega}{\omega_2}} \quad (4-52)$$

This expression is expanded thus:

$$\frac{K_2}{K_0} = \frac{1 + j(\omega/\omega_2)Q_2}{[1 - (\omega/\omega_2)^2 Q_2^2] + j(\omega/\omega_2)}$$

which may be written as

$$\frac{K_2}{K_0} = \sqrt{\frac{1 + (\omega/\omega_2)^2 Q_2^2}{[1 - (\omega/\omega_2)^2 Q_2^2]^2 + (\omega/\omega_2)^2}} \left/ \tan^{-1} \frac{\omega}{\omega_2} Q_2 - \tan^{-1} \frac{\omega/\omega_2}{1 - (\omega/\omega_2)^2 Q_2^2} \right. \quad (4-53)$$

The significance of this equation is best understood by examining curves of gain and phase shift for various values of Q_2 . A set of gain curves is given in Fig. 4-24.

It is ordinarily desired that the potential gain be practically constant up to a certain designated high frequency. An inspection of Fig. 4-24 shows that this is best achieved by choosing Q_2 to have a value approximately 0.45. Actually the optimum value for Q_2 is found to be 0.414, under which condition $dK/df = d^2K/df^2 = 0$ for the low frequencies. For the optimum value of Q_2 the response curve remains flat without overshoot over the greatest possible frequency range ω/ω_2 and is therefore known as the *maximally flat* response. From Eqs. (4-50) and (4-51)

this requires approximately that

$$R_t = \frac{1}{\omega_2 C_o} \quad (4-54)$$

$$\omega_2 L_c = \frac{R_t}{2}$$

That is, approximately constant gain is achieved when the load resistance is approximately equal to the reactance of the effective shunt capacitance and when the inductive reactance is equal approximately to one-half the load resistance at the frequency ω_2 .

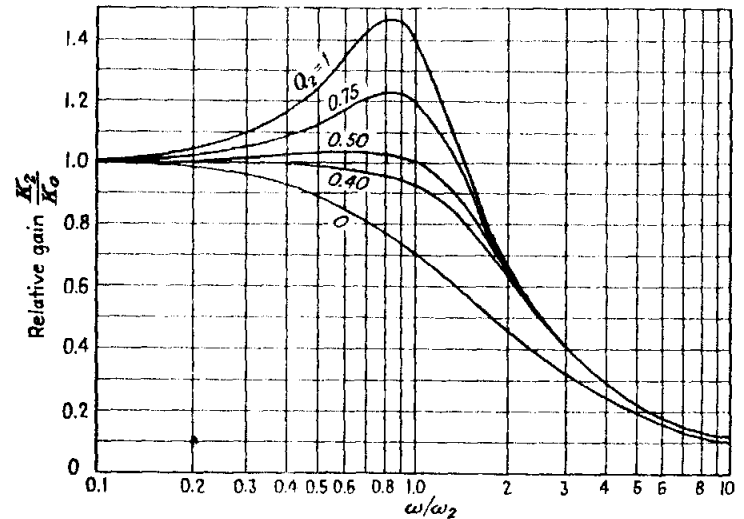

Fig. 4-24. Dimensionless relative-gain curves for the shunt-compensated amplifier. [Adapted from A. V. Bedford and G. L. Fredendall, *Proc. IRE*, 27, 277 (1939).]

In order to preserve the waveform of the signal in an amplifier, not only must the relative amplitudes of the various frequency components be maintained, but also their phase relations must be held constant. If this is not so, then phase distortion results. The phase shift through the amplifier is contained in Eq. (4-53), which is

$$\theta = -\tan^{-1} \frac{\omega}{\omega_2} \left[1 - Q_2 + \left(\frac{\omega Q_2}{\omega_2} \right)^2 \right] \quad (4-55)$$

Evidently, for the waveform to be preserved, either the phase shift of the various components through the amplifier must be zero, or else the phase of all the frequency components must be changed by the same amount in time. In this way the relative phase relations among the harmonics in the waveform will be preserved. A criterion for zero phase distortion is that θ/ω be a constant. A plot of the dimensionless or normalized time delay $\theta\omega_2/2\pi\omega$ vs. ω/ω_2 is contained in Fig. 4-25.

Figure 4-25 shows a family of dimensionless curves which apply to any amplifier. With ω/ω_2 and Q_2 given, the phase shift at any frequency is readily determined. It will be observed that the curve for $Q_2 = 0.33$ appears to show the least variation of θ/ω and so would introduce the least phase distortion or time delay. Actually, by taking the derivative of θ with respect to ω and equating the coefficients for constant delay in the circuit, the optimum value of Q_2 is found to be 0.32. On the other hand, the curve for $Q_2 = 0.414$ yields the least variation in gain. In

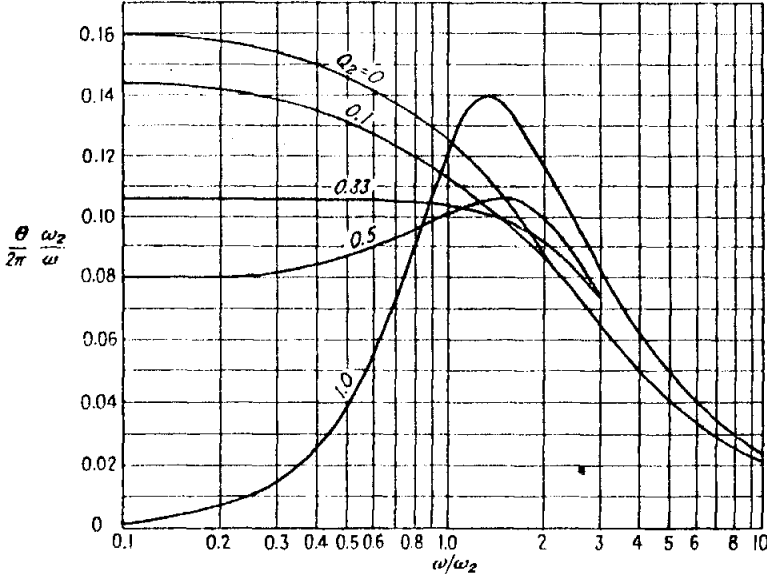

FIG. 4-25. Dimensionless curves of θ/ω as a function of ω/ω_2 for shunt-compensated amplifiers.

general, therefore, it would appear that the value of Q_2 should lie in the range from 0.32 to 0.41. Frequently a value of Q_2 of 0.5 is used, for reasons now to be discussed.

The curve for $Q_2 = 0.5$ yields a relatively uniform amplification over as wide a frequency range as for any value of Q_2 . For this case, the relative gain increases by about 3 per cent ($= 0.3$ db) at $\omega/\omega_2 = 0.70$. This is frequently a tolerable increase if only a few stages are used. Moreover, the time-delay errors of the individual stages are additive and would be tolerable in many applications. If many stages are to be used, then the situation changes. For example, a 10-stage amplifier designed¹ with $Q_2 = 0.50$ would have a 3-db (41 per cent) bump in the gain curve, with a corresponding serious time-delay error. Such characteristics³ might not be tolerable, and a value of Q_2 of 0.41 or lower would then be² used.

Clearly, therefore, the acceptable value of Q_2 will be determined by the maximum allowable variation in gain and the tolerable time-delay error. If one can tolerate the resulting variation in gain, then a given number of stages with $Q_2 = 0.50$ will provide a given gain with a broader bandwidth than is possible with $Q_2 = 0.41$. This means that the requirement for maximum flatness sacrifices bandwidth for a more uniform amplification curve and less time-delay or phase distortion.

It should perhaps be emphasized that the inclusion of an inductance as a compensating network has resulted in a rather remarkable improvement in response. That such a simple correcting network does not provide both optimum gain and constant-phase characteristics for the same conditions should not be surprising or unexpected. More elaborate h-f compensating networks that provide better gain characteristics have been devised. A number of these are discussed later.

4-14. Transient Response of Shunt-peaked Amplifier. Some clarification of the need for a broad frequency-response characteristic is possible by examining the transient-response characteristic of such an amplifier. In particular, suppose that the amplifier is to amplify a narrow pulse, say one that lasts for a microsecond or less. Pulses of this time duration are found in television receivers and also in radar receivers. It is desired to examine and relate the transient-response characteristic with the h-f characteristics of the amplifier.

Consider first the uncompensated amplifier to which a step function of potential is applied. The approximate equivalent circuit, the form of the applied input potential and the form of the output potential are given in Fig. 4-26. If the potential step-function is applied at $t = 0$ when the capacitor is uncharged, the output is easily shown to be

$$e_2 = -\frac{\mu ER_1}{r_p + R_1}(1 - e^{-t/R_1 C_g}) \approx -g_m R_1 E(1 - e^{-t/R_1 C_g}) \quad (4-56)$$

which shows that the output will not follow the applied potential but will approach the steady-state value in the customary exponential manner.

The rise time of such an amplifier is often taken as the time required for

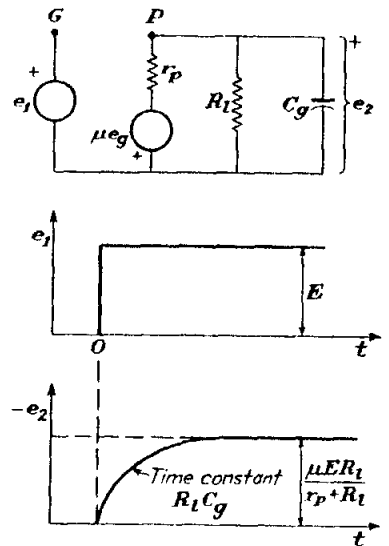

FIG. 4-26. The uncompensated amplifier and its transient response to an input step-function potential.

the amplifier to change from 0.1 of its final value to 0.9 of this value. By inserting these values into Eq. (4-56) and solving for the corresponding value of t , it is found that, at the 0.1 point, the time is $0.1R_1C_g$ and, at the 0.9 point, the time is $2.3R_1C_g$. The rise time is then given by

$$t_{rise} = 2.2R_1C_g = \frac{2.2}{2\pi f_2} = \frac{0.35}{f_2} \quad (4-57)$$

Thus t_{rise} is seen to be inversely proportional to the band pass of the amplifier. Suppose, for example, that f_2 is 1 Mc. It will then require 0.35 μ sec for the potential to rise from 0.1 to 0.9 of its final value. A 1- μ sec pulse will be distorted, but it will retain some semblance of its original form. However, a 0.1- μ sec pulse will be completely distorted if f_2 is only 1 Mc, a value of 10 Mc being required if the same relative shape is required as with a 1- μ sec pulse and a 1-Mc amplifier.

For the case of the shunt-peaked amplifier, the network to be evaluated is that given in Fig. 4-27. The network equations have the operational form

$$\begin{aligned} (r_p + R_1) + L_c p) i_1 - (R_1 + L_c p) i_2 &= -\mu e_1 \\ -(R_1 + L_c p) i_1 + \left(R_1 + L_c p + \frac{1}{C_g p} \right) i_2 &= 0 \end{aligned} \quad (4-58)$$

where p is the symbol for the time derivative operator d/dt . The resulting differential equation relating i_2 with the applied potential e_1 and the network parameters is

$$i_2 = \frac{-\mu(R_1 + L_c p)}{(r_p + R_1 + L_c p) \left(R_1 + L_c p + \frac{1}{C_g p} \right) - (R_1 + L_c p)^2} e_1 \quad (4-59)$$

The output potential is then related to the input potential by the differential equation

$$e_2 = \frac{-\mu(R_1 + L_c p)}{C_g p \left[(r_p + R_1 + L_c p) \left(R_1 + L_c p + \frac{1}{C_g p} \right) - (R_1 + L_c p)^2 \right]} e_1 \quad (4-60)$$

The solution of this equation is somewhat complicated,⁸ the results are best given in graphical form. This is done in Fig. 4-28, which gives the step-function response for various values of Q_2 , for C_g initially uncharged.

The foregoing analysis can be extended to the case of such amplifier stages in cascade. The procedure is straightforward, though the resulting equations are complicated. The results for two identical stages in cascade are given in Fig. 4-29, and the results for three identical stages in cascade are given in Fig. 4-30. It is observed from these sets of curves that the rise time of the amplifier decreases with higher values of Q_2 . However, the fastest rise time with negligible overshoot occurs for the value of Q_2 which gives the most linear-phase characteristic.

The foregoing considerations suggest a simple direct experimental method of obtaining the band pass of an amplifier. The input to the

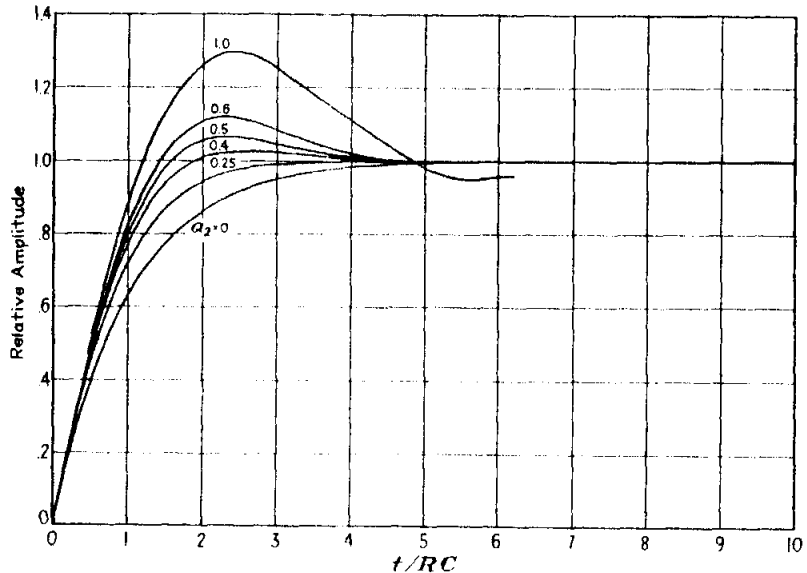

FIG. 4-28. The step-function response of the shunt-peaked amplifier.

amplifier is a square wave, and the output is observed on an oscilloscope. The rise time as herein defined is then measured and is related to the band pass through Eq. (4-57). The square wave is used as a repeating transient source in order to permit sufficient intensity for direct observation on the face of the oscilloscope. Of course, the square wave must have a very small rise time, and the oscilloscope must possess a sufficiently high frequency response compared with the amplifier under test not to influence the results. An accurate sweep calibrator would be used for measuring the rise time.

A number of other methods of compensating the h-f response character of an amplifier exist, some of which are superior to the simple shunt-compensated amplifier discussed in detail. Some of these are illustrated in Fig. 4-31. The transient response of these more elaborate networks is

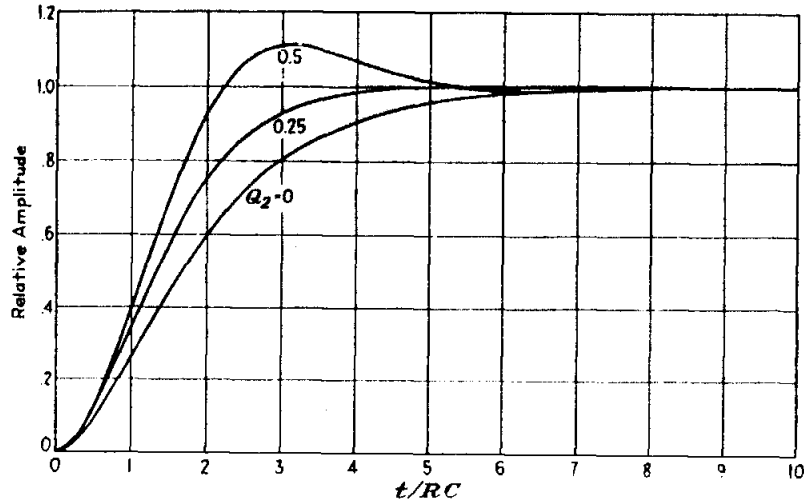

FIG. 4-29. The step-function response of two identical shunt-peaked amplifiers in cascade.

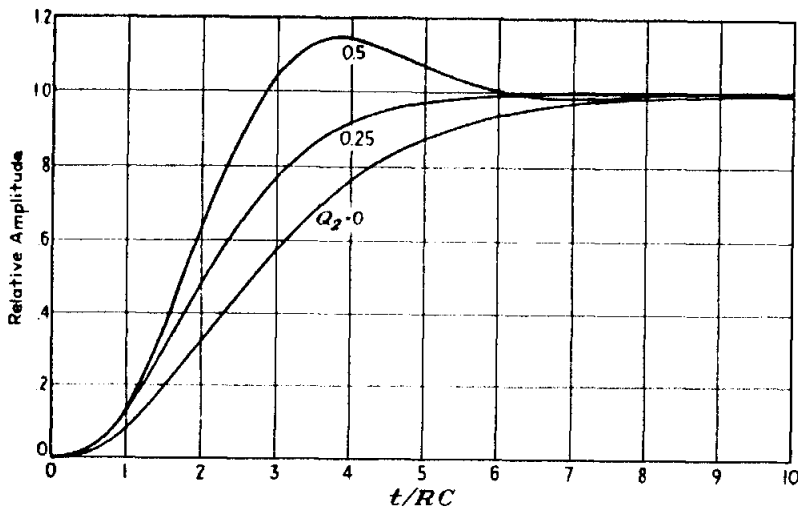

FIG. 4-30. The step-function response of three identical shunt-peaked amplifiers in cascade.

generally not markedly superior to that of the simple shunt-peaking compensation. This results from the fact that the amplification and phase-shift characteristics do not deteriorate so rapidly in the shunt-peaked circuit as in other h-f compensating systems having the same h-f limit. Consequently the apparent advantage of these circuits is largely eliminated. Specifically,⁹ the rise time for the simple shunt-compensated

amplifier of Fig. 4-31a with $L = \frac{1}{4}CR^2$ is $1.57RC$; for the series-compensated amplifier (Fig. 4-31b), with $C_1 + C_2 = C$, $C_1 = C/9$, $C_2 = 8C/9$, $L_1 = 3CR^2/8$, the rise time is $1.40RC$; for the series-shunt compensation of Fig. 4-31c, with $C_1 + C_2 = C$, $C_1 = C/5$, $C_2 = 4C/5$, $L_1 = CR^2/16$, $L_2 = 25CR^2/64$, the rise time is $1.24RC$.

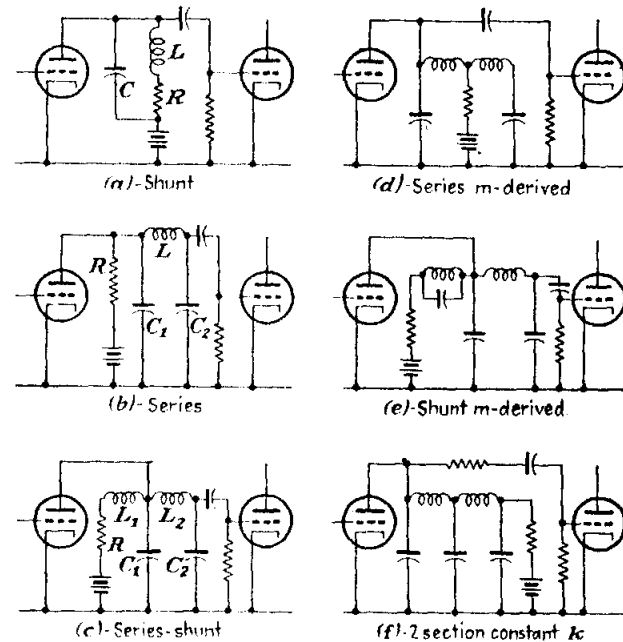

FIG. 4-31. Various h-f compensating coupling circuits. (D. L. Jaffee, *Electronics*, April, 1942.)

4-15. L-F Compensation. The l-f end of the frequency-response curve may be extended by the use of a capacitance across a portion of the load resistance, as illustrated in Fig. 4-32. In this method, the load resistance is effectively R_l at the high frequencies, owing to the shunting action of the capacitance C_c across R_c . At the low frequencies, the shunting effect of C_c is negligible, and the load resistance is effectively $R_l + R_c$. The increased gain of the stage resulting from the increased effective load impedance thus compensates for the loss of gain resulting from the potential-divider action of the coupling capacitor and the grid resistor. In this case, as for the h-f compensation, care must be exercised in the choice of circuit constants.

The equivalent circuit, given in Fig. 4-33, is to be analyzed. Use is again made of the fact that pentodes are generally used in video amplifiers, whence r_p is greater than the combined output load impedance Z .

Also, in general, the grid resistance of the following stage R_g is large compared with the load resistance R_l .

The mid-frequency gain assumes that the reactances of C_c and C are small compared with R_l and R_g , respectively. The gain expression is

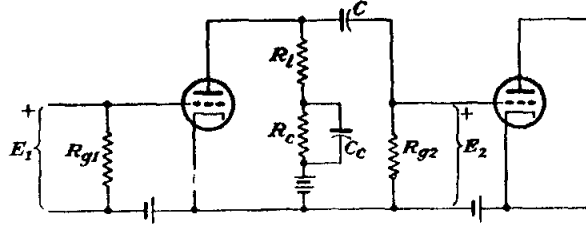

FIG. 4-32. Low-frequency compensation by use of a capacitor across a portion of the load.

then simply

$$K_0 = -g_m R_l \quad (4-61)$$

The l-f gain is readily obtained from an examination of Fig. 4-33. The expression is

$$K_1 = -g_m Z \frac{R_g}{R_g + 1/j\omega C} \quad (4-62)$$

where Z is the total effective impedance of the output network at the low frequencies. By inserting the known value of Z in Eq. (4-62) and

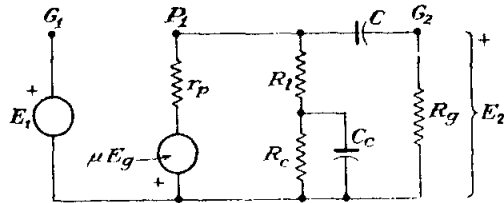

FIG. 4-33. The equivalent circuit of an l-f-compensated RC amplifier.

combining with Eq. (4-61), there results

$$\frac{K_1}{K_0} = R_l \left(\frac{1}{R_l + \frac{1}{\frac{1}{R_c} + j\omega C_c}} + \frac{1}{R_g + \frac{1}{j\omega C}} \right) \frac{R_g}{R_g + \frac{1}{j\omega C}} \quad (4-63)$$

or

$$\frac{K_1}{K_0} = \frac{1}{1 + \frac{1}{R_c + j\omega C_c R_c R_l}} + \frac{j\omega C R_l}{1 + j\omega C R_g} \frac{1}{1 + \frac{1}{j\omega C R_g}}$$

or

$$\frac{K_1}{K_0} = \frac{1}{\frac{R_l + j\omega C_c R_c R_l}{R_l + R_c + j\omega C_c R_c R_l} + \frac{1}{1 + j\omega C R_g} \frac{1}{j\omega C R_g}}$$

which is

$$\frac{K_1}{K_0} = \frac{1}{\frac{R_l}{R_g} + \frac{R_l + j\omega C_c R_c R_l}{R_l + R_c + j\omega C_c R_c R_l} \frac{1 + j\omega C R_g}{j\omega C R_g}} \quad (4-64)$$

But ordinarily the ratio $R_l/R_g \ll 1$, and Eq. (4-64) becomes

$$\frac{K_1}{K_0} = \frac{1}{\frac{R_l}{R_l + R_c} \frac{1 + j\omega C_c R_c}{1 + j\omega C_c \frac{R_c R_l}{R_c + R_l}} \frac{1 + j\omega C R_g}{j\omega C R_g}} \quad (4-65)$$

Three time constants appear in this expression, viz.,

$$C_c R_c, \quad C_c \frac{R_c R_l}{R_c + R_l}, \quad C R_g \quad (4-66)$$

By choosing the parameters such that

$$C R_g = C_c \frac{R_c R_l}{R_c + R_l} \quad (4-67)$$

Eq. (4-65) becomes

$$\frac{K_1}{K_0} = \frac{1}{\frac{R_l}{R_l + R_c} \frac{1 + j\omega C_c R_c}{1 + j\omega C R_g} \frac{1 + j\omega C R_g}{j\omega C R_g}}$$

which is

$$\frac{K_1}{K_0} = \frac{1}{(1 + j\omega C_c R_c)(1/j\omega C_c R_c)} = \frac{1}{1 - j(1/\omega C_c R_c)} \quad (4-68)$$

This may be written in the form

$$\frac{K_1}{K_0} = \frac{1}{\sqrt{1 + (X_{C_c}/R_c)^2}} \angle \tan^{-1} \frac{X_{C_c}}{R_c} \quad (4-69)$$

It is noted that this choice of parameters yields exactly the same form for the l-f response for the compensated case as that of the uncompensated amplifier, and the universal amplification curves may be used if the correct interpretations are made. In the present case the l-f response is controlled by the time constant $R_c C_c$ rather than by the output time constant $R_g C$. The l-f cutoff value now occurs at the value

$$f = \frac{R_l}{R_c + R_l} f_1 \quad (4-70)$$

Hence, the higher the value of R_c , the better the compensation.

If the circuit parameters are not chosen according to Eq. (4-67), over-

compensation or undercompensation may occur, a rise or a fall occurring in the frequency-response characteristic at the low frequencies. The effect of overcompensation is readily manifest in the transient response, the output waveshape for a square-wave input having the rounded out-

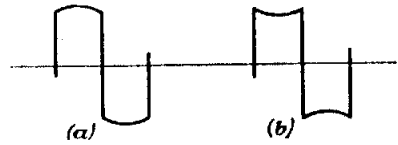

FIG. 4-34. The transient response of an (a) 1-f-overcompensated, (b) 1-f-undercompensated video amplifier.

put shown in Fig. 4-34a. The corresponding effect for undercompensation has the waveform shown in Fig. 4-34b.