

REVISION HISTORY			REVISION APPROVAL			
REV	ECO	DESCRIPTION	PROJECT ENGINEER	APPROVAL DATE	DOCUMENT CONTROL	APPROVAL DATE
F	E10888	SEE ECO FOR HISTORY	RJH	09MAR00	KAH	09MAR00
G	E11008	CHANGE C3 TO LOW ESR TYPE CAP, ADD FLASH SELECT JUMPER JP2, TRACKS A/W @ REV-B	RJH	19APR00	KAH	19APR00
H	E11053	CHANGE U6 FROM 75176B TO SP483EN TO MATCH BOM	RJH	26MAY00	KAH	18MAY00
J	E11182	CHANGE R13 FROM 1K TO 1.3K TO CONFORM WITH UL REGULATIONS ON CURRENT LIMITING RESISTORS				

**TABLE A**

REF DES	DEVICE	DEVICE VOLTAGE INFORMATION					DEVICE: FILTER CAP REF DES(s)
		AGND	GND	VCC	VRAM	NO CONNECTS	
U1	7805T						
U2	LM2575-5.0					2-6.9.11.13.16.19-24	
U3	RABBIT 2000		2,27,39 52,77,89	3,28,53, 78,92	42		C32 - PIN3, C30,31,33,34 C12 - PIN42 (VRAM)
U4	MAX232A		15	16			C14
U5	SRAM		16		32		C15
U6	SP483EN		5	8			C13
U20	LM324	11		4			C21
U21	ETC811						C24
U22	FLASH		24	8			C35

Decoupling Capacitors

- NOTES: UNLESS OTHERWISE SPECIFIED;
- ALL RESISTOR VALUES ARE IN OHMS, 1/10W, 5%
  - ALL CAPACITORS ARE 50VDC OR HIGHER.
  - THE ORIGIN SOURCE OF A VOLTAGE IS REPRESENTED BY (VCC), AND ALL REFERENCES TO THAT VOLTAGE ARE REPRESENTED BY (VCC).
  - OUTLINED CIRCUIT MAY NOT BE STUFFED DEPENDING ON MODEL, SEE STUFFING CHART FOR CLARIFICATION.
  - COMPONENT VALUES SHOWN WITH AN ASTERISK (\*) FOLLOWING THE VALUE, MAY HAVE DIFFERENT VALUES, OR MAY NOT BE STUFFED DEPENDING ON MODEL. SEE STUFFING CHART FOR CLARIFICATION..

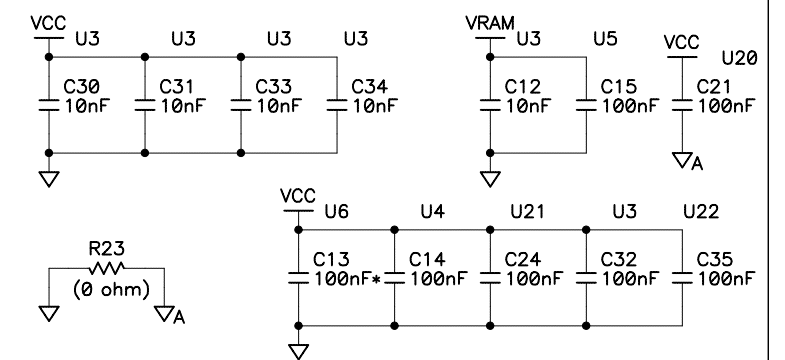

<b>APPEND THE FOLLOWING DOCUMENTS WHEN CHANGING THIS DOCUMENT:</b>	<b>DRAWING CONTENT:</b>		<b>SCHEMATIC DIAGRAM BL1800 SERIES / JACKRABBIT</b>		
	DRAWN BY: (INITIAL RELEASE) JS	27MAY99			
	REVISED BY: KAH	31AUG00	<b>APPROVALS: INITIAL RELEASE</b>		<b>SIZE B</b>
	PROJECT ENGINEER: RJH	21OCT99	DWG NO. 090-0092		
	ENGINEERING MANAGER:		SCALE NONE	RELEASE DATE 21OCT99	SHEET 1 OF 3
	<b>SIGNATURES</b>	<b>DATE</b>			

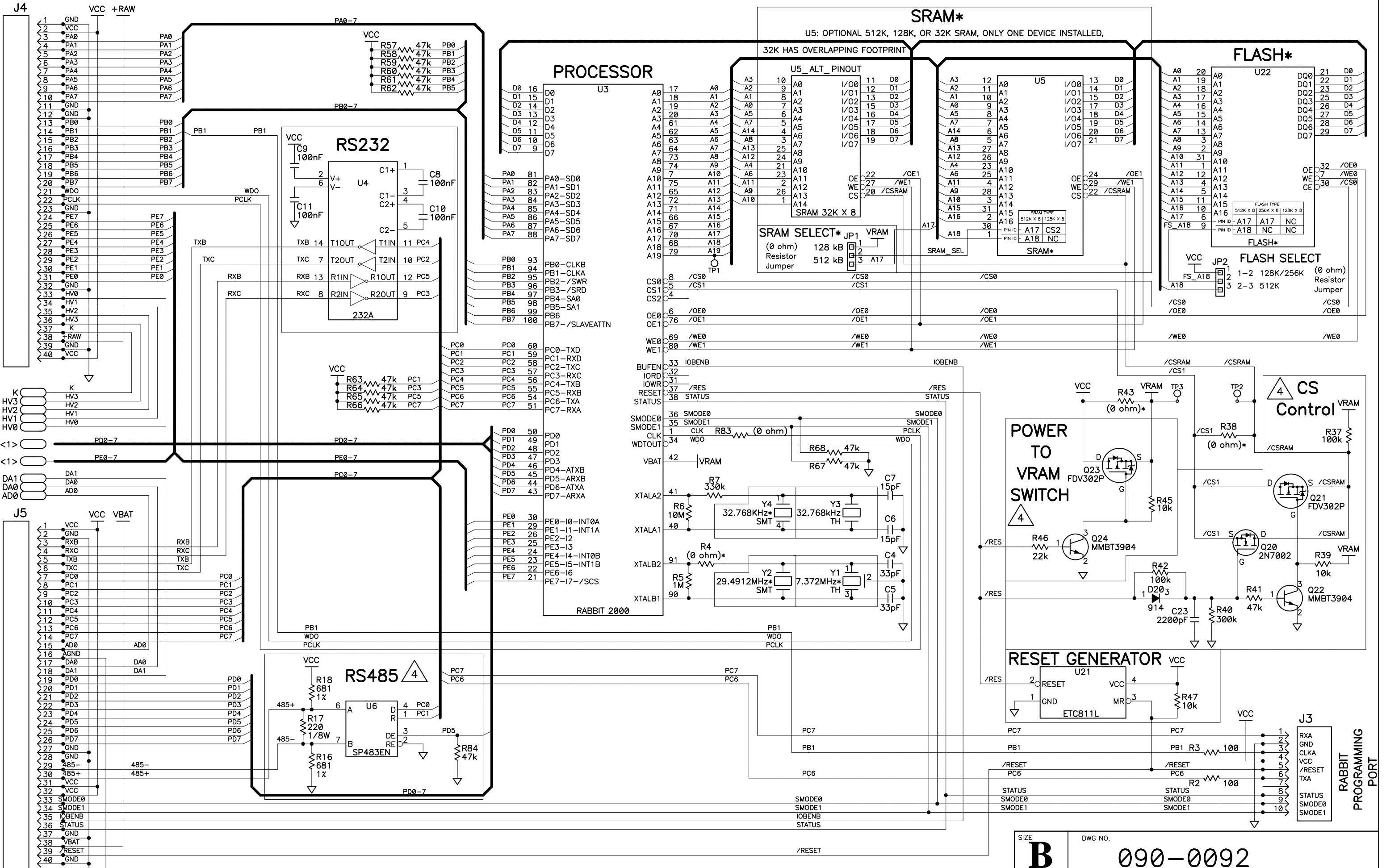

Copyright 2000, Z-World, Inc.

SIZE <b>B</b>	DWG NO. <b>090-0092</b>
SCALE NONE	REV LTR J
SHEET 2 OF 3	

### STUFFING TABLE

CIRCUIT		PART	MODEL				
			BL1800	BL1810	BL1820		
BACKUP BATTERY	MAIN	BT1	3V Li	3V Li	NOT INSTALLED		
		J2	INSTALLED	INSTALLED	NOT INSTALLED		
		R1	100 ohm	100 ohm	NOT INSTALLED		
		R10	4.3M	4.3M	NOT INSTALLED		
		R12	NOT INSTALLED	NOT INSTALLED	NOT INSTALLED		
		R13	1.3k	1.3k	NOT INSTALLED		
	REGULATOR	Q1	5088 npn	5088 npn	NOT INSTALLED		
		R14	220k	220k	NOT INSTALLED		
		R15	2M	2M	NOT INSTALLED		
	REGULATOR TEMPERATURE COMPENSATION ADJUST	D80	NOT INSTALLED	NOT INSTALLED	NOT INSTALLED		
		D81	NOT INSTALLED	NOT INSTALLED	NOT INSTALLED		
		D82	NOT INSTALLED	NOT INSTALLED	NOT INSTALLED		
		R80	ZERO ohm	ZERO ohm	NOT INSTALLED		
		R81	ZERO ohm	ZERO ohm	NOT INSTALLED		
		R82	ZERO ohm	ZERO ohm	NOT INSTALLED		
CHIP SELECT CONTROL	W/BATTERY BACKUP	C23	2200pF	2200pF	NOT INSTALLED		
		D20	914	914	NOT INSTALLED		
		Q20	2N7002 n-ch	2N7002 n-ch	NOT INSTALLED		
		Q21	FDV302P p-ch	FDV302P p-ch	NOT INSTALLED		
		Q22	3904 npn	3904 npn	NOT INSTALLED		
		R37	100k	100k	NOT INSTALLED		
		R39	10k	10k	NOT INSTALLED		
		R40	300k	300k	NOT INSTALLED		
		R41	47k	47k	NOT INSTALLED		
		R42	100k	100k	NOT INSTALLED		
		W/O BATTERY BACKUP	R38	NOT INSTALLED	NOT INSTALLED	ZERO ohm	
		POWER TO VRAM SWITCH	W/BATTERY BACKUP	Q23	FDV302P p-ch	FDV302P p-ch	NOT INSTALLED
				Q24	3904 npn	3904 npn	NOT INSTALLED
	R45			10k	10k	NOT INSTALLED	
R46	22k			22k	NOT INSTALLED		
W/O BATTERY BACKUP	R43		NOT INSTALLED	NOT INSTALLED	ZERO ohm		
POWER SUPPLY	LINEAR	C2	NOT INSTALLED	.1uF	.1uF		
		U1	NOT INSTALLED	7805 LIN REG	7805 LIN REG		
	SWITCHING	C3	330uF	NOT INSTALLED	NOT INSTALLED		
		D1	1N5819	NOT INSTALLED	NOT INSTALLED		
		L1	330uH	NOT INSTALLED	NOT INSTALLED		
U2	LM2575-5.0	NOT INSTALLED	NOT INSTALLED				

CIRCUIT		PART	MODEL		
			BL1800	BL1810	BL1820
SRAM	MAIN	U5	128K SRAM	128K SRAM	128K SRAM
	SRAM SELECT	JP1	ZERO ohm ACROSS PINS 1-2	ZERO ohm ACROSS PINS 1-2	ZERO ohm ACROSS PINS 1-2
FLASH	MAIN	U22	256K FLASH	128K FLASH	128K FLASH
	FLASH SELECT	JP2	ZERO ohm ACROSS PINS 1-2	ZERO ohm ACROSS PINS 1-2	ZERO ohm ACROSS PINS 1-2
RS485	MAIN	C13	.1uF	.1uF	NOT INSTALLED
		R16	681 ohm	681 ohm	NOT INSTALLED
		R17	220 ohm	220 ohm	NOT INSTALLED
		R18	681 ohm	681 ohm	NOT INSTALLED
		R84	47k	47k	NOT INSTALLED
		U6	SP483EN	SP483EN	NOT INSTALLED
D/A CONV	MAIN	C20	47nF	.1uF	.1uF
		C22	47nF	.1uF	.1uF
HIGH POWER DRIVERS	MAIN	Q25	FMMT619	4401 npn	4401 npn
		Q26	FMMT619	4401 npn	4401 npn
		Q27	FMMT619	4401 npn	4401 npn
		Q28	FMMT720	3906 pnp	3906 pnp
		Q29	FMMT619	4401 npn	4401 npn
		HV3=SINKING	D21	NOT INSTALLED	NOT INSTALLED
	R55	NOT INSTALLED	NOT INSTALLED	NOT INSTALLED	
	HV3=SOURCING	R56	ZERO ohm	ZERO ohm	ZERO ohm
	PROCESSOR RTC CRYSTAL	Y3	32.768kHz	32.768kHz	32.768kHz
Y4		NOT INSTALLED	NOT INSTALLED	NOT INSTALLED	
PROCESSOR CRYSTAL	R4	160 ohms	ZERO ohm	ZERO ohm	
	Y1	NOT INSTALLED	7.37MHz Resonator	7.37MHz Resonator	
	Y2	29.49MHz Crystal	NOT INSTALLED	NOT INSTALLED	