

# MICROSTRIP DESIGN TECHNIQUES FOR UHF AMPLIFIERS

Prepared by: Glenn Young

## INTRODUCTION

This note uses a 25 watt UHF amplifier design as a vehicle to discuss microstrip design techniques. The design concentrates on impedance matching and microstrip construction considerations. A basic knowledge of Smith chart techniques is helpful in understanding this note.<sup>1</sup>

The amplifier itself, as shown in Figure 1, provides 25 watts of output power in the 450 – 512 MHz UHF band. It is designed for 12.5 volt operation which makes it useful for mobile transmitting equipment. A variety of police, taxi, trucking and utility maintenance communication systems operate in this band.

A summary of the performance of the completed amplifier operating with a 12.5 volt supply at 512 MHz indicates a

power gain of 16 dB and a bandwidth (– 1 dB) of 8 MHz. Overall efficiency is 48.5% and all harmonics are a minimum of 20 dB below the fundamental output.

Sections on construction and device handling considerations are also presented.

## MICROSTRIP DESIGN CONSIDERATIONS

Microstrip design was used for this amplifier due to its inherent superiority over other methods at this frequency. These techniques not only offer good compatibility with the Motorola “stripline” package but they also offer very good reproducibility. Microstrip construction is more efficient than lumped constant equivalents since microstrip lines are less lossy than lumped constant components.

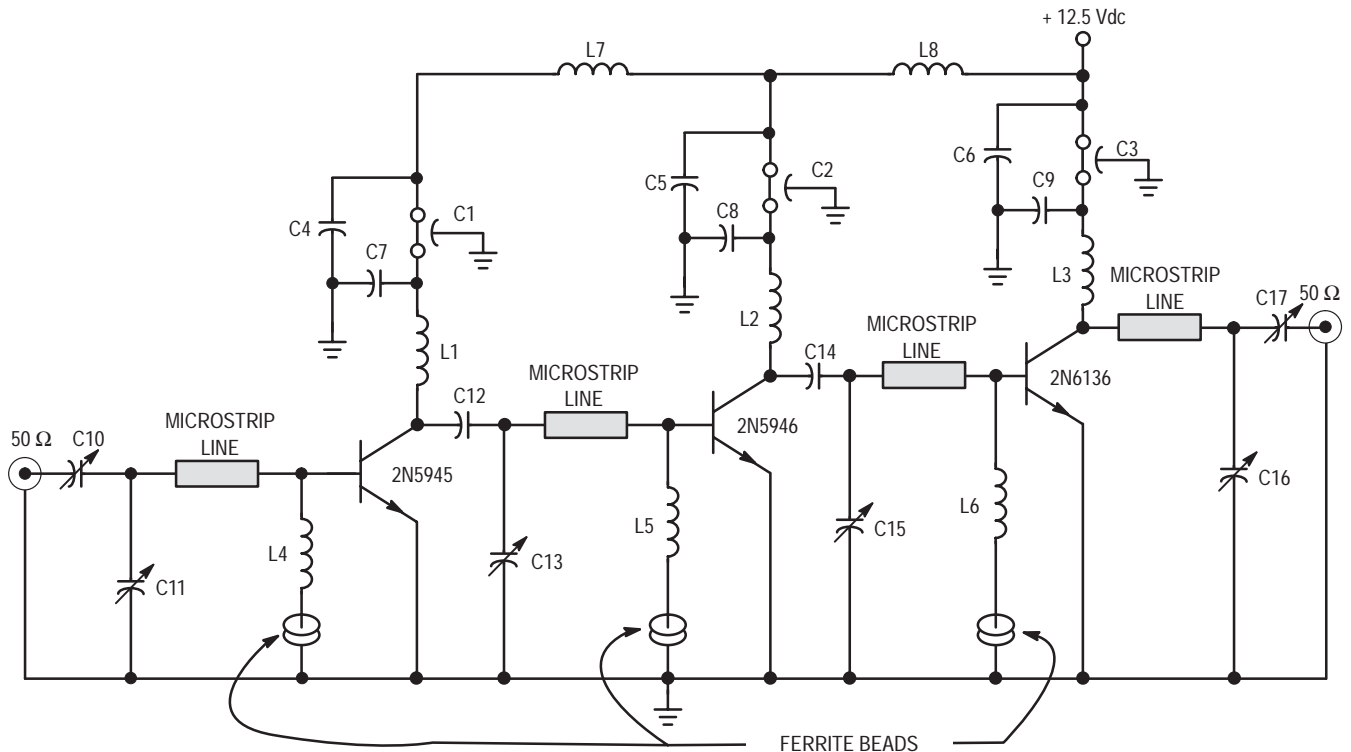

All Microstrip lines 5.72 mm wide 2.5 cm long

C1,2,3 470 pF feedthru

C4,5,6 1.0  $\mu$ F Tantalum

C7,8,9 0.1  $\mu$ F Ceramic

C10,11,13,15,16,17 1.5-20 pF Compression Trimmer ARCO 420

C12,14 10 pF Microwave capacitor ATC type

100-B-10-M-MS or equivalent

L1, L2, L3 – 5 turns #20 Closewound 3/16" I.D.

L4, L5, L6 – 0.15  $\mu$ H molded choke

L7, L8 – Ferroxcube VK 200 20/4B or equivalent

Ferrite beads are Ferroxcube 56 590 65/3B or equivalent

Figure 1. Schematic Diagram of 25 W UHF Amplifier



**MOTOROLA**

Microstrip board with Teflon bonded fiberglass dielectric rather than the higher dielectric constant ceramics was chosen due to the ease of working with that type of material. A substrate thickness of 1/16-inch is convenient since a line of the same width as the transistor leads (0.225 inch) produces a reasonable characteristic impedance ( $Z_0$ ) of 40.65 ohms. The value of the characteristic impedance is calculated from:<sup>4</sup>

$$Z_0 = \frac{377h}{\sqrt{\epsilon_r} \times W \left[ 1 + 1.735 \epsilon_r^{-0.724} \left( \frac{W}{h} \right)^{-0.836} \right]} \quad (1)$$

where  $\epsilon_r$  = dielectric constant  
 $W$  = width of microstrip line  
 $h$  = thickness of the dielectric

The  $h$  term is equal to the total thickness of the microstrip board minus the thickness of the copper on both sides. In this design that term is equal to

$$h = 62 - (2 \times 1.4) = 59.2 \text{ mils} \quad (2)$$

1 oz. copper = 1.4 mils thick

The effective width should be used when the conductor is of finite thickness.

$$W_{\text{eff}} = W + \frac{t}{\pi} \left( \ln \frac{2h}{t} + 1 \right) \quad (3)$$

where  $t$  = thickness of the conductor

$$W_{\text{eff}} = 225 + (1.4/\pi) \left( \ln \frac{2 \times 59.2}{1.4} + 1 \right) = 227.4 \text{ mils} \quad (4)$$

therefore:

$$Z_0 = \frac{377 \times .0592}{\sqrt{2.5} \times .2274 \left[ 1 + 1.735 \times 2.5^{-0.724} \times \left( \frac{227.4}{59.2} \right)^{-0.836} \right]} \quad (5)$$

= 40.65  $\Omega$

### THE AMPLIFIER DESIGN

The first decision in the design was determining the type of matching networks to be used. The network shown in Figure 3 was chosen because of its ability to "map" a large area of complex impedances; this allows a good tuning margin to compensate for normal variations in transistor impedances and other peripheral effects. A side benefit of this network is that the series tuning element provides the dc blocking function, eliminating the need for coupling capacitors.

The synthesis of the matching networks utilizes the large signal impedances of the transistors as specified on the data sheets. These parameters should not be confused with small signal 2-port parameters. A complete discussion of large signal characterization is given in Motorola Application note AN-282A. The impedance parameters used in this note are taken from the respective data sheets and were obtained in the manner described in AN282A.

<b>2N5945</b>	
$Z_{in}$	1.3 + j1.5 ohms
$Z_{out}$	4.6 - j5.4 ohms
<b>2N5946</b>	
$Z_{in}$	1.3 + j1.2 ohms
$Z_{out}$	4.2 - j0.5 ohms
<b>2N6136</b>	
$Z_{in}$	1.3 + j4.11 ohms
$Z_{out}$	3.2 + j1.96 ohms

Figure 2. Transistor Complex Input and Output Impedance at 470 MHz (Series Form)

Smith chart techniques are used to synthesize the matching networks in the amplifier to be described. The complex series equivalent input and output impedances as taken from the data sheets are shown in Figure 2. There are an infinite number of solutions to the required matching networks, however, once an initial choice of one of the components is made, only one solution exists. It is obvious that all components need to be kept within reasonable limits, however it would seem that the most critical parameter is the length of the microstrip line. Using this assumption, the length of the line is chosen as a starting point. The input network, shown in Figure 3 will be solved to illustrate the technique.

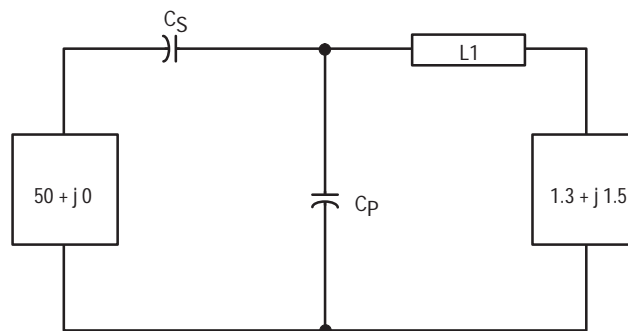

$L_1$  = Microstrip Line 5.72 mm wide 2.5 cm long  
 $C_S$  = 4.08 pF  
 $C_P$  = 16.84 pF

Figure 3. Equivalent Circuit of Input Network

Before proceeding to determine the component values, the effective wavelength of the desired frequency in the microstrip line must be known. This is accomplished by first finding  $\lambda_0$ , the wavelength in free space:

$$\lambda_0 = \frac{c}{\text{freq}} = \frac{3 \times 10^8}{4.7 \times 10^8} = 0.638 \text{ meters} \quad (6)$$

where  $c$  = propagation constant, free space  
 The TEM mode wavelength is determined:

$$\lambda_{\text{TEM}} = \lambda_0 / (\epsilon_r)^{1/2} = 63.8 \text{ cm} / (2.5)^{1/2} = 40.37 \text{ cm} \quad (7)$$

Now as the propagation in microstrip line is not pure TEM mode, a correction factor must be applied to the last calculation.<sup>4</sup>

$$K = \left[ \frac{\epsilon_r}{1 + 0.63 (\epsilon_r - 1) \left( \frac{W}{h} \right)^{.1225}} \right]^{1/2}$$

$$= \left[ \frac{2.5}{1 + 0.63 (2.5 - 1) (227.4/59.2)^{.1225}} \right]^{1/2} = 1.086 \quad (8)$$

Then:

$$\lambda' = (\lambda_{tem}) (K) = (40.37) (1.086) = 43.85 \text{ cm} \quad (9)$$

This is the effective wavelength and will be used in all further calculations. Equation 8 is valid for width to height ratios of 0.6:1 or greater. For ratios less than 0.6:1 alter the (w/h) factor in the denominator to (w/h)<sup>.0297</sup>.

The source and load impedances must now be normalized to the 40.65Ω characteristic impedance of the line and plotted on the Smith chart. It should be noted that the terms "source" and "load" are used here only in reference to the Smith chart solution.

A source impedance of 50 + j0 is normalized to 1.23 + j0 and a load impedance of 1.3 + j1.5 is normalized to 0.032 + j0.0369. The load impedance is plotted at point A in Figure 4 and the source impedance at point F. An arbitrary choice of 2.5 cm for the line length was made. This is an electrical length of:

$$\begin{aligned} \text{electrical length} &= \text{line length}/\lambda' \\ &= 2.5 \text{ cm}/43.85 \text{ cm} = 0.057 \lambda \end{aligned} \quad (10)$$

Point A is rotated on a constant VSWR circle 0.057 λ toward the generator to point B. Reactance must now be added in parallel with the impedance presented at the end of the line just plotted. As parallel additions are more easily handled in admittance form, point B is converted to an admittance by rotating it one-quarter wavelength on the same constant VSWR circle. This results in point C in Figure 4. The constant conductance circle that point C lies on is noted to be 0.23. The problem now is to move along this circle towards the generator until the reciprocal of the constant resistance circle of the source impedance is intercepted. This circle does not exist on a standard Smith chart and must be constructed.

CHART NOT AVAILABLE ELECTRONICALLY

Figure 4. Smith Chart Solution

This is done by determining the radius of the constant resistance circle representing the real part of the source impedance and then constructing a circle of equal radius with its center on the real axis and its circumference tangent to the outer radius of the chart at zero resistance. When this is done the intercept with the 0.23 constant real circle is seen to lie at point D. The amount of parallel susceptance needed to move from point C to point D is:

$$B_{CP} = (B_C - B_D) (Y_0) = (2.4 - 0.38) (24.6) = 49.72 \text{ mmhos} \quad (11)$$

This is a parallel capacitance of:

$$C_P = B_{CP}/2\pi f = 49.72/(2\pi) (470 \times 10^6) = 16.84 \text{ pF} \quad (12)$$

All that remains to finish the solution is to determine the amount of reactance necessary to reach the source at point F. To do this, it is first necessary to transpose point D, which is an admittance, to an impedance. This is accomplished by rotating point D one-quarter wavelength on a constant VSWR circle. This moves point D to point E which is on the 2.04 reactance line thus representing a series reactance of:

$$X_{CS} = (X_E) \cdot (Z_0) = (2.04) \cdot (40.65) = 82.9 \text{ ohms} \quad (13)$$

A series capacitance with this reactance is:

$$C_S = \frac{1}{(2\pi) (f) (X_{CS})} = \frac{1}{(2\pi) (470 \times 10^6) (82.9)} = 4.08 \text{ pF} \quad (14)$$

This completes the solution for the input network.

The interstage networks as well as the output network are solved in similar fashion with the following differences. In the case of the interstage networks when the imaginary term of the source impedance is other than zero, point F would be plotted at the complex conjugate of the source impedance. In the output network solution the "source" is the output load of the amplifier (50 + j0) and the "load" is the collector impedance of the output device.

Figure 5 gives details on the performance of the completed amplifier. The use of the porcelain dielectric chip capacitors for the series elements in the interstage networks was found to provide an additional 2.5 to 3.0 dB of gain over that obtained with compression trimmers as well as reducing the number of tuning adjustments necessary.

	450 MHz	480 MHz	512 MHz
Power Gain	18 db	17.2 db	16 db
Bandwidth (-1 db)	5 MHz	6 MHz	8 MHz
Overall Efficiency	44.5%	46.5%	48.5%
Harmonics	All Harmonics Better Than -20 db		
Stability	Amplifier Stable under all Conditions of Drive Down to V <sub>CC</sub> = 5.0 volts		
Power Output	25 W	25 W	25 W
Burnout	No Damage to any Transistor with Load Open & Shorted with 0 to ± 180° Phase Angle		

Figure 5. Typical Performance Specifications

## CONSTRUCTION CONSIDERATIONS

As in all RF power applications, solid emitter grounds are imperative. In microstrip amplifiers gain can be increased more than 1 dB by grounding both of the emitter leads to the bottom foil of the microstrip board by wrapping strips of copper foil through the transistor mounting hole as shown in Figure 6.

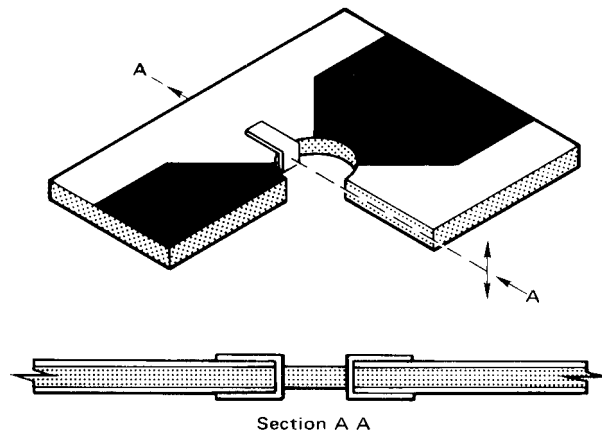

Figure 6. Proper Emitter Grounding Method

Stability under normal operating conditions is essential, however, stability should be maintained over as wide a range of supply voltage and drive levels as possible. If amplifier stability is maintained at all RF drive levels with the supply voltage reduced to between three and five volts, the designer can be practically certain that the amplifier will remain stable under all conditions of load. Maintaining stability is a key factor in protecting these transistors from damage. In a stable amplifier that has adequate heat sinking, these transistors will withstand high VSWR loads including open and shorted loads without damage. The major controlling factors in obtaining wide range stability are:

1) Mechanical layout: Good mechanical layout includes good emitter grounds (as previously described), compact layout and short ground paths.

2) Biasing: The devices are all zero biased for Class "C" operation. The use of relatively low Q base chokes with ferrite beads on the ground side will maintain good base circuit stability. In some applications, the use of a resistor in series with the ground side of the base chokes on the output and driver stages may enhance the stability. Approximate values of these resistors should be 10 ohms, 1/2 watt for the driver and 1.0 ohms, 1/2 watt for the output device. The addition of these series resistors will cause a slight loss in gain; (about 0.1 to 0.2 dB overall).

3) Collector supply feed method: The collector supply feed system is designed to provide decoupling at or near the operating frequency and a low collector load impedance at frequencies much lower than the operating frequency.

4) Heat sinking: In order to protect against burnout under all conditions of load, adequate heat-sinking must be provided. In heat sinking the device it is imperative to use a good grade of thermal compound, such as Dow-Corning 340, on the interface between the device and its heat sink.

Figure 7 shows the microstrip board layout while Figure 8 is a photo of the completed amplifier.

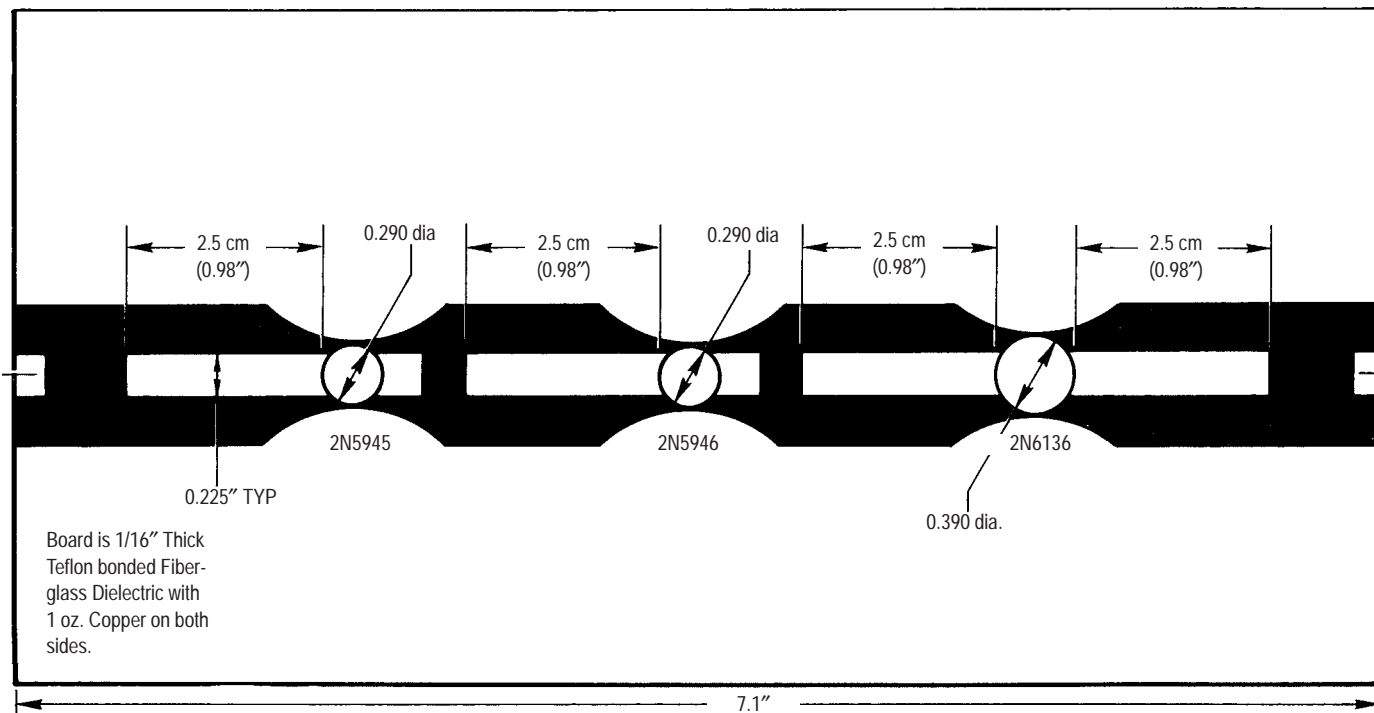

Figure 7. Microstrip Board Layout



Figure 8. Photograph of Amplifier

### DEVICE HANDLING CONSIDERATIONS

Although the Motorola stripline package is a rugged assembly, some care in its handling should be observed. The most important mechanical parameter is stud-torque, specified on the data sheet at 6.5 inch-pounds maximum. This data sheet specification is an absolute maximum and should not be exceeded under any circumstances. A good limit to use in production assembly is 6 inch-pounds and if for any reason repeated assembly/disassembly is required torque should be limited to 5 inch-pounds.

Another major precaution to observe is to avoid upward pressure on the leads near the case body. Stresses of this

type can crack or dislodge the cap. This type stress sometimes occurs due to adverse tolerance build-up in dimensions when the device is mounted through a microstrip board onto a heat sink. Many times this type of stress is applied even in the most carefully thought out designs due to solder build-up on the copper foil when a device is replaced. In device replacement care should be taken to flow all solder away from the mounting area before the stud nut is torqued. Finally, one must be sure to torque the stud nut before soldering the device leads. Refer to Motorola Application Note AN-555 for details on mounting Motorola "stripline packaged transistors."

### REFERENCES

1. P. H. Smith, "Electronic Applications of the Smith Chart", McGraw-Hill, 1969.
2. H. A. Wheeler, "Transmission-Line Properties of Parallel Wide Strips by a Conformal-Mapping Approximation" IEEE Trans. Microwave Theory and Techniques Vol. MTT-12, May 1964.
3. H. A. Wheeler, "Transmission-Line Properties of Parallel Strips Separated by a Dielectric Sheet" IEEE Trans. Microwave Theory and Techniques Vol. MTT-3, March 1965.
4. H. Sobol "Extending Microwave and Technology to Microwave Equipment" Electronics, March 20, 1967.
5. Microwave Engineers Technical and Buyers Guide, Edition of the Microwave Journal, 1969.

Motorola reserves the right to make changes without further notice to any products herein. Motorola makes no warranty, representation or guarantee regarding the suitability of its products for any particular purpose, nor does Motorola assume any liability arising out of the application or use of any product or circuit, and specifically disclaims any and all liability, including without limitation consequential or incidental damages. "Typical" parameters can and do vary in different applications. All operating parameters, including "Typicals" must be validated for each customer application by customer's technical experts. Motorola does not convey any license under its patent rights nor the rights of others. Motorola products are not designed, intended, or authorized for use as components in systems intended for surgical implant into the body, or other applications intended to support or sustain life, or for any other application in which the failure of the Motorola product could create a situation where personal injury or death may occur. Should Buyer purchase or use Motorola products for any such unintended or unauthorized application, Buyer shall indemnify and hold Motorola and its officers, employees, subsidiaries, affiliates, and distributors harmless against all claims, costs, damages, and expenses, and reasonable attorney fees arising out of, directly or indirectly, any claim of personal injury or death associated with such unintended or unauthorized use, even if such claim alleges that Motorola was negligent regarding the design or manufacture of the part. Motorola and  are registered trademarks of Motorola, Inc. Motorola, Inc. is an Equal Opportunity/Affirmative Action Employer.

**Literature Distribution Centers:**

USA: Motorola Literature Distribution; P.O. Box 20912; Phoenix, Arizona 85036.

EUROPE: Motorola Ltd.; European Literature Centre; 88 Tanners Drive, Blakelands, Milton Keynes, MK14 5BP, England.

JAPAN: Nippon Motorola Ltd.; 4-32-1, Nishi-Gotanda, Shinagawa-ku, Tokyo 141, Japan.

ASIA PACIFIC: Motorola Semiconductors H.K. Ltd.; Silicon Harbour Center, No. 2 Dai King Street, Tai Po Industrial Estate, Tai Po, N.T., Hong Kong.

