

Broadband Intermodulation Performance Development Using the Rohde & Schwarz Vector Network Analyzer ZVR

Featuring an RF DTV Broadcast (470 to 860 MHz) Power Application

Prepared by: **Anthony J. Bichler III**
Motorola Semiconductor Products Sector
Phoenix, AZ

ABSTRACT

Historically, broadband linear amplifiers were developed using a technique of tuning and testing intermodulation distortion (IMD) via a two-tone signal at several frequencies within the band. A linear circuit was achieved after several iterations of this tuning using a traditional network analyzer and a spectrum analyzer to sample test the amplifier's IMD performance across the band of interest.

This document presents an innovative system that provides simultaneous broadband swept measurements of gain, input return loss, and two-tone IMD, thus facilitating real-time measurement of key high power RF amplifier design parameters. System theory and configuration are

discussed. Procedures for system setup and calibrations are detailed in the appendices.

INTRODUCTION

This system combines two power-calibrated frequency swept sources. With the ZVR's channels configured to receive the upper and lower IMD products and fundamental frequency independently, two-tone gain and distortion can be visualized in real time. A typical screen shot is shown in Figure 1. Quadrants on the left display input return loss and gain. Quadrants on the right display the upper and lower IMD products.

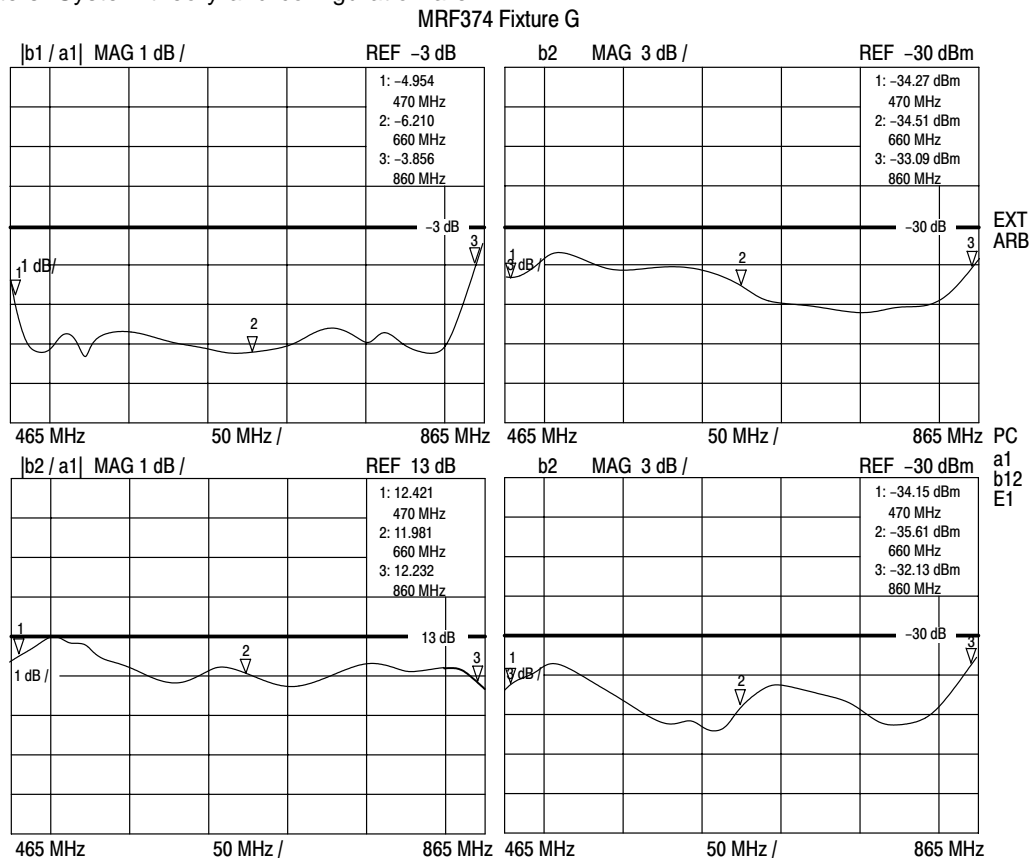

Figure 1. ZVR's Quad Channel Quad Split Display

SYSTEM

Because this system utilizes external power amplifiers for appropriate high power drive levels, the ZVR is placed into external mode. In this mode, the internal source and two receivers are isolated into their three separate ports: a1, b1, and b2, respectively (see Figure 2). With a directional coupler, source plane reflections are received by b1, and thru measurements are made via the b2 receiver.

In the receiver paths, the use of a dc block is essential to avoid accidental damage to the receiver port because the maximum dc port rating is 5 Volts. For the b1 port, the directional coupler provides this dc isolation. The b2 path attenuator does not provide this dc isolation; therefore, the dc block is connected to the b2 port.

The GPIB-TTL controller mode for the external source SMIQ generator requires an additional interface cable of three BNC connectors and a D-connector (see Figure 3). Note that the newer SMIQ "B" models, like the SME generators, do not incorporate the SMIQ AUX IN / OUT interface D-connector. SMIQ "B" and SME TTL interfaces provide TRIG, MRKR, and BLNK in BNC type connectors. In addition, these generators require a fourth BNC coaxial cable. This cable must be

connected from the ZVR's "REF OUT" to the SMIQ's or SME's "REF." In this interface mode, the external source learns a leveled calibrated frequency list that is swept when triggered via TTL. When using two or more display channels for large bandwidths requiring 100 or more measured points, the GPIB-TTL mode is much faster than GPIB alone. The GPIB-only interface mode, however, is sufficient for narrow frequency bands requiring fewer measured points.

EQUIPMENT USED

- Rohde & Schwarz ZVR-62, with options B7, B21, B23, B24, B25, and Firmware V1.61
- Rohde & Schwarz SMIQ-03 Signal Source
- Hewlett Packard 437B Power Meter
- Kalmus 715FC-CE RF 50 W Power Amplifiers
- Alcatel Broadband Circulator (470-860 MHz)
- Anaren 19574-3 Hybrid Coupler / Combiner
- Narda 3020A Directional Coupler
- Micro Lab FXR HR-10N DC Block
- Weinschel 6014 30 dB, 500 W Attenuator
- Motorola MRF374 DTV Application Test Fixture (1)

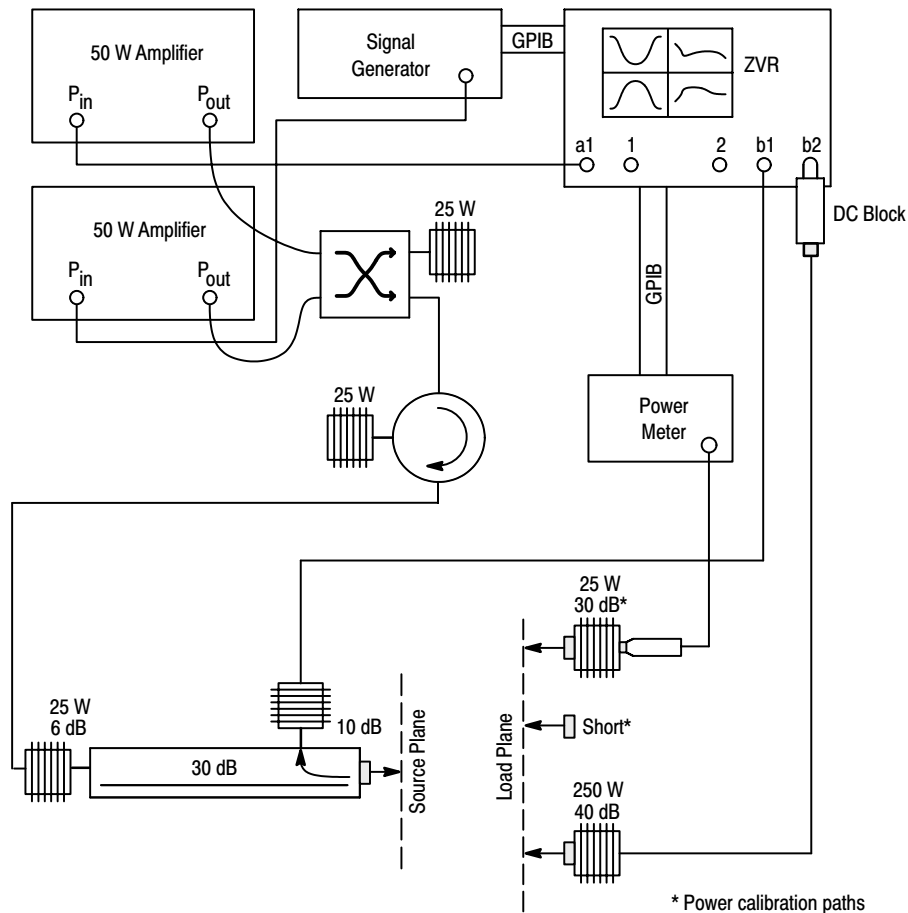

Figure 2. Two-Tone System Diagram

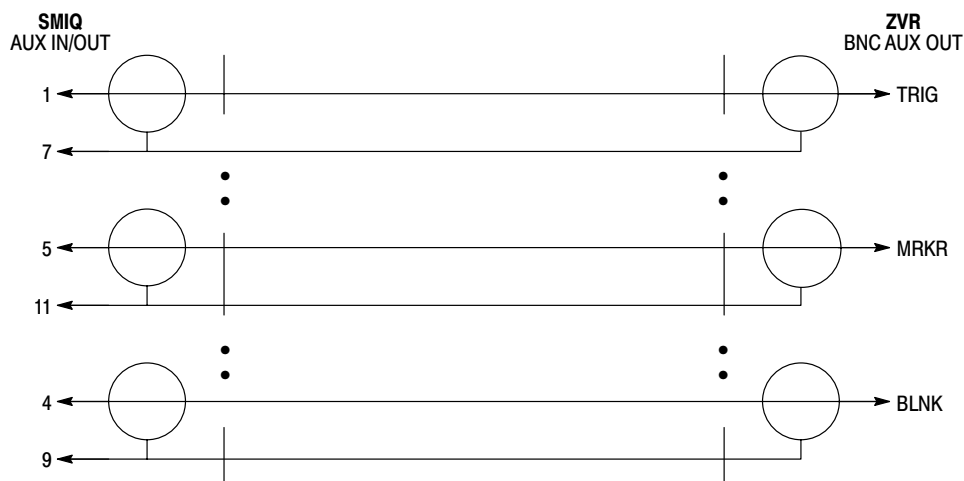

Figure 3. TTL Interface Wiring Diagram for the SMIQ Generator

POWER CALIBRATIONS

Calibration of both internal a1 and external frequency swept sources for amplitude reference and leveling are performed with an external power meter controlled by the ZVR via GPIB interface. The attenuation–padding forward of the external power sensor is user–tabulated into a loss list, under the soft key “EDIT LOSS LIST.” This loss list is used only during source power calibrations that utilize the external power meter.

The source levels during calibration should be approximately that of the expected system application. This reduces any calibration distortions from internal and external source amplifier compression. The desired source plane peak envelope input power for two–tone testing is 6 dB above any single–tone source (see Figure 4). Equal

internal and external source levels combined total a 3 dB increase, and the peak envelope power is twice this level, a total of 6 dB.

During the internal or external source power calibrations, the alternate source is set to a minimum RF level to provide isolation for the independent calibration.

NOTE: During power calibrations, the un–powered hybrid coupler input port should be terminated with the source amplifier in a no RF output, AC powered–on condition. When electrically powered off, the power amplifier presents a different impedance to the hybrid coupler than when it is powered on. Placing the source amplifier in a standby condition may also have the same output impedance deviation as having the amplifier turned off.

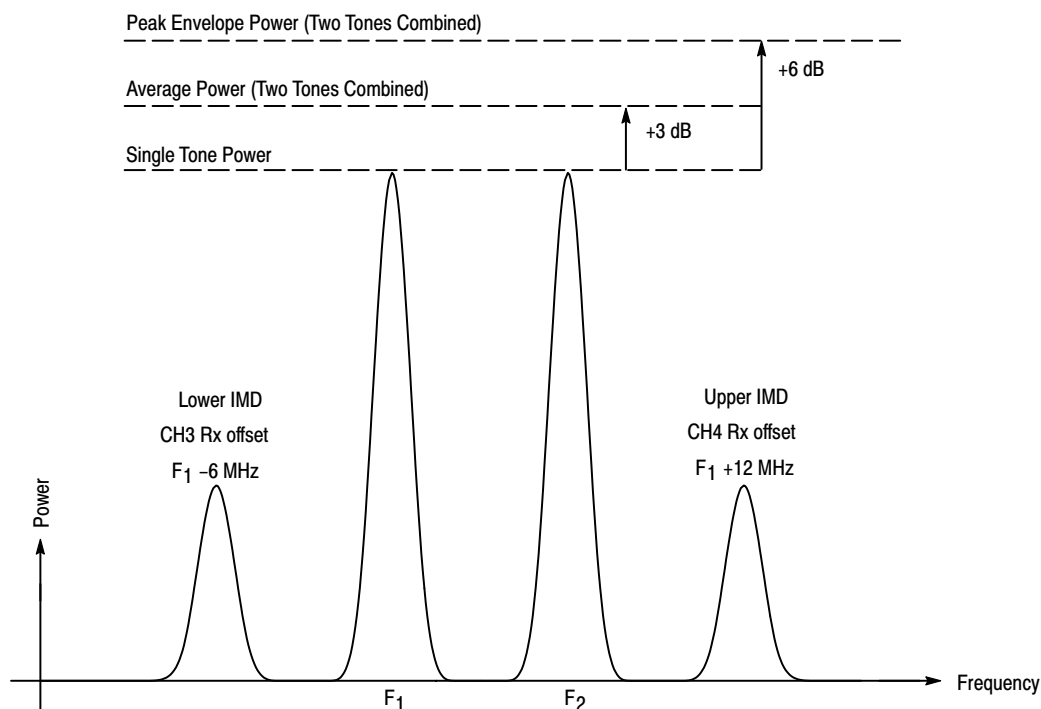

Figure 4. Frequency Conversions Receiver Offsets for Two–Tone, 6 MHz, Third–Order IMD Measurements

The circulator and 6 dB attenuator in Figure 2 should provide a minimum of 20 dB isolation. Without this isolation during b1 power calibration, the reflected source power is re-reflected off the source amplifiers and distorts the calibration measurement. The 6 dB attenuator also provides isolation for harmonics outside of the isolator's bandwidth.

Once the internal source is power calibrated, receivers b1 and b2 are calibrated to the source plane. Receiver b2 is the thru measurement to be used for gain (b2/a1) and IMD measurements. For receiver calibration of b1, a short is used for maximum reflection. Receiver b1 is used for reflected energy/return loss measurements.

For single-tone testing, an additional calibration can be performed that will calibrate the phase for S11 and S21 measurements (see the *Rohde & Schwarz Vector Network Analyzer ZVR Operation Manual*, pp. 12.3x).(2) During two-tone testing (Frequency Conversion Arbitrary Mode), however, this phase calibration is turned off. Arbitrary Mode measurements are in a1, b1, and b2 magnitude or magnitude ratios only.

See the appendixes for procedures on the preceding power calibrations. These procedures should be performed in order, starting with Appendix A.

FREQUENCY CONVERSIONS ARBITRARY MODE

After power calibrations of both sources and receivers, the ZVR is placed in the Arbitrary Mode. Here, both sources and

receivers are independently user-defined for each channel (see Table 1). For example, all four channels have the external source F₂ offset from the internal source F₁ by 6 MHz. Additionally, channels 3 and 4 have their receivers defined for the third-order intermodulation products 2F₂ - F₁ (a 12 MHz offset) and 2F₁ - F₂ (a -6 MHz offset).

For the Arbitrary Mode configuration procedure, see Appendix D.

CONCLUSION

This paper has presented an innovative broadband two-tone measurement system. This system displays gain, input return loss, and IMD swept in real time on a single screen. It is superior to the traditional repetitive tune and test method.

ACKNOWLEDGEMENTS

Thanks to John B. Call, Motorola Semiconductor Products Sector, for his motivation and editorial support.

REFERENCES

- (1) *Motorola Wireless Semiconductor Solutions RF and IF Device Data*, Vol. II (DL110/D, Rev 10), MRF374, pp. 5.2-311-5.2-317.
- (2) *Rohde & Schwarz Vector Network Analyzer ZVR Operation Manual*, 1043.0038.19-10.

BASE FREQUENCY: 465 MHz ... 865 MHz									
FREQ	ON	POWER		NUM		DEN	xB	OFFSET	RESULT
INT SRC	3	30dBm	(1	/	1)xB	=	465 MHz ... 865 MHz
EXT SRC1	3	30dBm	(1	/	1)xB	+6 MHz	= 471 MHz. ... 871 MHz
EXT SRC2									
RECEIVE			(1	/	1)xB	+12 MHz	= 477 MHz ... 877 MHz

Note: Found under the following **key** and soft keys: **MODE**, FREQUENCY CONVERS, DEF ARBITRARY, ARBITRARY SYST FREQ

Table 1. Arbitrary System Frequencies

APPENDIX A POWER CALIBRATION, INTERNAL SOURCE

For the following internal source power calibration, connect the external power meter (HP437B) to the source plane via the

30 dB, 25 W attenuator (see Figure 2). The RF on the external source should be set to a minimum level or is isolated without changing any coupler port impedance.

Table 2. Power Calibration, Internal Source Procedure

Key	Soft Key or Data Entry	Description
PRESET		Starting from a preset condition.
SWEEP	NUMBER OF POINTS: 201	201 or more points provide leveled power calibrations for this bandwidth.
↑		
	COUPLED CHANNELS	Soft key is green when selected. Enhancement display is "CPL."
CH1		Select channel 1.
DISPLAY	SINGLE CHANNEL	For setup simplicity, helps to keep the channels coupled.
FORMAT	MAGNITUDE	Displays format configuration.
MODE	EXTERNAL	Switches from internal test set to external ports a1, b1, and b2. Enhancement display is "EXT."
START	450MHz	The frequency band for power calibration must include the two-tone offset for IMD measurements ($2F_1$)
STOP	900MHz	

APPENDIX B RECEIVER b1 AND b2 POWER CALIBRATIONS

These are magnitude-only calibrations and are performed after the internal source power calibration. Prior to these

receiver calibrations, ensure that the external source level is set to the minimum level or is isolated without changing any coupler port impedance.

Table 3. Receiver b1 and b2 Power Calibrations Procedure

Key	Soft Key or Data Entry	Description
SOURCE	STEP ATT b2: 30dB STEP ATT b1: 10dB	To prevent receiver saturation, set each receiver's attenuation so that it is at least 30 dB under the RF maximum port rating of 20 dBm.
CAL	START NEW POWER CAL CAL b1 POWER	Connect the short to the source plane. For this calibration, it is essential to have good isolation, 20 dB minimum from re-reflections off the source amplifiers.
	TAKE CAL SWEEP	Unlike source power calibrations, the duration of b1 and b2 calibration sweeps only takes about one second. Enhancement display is "b1." Once complete, remove the short from the source plane and connect the b2 path via the load attenuator to the source plane.
	CAL b2 POWER TAKE CAL SWEEP	Once complete, remove the b2 path attenuator from the source plane. Enhancement display is "b12." Continue to Appendix C.

APPENDIX C POWER CALIBRATION, EXTERNAL SOURCE

For the following external source power calibration, connect the external power meter to the source plane via the 30 dB attenuator.

Table 4. Power Calibration, External Source Procedure

Key	Soft Key or Data Entry	Description
SOURCE	STEP ATT a1: 70 dB	Set the RF level on the internal source (a1) to a minimum RF level. This ensures isolation from the internal source.
CAL ⇒	START NEW POWER CAL	
	EXT SRC CONFIG GPIB ADDR: 28 TYPE: SMIQ03 CONNECTION: GPIB	Select the external sources configuration table. Select the correct GPIB address of the external source. Select the external source (SMIQ03) and then select GPIB. Note that the GPIB+TTL is not allowed during power calibrations.
	DEF SRC 1 PCAL SWEEP START: 450MHz STOP: 900MHz NUM OF PTS: 201 SWEEP GRID: LIN	Use arrows to navigate the sweep table. This frequency band must include any receive frequencies that are used in the Arbitrary Mode (i.e., IMD components $2F_1 - F_2$, $2F_2 - F_1$).
↑	CAL EXT SRC1 POWER: 30dBm EDIT POWER LOSS LIST	This level is the external, single-tone source power. Enter the loss offset for the external power meter's 30 dB attenuator. Should be the same from the previous power calibration.
←	USE POWER LOSS LIST	Enable this list. The soft key is green when selected.
	NUMBER OF READINGS: 3 TAKE CAL SWEEP	Number of measurement iterations per calibration point. Initiates the calibration sweep. Once the sweep is complete, disconnect the power sensor / attenuator from the source plane.
SOURCE	STEP ATTN a1: 0 dB	Set the internal source back to 30 dBm. Continue to Appendix D.

**APPENDIX D
FREQUENCY CONVERSIONS, ARBITRARY MODE**

The following procedure sets up a display of magnitude and magnitude ratios. Refer to Appendix E for displaying IMD

products in dBc format or small and large signal simultaneously. Appendix D must be performed prior to Appendix E.

Table 5. Frequency Conversions, Arbitrary Mode Procedure

Key	Soft Key or Data Entry	Description
MODE	FREQUENCY CONVERS DEF ARBITRARY	
START	465MHz	This is the displayed bandwidth as in Figure 1.
STOP	865MHz	
	EXT SRC CONFIG CONNECTION: GPIB+TTL	Note that the GPIB+TTL mode is an option only for SME and SMIQ generators. For other sources, use GPIB only.
	ARBITRARY SYST FREQ	Using the arrow keys to navigate, complete the underlined bold fields in Table 1 as follows:
	EXT SRC1: ON	Place a check mark in the external ON column.
	xB:)xB	Select box for “)xB” in the external source xB box.
	EXT SRC1 OFFSET: 6 MHz	Tone spacing offset, $F_1 - F_2$.
↑	ARBITRARY	ARBITRARY soft key is green when selected. Enhancement display is “E1.” The EXT SRC 1 PWR can be adjusted only in the Arbitrary Mode.
SOURCE		
⇒	CAL EXT SRC1 PWR : 30dBm	
SWEEP	NUMBER OF POINTS: 51	The number of points can be reduced for faster sweep speed with minimal loss of resolution.
↑	COUPLED CHANNELS	Decouple the channels. The soft key should be gray.
DISPLAY	QUAD CHANNEL QUAD SPLIT	Screen display as shown in Figure 1.
CH1		
FORMAT	MAGNITUDE	All four channels should be displayed in magnitude format.
MEASURE	RATIO CONV GAIN b1/Pa1	Return loss measurement configuration. Receiver b1 / Power calibrated a1.
CH2		
FORMAT	MAGNITUDE	
MEASURE	RATIO CONV GAIN b2/Pa1	Measurement configuration for gain. Receiver b2 / Power calibrated a1.
CH3		
FORMAT	MAGNITUDE	
MEASURE	INPUT b2	Measurement configuration for the upper IMD product. Receiver b2 magnitude.

Appendix D, Table 5. Frequency Conversions, Arbitrary Mode Procedure (continued)

Key	Soft Key or Data Entry	Description
MODE	FREQUENCY CONVERS DEF ARBITRARY ARBITRARY SYST FREQ RECEIVE OFFSET: 12 MHz	Set receiver offset to 12 MHz for the upper IMD product ($2F_2 - F_1$). For results of 477–877 MHz.
CH4		
FORMAT	MAGNITUDE	Measurement configuration for the lower IMD product. Receiver b2 magnitude.
MEASURE	INPUT b2	
MODE	FREQUENCY CONVERS	

**APPENDIX E
SMALL AND LARGE SIGNAL IN dBc FORMAT**

This alternative configuration displays small and large signal measurements of output power and distortion in decibels below

carrier (dBc) format. Note that for the dBc distortion measurement, math traces cannot be saved to memory because there is no "MATH TO MEMORY" function. With this configuration, input return loss is not displayed. This procedure should follow completion of Appendix D.

Table 6. Small and Large Signal in dBc Format Procedure

Key	Soft Key or Data Entry	Description
CH2 MEASURE	INPUT b2	Select channel 2 for power out measurement. This magnitude is the reference for the dBc relative measurement.
CH1 MEASURE SOURCE	INPUT b2 CAL a1 POWER: 25 dBm	Select channel 1 for small signal power out measurement. Both internal and external sources are set to the new small signal level.
⇨	CAL EXT SRC1 POWER: 25 dBm	
CH3 SOURCE	CAL a1 POWER: 25 dBm	Select channel 3 for small signal IMD measurement.
⇨	CAL EXT SRC1 POWER: 25 dBm	Both internal and external sources are set to the new small signal level.
MODE	FREQUENCY CONVERS DEF ARBITRARY ARBITRARY SYST FREQ RECEIVE OFFSET: 12 MHz	Set the receiver offset for the upper IMD product ($2F_2 - F_1$) or for the worst distortion product. For results of 477–877 MHz. Refer to Table 1 (ARBITRARY SYST FREQ).
TRACE		
⇨	DEFINE MATH	Displays the "DEFINE MATH" table. Use arrow keys to navigate. Select the table's dropdown menus for selections.
	<u>DATA CH3 / DATA CH1</u> MATH USER DEF	Channel 3 is configured to display the difference of b2 "F ₁ " magnitude data from channel 1 versus b2 "upper IMD product" magnitude data from channel 3.
⇨	SHOW MATH	Enhancement display is "MAT."
CH4 MODE	FREQUENCY CONVERS DEF ARBITRARY ARBITRARY SYST FREQ RECEIVE OFFSET: 12 MHz	Set the receiver offset for the upper IMD product ($2F_2 - F_1$) or for the worst distortion product. For results of 477–877 MHz. Refer to Table 1 (ARBITRARY SYST FREQ).

Appendix E, Table 6. Small and Large Signal in dBc Format Procedure (continued)

Key	Soft Key or Data Entry	Description
TRACE ←	DEFINE MATH <u>DATA CH4 / DATA CH2</u>	Channel 4 is configured to display the difference of b2 "F ₁ " magnitude data from channel 2 versus b2 "upper IMD product" magnitude data from channel 4.
→	MATH USER DEF	
	SHOW MATH	Enhancement display is "MAT."

Motorola reserves the right to make changes without further notice to any products herein. Motorola makes no warranty, representation or guarantee regarding the suitability of its products for any particular purpose, nor does Motorola assume any liability arising out of the application or use of any product or circuit, and specifically disclaims any and all liability, including without limitation consequential or incidental damages. "Typical" parameters which may be provided in Motorola data sheets and/or specifications can and do vary in different applications and actual performance may vary over time. All operating parameters, including "Typicals" must be validated for each customer application by customer's technical experts. Motorola does not convey any license under its patent rights nor the rights of others. Motorola products are not designed, intended, or authorized for use as components in systems intended for surgical implant into the body, or other applications intended to support or sustain life, or for any other application in which the failure of the Motorola product could create a situation where personal injury or death may occur. Should Buyer purchase or use Motorola products for any such unintended or unauthorized application, Buyer shall indemnify and hold Motorola and its officers, employees, subsidiaries, affiliates, and distributors harmless against all claims, costs, damages, and expenses, and reasonable attorney fees arising out of, directly or indirectly, any claim of personal injury or death associated with such unintended or unauthorized use, even if such claim alleges that Motorola was negligent regarding the design or manufacture of the part. Motorola and  are registered trademarks of Motorola, Inc. Motorola, Inc. is an Equal Opportunity/Affirmative Action Employer.

Mfax is a trademark of Motorola, Inc.

How to reach us:

USA/EUROPE/Locations Not Listed: Motorola Literature Distribution;
P.O. Box 5405, Denver, Colorado 80217. 1-303-675-2140 or 1-800-441-2447

JAPAN: Motorola Japan Ltd.; SPD, Strategic Planning Office, 141,
4-32-1 Nishi-Gotanda, Shinagawa-ku, Tokyo, Japan. 81-3-5487-8488

Customer Focus Center: 1-800-521-6274

Mfax™: RMFAX0@email.sps.mot.com – TOUCHTONE 1-602-244-6609
Motorola Fax Back System – US & Canada ONLY 1-800-774-1848
– <http://sps.motorola.com/mfax/>

ASIA/PACIFIC: Motorola Semiconductors H.K. Ltd.; Silicon Harbour Centre,
2, Dai King Street, Tai Po Industrial Estate, Tai Po, N.T., Hong Kong.
852-26668334

HOME PAGE: <http://motorola.com/sps/>

**MOTOROLA**