

# RF LDMOS Power Modules for GSM Base Station Application: Optimum Biasing Circuit

Prepared by: Julie Duclercq and Olivier Lembeye  
Motorola Semiconductor Products Sector  
Toulouse, France

## INTRODUCTION

The performances of RF power amplifiers for base station transceivers results in a tradeoff between linearity, efficiency and gain. This tradeoff leads to an optimum quiescent current. But the following parameters modify this bias point: temperature range (commonly  $-40^{\circ}\text{C}/+85^{\circ}\text{C}$ ), supply voltage and bias voltage variations (commonly  $\pm 5\%$ ) and manufacturing spread. The purpose of this paper is to present a new biasing circuit which minimizes quiescent current variations suitable for LDMOS RF power transistors.

## STANDARD BIASING CIRCUIT

A standard biasing circuit commonly used for Class AB transistors is shown in Figure 1.

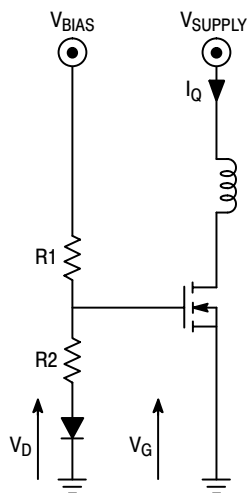

Figure 1. Standard Biasing Circuit

For each LDMOS transistor, it is necessary to adjust the R1 and R2 values in order to set the quiescent current as specified at ambient temperature. Laser-trimmable resistors can be used in mass production for that purpose.

The addition of a diode in series with the two resistors allows for reduction of the quiescent current variation over temperature. We have:

$$V_G = \frac{R_2}{R_1 + R_2} \cdot V_{BIAS} + \frac{R_1}{R_1 + R_2} \cdot V_D \quad (\text{Equation 1})$$

then,

$$dV_G = \frac{R_2}{R_1 + R_2} \cdot dV_{BIAS} + \frac{R_1}{R_1 + R_2} \cdot dV_D \quad (\text{Equation 1.bis})$$

when  $dV_{BIAS} = 0$ , we have:

$$dV_G = \frac{R_1}{R_1 + R_2} \cdot dV_D \quad (\text{Equation 2})$$

Considering variations due to temperature, the coefficient  $\frac{dV_D}{dT}$  to apply to the LDMOS is related to the bias point, i.e., the quiescent current. For class AB biasing, this coefficient is around  $-2\text{mV}/^{\circ}\text{C}$ . For full thermal tracking, more than one diode may be required because of the ratio  $\frac{R_1}{R_1 + R_2}$  in equation 2.

However, this standard biasing circuit presents two major limitations:

**Limitation 1:** the manufacturing spread of threshold voltage leads to a different  $\frac{R_1}{R_1 + R_2}$  ratio for each die. Therefore, all the die is not compensated for in the same way. A die with a high threshold voltage requires a ratio  $\frac{R_1}{R_1 + R_2}$  lower than for a die with a low threshold voltage. Subsequently, the thermal compensation is lower for a die with a high threshold voltage than for a die with a low threshold voltage. This results in quiescent current over or under compensation versus temperature.

**Limitation 2:** equation 1 shows that Bias voltage variations induce proportional gate voltage variations weighed by a ratio  $\frac{R_2}{R_1 + R_2}$ . Thus these gate voltage variations lead to quiescent current variations via the die transconductance.

As a result, we have designed a new biasing circuit to cope with those limitations.

## AN1643

### NEW BIASING CIRCUIT

The new biasing circuit is shown in Figure 2.

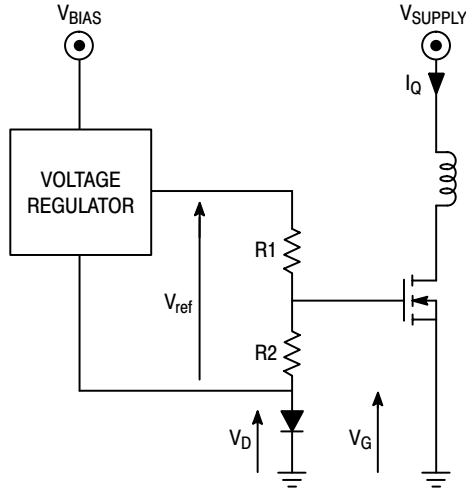

Figure 2. New Biasing Circuit

The bias bridge is adjusted to set the quiescent current as specified at ambient temperature. Laser trimmable resistors can be used in mass production for that purpose.

Thermal tracking is introduced to compensate the quiescent current variations versus temperature. A diode in the bias bridge compensates the LDMOS temperature coefficient. We have now:

$$V_G = \frac{R_2}{R_1 + R_2} \times V_{ref} + V_D \quad (\text{Equation 3})$$

Assuming no reference voltage variation versus bias voltage and temperature ( $dV_{ref} = 0$ ), we have:

$$dV_G = dV_D \quad (\text{Equation 4})$$

*Thermal tracking:* The thermal compensation is now independent of R1 and R2 values and thus independent of the manufacturing spread of transistor's threshold voltage.

*Bias voltage variations:* As the bias voltage is now regulated, we can see from equation 3 that the bias voltage variations are no longer applied on the gate. This results in a constant quiescent current at a given temperature.

Note that in this case the bias voltage can be directly connected to the power supply voltage.

### IMPLEMENTATION

This new biasing circuit is already implemented in three Motorola RF LDMOS power modules designed for GSM base station applications. The MHW910 (10 W GSM900), MHW1810 (10 W GSM1800) and MHW1910 (10 W GSM1900) modules take advantage of this solution.

This new biasing circuit allows keeping this optimum bias point in every temperature and bias voltage combination. One is now able to get the best performances, especially within the whole temperature range.

Another advantage from a customer standpoint is that these new power modules no longer require external bias regulation circuitry for optimum performances.

The voltage regulator used in the MHW910 and MHW1810 is the LP2951. This IC provides the required performances of a very low output voltage temperature coefficient and a very good input voltage variations rejection.

Another feature of the LP2951 is the availability of the shutdown input which allows a logic level signal to turn-off or turn-on the regulator output.

This biasing circuit can be used in the same way for discrete LDMOS transistors as well. Special attention must be taken regarding the DC and RF decoupling.

This circuit guarantees best possible performance by maintaining a constant quiescent current regardless of temperature, bias voltage and gate threshold voltage variations.

Motorola reserves the right to make changes without further notice to any products herein. Motorola makes no warranty, representation or guarantee regarding the suitability of its products for any particular purpose, nor does Motorola assume any liability arising out of the application or use of any product or circuit, and specifically disclaims any and all liability, including without limitation consequential or incidental damages. "Typical" parameters which may be provided in Motorola data sheets and/or specifications can and do vary in different applications and actual performance may vary over time. All operating parameters, including "Typicals" must be validated for each customer application by customer's technical experts. Motorola does not convey any license under its patent rights nor the rights of others. Motorola products are not designed, intended, or authorized for use as components in systems intended for surgical implant into the body, or other applications intended to support or sustain life, or for any other application in which the failure of the Motorola product could create a situation where personal injury or death may occur. Should Buyer purchase or use Motorola products for any such unintended or unauthorized application, Buyer shall indemnify and hold Motorola and its officers, employees, subsidiaries, affiliates, and distributors harmless against all claims, costs, damages, and expenses, and reasonable attorney fees arising out of, directly or indirectly, any claim of personal injury or death associated with such unintended or unauthorized use, even if such claim alleges that Motorola was negligent regarding the design or manufacture of the part. Motorola and  are registered trademarks of Motorola, Inc. Motorola, Inc. is an Equal Opportunity/Affirmative Action Employer.

Mfax is a trademark of Motorola, Inc.

#### How to reach us:

**USA/EUROPE/Locations Not Listed:** Motorola Literature Distribution;  
P.O. Box 5405, Denver, Colorado 80217. 1-303-675-2140 or 1-800-441-2447

**JAPAN:** Motorola Japan Ltd.; SPD, Strategic Planning Office, 141,  
4-32-1 Nishi-Gotanda, Shinagawa-ku, Tokyo, Japan. 81-3-5487-8488

**Customer Focus Center: 1-800-521-6274**

**Mfax™:** RMFAX0@email.sps.mot.com – TOUCHTONE 1-602-244-6609  
Motorola Fax Back System – US & Canada ONLY 1-800-774-1848  
– http://sps.motorola.com/mfax/

**ASIA/PACIFIC:** Motorola Semiconductors H.K. Ltd.; 8B Tai Ping Industrial Park,  
51 Ting Kok Road, Tai Po, N.T., Hong Kong. 852-26629298

**HOME PAGE:** <http://motorola.com/sps/>



**MOTOROLA**



**AN1643/D**