

Offset Reference PLLs for Fine Resolution or Fast Hopping

Prepared by: Morris Smith

INTRODUCTION

Frequency synthesis by use of two loops, with reference frequencies offset from each other, can provide much finer resolution or faster hopping than a single loop. Dual PLL ICs are available to make compact low-current synthesizers using the technique.

Alternative techniques will be discussed, the design method described, and examples provided. This technique has been used successfully with the Motorola MC145220 dual PLL, providing a 64 kHz resolution.

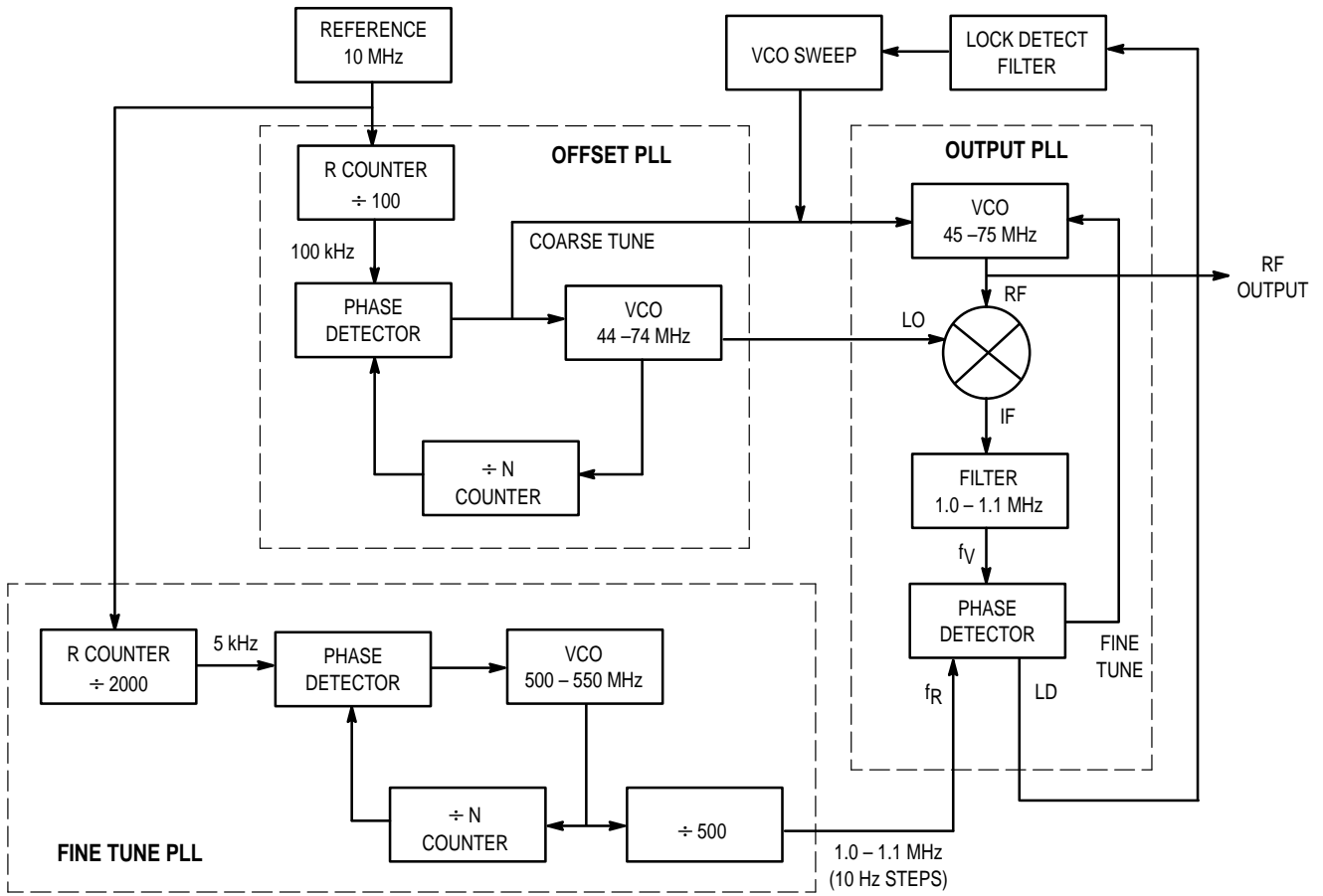

Figure 1. 45 - 75 MHz Triple PLL Synthesizer

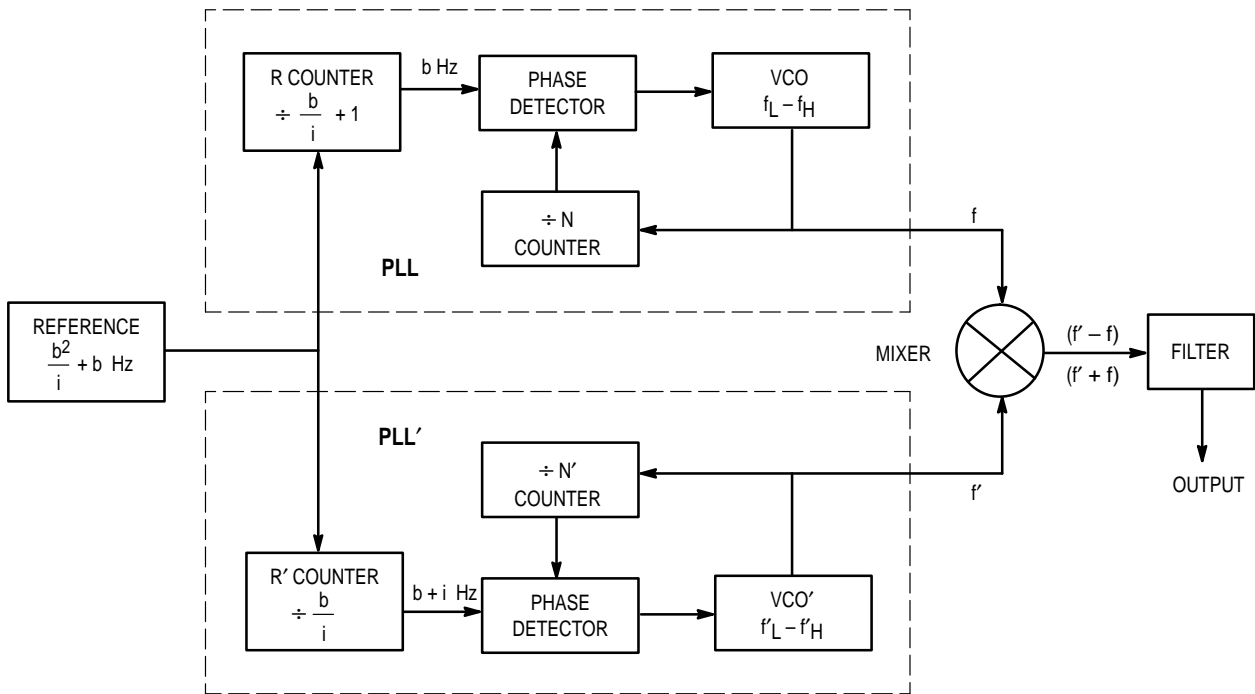

Figure 2. Output Mixed PLLs

COMMON CHARACTERISTICS

Table 1. Variable Definitions

Variable	Definition
b	Step Size of PLL–Base Step Size
i	Step Size of Synthesized Output ($f' - f$), ($f' + f$), or f , Depending on Configuration
b + i	Step Size of PLL'
C	Reference Frequency
$(f' - f)$	Mixer Difference Frequency Output
$(f' + f)$	Mixer Sum Frequency Output
$(f' - f)_L$	Low Frequency Limit of $(f' - f)$
$(f' - f)_H$	High Frequency Limit of $(f' - f)$
$(f' + f)_L$	Low Frequency Limit of $(f' + f)$
$(f' + f)_H$	High Frequency Limit of $(f' + f)$
R, R'	Reference Divider Values
N, N'	PLL, PLL' Feedback Divider Values
N'L, N'H	Lowest and Highest N' Divider Values
N'imax	Number of N' Divider Values Used in Addition to N'L
f, f'	VCO, VCO' Frequency
fL, f'L	VCO, VCO' Lowest Frequency
fH, f'H	VCO, VCO' Highest Frequency

N, N' COUNT SEQUENCE EXCEPT FEEDBACK SUM CONFIGURATION

At any output frequency that is an integer multiple of the base step size (b), $f' = f'_L$. As the output is stepped up in frequency by increment (i), the N' counter is incremented by one in the sequence N'L...N'H. N'H is the counter value one increment (i) below the next output frequency, which is an integer multiple of (b).

Through the N'L...N'H count sequence, N either increments or decrements by one each time the output frequency is stepped up by (i). The term in the output frequency equation which is multiplied by (b) will be held constant. At the same time, the term multiplied by (i) will be increased.

N, N' COUNT SEQUENCE FEEDBACK SUM CONFIGURATION

At any output frequency that is an integer multiple of the base step size (b), $f' = f'_H$. As the output is stepped up in frequency by increment (i), the N' counter decrements by one in the sequence N'H...N'L. N'L is the counter value one increment (i) below the next output frequency, which is an integer multiple of (b).

Through the N'H...N'L count sequence, N decrements by one each time the output frequency is stepped up by (i). The term in the output frequency equation which is multiplied by (b) will be held constant. At the same time, the term multiplied by (i) will be increased.

FORMULA LIMITATIONS

There are a few restrictions on PLL and PLL' frequencies which were made only to simplify the formulas.

Both the output and feedback mixed difference frequency configurations require $f'_L > f_H$ so that as the output increases in frequency, the N' counter value increments.

Output frequency endpoints and either f'_L or f'_H are integer multiples of the base step size (b). This ensures that at the endpoints, VCO' is at f'_L or f'_H . VCO' is also at f'_L or f'_H for any output frequency between the endpoints that can be evenly divided by (b). If the conditions were not met, N' could be anywhere in its count cycle at endpoints. Adding terms to the equations for the two VCO tuning ranges would allow endpoints to be multiples only of the incremental step size (i).

Reference frequency C is given for the lowest frequency that can produce both step sizes by integer division. The R divide value will be one greater than the R' divider. Any reference frequency can be used that is a multiple of the C value from the table.

Since either f'_L or f'_H and C divide by both step sizes, f'_L or f'_H will be an integer multiple of C.

Table 2. Formulas For All Configurations

Variable	Design Equations
C	$C = \frac{b^2}{i} + b$ or $C = \frac{b}{i} (b + i)$
R	$R = \frac{b}{i} + 1$
R'	$R' = \frac{b}{i}$
N'imax	$N'_{imax} = \frac{b}{i} - 1$
N'H	$N'_H = N'_L + N'_{imax}$
f'	$f' = N'(b + i)$
$f'_H - f'_L$	$f'_H - f'_L = \frac{b^2}{i} - i$
f'H	$f'_H = f'_L + \frac{b^2}{i} - i$

OUTPUT MIXED PLLS

Table 3. Output Mixed ($f' - f$) Formulas

Variable	Design Equations
$(f' - f)$	$(f' - f) = b(N' - N) + N'i$
$(f' - f)_L$	$(f' - f)_L = f'_L - f_H + N'_{imax}b$
$(f' - f)_H$	$(f' - f)_H = f'_L - f_L$
f'_L	Any frequency for which $f'_L > f_H$ and f'_L is an integer multiple of C
f	$f = Nb$
f_L	$f_L = f'_L - (f' - f)_H$
f_H	$f_H = f'_L - (f' - f)_L + N'_{imax}b$
$f_H - f_L$	$f_H - f_L = (f' - f)_H - (f' - f)_L + N'_{imax}b$

OUTPUT ($f' - f$) KEY POINTS

- (a) RF output is $(f' - f)$ with $f'_L > f_H$.
- (b) C and f'_L divide evenly by both step sizes.
- (c) f_L , f_H , $(f' - f)_L$, $(f' - f)_H$ divide evenly by b.

OUTPUT ($f' - f$) EXAMPLE

The desired frequency range is 150 – 154 MHz in 0.5 MHz steps using PLLs with 2.0 MHz and 2.5 MHz step sizes.

Reference frequency:

$$C = \frac{b^2}{i} + b = \frac{2^2}{0.5} + 2 = 10 \text{ MHz}$$

The reference divider values are:

$$R = \frac{b}{i} + 1 = \frac{2}{0.5} + 1 = 5$$

$$R' = \frac{b}{i} = \frac{2}{0.5} = 4$$

The number of N' counter values used in addition to N'_L is:

$$N'_{imax} = \frac{b}{i} - 1 = \frac{2}{0.5} - 1 = 3$$

The frequency range of VCO' is:

$$f'_H - f'_L = \frac{b^2}{i} - i = \frac{2^2}{0.5} - 0.5 = 7.5 \text{ MHz}$$

The frequency range of VCO is:

$$\begin{aligned} f_H - f_L &= (f' - f)_H - (f' - f)_L + N'_{imax}b \\ &= 154 - 150 + 3(2) \\ &= 10 \text{ MHz} \end{aligned}$$

f'_L and f_H frequencies depend on each other. To select values, the equation for f_H is solved in terms of f'_L :

$$\begin{aligned} f_H &= f'_L - (f' - f)_L + N'_{imax}b \\ &= f'_L - 150 + 3(2) \\ &= f'_L - 144 \end{aligned}$$

Frequencies used for f'_L and f_H are a tradeoff between phase noise and ease of filtering the mixer products. As f'_L and f_H increase, filtering of mixer products improves. However, the VCO noise increases. The same VCO resonator Q at a higher frequency results in higher noise for the same offset frequency. PLL ICs also produce more noise with increasing frequency.

f'_L of 500 MHz is chosen. The frequency range of VCO' is 500 – 507.5 MHz. The frequency range of VCO is 346 – 356 MHz.

To check results, all divide values and frequencies are in Table 4.

Table 4. Output Mixed ($f' - f$) Example

$(f' - f)$ MHz	N	N'	f MHz	f' MHz
150	175	200	350	500
150.5	176	201	352	502.5
151	177	202	354	505
151.5	178	203	356	507.5
152	174	200	348	500
152.5	175	201	350	502.5
153	176	202	352	505
153.5	177	203	354	507.5
154	173	200	346	500

Table 5. Output Mixed (f' + f) Formulas

Variable	Design Equations
(f' + f)	$(f' + f) = b(N' + N) + N'i$
(f' + f) _L	$(f' + f)_L = f_L + f'_L + N'_{imax}b$
(f' + f) _H	$(f' + f)_H = f_H + f'_L$
f' _L	Any frequency f' _L which is an integer multiple of C
f	$f = Nb$
f _L	$f_L = (f' + f)_L - f'_L - N'_{imax}b$
f _H	$f_H = (f' + f)_H - f'_L$
f _H - f _L	$f_H - f_L = (f' + f)_H - (f' + f)_L + N'_{imax}b$

OUTPUT (f' + f) KEY POINTS

- (a) RF output is (f' + f).
- (b) C and f'_L divide evenly by both step sizes.
- (c) f_L, f_H, (f' + f)_L, (f' + f)_H divide evenly by b.

OUTPUT (f' + f) EXAMPLE

The desired frequency range is 800 – 801 MHz in 125 kHz steps using PLLs with 500 kHz and 625 kHz step sizes.

Reference frequency:

$$C = \frac{b^2}{i} + b = \frac{500^2}{125} + 500 = 2.5 \text{ MHz}$$

The reference divider values are:

$$R = \frac{b}{i} + 1 = \frac{500}{125} + 1 = 5$$

$$R' = \frac{b}{i} = \frac{500}{125} = 4$$

The number of N' counter values used in addition to N'_L is:

$$N'_{imax} = \frac{b}{i} - 1 = \frac{500}{125} - 1 = 3$$

The frequency range of VCO' is:

$$f'_H - f'_L = \frac{b^2}{i} - i = \frac{500^2}{125} - 125 = 1.875 \text{ MHz}$$

The frequency range of VCO is:

$$\begin{aligned} f_H - f_L &= (f' + f)_H - (f' + f)_L + N'_{imax}b \\ &= 801 - 800 + 3(0.5) \\ &= 2.5 \text{ MHz} \end{aligned}$$

f'_L and f_H frequencies depend on each other. To select values, the equation for f_H is solved in terms of f'_L:

$$f_H = (f' + f)_H - f'_L \text{ or } f_H = 801 - f'_L$$

Frequencies used for f'_L and f_H are a tradeoff between phase noise and ease of filtering the undesired mixer products. The best filtering of spurious mixer products occurs if both VCOs are operating at about half the desired output frequency. This increases the frequency separation of the sum and difference products. VCO noise increases with frequency. The same VCO resonator Q at a higher frequency results in higher noise for the same offset frequency. PLL ICs also produce more noise with increasing frequency.

f'_L of 400 MHz is chosen. The frequency range of VCO' is 400 – 401.875 MHz. The frequency range of VCO is 398.5 – 401 MHz.

To check results, all divide values and frequencies are in Table 6.

Table 6. Output Mixed (f' + f) Example

(f' + f) MHz	N	N'	f MHz	f' MHz
800	800	640	400	400
800.125	799	641	399.5	400.625
800.25	798	642	399	401.25
800.375	797	643	398.5	401.875
800.5	801	640	400.5	400
800.625	800	641	400	400.625
800.75	799	642	399.5	401.25
800.875	798	643	399	401.875
801	802	640	401	400

FEEDBACK MIXED PLLS

Table 7. Feedback ($f' - f$) Formulas

Variable	Design Equations
f	$f = b(N' - N) + N'i$
f'_L	Any frequency for which $f'_L > f_H$ and f'_L is an integer multiple of C
$(f' - f)_L$	$(f' - f)_L = f'_L - f_H$
$(f' - f)_H$	$(f' - f)_H = f'_L - f_L + N'_{imax}b$
$(f' - f)_H - (f' - f)_L$	$(f' - f)_H - (f' - f)_L = f_H - f_L + N'_{imax}b$

FEEDBACK ($f' - f$) KEY POINTS

- (a) RF output is f with $f'_L > f_H$.
- (b) C and f'_L divide evenly by both step sizes.
- (c) f_L , f_H , $(f' - f)_L$, $(f' - f)_H$ divide evenly by b .
- (d) Feedback mixer output is $(f' - f)$.

FEEDBACK ($f' - f$) EXAMPLE

The desired frequency range is 63 – 64 MHz in 100 kHz steps using PLLs with 500 kHz and 600 kHz step sizes.

Reference frequency:

$$C = \frac{b^2}{i} + b = \frac{500^2}{100} + 500 = 3 \text{ MHz}$$

The reference divider values are:

$$R = \frac{b}{i} + 1 = \frac{500}{100} + 1 = 6$$

$$R' = \frac{b}{i} = \frac{500}{100} = 5$$

The number of N' counter values used in addition to N'_L is:

$$N'_{imax} = \frac{b}{i} - 1 = \frac{500}{100} - 1 = 4$$

The frequency range of VCO' is:

$$f'_H - f'_L = \frac{b^2}{i} - 1 = \frac{500^2}{100} - 100 = 2.4 \text{ MHz}$$

The frequency range of VCO is the output frequency range, which is 63 – 64 MHz.

f'_L is selected such that $f'_L > f_H$ and f'_L is an integer multiple of C . If the frequency ranges for VCO and VCO' are close together, sum and difference products from the mixer will be further apart and easier to filter.

If both VCOs operate at close to the output frequency, they might overlap. Mixer output could be $(f - f')$ and VCO would be pulled in the wrong direction.

f'_L of 66 MHz is chosen. The frequency range of VCO' is 66 – 68.4 MHz. N counter input frequency range is:

$$\begin{aligned} (f' - f)_L &= f'_L - f_H \\ &= 66 - 64 \\ &= 2 \text{ MHz} \end{aligned}$$

$$\begin{aligned} (f' - f)_H &= f'_L - f_L + N'_{imax}b \\ &= 66 - 63 + 4(0.5) \\ &= 5 \text{ MHz} \end{aligned}$$

To check results, all divide values and frequencies are in Table 8.

Table 8. Feedback ($f' - f$) Example

$(f' - f)$ MHz	N	N'	f MHz	f' MHz
3	6	110	63	66
3.5	7	111	63.1	66.6
4	8	112	63.2	67.2
4.5	9	113	63.3	67.8
5	10	114	63.4	68.4
2.5	5	110	63.5	66
3	6	111	63.6	66.6
3.5	7	112	63.7	67.2
4	8	113	63.8	67.8
4.5	9	114	63.9	68.4
2	4	110	64	66

Table 9. Feedback ($f' + f$) Formulas

Variable	Design Equations
f	$f = b(N - N') - N'i$
f'_H	f'_H is an integer multiple of C
$(f' + f)_L$	$(f' + f)_L = f'_L + f_L + N'_{imax}i$
$(f' + f)_H$	$(f' + f)_H = f_H + f'_H$
$(f' + f)$	$(f' + f) = Nb$

FEEDBACK ($f' + f$) KEY POINTS

- (a) RF output is f .
- (b) C and f'_H divide evenly by both step sizes.
- (c) $f_L, f_H, (f' + f)_L, (f' + f)_H$ divide evenly by b.

FEEDBACK ($f' + f$) EXAMPLE

The desired frequency range is 63 – 64 MHz in 100 kHz steps using PLLs with 500 kHz and 600 kHz step sizes.

Reference frequency:

$$C = \frac{b^2}{i} + b = \frac{500^2}{100} + 500 = 3 \text{ MHz}$$

The reference divider values are:

$$R = \frac{b}{i} + 1 = \frac{500}{100} + 1 = 6$$

$$R' = \frac{b}{i} = \frac{500}{100} = 5$$

The number of N' counter values used in addition to N'_H is:

$$N'_{imax} = \frac{b}{i} - 1 = \frac{500}{100} - 1 = 4$$

The frequency range of VCO' is:

$$f'_H - f'_L = \frac{b^2}{i} - i = \frac{500^2}{100} - 100 = 2.4 \text{ MHz}$$

The frequency range of VCO is the output frequency range, which is 63 – 64 MHz.

f'_H is selected to be an integer multiple of C. If the frequency ranges for VCO and VCO' are close together, sum and difference products from the mixer will be further apart and easier to filter.

f'_H of 66 MHz is chosen. The frequency range of VCO' is 63.6 – 66 MHz.

The frequency limits of the input to the N counter are:

$$\begin{aligned} (f' + f)_L &= f'_L + f_L + N'_{imax}i \\ &= 63.6 + 63 + 4(0.1) \\ &= 127 \text{ MHz} \end{aligned}$$

$$\begin{aligned} (f' + f)_H &= f_H + f'_H \\ &= 64 + 66 \\ &= 130 \text{ MHz} \end{aligned}$$

To check results, all divide values and frequencies are in Table 10.

Table 10. Feedback ($f' + f$) Example

$(f' + f)$ MHz	N	N'	f MHz	f' MHz
129	258	110	63	66
128.5	257	109	63.1	65.4
128	256	108	63.2	64.8
127.5	255	107	63.3	64.2
127	254	106	63.4	63.6
129.5	259	110	63.5	66
129	258	109	63.6	65.4
128.5	257	108	63.7	64.8
128	256	107	63.8	64.2
127.5	255	106	63.9	63.6
130	260	110	64	66

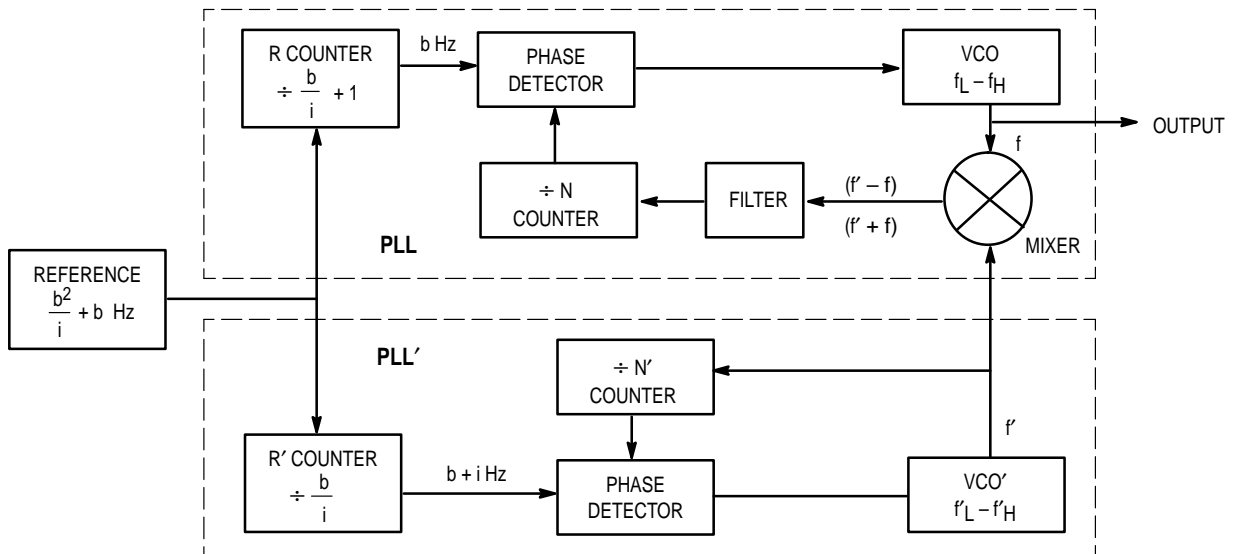

Figure 3. Feedback Mixed PLLs — f Output

DESIGN TRADEOFFS

LIMITATIONS OF FEEDBACK SUM

Feedback sum output causes the N counter to operate at a higher frequency than the desired output. Phase noise within the loop bandwidth could be up to 8 – 9 dB worse than the feedback difference circuit. The worst case for phase noise is the best case for spurious product suppression from the mixer. (Both VCOs operate at about the same frequency.)

OUTPUT MIXED DIFFERENCE

At least one VCO will operate at frequencies above the desired output. This is most useful where the output tuning range is a high percentage of the center frequency. Frequencies of DC – 100 MHz, for example, would be simple to implement in this configuration. If the feature is not needed, phase noise will be higher than necessary.

FEEDBACK DIFFERENCE

This technique results in low phase noise and avoids mixer products being in the output. It works well when both VCOs can tune the ranges needed without range switching. Output mixed sum should also be considered.

OUTPUT MIXED SUM

If the output is between 400 MHz and 800 MHz, it may be better to use two JFET VCOs and sum the outputs. Two bipolar VCOs combined using feedback difference might have higher phase noise. The loops also function independently.

OUTPUT VS. FEEDBACK MIXING

Output mixing allows both PLLs to operate independently. Spurious mixer products will be present on the output. Feedback mixing results in the products being on the PLL input where they will need much less filtering. Also the switching time and damping may depend on both PLLs.

The total number of N' counter values used is:

$$N'_{\text{Total}} = \frac{b}{i}$$

Due to N'_{Total} , it is quite likely that the tuning range of VCO' is much smaller than that of VCO. VCO' would then frequency hop much more quickly. The frequency switching characteristics of PLL using feedback mixing might not be dependent on PLL'.

FREQUENCY RANGE EXTENSION

Both the output mixed sum and feedback mixed difference PLLs can extend the frequency range of the PLL ICs they are used with by approximately two times. Both VCOs would need to be on about the same frequency.

SUMMARY

A series of examples and equations has been described to illustrate a technique that, though not commonly applied, is an elegant way to achieve fine resolution and faster switching.

Offset reference PLLs have become much easier to implement since the introduction of dual loop PLL ICs such as the Motorola MC145220, which operates from 40 MHz – 1.1 GHz. Phase detector and reference divider maximum input frequencies are the major limitation on (b) to (i) ratio.

The MC145220 EVK (Evaluation Kit) implements the output mixed difference technique to achieve 30 ms switching from 60 – 80 MHz. After the switching time has elapsed, the output is within 1 kHz of final frequency. PLL has 10 kHz steps and PLL' has 10.01 kHz steps. Output increment size is 10 Hz. 10 kHz sideband levels are – 80 dB.

ACKNOWLEDGEMENT

1. Jim Irwin of Motorola Semiconductor Products Sector provided many examples of alternative multiple loop schemes.

REFERENCE

2. *Communications Device Data* (DL136/D Rev. 4), page 2–605, Motorola, 1995. Figure 11 is a sample PLL by John Hatchett using the offset reference technique.

Motorola reserves the right to make changes without further notice to any products herein. Motorola makes no warranty, representation or guarantee regarding the suitability of its products for any particular purpose, nor does Motorola assume any liability arising out of the application or use of any product or circuit, and specifically disclaims any and all liability, including without limitation consequential or incidental damages. "Typical" parameters which may be provided in Motorola data sheets and/or specifications can and do vary in different applications and actual performance may vary over time. All operating parameters, including "Typicals" must be validated for each customer application by customer's technical experts. Motorola does not convey any license under its patent rights nor the rights of others. Motorola products are not designed, intended, or authorized for use as components in systems intended for surgical implant into the body, or other applications intended to support or sustain life, or for any other application in which the failure of the Motorola product could create a situation where personal injury or death may occur. Should Buyer purchase or use Motorola products for any such unintended or unauthorized application, Buyer shall indemnify and hold Motorola and its officers, employees, subsidiaries, affiliates, and distributors harmless against all claims, costs, damages, and expenses, and reasonable attorney fees arising out of, directly or indirectly, any claim of personal injury or death associated with such unintended or unauthorized use, even if such claim alleges that Motorola was negligent regarding the design or manufacture of the part. Motorola and  are registered trademarks of Motorola, Inc. Motorola, Inc. is an Equal Opportunity/Affirmative Action Employer.

How to reach us:

USA/EUROPE/Locations Not Listed: Motorola Literature Distribution;
P.O. Box 20912; Phoenix, Arizona 85036. 1-800-441-2447 or 602-303-5454

MFAX: RMFAX0@email.sps.mot.com – TOUCHTONE 602-244-6609
INTERNET: <http://Design-NET.com>

JAPAN: Nippon Motorola Ltd.; Tatsumi-SPD-JLDC, 6F Seibu-Butsuryu-Center,
3-14-2 Tatsumi Koto-Ku, Tokyo 135, Japan. 03-81-3521-8315

ASIA/PACIFIC: Motorola Semiconductors H.K. Ltd.; 8B Tai Ping Industrial Park,
51 Ting Kok Road, Tai Po, N.T., Hong Kong. 852-26629298



AN1277/D

