



## General Description

The PULNiX TM-6705AN is a monochrome full-frame shutter camera which offers double the frame speed of conventional "TV format" cameras. Since the standard mode is double speed, the image can be displayed on a standard VGA monitor. This camera also offers external control variable partial scanning capability with capture rates up to 200fps at 100-line scans. PULNiX PVM multi-sync monitors display all TM-6705AN functions, including partial scanning.

This high resolution square pixel camera has a VGA format interline transfer CCD imager. The signal output is single channel double speed analog progressive scanning (525 lines) at 60 Hz. Asynchronous reset, asynchronous readout control and full-frame integration are standard features.

Images captured in multiple camera applications are stored in each CCD until the readout signal is sent to each individual camera. A single frame grabber and processor can multiplex and process video frames which are taken simultaneously. Consequently, the TM-6705AN can actually replace the use of strobe lights for multiple exposures and in multiple camera applications, in limited and controlled environments.

With its unique capacity for multiple shutter exposures within a frame to capture high speed events, this camera is excellent in applications such as bar code reading, high speed on-line inspection, gauging, character reading, high definition graphics, and motion analysis.

## Applications

- Bar Code Reading
- High Speed On-line Inspections
- Gauging
- Character Reading
- High Definition Graphics
- Motion Analysis

## Single Channel VGA Output

While there are a number of CCD cameras called "VGA", in general only the CCD but not the output is VGA format. The TM-6705AN is true VGA format for both input device (CCD) and output, at 525 lines progressive scan per 60 Hz.

This is achieved with a single channel CCD output circuit so that there is no need for two sets of frame grabbers or memory buffers. This also simplifies the signal processing in the imaging system since the memory mapping can be a straight forward progressive scan format instead of multiple memory buffers. For slow scan or multi scan frame grabbers, **Option 7-2** is provided to output the clock, HD and VD (RS-422, single-ended).

## Product Features

- High resolution 1/2" progressive scanning interline transfer CCD imager 648(H) x 484(V)
- Single channel output VGA progressive scan (525-lines/60Hz), variable partial scan
- Full frame shutter ....1/60 to 1/32,000 sec.
- Asynchronous reset with partial scan control
- Async readout for multi-camera application
- Multiple shutter images per frame
- Full frame integration
- Small, lightweight, ruggedized design
- Replaces strobe lights with electronic shutter

## Asynchronous Reset

The TM-6705AN's asynchronous reset is flexible and takes external horizontal drive (HD) for phase locking. When VINIT pulse is applied, it resets the camera's scanning and purges the CCD. There are five modes to control the asynchronous reset and shutter speed:

- 1. Internal shutter speed with Fast mode.** The shutter speed range is 1/8,000 to 1/32,000 sec. The video signal is captured within 1H from the falling edge of the VINIT.
- 2. Internal shutter speed with Slow mode.** The speed control range is from 1/2,800 to 1/6,000 sec. The camera will discharge at VINIT falling edge if VINIT and external HD falling edges are the same. Output timing delay will depend on the selected shutter timing.
- 3. Asynchronous reset at 0 shutter.** This resets the camera without shutter function. This is useful for conventional strobe applications.
- 4. External VINIT with pulse width control. (Partial scan control)** The duration between pulse edges controls the partial scan period and the fast dump externally.
- 5. Async readout control.** VINIT and ROI (Read Out Inhibit) are used together to control the CCD output for multiple camera applications or multiple exposure functions, to replace strobes. The shutter speed varies by 1H (1/32,000) up to 11H (1/2,800). Although ROI is designed to be asynchronous with VINIT, best results may be achieved by keeping these functions relatively close.

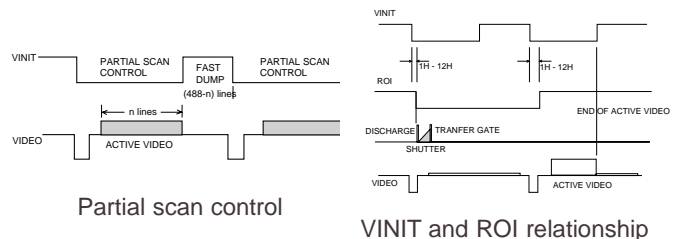

## Asynchronous Readout

The TM-6705AN has a sophisticated timing control for async shutter, readout inhibit and partial scan. Progressive scanning permits a full 484 lines of vertical resolution per single shutter, as compared with a conventional CCD camera at only 244 lines per shutter. The external VINIT resets the camera. The VINIT pulse width controls partial scanning lines to vary the frame rate.

The camera shutter is generated with the ROI (Read Out Inhibit) leading edge. The image is stored in the CCD while ROI is low. When ROI goes to high, the image is scanned for the async readout.

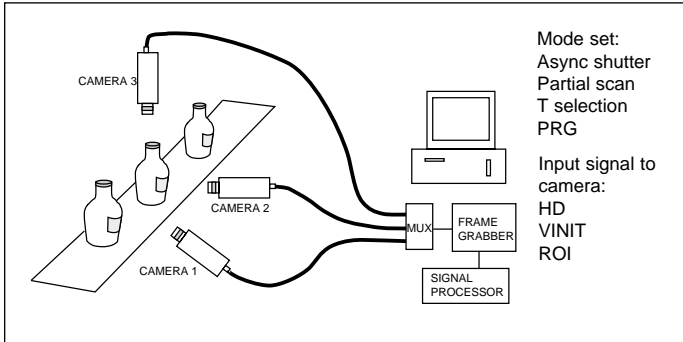

In multiple camera applications for moving objects, all cameras are activated simultaneously. The readout is controlled as time sharing for a single image processor. This is done under continuous lighting conditions. The ROI control is implemented without async shutter. If a strobe light is used as per conventional methods, the async "0" shutter is used for photosite integration.

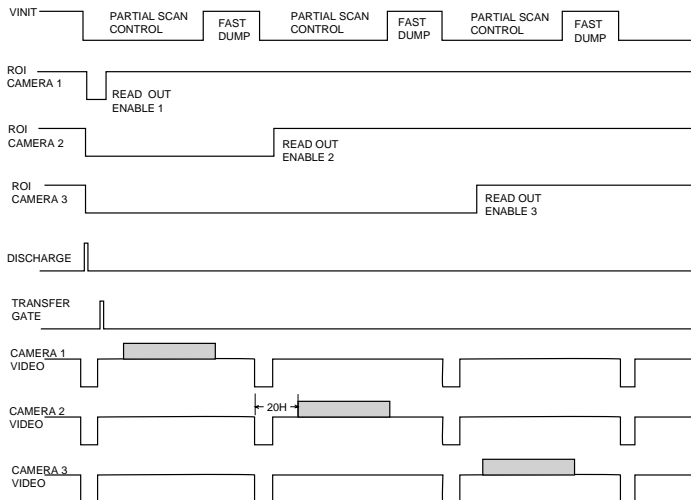

## Multiple Shutter

When ROI is applied to the TM-6705AN (pin #11), the readout is inhibited. During the ROI low, the multiple shutter trigger pulse can be applied (pin #10) to capture the multiple dynamic images in an active frame. This is similar to the multiple exposure techniques of still cameras, or to using multiple strobe lights per single exposure.

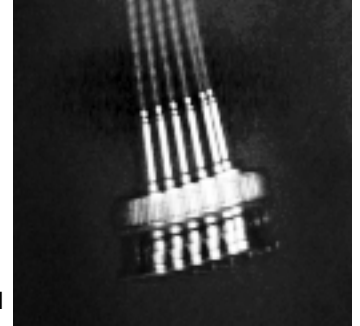

Since the TM-6705AN is a fast frame rate camera with high speed electronic shutter, fast event motion analysis can be achieved with the VINIT partial scan control. As ROI control can be extended to several frame periods, slow speed motion capturing is also possible with normal VGA output.

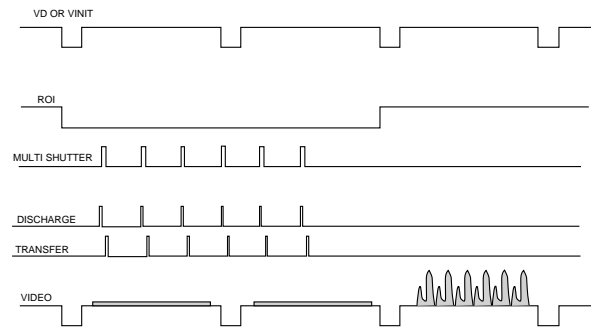

Multi-shutter image capturing

The minimum duration of the multi-shutter control pulse is 2H (64  $\mu$ sec.) and TTL level input. For VGA output format, select Normal, T and ASY, and supply ROI control pulse. For Partial scan, select PART, T and ASY, supply pulse width control VINIT, and ROI. The shutter speed is set by the back panel switch. Since multi-shutter operates with only async mode, the speed is 1H (1/32,000 sec.) through 11H (1/2,800 sec.).

## Partial Scan Mechanism

The TM-6705AN has a unique structure. Because of the fast dump structure and two phase vertical shift register of the CCD, the vertical shift register can be clocked at fast speed while dumping out unnecessary horizontal lines. When the VINIT pulse width control is applied, the vertical shift register is clocked at normal VGA speed (32  $\mu$ sec per line) during VINIT low. When VINIT goes high, the clock rate changes to the maximum speed (2.5  $\mu$ sec per line). At the same time, the fast dump gate opens to eliminate unused charges quickly. The fast dump period is  $[(488-n) \times 2.5\mu\text{sec.}]$ , and stops when all charges are dumped.

For example, if the partial scan is 100 lines, the VINIT must stay low for  $[20H (V_{\text{blank}}) + 100H] = 120 \times 32 \mu\text{sec} = 3.84 \text{ msec.}$  and the fast dump period is  $(488-100) \times 2.5 = 970 \mu\text{sec.}$  The VINIT must stay high for at least 960  $\mu$ sec. before resetting for the next pulse.

## Integration

The CCD imager of the TM-6705AN can be exposed longer than normal TV timing (1/60 sec.). This feature provides high sensitivity for dark environment applications. Integration is achieved by controlling the #11 pin of the 12-pin connector to Low (GND). The progressive scanning CCD chip obtains a full frame of resolution in progressive scan format. A frame grabber is used to capture one frame of integrated image in non-interlace format.

Integration is achieved in the photodiode region of the CCD, which has a built-in dark current suppression structure (hole accumulated layer). However, in long integration the dark noise pattern (white spots) are more visible. The dark noise increases with a rise in temperature (doubles at every 8°C increase).

## Pin Configuration

### 12-pin connector

1 GND	7 VD in/out
2 12V in	8 GND
3 GND	9 HD in/out
4 Video(clock)	10 Multi-shutter
5 GND	11 ROI/Integ**
6 VINIT*	12 GND

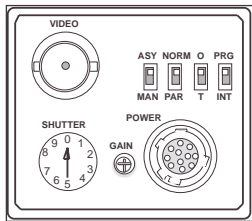

\*Note 1: Pin #6 VINIT is used for partial scan pulse width control

\*\*Note 2: Pin #11 is ROI at ROI control (mode T) and integration at VGA and 0 mode.

### Option 7-2 (Clock and HD, VD output)

For RS-422 output, the clock is output from pin #4 (CLK+) and pin #3 (CLK-). HD+ (#9) and VD+ (#7) are negative common (single ended) and the negative side is GND.

The RS-422 drive is 26LS31. If the termination resistor is high impedance, it may work with TTL input. Please consult PULNiX for more information.

For popular slow scan or multi sync frame grabbers, PULNiX offers Option 7-2. Since each frame grabber has different input connector and control pins, it is advisable to contact either the application personnel for the frame grabber manufacturer or PULNiX application engineers.

## Operation Mode Selection

### Manual Shutter Control

Manual Shutter		Async Reset	
0	no shutter	normal	1/60
1	1/125	1H	1/32,000
2	1/250	2H	1/16,000
3	1/500	3H	1/10,000
4	1/1,000	4H	1/8,000
5	1/2,000	5H	1/6,000
6	1/4,000	6H	1/5,000
7	1/8,000	7H	1/4,500
8	1/16,000	9H	1/3,500
9	1/32,000	11H	1/2,800

### Mode selection switches:

ASY/MAN:	Manual shutter or async shutter
NORM/PAR:	Normal VGA output or partial scan with VINIT pulse width control. In normal mode VINIT pulse width is ignored.
O/T:	Single (O) or multi-camera (T: ROI mode)
PRG/INT:	Progressive only (optional switch)
VGA mode:	<u>O/T</u> , <u>NRM/ASY</u> , shutter 0....Integration
( <u>NORM/PAR</u> )	<u>O/T</u> , <u>NRM/ASY</u> , shutter ...Manual shutter
	<u>O/T</u> , <u>NRM/ASY</u> , shutter 0....Async strobe
	<u>O/T</u> , <u>NRM/ASY</u> , shutter .....Async shutter
	<u>O/T</u> , <u>NRM/ASY</u> , ROI mode..Multi-shutter
	Multi-camera
Partial scan:	<u>O/T</u> , <u>NRM/ASY</u> , shutter 0...Async
( <u>NORM/PAR</u> )	no-shutter
	shutter ....Async shutter
	<u>O/T</u> , <u>NRM/ASY</u> ROI partial scan mode
	Multi-camera, multi-shutter

For async mode, VINIT must be supplied. For ROI mode, ROI pulse must be supplied. For multi-shutter, the shutter control pulse is required.

# Specifications

<b>Imager</b>	1/2" progressive scanning interline transfer CCD
<b>Pixel</b>	648 (H) x 484 (V)
<b>Cell size</b>	9.0 $\mu\text{m}$ x 9.0 $\mu\text{m}$ square pixels
<b>Scanning</b>	60 Hz (double speed) 525 lines non-interlace (VGA output format) Partial scanning (external control with VINIT pulse width)
<b>Sync</b>	Internal/external auto switch HD= 31.468KHz $\pm$ 5% Vertical async. reset or VD=60Hz (non-interlace)
<b>Asynchronous Reset</b>	Ext. Vinit for async reset, ROI control for async readout
<b>Pixel clock</b>	25.49 MHz
<b>TV resolution</b>	500 (H) x 484 (V) lines
<b>S/N ratio</b>	50dB min. (AGC = off)
<b>Min. illumination</b>	2 lux at normal speed
<b>Video output</b>	1.0 Vp-p composite video, 75 $\Omega$ non-interlace
<b>AGC</b>	OFF (AGC ON is a factory option)
<b>Gamma</b>	0.45 or 1.0 (standard)
<b>Electronic shutter</b>	Asynchronous electronic shutter Mode A: 1/32,000 Max. (manual speed selection) Mode B: async speed control (1H to 11H) Full frame resolution per shutter
<b>Lens mount</b>	C-mount
<b>Power req.</b>	12V DC 400 mA
<b>Operating temp.</b>	-10°C to 50°C *
<b>Vibration &amp; shock</b>	Vibration: 7G, Shock: 70G
<b>Size (W x H x L)</b>	46.1mm X 39.2mm X 140.5mm (1.78" x 1.51" x 5.43")
<b>Weight</b>	260 gr (9.2 oz)
<b>Power cable</b>	12P-02
<b>Power supply</b>	K25-12V or PD-12
<b>Auto iris connector</b>	None
<b>Functional options</b>	Op.7-2 for clock, HD and VD output
<b>Accessories</b>	Multi-scan frame grabber cable. Contact PULNiX.

\* NOTE: Image degradation may occur with increasing temperature.

## Dimensions (mm)

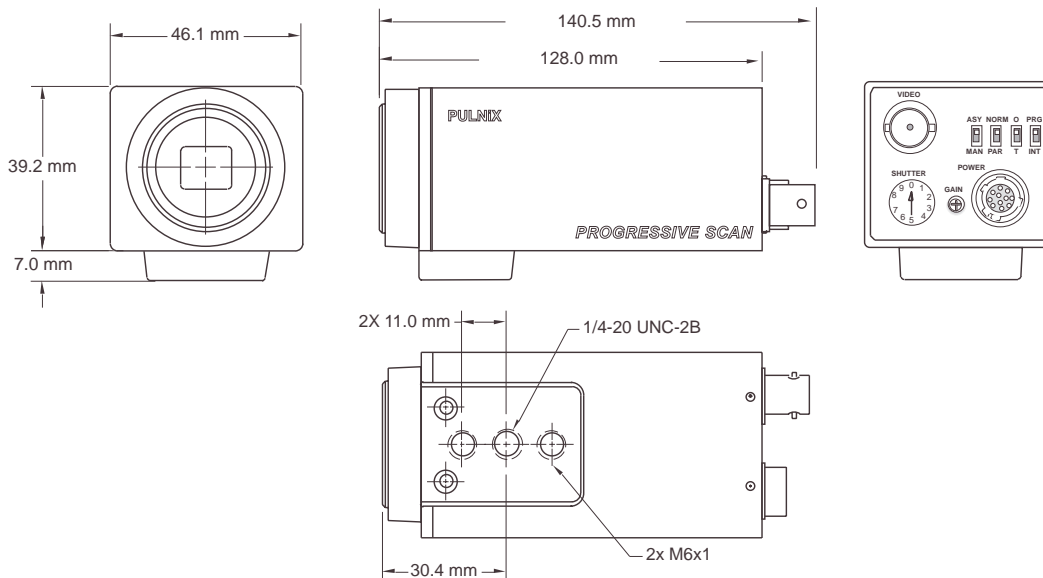

**Japan, Tokyo**  
Ogura Building, 1-11-14 Hongo,  
Bunkyo-ku, Tokyo, 113-033  
Tel: 81-3-5805-2455  
Fax: 81-3-5805-7082  
**Kyoto Office**  
Tel: 81-75-592-2247  
Fax: 81-75-591-2333

**Australia**  
PULNiX America Inc.  
Unit 16, #35 Garden Road  
Clayton, Vic 3168  
Tel: 3-9546-0222  
Fax: 3-9562-4892

**United Kingdom**  
PULNiX Europe Ltd.  
Aviary Court, Wade Road  
Basingstoke, Hants RG24 8PE  
Tel: 01256-475555  
Fax: 01256-466268

**Germany**  
PULNiX Europe Ltd.  
Siemensstrasse 12  
D63755 Alzenau  
Germany  
Tel: 49(0)6023-9625-0  
Fax: 49(0)6023-9625-11

ISO-9001  
Cert. #A39146



**PULNiX**  
Industrial Products Division

PULNiX America Inc. Tel: 408-747-0300  
1330 Orleans Drive Tel: 800-445-5444  
Sunnyvale, CA 94089 Fax: 408-747-0660  
Email: [imaging@pulnix.com](mailto:imaging@pulnix.com)  
[www.pulnix.com](http://www.pulnix.com)

TM-6705AN

71-0022 Rev. A  
Printed: 06/99