

TM-6703 PROGRESSIVE SCAN DOUBLE SPEED SHUTTER CAMERA



General Description

The PULNiX TM-6703 is a high resolution monochrome camera with three scanning modes: non-interlace double speed scanning VGA format (60Hz); two-row scanning (120Hz); and partial scanning (100 and 200 lines). The partial scan image is centered so that there is no dislocation of the object in the field of view when the mode is selected from full field of view to partial scan.

Since the double speed mode is standard, images can be displayed on a standard VGA monitor. PULNiX PVM multi-sync monitors can display all functions including partial scanning.

The full frame electronic shutter with asynchronous reset permits shutter speeds to 1/32,000 sec. The shutter function works in all scanning modes. The signal is analog progressive scanning (525 lines). Optional features include AGC enable, internal IR cut filter, gamma adjust to 0.45, and remoted imagers.

This camera is excellent in applications such as bar code reading, high speed on-line inspection, gauging, character reading, high definition graphics, intensified CCD cameras, and fast speed surveillance. For scientific applications, the Peltier cooling option provides 30°C of cooling for up to 20 minutes of integration.

Electronic Shutter

The TM-6703 has a substrate drain electronic shutter which produces a superb picture at various speeds without smearing. The built-in manual shutter speed control selects the electronic shutter rate of 1/125, 1/250, 1/500, 1/1,000, 1/2,000, 1/4,000, 1/8,000, 1/16,000, or 1/32,000 sec. All shutter speeds are applied to double speed (60Hz), 120 Hz two-row scan (two scanning rows combined), and partial scan except slow speed at partial scanning. Progressive scanning allows a full 484 lines of vertical resolution per single shutter, unlike a conventional CCD camera at only 244 lines per shutter.

Double speed and partial scanning

By setting the speed switch on the back plate, the TM-6703 can scan with normal double speed (525 lines per 60 Hz), two-row scanning (242 lines at 120Hz), and partial scanning of 100 and 200 lines (full resolution at narrower field of view and faster frame rate).

Product Features

- High resolution 1/2" progressive scanning interline transfer CCD imager 648(H) x 484(V)
- Double speed progressive scan (525 lines/60Hz), Two-row scan (120Hz), or image center partial scan
- Full frame shutter, from 1/60 to 1/32,000 sec.
- Asynchronous reset with ext. shutter control
- Full frame integration
- On chip micro-lens and low smear at fast shutter
- AGC on/off, gamma 1 or 0.45
- Small, lightweight, ruggedized design
- Single channel VGA analog output

Switch selection

Normal mode:	N	O	60 Hz progressive scan, VGA
Double scan:	N	T	120 Hz two-row scan
100 line scan:	P	O	222 Hz progressive scan
200 line scan:	P	T	130 Hz progressive

Asynchronous Reset

The TM-6703's asynchronous reset is flexible and accepts external horizontal drive (HD) for phase locking. When VINIT pulse is applied, it resets the camera's scanning and purges the CCD. With async shutter mode and external VINIT high (5V), the async mode is automatically selected and the signal readout is inhibited until the trigger starts. Without VINIT, the camera remains in the normal mode.

Three modes control the asynchronous reset and shutter speed:

- 1. External VINIT with controlled pulse width.** The duration between pulse edges controls the shutter speed externally.
- 2. Internal shutter speed with Fast Mode.** The video signal capturing has no delay from the reset timing if the falling edges of VINIT and external HD are the same. Otherwise, there is a 0-1 HD delay (1H = 31.8µsec.)
- 3. Internal shutter speed with Slow Mode.** The speed control can be selected from 1/250 to 1/2,000 sec. The camera will discharge at VINIT falling edge, if VINIT and external HD falling edges are the same, and start accumulating charges. The output will be delayed depending on the selected shutter speed.

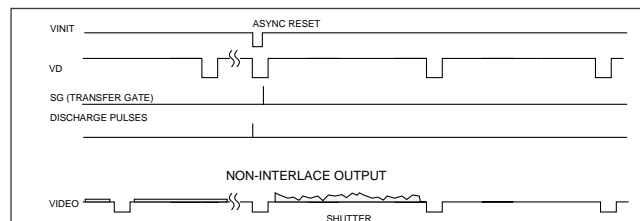

Product Specifications

Imager	1/2" progressive scanning interline transfer CCD
Pixel cell size	648 (H) x 484 (V)
Scanning	9.0 μm x 9.0 μm square pixels
	60 Hz (double speed) non-interlace, 120 Hz two-row scanning, partial scanning (100 and 200 lines)
Sync	Internal/external auto switch HD= 31.468KHz ±5% Vertical async. reset or VD=60Hz
Asynchronous reset	Ext. Vinit with output inhibit Ext. shutter speed control pulse (pulse width control)
Pixel clock	25.49 MHz
TV resolution	500 (H) x 484 (V) lines
S/N ratio	50dB min. (AGC = off)
Min. illumination	2 lux at normal speed
Video output	1.0 Vp-p composite video, 75Ω non-interlace
AGC	OFF (AGC ON is a factory option)
Gamma	1.0 (Gamma 0.45 is a factory option)
Electronic shutter	Asynchronous electronic shutter Mode A: 1/32,000 Max. (controlled by 1 H, 2 H, 4 H, ...) Mode B: External speed control pulse input Full frame resolution per shutter
Lens mount	C-mount
Power req.	12V DC 400 mA
Operating temp.	-10°C to 50°C *
Vibration & shock	Vibration: 7G RMS @ 10 ~ 2000Hz, Shock: 70G
Size (W x H x L)	46.1mm x 39.4mm x 140.0mm (1.78" x 1.52" x 5.41")
Weight	240 gr (9.0 oz)
Power cable	12P-02
Power supply	K25-12V or PD-12
Auto iris connector	None
Functional options	See current price list.

* NOTE: Image degradation may occur at increased temperatures.

Dimensions

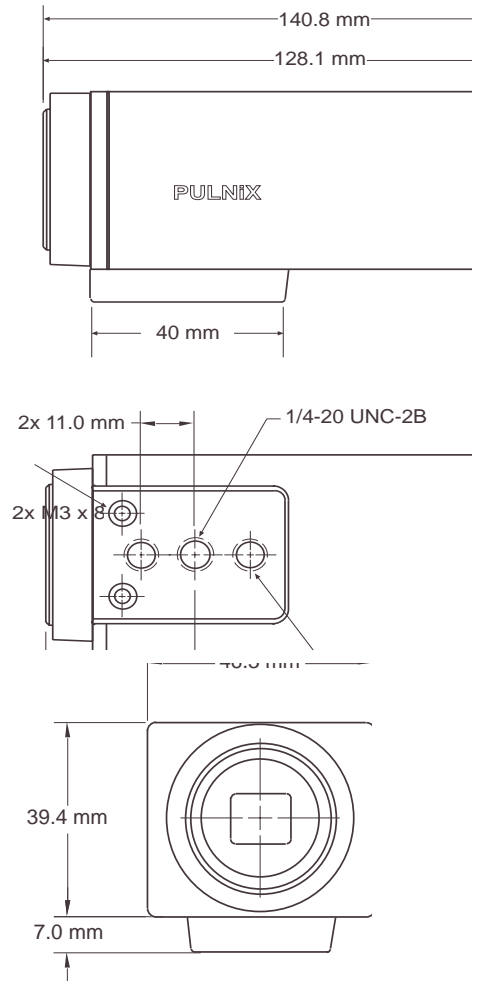

Integration

The CCD imager of the TM-6703 can be exposed longer than normal TV timing (1/60 sec.). This feature provides high sensitivity for dark environment applications. Integration is achieved by controlling the #11 pin of the 12-pin connector to Low (GND). The progressive scanning CCD chip in the TM-6703 produces a full frame of resolution; using a frame grabber to capture the image, one frame of integrated video is output as non-interlace format.

Pin Configurations

12-Pin Connector

1 GND	7 VD in
2 12V in	8 GND
3 GND	9 HD in
4 Video out	10 N/C
5 GND	11 Integ
6 Vinit	12 GND

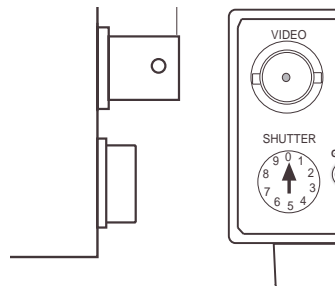
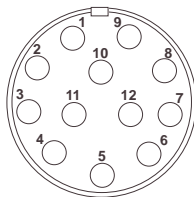

Rear Panel

Manual Shutter Control

	Manual Shutter	Async	Reset
0	no shutter	normal	1/60
1	1/125	1H	1/32,000
2	1/250	2H	1/16,000
3	1/500	4H	1/8,000
4	1/1,000	8H	1/4,000
5	1/2,000	16H	1/2,000
6	1/4,000	32H	1/1,000
7	1/8,000	64H	1/8,000
8	1/16,000	128H	1/250
9	1/32,000	Shutter determined by pulse width	

Async Reset Mode: Mode 0: normal mode;
Mode 1-4: fast mode; Mode 5-8: slow mode;
Mode 9: pulse width mode. At modes 1-9 the camera is at standby only, black video is output. One frame image will be output upon receiving an async reset pulse.

TM-6703

Japan, Tokyo
PULNiX America, Inc.
Ogura Building, 1-11-14 Hongo,
Bunkyo-ku, Tokyo, 113-033
Tel: 81-3-5805-2455
Fax: 81-3-5805-8082
Kyoto Office
Tel: 81-75-592-2247
Fax: 81-75-591-2333

Australia
PULNiX America Inc.
Unit 16, #35 Garden Road
Clayton, Vic 3168
Tel: 3-9546-0222
Fax: 3-9562-4892

United Kingdom
PULNiX Europe Ltd.
Aviary Court, Wade Road
Basingstoke, Hants RG24 8PE
Tel: 01256-475555
Fax: 01256-466268

Germany
PULNiX Europe Ltd.
Siemensstrasse 12
D-63755 Alzenau
Germany
Tel: 49(0)6023-9625-0
Fax: 49(0)6023-9625-11

ISO-9001
Cert. #A339 RVC



Industrial Products Division

PULNiX America Inc. Tel: 408-747-0300
1330 Orleans Drive Tel: 800-445-5444
Sunnyvale, CA 94089 Fax: 408-747-0660
Email: imaging@pulnix.com
www.pulnix.com

71-0025 Rev. A