

## MAIN FEATURES

- High sensitivity and high SNR performance linear CCD
- 1024, 2048 or 4096 resolution with 10µm square pixels
- 512, 1024 or 2048 resolution with 14µm square pixels
- 100 % aperture, Built-in anti blooming, No lag
- Camera Link™ data format (base configuration)
- High data rate up to 60 Mpixels/s
- Flexible and easy to operate via RS232 control
  - gain : 0dB to 40dB by step of 0.05dB
  - dynamic range : 8, 10 or 12bits data
  - offset (for contrast expansion)
  - trigger mode : free run or external trigger modes
  - data output mode (dual, single)
- Multi camera synchronization
- Single power supply : DC 12 V to 24 V
- Very Compact design : 56 x 60 x 38.6 mm (w,h,l)
- High reliability - CE & FCC compliant
- C, F (Nikon) or K (Pentax) mount adapter (lens not supplied)

## PRODUCT DESCRIPTION

This camera is designed with three concepts in mind : Compactness, accuracy and versatility.

- A very compact mechanical design incorporates a 0.5K to 4K sensors
- ATMEL manages the whole chain, from the sensor to the camera. The result is a camera able to work in 12 bits, with a dedicated electronics offering an excellent signal to noise ratio.
- The programmable settings let you work at different integration time, gain and offset. External clock and trigger allow to synchronise several cameras.

## APPLICATIONS

Performance and reliability of this camera make it well suited for the most demanding industrial applications, from web inspection to document scanning, from surface inspection to metrology.



**AVIIVA™**

**CameraLink™  
linescan  
camera**



Issue 2.4 – 07 FEB 2002



## 1. TYPICAL PERFORMANCES

| Sensor characteristics at maximum pixel rate   |                           |                                       |      |   |      |      |
|--|---------------------------|---------------------------------------|------|---|------|------|
| Resolution                                     | pixels                    | 512                                   | 1024 | 2048                                      | 4096 |      |
| Pixel size (square)                            | µm                        | 14                                    | 14   | 14  | -    |      |
|  | µm                        | -                                     | 10   | 10  | 10   |      |
| Max Line rate                                  | kHz                       | 109                                   | 57   | 29  | 15   |      |
| Anti blooming                                  |                           | x 150                                 |      |   |      |      |
| Radiometric performances at maximum pixel rate |                           |                                       |      |   |      |      |
| Dynamic range                                  | bits                      | 12 (also configurable in 8 or 10)     |      |   |      |      |
| Spectral range                                 | nm                        | 250 - 1100                            |      |   |      |      |
| Linearity                                      | %                         | << 1%                                 |      |   |      |      |
| Gain range (step of 0.047dB)                   |                           | Gmin                                  | Gnom | Gmax                                      |      |      |
|  | dB                        | 0                                     | 18   | 30  |      |      |
| Peak response (typical)                        | 14µm pitch                | LSB/nJ/cm <sup>2</sup>                | 130  |   | 1040 | 4180 |
|  | 10µm pitch                |                                       | 50   |   | 400  | 1600 |
| Output RMS noise (typical)                     | SNR                       | dB                                    | 67.4 | 49  | 37   |      |
|  | Effective bits            | bits                                  | 11.2 | 8.2                                       | 6.2  |      |
|  | Input RMS Noise (typical) |                                       |      |   |      |      |
| 14µm pitch                                     | pJ/cm <sup>2</sup>        |                                       |      | 14  |      |      |
| 10µm pitch                                     | pJ/cm <sup>2</sup>        |                                       |      | 37  |      |      |
| Mechanical & electrical interface              |                           |                                       |      |   |      |      |
| Size (w x h x l)                               | mm                        | 56 x 60 x 38.6                        |      |   |      |      |
| Lens mount                                     |                           | C, F, K                               |      |   |      |      |
| Sensor alignment (refer to §8.4)               | µm                        | $\Delta x, y = \pm 50 \mu\text{m}$    |      | $\Delta z = 0-30 \mu\text{m}$             |      |      |
|  |                           | $\Delta \theta_{x,y} = \pm 0.2^\circ$ |      | $\Delta \text{tilt}_z = 0-35 \mu\text{m}$ |      |      |
| Power supply                                   | V                         | DC, single 12 to 24 V                 |      |   |      |      |
| Power dissipation                              | W                         | < 8                                   |      |   |      |      |
| Operating temperature                          | °C                        | 0 to 55 (non condensing)              |      |   |      |      |
| Storage temperature                            | °C                        | 0 to 75 (non condensing)              |      |   |      |      |
| Spectral response                              |                           |                                       |      |   |      |      |
|  |                           |                                       |      |   |      |      |

## 2. CAMERA DESCRIPTION

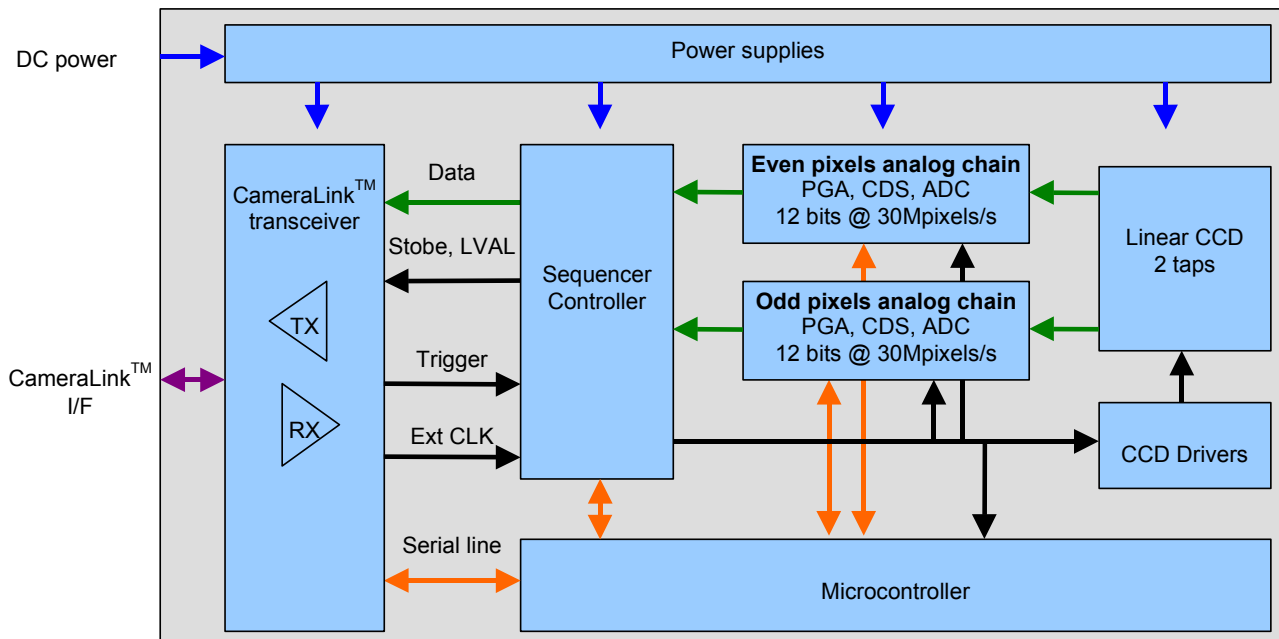

Figure 2 – Camera synoptic

The camera is based on a two taps linear CCD. Therefore, two analog chains process odd and even pixels of the linear sensor. The analog chains performed the CCD output processing. It encompasses the correlated double sampling (CDS), the dark level correction (dark pixel clamping), the gain (PGA) and offset correction and finally the analog to digital conversion on 12 bits.

Note : PGA stands for programmable gain array

The camera is supplied by a single DC power voltage from 12 to 24 V.

The functional interface (data and control) is provided by the CameraLink™ interface.

The camera uses the base configuration of CameraLink™ standard.

Note : DVAL=1 and FVAL=0

The data can be provided on two channels or in a single multiplexed channel. The data format can be configured in 8, 10 or 12 bits.

The camera can be used with external triggers (TRIG1 and TRIG2 signals) in different trigger modes (refer to §5.1). The camera can be also clocked externally, allowing system synchronisation and/or multi-camera synchronisation.

The camera configuration and settings is performed via a serial line. This interface is used for :

- Gain, offset setting
- Dynamic range, data rate setting
- Trigger mode setting : free run or external trigger modes
- Integration time setting : in free running & external trigger mode



### 3. STANDARD CONFORMITY

The cameras have been tested in the following conditions :

- Shielded power supply cable
- CameraLink data transfer cable ref. 14B26-SZLB-500-OLC (3M)
- Linear AC-DC power supply

We recommend to use the same configuration to ensure the compliance with the following standards.

#### 3.1 CE CONFORMITY

AVIIVA Cameras complies with the European directive 89/336/CEE (EN 50081-2, EN 61000-6-2)

#### 3.2 FCC CONFORMITY

AVIIVA Cameras complies with Part 15 of FCC rules. Operation is subject to the following two conditions :

- This device may not cause harmful interference, and
- This device must accept any interference received, including interference that may cause undesired operation.

This equipment has been tested and found to comply with the limits for a Class A digital device, pursuant to part 15 of the FCC Rules. These limits are designed to provide reasonable protection against harmful interference when the equipment is operated in a commercial environment. This equipment generates, uses, and can radiate radio frequency energy and, if not installed and used in accordance with the instruction manual, may cause harmful interference to radio communications. Operation of this equipment in a residential area is likely to cause harmful interference in which case the user will be required to correct the interference at his own expense.

Warning : Changes or modifications to this unit not expressly approved by the party responsible for compliance could void the user's authority to operate this equipment.



## 4. CAMERA COMMAND AND CONTROL

Camera configuration is set by the serial interface. Please refer to §6.4 for the detailed protocol of the serial line.

| Setting              | Command             | Parameter         | Description   |
|----------------------|---------------------|-------------------|---|
| Configuration record | E=                  | 0                 | The camera configuration is recorded on each change                 |
|                      |                     | 1                 | The camera configuration is recorded only on request                |
| Gain (1)             | G=                  | 0 to 851          | Gain setting from 0 to 40 dB (~0.047dB steps)                       |
| Data transfer (2)    | H=                  | 0                 | Two outputs on external clock                                       |
|                      |                     | 1                 | One output (multiplexed) on external clock                          |
|                      |                     | 3                 | One output (multiplexed) at 20MHz data rate                         |
|                      |                     | 5                 | One output (multiplexed) at 30MHz data rate                         |
|                      |                     | 6                 | Two outputs at 20MHz data rate                                      |
|                      |                     | 7                 | One output (multiplexed) at 40MHz data rate                         |
|                      |                     | 8                 | Two outputs at 30MHz data rate                                      |
|                      |                     | 9                 | One output (multiplexed) at 60MHz data rate                         |
|                      |                     | Output format (3) | S=  |
| 1                    | 10 bits Output data |                   |   |
| 2                    | 8 bits Output data  |                   |   |
| Pattern (4)          | T=                  | 0                 | Standard  |
|                      |                     | 1                 | Pattern   |
| Integration Time     | I=                  | 5 to 13000        | Integration time (µs) in free run or external triggered mode        |
| Trigger mode         | M=                  | 1                 | Free run with integration time setting (see timing diagram)         |
|                      |                     | 2                 | External trigger with integration time setting (see timing diagram) |
|                      |                     | 3                 | Trigger and Integration time controlled                             |
|                      |                     | 4                 | Trigger and integration time controlled by two inputs               |
| Even data Offset (5) | O=                  | 0 to 15           | Even Offset setting from 0 to approx. 200 LSB                       |
| Odd data Offset (5)  | P=                  | 0 to 15           | Odd Offset setting from 0 to approx. 200 LSB                        |
| Special commands     | !=                  | 0                 | Camera identification readout                                       |
|                      |                     | 1                 | User camera identification readout                                  |
|                      |                     | 2                 | Software version readout  |
|                      |                     | 3                 | Camera configuration readout  |
|                      |                     | 4                 | Current camera configuration record                                 |
|                      |                     | 5                 | Default camera configuration restoration                            |
| User camera ID       | \$=                 | String of Char.   | Writing and record of the user camera identification                |

- (1) Camera gain (dB) =  $G \times 0.047$
- (2) Commands "H=2" and "H=4" will give 10 and 15MHz data rate which are not compatible with Camera Link standard. Please don't use it.
- (3) The pinout corresponding to this options is fully compatible with the Camera Link standard (see par. 7)
- (4) The pattern is useful to check if the interfacing is well done. You should see a jagged image of 255 pixels steps.
- (5) The offset is set in manufacturing to balance both the channels. The initial setting is about 8 (~ 130 LSB). In some cases, you may have to change it (for example if the ambient temperature is very high).

## 5. TIMING

### 5.1 SYNCHRONISATION MODE

Four different modes may be used under user control.

The TRIG1 and TRIG2 signals may be used to trigger an external event and to control the integration time.

The Master clock is either external or internal clock.

#### 5.1.1 FREE RUN MODE WITH INTEGRATION TIME SETTING

The integration and readout periods start automatically and immediately after the previous period.

\*The Integration time is set by the serial line and should be higher than the read-out time (otherwise it is adjusted to the readout time).

The read-out time depends on pixel number and pixel rate.

| Label | Description   | Min | Typ       | Max   |
|-------|---|-----|-----------|-------|
| ti    | Integration time duration                                 | *   |           | 13 ms |
| tg    | Consecutive integration period gap (at maximum frequency) |     | 6 $\mu$ s |       |
| tt    | Integration period to read-out delay                      |     | 1 $\mu$ s |       |

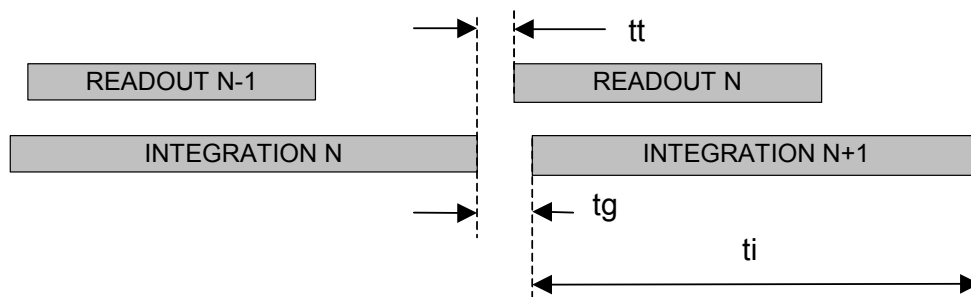

#### 5.1.2 TRIGGERED MODE WITH INTEGRATION TIME SETTING

The integration period starts immediately after the rising edge of TRIG1 input signal. The Integration time is set by the serial line.

This integration period is immediately followed by a readout period. The read-out time depends on pixel number and the pixel rate.

| Label | Description                                    | Min       | Typ         | Max   |
|-------|--|-----------|-------------|-------|
| ti    | Integration time duration                      | 5 $\mu$ s |             | 13 ms |
| td    | TRIG1 rising to integration period delay       |           | 5.5 $\mu$ s |       |
| tt    | Integration period to read-out delay           |           | 1 $\mu$ s   |       |
| ts    | Integration period to TRIG1 rising set-up time | 4 $\mu$ s |             |       |
| th    | TRIG1 hold time (pulse high duration)          | 1 $\mu$ s |             |       |

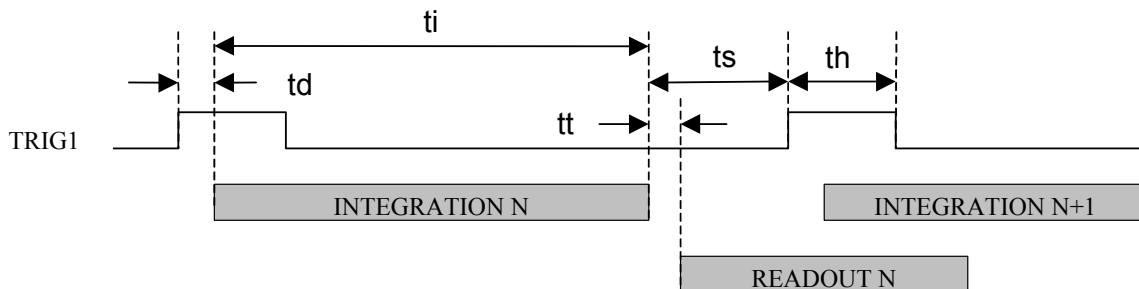

### 5.1.3 TRIGGERED AND INTEGRATION TIME CONTROLLED

The integration period starts immediately after the falling edge of TRIG1 input signal.

The integration period stops immediately after the rising edge of TRIG1 input signal.

This integration period is immediately followed by a readout period.

The read-out time depends on pixel number and pixel rate.

| Label | Description                              | Min       | Typ         | Max |
|-------|--|-----------|-------------|-----|
| ti    | Integration time duration                | 5 $\mu$ s |             |     |
| td1   | TRIG1 rising to integration period delay |           | 100 ns      |     |
| td2   | TRIG2 rising to integration period delay |           | 1.3 $\mu$ s |     |
| tt    | Integration period to read-out delay     |           | 1 $\mu$ s   |     |
| th    | TRIG1 hold time (pulse high duration)    | 1 $\mu$ s |             |     |

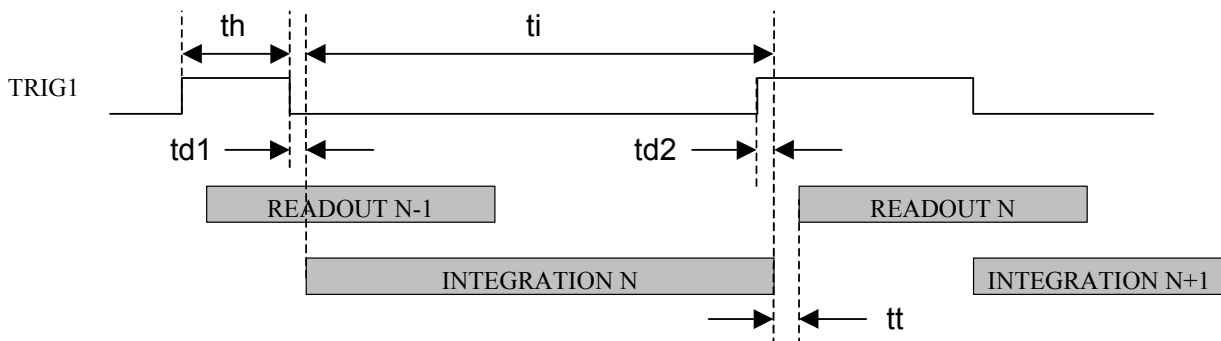

### 5.1.4 TRIGGER AND INTEGRATION TIME CONTROLLED BY TWO INPUTS

TRIG2 rising edge start the integration period.

TRIG1 rising edge stop the integration period.

This period is immediately followed by a readout period.

| Label | Description                                   | Min       | Typ         | Max |
|-------|---|-----------|-------------|-----|
| ti    | Integration time duration                     | 5 $\mu$ s |             |     |
| td1   | TRIG2 rising to integration period delay      |           | 100 ns      |     |
| td2   | TRIG1 rising to integration period delay      |           | 1.3 $\mu$ s |     |
| tt    | Integration period to read-out delay          |           | 1 $\mu$ s   |     |
| th    | TRIG1 & TRIG2 hold time (pulse high duration) | 1 $\mu$ s |             |     |

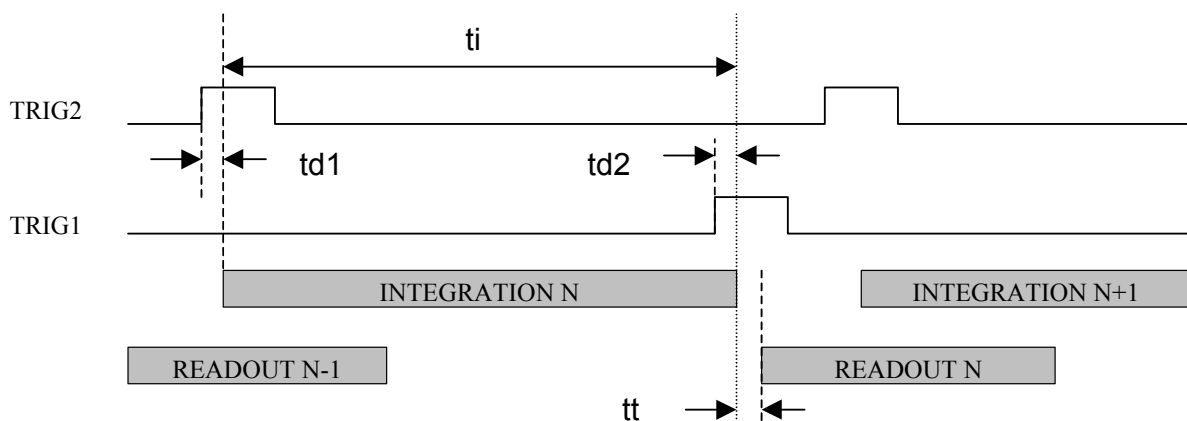

## 5.2 OUTPUT DATA TIMING

This timing correspond to the input data of the “Chanel Link” interface. The camera output data are not detailed here because fully compliant with the Camera Link standard (serial high speed interface)

| Label | Description  | Min   | Typ  | Max   |
|-------|--|-------|------|-------|
| tp    | Input falling edge to output clock propagation delay |       | 7 ns |       |
| td    | STROBE to synchronised signals delay                 | -5 ns |      | +5 ns |

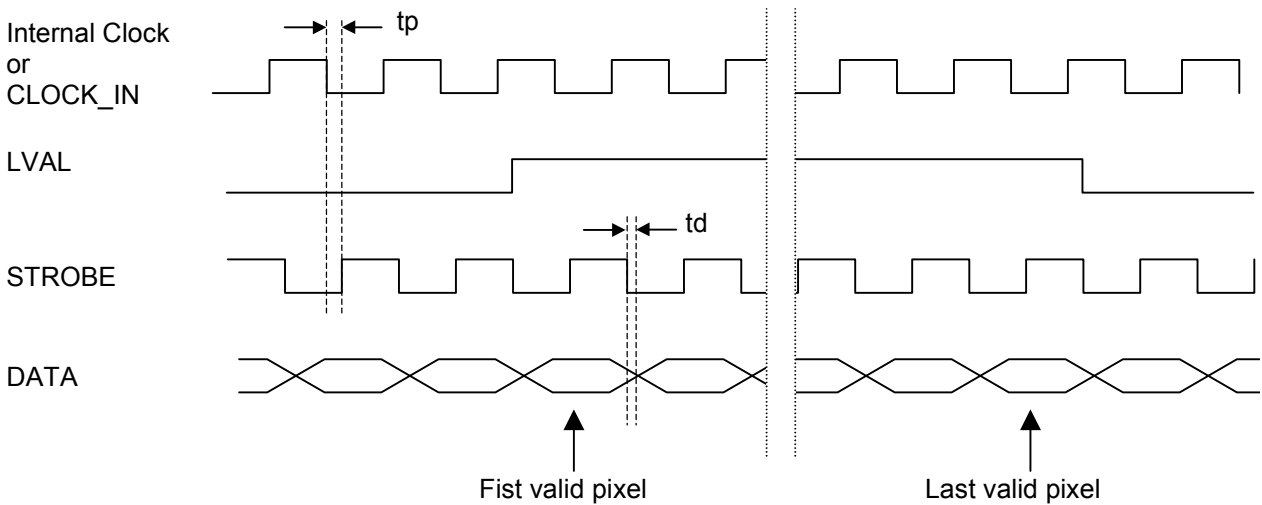

Note : CLOCK\_IN Input must stay between 5 to 60MHz. Out of this range, the performances may be decreased.





## 6. ELECTRICAL INTERFACE

### 6.1 POWER SUPPLY

It is recommended to insert a 1A fuse between the power supply and the camera.

| Signal name | I/O | Type | Description                            |
|-------------|-----|------|--|
| PWR         | P   | -    | DC power input : +12V to +24V (+-0.5V) |
| GND         | P   | -    | Electrical and Mechanical ground       |

I = input, O = output, IO = bi-directional signal, P = power/ground, NC = not connected

### 6.2 CAMERA CONTROL

The CameraLink™ interface provides four LVDS signals dedicated to camera control (CC1 to CC4).

On the AVIIVA, three of them are used to synchronise the camera on external events.

| Signal name | I/O | Type  | Description   |
|-------------|-----|-------|---|
| TRIG1       | I   | RS644 | CC1 - Synchronisation input (refer to §5.1)                             |
| TRIG2       | I   | RS644 | CC2 - Start Integration period in dual synchro mode (refer to §5.1)     |
| CLOCK_IN    | I   | RS644 | CC4 - External clock for (multi-)camera synchronisation (refer to §5.1) |

I = input, O = output, IO = bi-directional signal, P = power/ground, NC = not connected

Note : CC3 is not used.

### 6.3 VIDEO DATA

Data and enable signals are provided on the CameraLink™ interface

| Signal name | I/O | Type  | Description   |
|-------------|-----|-------|---|
| ODD[11-0]   | O   | RS644 | Odd pixel data (refer to §5.2), ODD-00 = LSB, ODD-11 = MSB        |
| EVEN[11-0]  | O   | RS644 | Even pixel data (refer to §5.2), EVEN-00 = LSB, EVEN-11 = MSB     |
| STROBE      | O   | RS644 | Output data clock. (refer to §5.2), data valid on the rising edge |
| LVAL        | O   | RS644 | Line valid (refer to §5.2), active high signal                    |

I = input, O = output, IO = bi-directional signal, P = power/ground, NC = not connected

Notes : FVAL, as defined in the CameraLink™ standard, is not used. FVAL is permanently tied to 0 (low) level.

DVAL is not used. DVAL is permanently tied to 1 (high) level.

In case of Single output, the data (multiplexed) are output in place of Odd data.



## 6.4 SERIAL COMMUNICATION

The CameraLink™ interface provides two LVDS signal pairs for the communication between the camera and the frame grabber. This is an asynchronous serial communication based on RS-232 protocol.

The configuration of the serial line is :

- Full duplex / without handshaking
- 9600 bauds, 8 bits data, no parity bit, 1 stop bit.

| Signal name | I/O | Type  | Description   |
|-------------|-----|-------|---|
| SerTFG      | O   | RS644 | Differential pair for serial communication to the frame grabber   |
| SerTC       | I   | RS644 | Differential pair for serial communication from the frame grabber |

### Command syntax

The valid syntax is : "S=n(CR)" with :

S : command identification as per §4. S is a single character in upper case.

n : setting value.

(CR) : means "carriage return".

no spaces, nor tabs may be inserted between S, =, n and (CR).

example of a valid command :

G=3(CR) : sets the camera to gain 3 (refer to §4 for exact value calculation)

example of non valid commands :

G = 3(CR) : spaces

g=3(CR) : g instead of G

G=1040(CR) : 1040 is outside of range.

### Command processing

Each command received by the camera is processed :

if the command is valid :

- the setting is done in case of a write command
- the camera returns the data separated by (CR) in case of the read command
- the camera returns : >OK(CR)

if the command is not valid :

- nothing is done.
- the camera returns : >1 = out of range ; >2 = syntax error ; >3 = command too long ; >4,>6,>7 = internal error ; >5 undefined function

**example :** when receiving "!=3(CR)" the camera returns its current settings :

A=0(CR)

B=0(CR)

....

E=0(CR)

>OK(CR)

## 7. CONNECTOR DESCRIPTION

All connectors are on the rear panel.

Note : cables for digital signals shall be shielded twisted pairs.

### 7.1 POWER SUPPLY

Camera connector type : Hirose HR10A-7R-6PB (male)

Cable connector type : Hirose HR10A-7P-6S (female)

| Signal | Pin | Signal | Pin |
|--------|-----|--------|-----|
| PWR    | 1   | GND    | 4   |
| PWR    | 2   | GND    | 5   |
| PWR    | 3   | GND    | 6   |

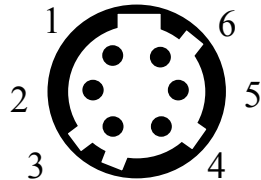
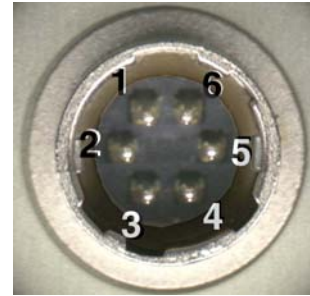

Receptacle viewed from camera back

### 7.2 CAMERALINK™ CONNECTOR

Standard CameraLink™ cable shall be used to ensure the full electrical compatibility.

Camera connector type : MDR-26 (female) ref. 10226-2210VE

Cable connector type : Standard CameraLink™ cable shall be used (ex. 3M - 14B26-SZLB-x00-OLC)

| Signal  | Pin | Signal  | Pin |
|---------|-----|---------|-----|
| GND     | 1   | GND     | 14  |
| X0-     | 2   | X0+     | 15  |
| X1-     | 3   | X1+     | 16  |
| X2-     | 4   | X2+     | 17  |
| Xclk-   | 5   | Xclk+   | 18  |
| X3-     | 6   | X3+     | 19  |
| SerTC+  | 7   | SerTC-  | 20  |
| SerTFG- | 8   | SerTFG+ | 21  |
| CC1-    | 9   | CC1+    | 22  |
| CC2+    | 10  | CC2-    | 23  |
| CC3-    | 11  | CC3+    | 24  |
| CC4+    | 12  | CC4-    | 25  |
| GND     | 13  | GND     | 26  |



## Bit Assignments

This bit assignment is compliant with the CameraLink™ Specification in the **Base Configuration**.

In "single output" mode (multiplexed), the data are output on ODD-xx bits.

### When used in 12 bits data (S=0)

| Bit    | DS90CR285 pin name | Bit     | DS90CR285 pin name | Bit     | DS90CR285 pin name | Bit     | DS90CR285 pin name |
|--------|--------------------|---------|--------------------|---------|--------------------|---------|--------------------|
| ODD-00 | Tx0                | ODD-07  | Tx5                | EVEN-02 | Tx19               | EVEN-09 | Tx14               |
| ODD-01 | Tx1                | ODD-08  | Tx7                | EVEN-03 | Tx20               | EVEN-10 | Tx10               |
| ODD-02 | Tx2                | ODD-09  | Tx8                | EVEN-04 | Tx21               | EVEN-11 | Tx11               |
| ODD-03 | Tx3                | ODD-10  | Tx9                | EVEN-05 | Tx22               | STROBE  | TxCLK              |
| ODD-04 | Tx4                | ODD-11  | Tx12               | EVEN-06 | Tx16               | LVAL    | Tx24               |
| ODD-05 | Tx6                | EVEN-00 | Tx15               | EVEN-07 | Tx17               |         |                    |
| ODD-06 | Tx27               | EVEN-01 | Tx18               | EVEN-08 | Tx13               |         |                    |

### When used in 10 bits data (S=1)

| Bit    | DS90CR285 pin name | Bit     | DS90CR285 pin name | Bit     | DS90CR285 pin name | Bit     | DS90CR285 pin name |
|--------|--------------------|---------|--------------------|---------|--------------------|---------|--------------------|
| ODD-00 | Tx0                | ODD-07  | Tx5                | EVEN-02 | Tx19               | EVEN-09 | Tx14               |
| ODD-01 | Tx1                | ODD-08  | Tx7                | EVEN-03 | Tx20               | NC      | Tx10               |
| ODD-02 | Tx2                | ODD-09  | Tx8                | EVEN-04 | Tx21               | NC      | Tx11               |
| ODD-03 | Tx3                | NC      | Tx9                | EVEN-05 | Tx22               | STROBE  | TxCLK              |
| ODD-04 | Tx4                | NC      | Tx12               | EVEN-06 | Tx16               | LVAL    | Tx24               |
| ODD-05 | Tx6                | EVEN-00 | Tx15               | EVEN-07 | Tx17               |         |                    |
| ODD-06 | Tx27               | EVEN-01 | Tx18               | EVEN-08 | Tx13               |         |                    |

### When used in 8 bits data (S=2)

| Bit    | DS90CR285 pin name | Bit     | DS90CR285 pin name | Bit     | DS90CR285 pin name | Bit     | DS90CR285 pin name |
|--------|--------------------|---------|--------------------|---------|--------------------|---------|--------------------|
| ODD-00 | Tx0                | ODD-07  | Tx5                | NC      | Tx19               | EVEN-05 | Tx14               |
| ODD-01 | Tx1                | EVEN-00 | Tx7                | NC      | Tx20               | EVEN-06 | Tx10               |
| ODD-02 | Tx2                | EVEN-01 | Tx8                | NC      | Tx21               | EVEN-07 | Tx11               |
| ODD-03 | Tx3                | EVEN-02 | Tx9                | NC      | Tx22               | STROBE  | TxCLK              |
| ODD-04 | Tx4                | EVEN-03 | Tx12               | NC      | Tx16               | LVAL    | Tx24               |
| ODD-05 | Tx6                | NC      | Tx15               | NC      | Tx17               |         |                    |
| ODD-06 | Tx27               | NC      | Tx18               | EVEN-04 | Tx13               |         |                    |

## 8. MECHANICAL CHARACTERISTICS

### 8.1 WEIGHT

The camera typical weight (without lens nor lens adapter) is 220 g (typical)

### 8.2 DIMENSIONS

The camera dimension (without lens) are W = 56 mm, H = 60 mm, L = 38.6 mm

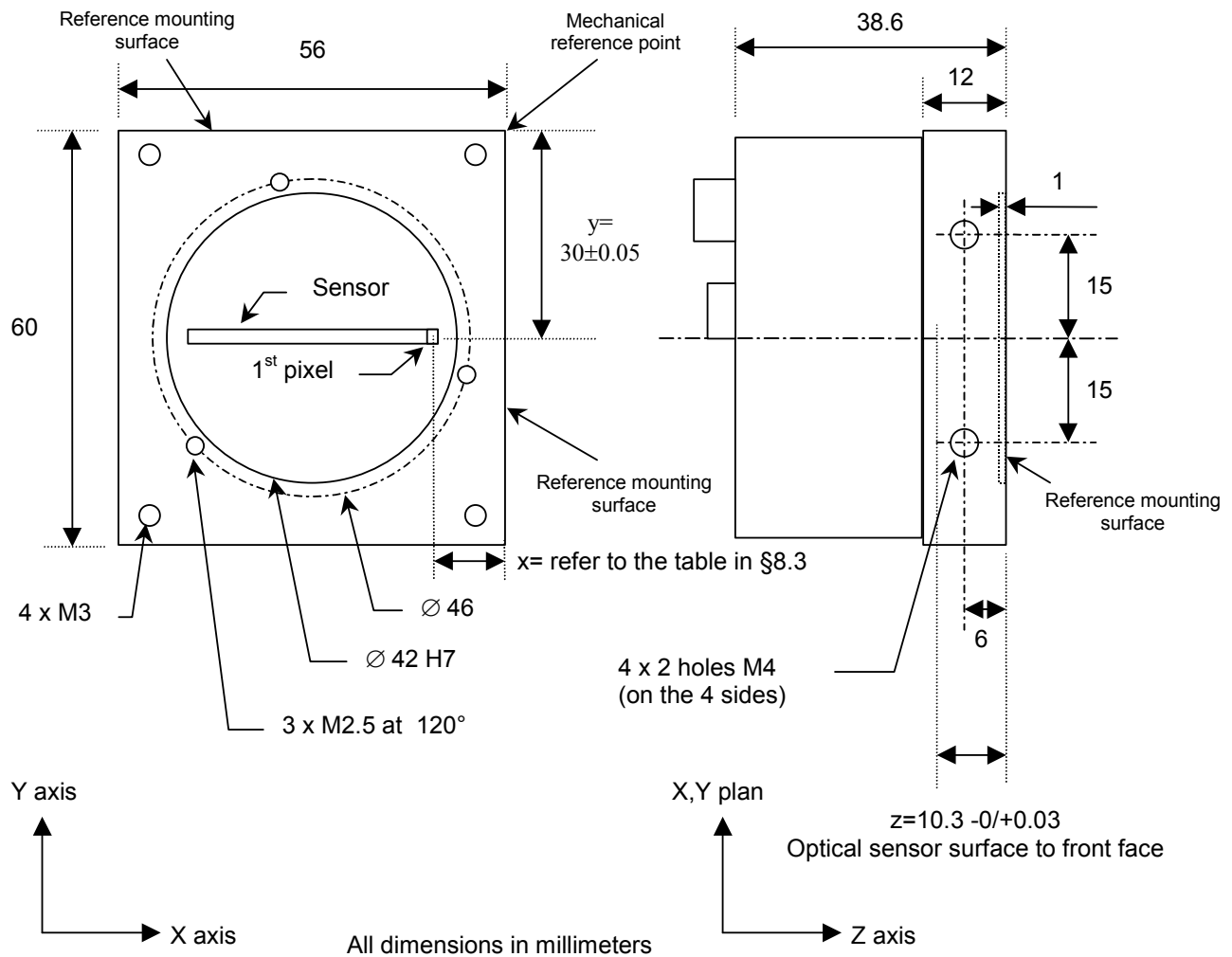

Figure 3 – Mechanical Box drawing and dimensions

### 8.3 MECHANICAL MOUNTING REFERENCE

The front panel mechanical part is design to support the mounting of the camera. On this mechanical part, three surfaces are considered as mounting reference surface : i.e. the distance between these surfaces and the first active pixel are known very precisely (better than  $\pm 50\mu\text{m}$ ).

| Number of pixel                   | 512    | 1024   | 2048   | 4096  |
|-----------------------------------|--------|--------|--------|-------|
| x in 14 $\mu\text{m}$ sensor (nm) | 24.416 | 20.832 | 13.664 | -     |
| x in 10 $\mu\text{m}$ sensor (nm) | -      | 22.880 | 17.760 | 7.520 |

## 8.4 SENSOR ALIGNEMENT

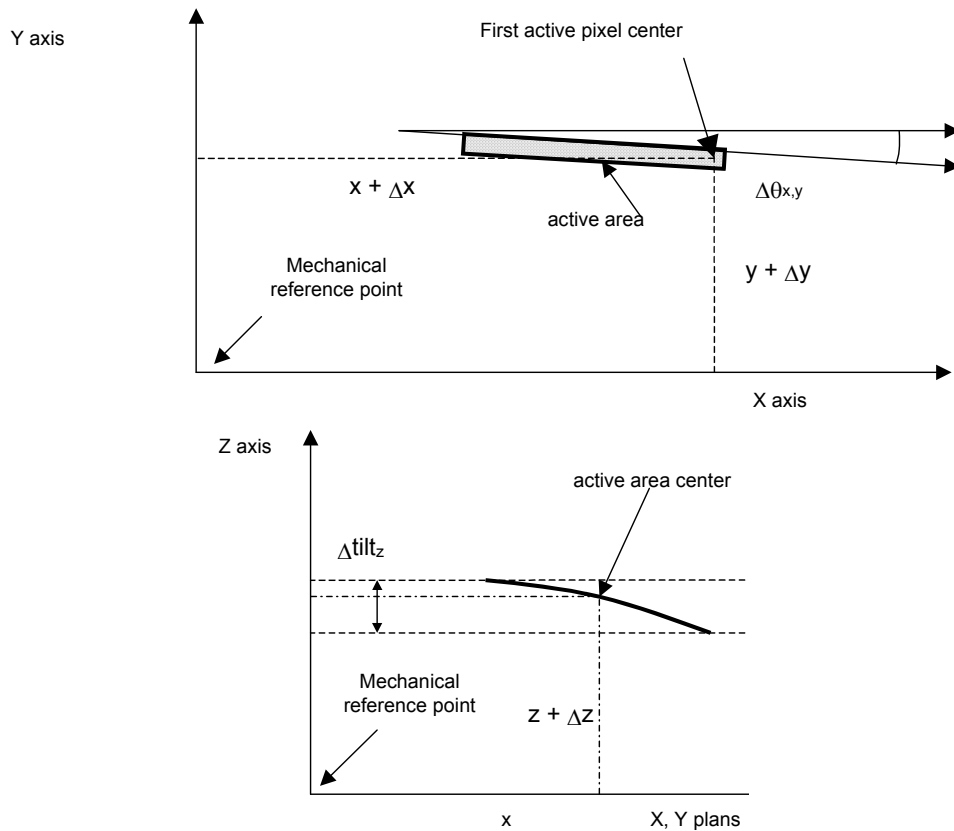

Figure 4 - Sensor alignment diagram

## 8.5 LENS MOUNTING (LENS NOT SUPPLIED)

The camera can be provided with three different lens adapter, corresponding to three different options. It is up to the customer to selected the correct adapter. The following table gives recommendation depending on the sensor size

| Number of pixel | 512 / 14μm | 1024 / 10μm | 1024 / 14μm | 2048 / 10μm | 2048 / 14μm | 4096 / 10μm |
|-----------------|------------|-------------|-------------|-------------|-------------|-------------|
| <b>C mount</b>  | OK         | OK          | ≈OK         | not usable  | not usable  | not usable  |
| <b>F mount</b>  | OK         | OK          | OK          | OK          | OK          | OK          |
| <b>K mount</b>  | OK         | OK          | OK          | OK          | OK          | OK          |

## 8.6 HEAT-SINK MOUNTING

In order to improve the power dissipation, the camera can be delivered with heat-sink to be mounted by the user on the side faces of the camera. The delivery of the heat-sinks corresponds to a dedicated option.



## ORDERING CODE

| Part Number        | Resolution | Pixels size | Description  |
|--------------------|------------|-------------|--|
| AT71LKLB1K0F-BAA   | 1 K        | 10 µm       | AVIIVA camera (without any mount)                        |
| AT71LKLB2K0F-BAA   | 2 K        | 10 µm       | AVIIVA camera (without any mount)                        |
| AT71LKLB4K0F-BAA   | 4 K        | 10 µm       | AVIIVA camera (without any mount)                        |
| AT71LKLB0K5K-BAA   | 512        | 14 µm       | AVIIVA camera (without any mount)                        |
| AT71LKLB1K0K-BAA   | 1 K        | 14 µm       | AVIIVA camera (without any mount)                        |
| AT71LKLB2K0K-BAA   | 2 K        | 14 µm       | AVIIVA camera (without any mount)                        |
|                    |            |             |  |
| AT71KFPVIVA-ABA    |            |             | F mount (NIKON)  |
| AT71KFPVIVA-ACA    |            |             | C mount  |
| AT71KFPVIVA-AKA    |            |             | K mount (PENTAX)   |
|                    |            |             |  |
| AT71KAVIVAP2C0D3A0 |            |             | Cables kit :<br>10m power supply & 5m Camera Link cables |
|                    |            |             |  |

Information furnished is believed to be accurate and reliable. However Atmel- assumes no responsibility for the consequences of use of such information nor for any infringement of patents or other rights of third parties which may result from its use. No license is granted by implication or otherwise under any patent rights of Atmel-. Specifications mentioned in this publication are subject to change without notice. This publication supersedes and replaces all information previously supplied. Atmel- products are not authorised for use as critical components in life support devices or systems without express written approval from Atmel-.

© 2002 Atmel-GFO- Printed in France - All rights reserved.

This product is manufactured by Atmel-GFO- 38521 SAINT-EGREVE - FRANCE.

For further information please contact :

**ATMEL**

2, allée Maryse Bastié

Z.I. d'Orlytech

91781 WISSOUS Cedex – FRANCE

Phone +33 (0)1 49 75 96 00 - Fax +33 (0) 1 49 75 96 01 - Internet : <http://www.atmel.com>