

SPEED CONTROL AND MONITORING ENSURE FANS THAT ARE QUIETER, MORE RELIABLE, AND MORE ENERGY-EFFICIENT IN THEIR VITAL THERMAL-MANAGEMENT ROLE.

Cooling down with fan-speed control

IN MANY NEW DESIGNS, smaller packaging, ever-shrinking boxes, and high-power ICs can cause heat problems. Fans can minimize overheating, but unfortunately, they are prone to mechanical problems, increased power consumption, and amplified noise. Fan-speed control allows for greater efficiency and fewer long-range problems.

Designers tend to choose brushless dc fans for most electronic enclosure designs. These fans couple high reliability with ease of use. The basic dc brushless fan is a two-wire device to which you apply a dc voltage. The simplest approach to system cooling is to connect a fan to a dc power supply and let it run. A quick glance at fan catalogs reveals that some fans operate at a nominal 5, 12, 24, or 48V. At present, 12V fans are the most popular in nontelecom applications.

These dc fans are “brushless” because commutation occurs electronically within the fan itself. Older dc fans used mechanical brushes, which spewed particles and EMI throughout the system. Over time, these brushes would wear and eventually fail. Brushless fans have replaced mechanical brushes with electronic sensors and switches. Consequently, new fans are more reliable and have longer lives than older fans. Commutation circuitry is mounted within the fan and is transparent to the user. The end result is an easy-to-use, reliable, two-wire device.

To the end user, brushless dc fans are simple to electrically characterize. As the dc voltage applied to the fan varies, its speed and current draw also vary. To a first order, speed and current are directly pro-

portional to the dc voltage applied (Figures 1 and 2).

Brushless commutation significantly increases the lifetime and reliability of fans. However, fans mechanical and prone to wear and failure. Over time, fan speed and cooling efficiency can slowly degrade or completely fail, so your fan may need occasional checkups. Most fan manufacturers offer a variety of ways to monitor fans, including alarm and speed sensors. Alarm sensors typically give a digital signal, which indicates the fan has fallen below a threshold of speed or has stopped working. For example, EBM/Papst offers an option that generates a series of digital pulses whenever the speed of the fan drops to 75 to 85% of its nominal speed.

EBM/Papst, NMB, and other manufacturers offer fans with speed sensors that give a digital output whose frequency is proportional to fan speed. The most common speed sensor gives two pulses per revolution. Depending on the manufacturer and the

Figure 1

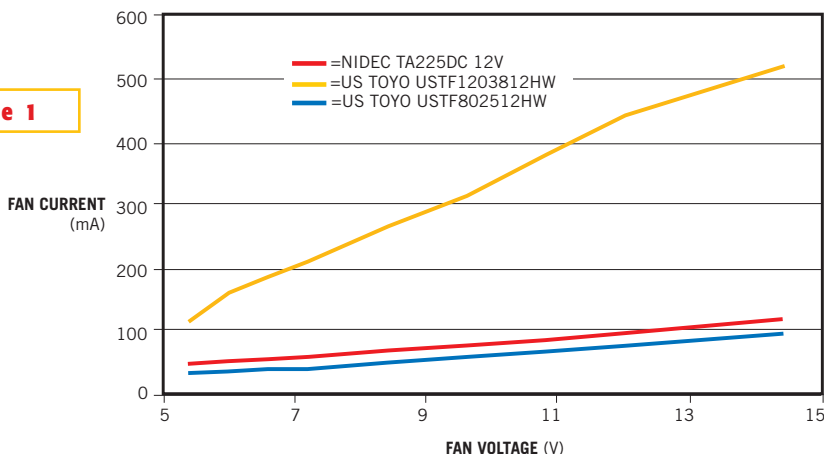

The fan draws a current that is proportional to applied fan voltage but varies from fan model to model.

options it offers, you can order both speed and alarm sensors with either open-collector or internally pulled-up outputs; the alarm sensor's pulled-up outputs can be TTL-compatible or swing through the full supply voltage of the fan. Note that the alarm and speed sensors share the same supply voltage as the motor and commutation electronics. Any changes in supply voltage to control the fan speed also affect the commutation electronics and the speed/ alarm sensors.

WHY USE SPEED CONTROL?

When you select a fan for an application, the design must be able to withstand worst-case conditions. For example, you need to select a fan that can move enough air to keep the system cool even with worst-case ambient temperature, power dissipation, fan production tolerances, and fan aging. In reality, the system will infrequently face these conditions. In most situations, you can reduce fan speed without adversely affecting the system and increase the speed only when conditions demand it. But why should you go to the trouble?

One of the most noticeable advantages of fan-speed control is reduced noise. Fans running at full speed can be a significant source of annoyance, especially for equipment used in quiet office environments. In most offices, the temperature is significantly lower than the maximum temperature electronic equipment can handle, so you can decrease fan speed without adverse effects, much to the relief of everyone within hearing distance. With lower fan speeds, applications such as laptops benefit from reduced power consumption. You can roughly approximate power consumption as the square of the fan's normalized speed (**Figure 3**).

Reducing fan speed also reduces wear. Fan wear is a rough function of the absolute number of revolutions of the fan. Because fans are mechanical, they tend to have some of the lowest MTBFs in a system. Any improvements you make to a fan's MTBF can result in a significant increase in the MTBF of the end equipment.

In addition, you can extend the system's life by minimizing the rate at which systems collect dust. As anyone who has opened up old equipment

Figure 2

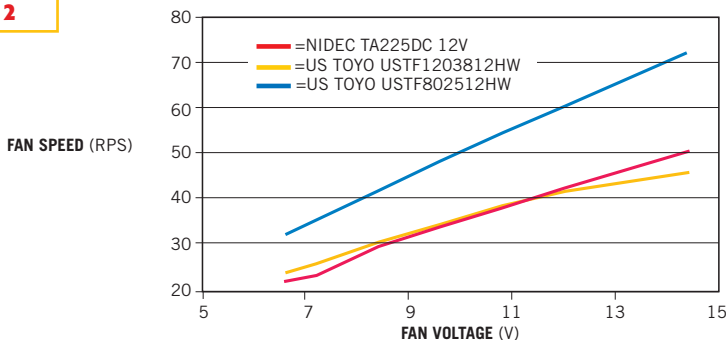

Fan speed, like current, is also proportional to applied fan voltage.

Figure 3

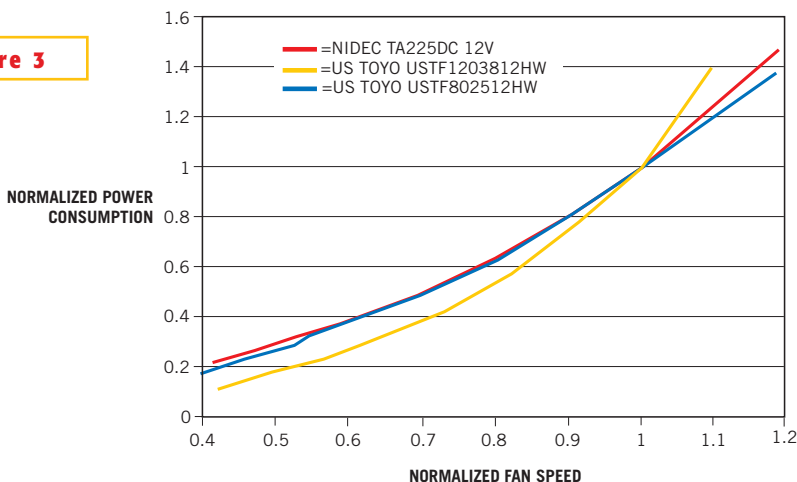

NOTE:
SPEED RELATIVE TO OPERATION AT 12V, USING 12V FANS.

Overall power consumption increases roughly with the square of the fan speed, so lower speeds produce considerable power savings.

knows, electronic equipment attracts dust, especially systems with fans. As dust collects at the inlet and exhausts of systems with fans, airflow can decrease or stop, which can result in reduced cooling and increased temperatures. Reducing the fan's speed can help remedy this problem.

You can design speed-control methods using either a high- or low-side-drive transistor, shown in the variations of **Figure 4**. High-side-drive transistors require slightly more complex circuitry than low-side-drive transistors because of level translation. However, high-side-drive transistors have the advantage of keeping the fan's negative terminal at ground.

Low-side-drive transistors, on the oth-

er hand, requires a translation for speed and alarm sensors.

STARTING WITH PWM

Methods for speed control offer many options, but you should consider that each method has different cost-versus-performance trade-offs. One possible method involves PWM (pulse-width modulation). You can pulse-width modulate the fan directly when you turn on and off the fan's power supply at a fixed frequency. Duty-cycle adjustments control the speed of the fan. The larger the duty cycle, the faster the fan spins. Picking the appropriate frequency for this method can be tricky. If the frequency of the PWM signal is too slow, the fan's

speed oscillates noticeably within a PWM cycle.

On the other hand, the frequency should not be too fast. Remember that commutation operates using electronics powered from the fan's plus and minus terminals. If you use PWM on the fan and the internal commutation electronics too quickly, the fan may stop operating. (Appropriate frequencies are 20 to 160 Hz.)

Advantages of PWM include a simple drive circuit, good start-up characteristics, and minimal heat dissipation in the pass transistor (Figure 4). Unfortunately, the PWM method has some shortcomings. It increases fan stress and is incompatible with speed or alarm sensors. These sensors are powered by the same supply voltage as the motor. Because the supply voltage powers on and off at 20 to 160 Hz, the speed and alarm circuitry is also powered up and down, which renders it useless.

During PWM control, the voltage the controller applies to the fan is either its rated voltage (12V in the case of a 12V fan) or 0V. However, because the fan spins at less than its rated speed, its back EMF is reduced, which causes higher than nominal current flow through the windings during the "on" period of the PWM cycle. As a result, the fan's speed may be adversely affected. Despite these disadvantages, PWM control may be appropriate for low-cost, noncritical applications.

Figure 4

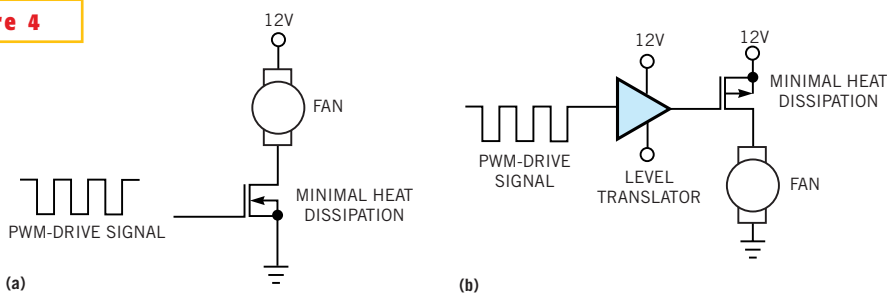

Low-side fan control (a) differs only slightly from high-side control (b), but practical differences in components are more significant.

age across it is nearly zero, which means zero power dissipation. During minimum cooling, the pass element is off (zero current flows), so, again, power dissipation is zero. You can approximate the current draw of the fan as a linear function of the voltage applied, making it appear resistive. Worst-case power dissipation occurs roughly when the voltage across the fan is half its maximum operating voltage (Figure 5). You can use the following equation to estimate worst-case power dissipation: $P = \frac{1}{4}(V_{MAX} \times I_{MAX})$, where I_{MAX} and V_{MAX} are the rated voltages and currents of the fan respectively. For example, a 1.2W fan (12V at 98 mA) has worst-case power dissipation across the pass element of only 300 mW when you run it at 6V with a 12V supply.

Start-up and stall problems are similar. Fans require a certain voltage before they can start. When a fan is spinning, decreasing the voltage to less than the stall

voltage causes the fan to stop. The start-up voltage is always equal to or greater than the stall voltage. Typically, these voltages are 25 to 50% of the rated voltage for the fan. When you use linear regulation without speed monitoring, you cannot determine whether a fan has stalled or even started.

There are several approaches to solve this problem. The first is to prevent voltages across the fan from decreasing lower than the start-up voltage. Although you can avoid this problem in software, selecting the correct voltage to ensure proper start-up for all fans and accounting for aging can limit the useful range of speed control. You might have to pick a minimum worst-case voltage of 60% nominal to ensure that all of the fans start. This approach can be wasteful considering you can most likely control the average fan down to 40%. As a second option, you can use a fan with a tachome-

LINEAR REGULATION

As its name implies, linear regulation adjusts the dc voltage across the fan using a linear regulator. When you use this method, you must ensure the fan is specified to operate over a range of voltages. Unlike PWM, linear regulation allows the use of speed and alarm sensors. Unfortunately, linear regulation also has its disadvantages, including power dissipation in the pass element and startup and stalling problems.

Linear regulators control the dc voltage across the fan by dissipating power in the form of heat. During maximum and minimum cooling, power dissipation is ideally zero. During maximum cooling, the pass element is fully on, so the volt-

Figure 5

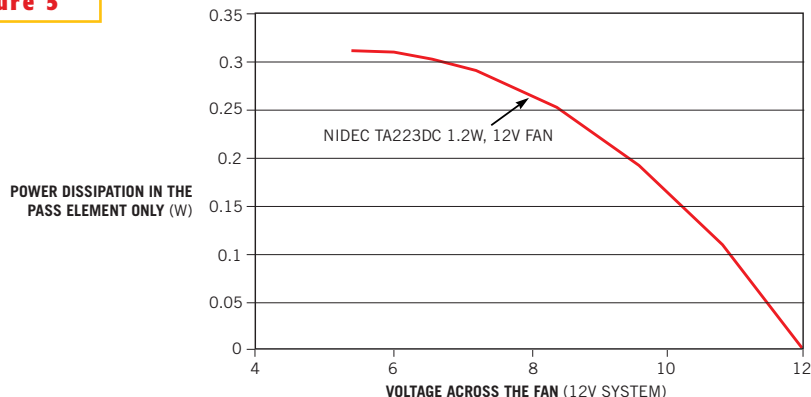

In linear regulation, you need to look closely at the dissipation of the pass element versus the voltage across the fan.

ter. A microcontroller monitors the tachometer, and the software indicates whether the fan starts or stalls. Although the tachometer option is more robust and less wasteful, it requires design time and additional hardware/software resources.

DC/DC REGULATION

Unlike linear regulators, dc/dc regulators use switch-mode power supplies to control the dc voltage across the fan. They are ideally 100% efficient and generate no heat (real-world efficiencies are generally 75 to 95%). The penalty for this efficiency is increased cost and complexity (Figures 6a and 6b). Although dc/dc regulators are more efficient than linear regulators, full-speed fan operation offers minimal power savings (Figure 7).

DC/DC regulators produce noticeable gains only when you significantly reduce fan speeds from their maximum value. Maximum-efficiency benefits occur when the voltage across the fan is half the maximum available voltage. Because of the increased cost and complexity of dc/dc converters and their limited power savings, dc/dc regulators usually operate in battery-powered systems or systems that include high-power fans or a large number of fans.

Figures 8 and 9 provide two examples of fan circuits targeting systems that don't require an alarm or speed sensor. In Figure 8, the MAX1669 is configured to drive the fan in PWM mode, and in Figure 9, the same IC is configured for dc linear mode. The circuit is both a temperature sensor and a fan controller. These two functions work independently and are intended to be used with a microcontroller. The MAX1669 and the microcontroller communicate via an SMB interface, a two-wire serial interface similar to and usually backward compatible with the I²C interface.

Temperature sensing occurs externally with a remotely mounted diode. Some IC vendors incorporate this diode directly on their die. In the case of Xilinx's Virtex family of parts, the connection to

Figure 6

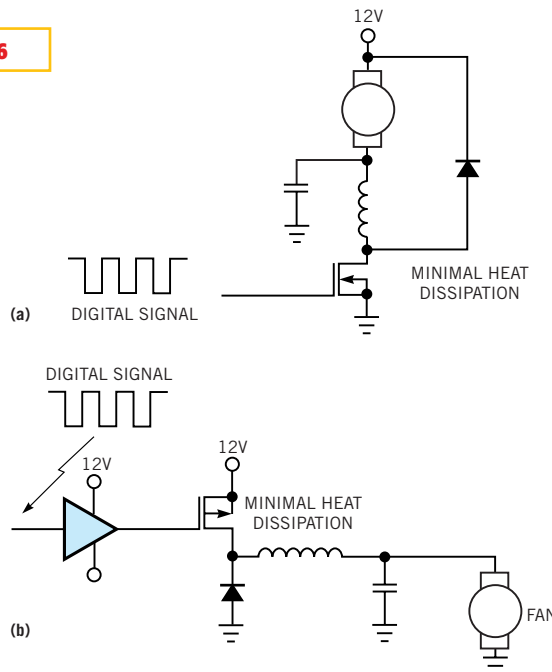

For dc/dc regulation, low-side control (a) looks quite different than high-side control (b).

the diode is labeled DXN and DXP. If you connect the MAX1669 directly to these pins, the circuit can measure die temperature directly, which allows the fan circuit to more tightly control the die temperature of an IC. The result is fewer worries about mounting temperature sensors to IC packages, determining thermal time constants, and calculating thermal resistance.

You can run the fan circuit in either an open- or closed-loop system with respect to temperature. If you run the circuit as an open-loop system, you can use the temperature sensor to measure ambient temperature if you mount the sensor at

the inlet of the unit. As the ambient temperature rises, the software increases fan speed. In this configuration, increasing or decreasing the fan speed ideally has no effect on the measured temperature. Thus, the system has no form of thermal feedback and is an open-loop system. Open-loop systems eliminate stability problems and allows for simpler software design.

You create a closed-loop system by placing the temperature sensor in a location that the fan is designed to cool. Increasing fan speed results in a drop in the measured temperature. You can ensure direct and tight control of your heat source if you closely consider stability issues. Tighter temperature control of your critical components means

you can regulate fan speed to the minimum speed necessary. Additionally, you can compensate for problems such as partially clogged inlets and outlets.

An IC such as the MAX1669 works well in low-end systems that do not have a high premium on reliability. However, for systems in which reliability is more critical, such circuits can fall short. In the case of open-loop-temperature control, the system is unable to detect fan failure. You can use elevated temperatures in closed-loop control as an indication, but there is still room for improvement. Elevated temperatures indicate a system problem but not a specific problem, such

Figure 7

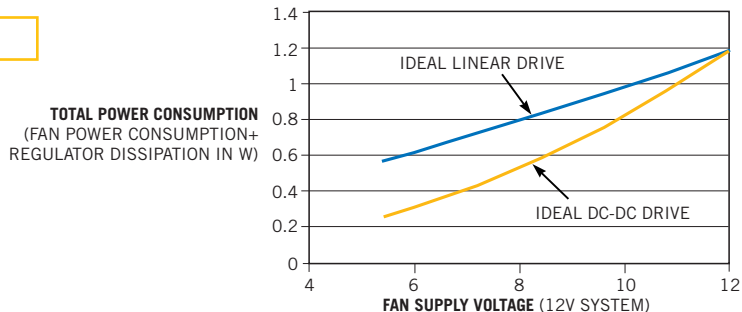

The difference between dc/dc-drive efficiency and linear-drive efficiency decreases as fan speed increases.

Figure 8

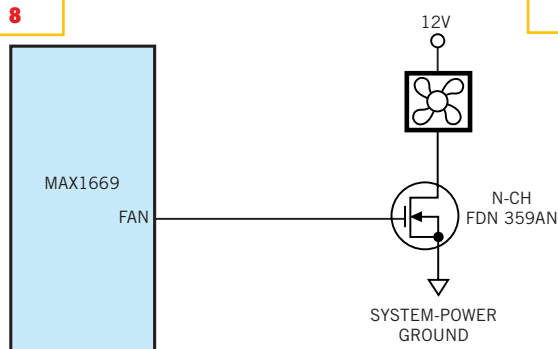

You can use a controller such as the MAX1669 to drive the fan in PWM mode with few external components.

Figure 9

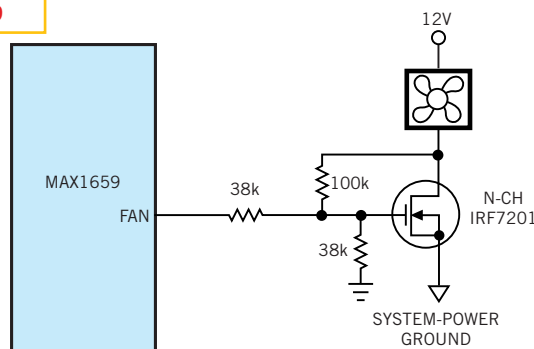

For operation in linear mode, the MAX166 needs a few more discrete components.

as clogged inlets and outlets, high ambient temperatures, excessive internal heat dissipation, or fan failures. In addition, slow thermal response delays noticeable signs of problems.

Tachometer outputs (speed sensors) can address these issues. **Figure 10** shows a circuit that uses a fan with a tachometer. The MAX6625 measures the temperature and reports it to the microcontroller via an I²C-compatible, two-wire interface. The same two-wire interface issues commands to the MAX6650, which controls fan speed. You can read fan speed over the SMB interface as a byte-wide integer.

You can configure the MAX6650 to work as a fan-speed controller or a fan-speed regulator. The difference is subtle but important. A fan-speed controller directly regulates the voltage across the fan. In contrast, a fan-speed regulator uses the fan's tachometer to measure and regulate the speed of the fan. When you directly configure the MAX6650 as a fan-speed controller, a microcontroller reads the temperature from the MAX6625 and the fan speed from the MAX6650 via the SMB interface. The microcontroller then issues DAC codes to the MAX6650. These DAC codes directly control the voltage across the fan and indirectly control fan speed. The microcontroller must constantly read the fan speed via the MAX6650 and make adjustments to the DAC to regulate the speed.

When you configure the MAX6650 as a fan-speed regulator, the microcontroller issues speed commands. The circuit automatically monitors and adjusts the speed of the fan to keep it within regulation. Once the fan operates at the

speed you desire, the microcontroller no longer plays a role in the process. If the MAX6650 cannot maintain the speed you want, you can configure the circuit to generate an alarm to the microcontroller. Note that in a temperature-closed-loop system, you have two closed loops (one for temperature regulation and one for fan-speed regulation), so you must take care to prevent instability problems.

When your fan-speed control relies on a microcontroller, your system's cooling is subject to software failures and bugs, so you should design in a backup control system. For example, you can use a small, inexpensive digital-output temperature sensor, such as the MAX6501, as a backup sensor. You can configure the MAX6650 to monitor the output of the MAX6501. If the MAX6501 trips due to high temperatures, the fans automatically turn on full, independent of software commands. This approach also protects your system against primary-temperature-sensor or microcontroller-hardware failure.

MULTIPLE FANS

In some situations, you need to control multiple fans as a single group by running the fans parallel. Because the three fans run in parallel, independent speed regulation of each fan is impossible. One fan must be a master, around which any speed-regulation loop is closed. In speed-regulation mode, an IC such as the MAX6651 closes the speed loop around the fan connected to Tach 0. When you use the MAX6651 as a fan-speed controller, the microcontroller can close the loop around any one of the four fans. Al-

though the MAX6651 does not directly regulate the speed of the remaining fans, if you use identical fans, they will run at similar speeds. To ensure the unregulated fans are working properly, the MAX6651 allows the microcontroller to read the speed of each fan via the SMB interface.

N+1 AND HOT-SWAP APPLICATION

When a problem occurs with a fan, you can sometimes shut down the system to prevent damage. However, for systems which need to minimize downtime, shutdown is an unattractive option. To prevent shut down you can use N+1 topology, which is the practice of using one more fan than you need under worst-case conditions. This technique allows sufficient cooling if one fan fails. In addition, you should place all fans on separate cards to minimize hot-swapping in and out so that you can remove and replace a defective fan while the unit is running, preventing downtime.

In an N+1 circuit, you can configure the MAX6651s to automatically force all working fans to run at their maximum speed if any fan fails.

Systems that use multiple fans may experience an additional source of acoustic noise because of beat frequencies between fans. Similar to the effect experienced in multiple-engine airplanes, two fans that are spinning at similar but slightly different speeds cause a beating noise with a frequency related to the difference in speed. This effect can be subtle, and in most systems it is not a concern. However, you may want to eliminate as much noise as possible with higher-end systems. In a system that uses

multiple MAX6651s as fan-speed regulators, you can spin the fans at exactly the same speed by configuring all the controllers to use the same oscillator. You can employ a master/slave architecture by setting up the first controller as a clock output and the remaining circuits as clock inputs. With all parts running on the same clock, speed tolerances tightly keep noise to an absolute minimum. □

AUTHOR'S BIOGRAPHY

Bruce Denmark is a field applications engineer for Maxim Integrated Products. Before joining Maxim six years ago, Denmark worked as a design engineer for SAIC for seven years. He began his engineering career at Datagraphics after receiving a BSEE from Lehigh University, Bethlehem, PA in 1985. Denmark's spare-time interests include basketball, cycling, weight lifting, and SCUBA. You can contact him at Bruce_Denmark@Compuserve.com.

Figure 10

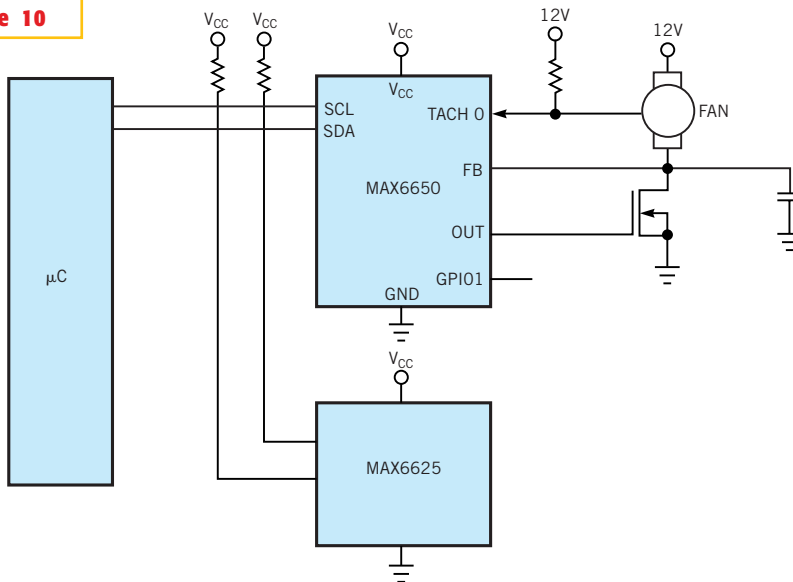

Adding a tachometer allows you to close the loop around the fan speed variable using a MAX6625 temperature-interface IC.