



The quest for high efficiency in LOW-VOLTAGE SUPPLIES

**A NEW GENERATION OF SYNCHRONOUS-RECTIFIER MOSFETS AND DC/DC-CONVERTER ICs
MAKE IT POSSIBLE TO ACHIEVE HIGH EFFICIENCY IN LOW-VOLTAGE POWER SUPPLIES.**

At a glance58

*UPS ups 3- Φ conversion
efficiency*58

For more information60

AS LOGIC-IC AND CPU VOLTAGES DROP from 5 to 3.3V and ultimately to 1V, it becomes increasingly difficult for power supplies and local dc/dc converters to efficiently do their job. Losses in rectification elements become more prominent in the efficiency equation. Simple diode rectifiers with their 0.5V or so forward drop are out of the question. The conversion technique of choice in low-voltage systems is synchronous rectification, in which power MOSFETs take the place of the diode rectifiers. A MOSFET makes a near-

ideal rectifier, because the forward voltage is solely a function of the transistor's $R_{DS(ON)}$. MOSFET manufacturers are continually lowering the $R_{DS(ON)}$ of their devices and offering matched pairs, with the upper and lower MOSFETs optimized for maximum rectification efficiency. At the same time, IC makers are developing circuits—notably, multiphase dc/dc converters—that squeeze the last possible

drop of efficiency from power-supply circuits.

International Rectifier (IR) has entered the second phase of its “dc/dc road map,” a program to develop semiconductors that maximize the attainable efficiency of isolated-converter and buck-dc/dc-converter topologies in low-voltage systems.

“With currents escalating as supply voltages drop, designers are increasingly

challenged to implement efficient distributed power supplies at the heart of servers, routers, and telecomm equipment, as well as Internet appliances and even 1-GHz PCs,” says IR CEO Alex Lidow. The new power semiconductors from IR and others keep isolated dc/dc converters using dual-stage, bridge, and single-forward topologies with sub-2V outputs operating at maximum efficiency.

AT A GLANCE

- ▶ You face many trade-offs in selecting synchronous-rectifier elements.
- ▶ Multiphase dc/dc converters ease the task of filter capacitors.
- ▶ Boost circuits prolong battery life through high conversion efficiency.

The devices also come in component sets for multiphase buck converters to wring the last possible percentage of efficiency from the inherently efficient multiphase topology.

SYNCHRONOUS BUCK CONVERTERS

An efficient, low-voltage synchronous buck, or step-down, converter is difficult to design because the ratio of output

UPS ups 3- Φ conversion efficiency

In facilities that use substantial amounts of power, the electrical contractor or facilities manager often opts to use three-phase power to optimize load balancing within the site. In situations in which power outages can cause major problems, a UPS (uninterruptible power supply) is a necessary adjunct to the system. UPS units that provide three-phase power have a number of characteristics different from line-interactive, single-phase UPS devices usually used for networking applications. First, three-phase UPSs rated at 10 kVA or higher

are online systems; that is, the converters, inverters, and battery within the UPS supply all the power to the load all the time. Smaller, single-phase UPSs kick in only when the power line fails.

Traditionally, UPSs for three-phase applications have used *double-conversion* technology (Figure A). A rectifier circuit receives ac power from the utility line and generates dc power to keep the battery charged. At the same time, the rectifier section provides dc power to the inverter, which delivers regulated ac power to the load. When the utility

input fails, the battery supplies power to the inverter until the utility power is again available. All these transitions occur with no interruption in the flow of power to the load.

A major problem with traditional double-conversion UPSs relates to power factor and harmonics. The high-power switching that occurs during normal operation generates substantial harmonic currents, which enter the utility line upstream from the UPS. This harmonic distortion degrades the voltage quality on the power line and can cause a variety of disturbances within the affected facility. These disturbances include blinking lights, tripped circuit breakers and blown fuses without apparent cause, malfunction of computers, interference in radio communications, and transformer failures.

To address the issues of low power factor and harmonic distortion, Silcon, a division of American Power Conversion Corp (www.apcc.com) employs the *delta-conversion* UPS topology (Figure B). A delta-conversion online UPS does not use an ac-to-dc-to-ac conversion process. Instead it uses two bidirectional converters that can pass power in either direction. Both converters connect to a common battery. Converter 1 is rated at approximately 30% of the output power of the UPS. It connects in series between the utility line and the load. Converter 2 is rated for the full UPS-power load.

Under normal ac-line condi-

tions, power from the utility line passes to the load using an ac-to-ac conversion via Converter 1. Because the UPS does not convert the power twice (rectifier and inverter), little power is wasted. The converters are in full control of the output power to the load and also control battery charging. When a power failure occurs, the delta-conversion system instantaneously takes power from the battery through Converter 2 and delivers it to the load. Converter 1, called the delta converter, compensates for any differences between the UPS output voltage and the utility voltage. It also controls the input power factor by ensuring that the utility sees current that is sinusoidal and in phase with the utility voltage. Converter 1 also assumes the task of battery charging.

MGE UPS Systems (www.mgeups.com) also uses the delta-conversion topology in its high-power, three-phase UPS systems. For example, the Galaxy 3000 Series of 10- to 30-kVA systems attains 97% efficiency, as do the cited Silcon systems. Double-conversion systems can waste as much as 12% under normal operating conditions. This reduced power wastage means a delta-conversion UPS can pay for itself in the form of power savings in a few years. Perhaps more important, the delta-conversion UPSs offer efficient power-factor correction and eliminate switching harmonics.

Figure A

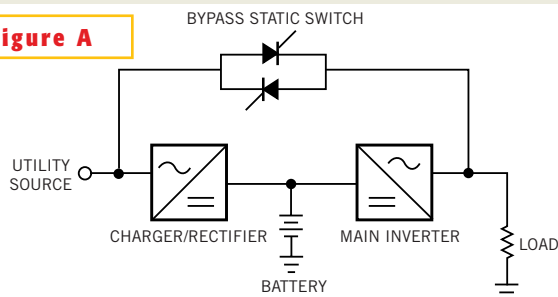

A double-conversion UPS wastes power, in that it performs two conversions: ac to dc, then dc to ac.

Figure B

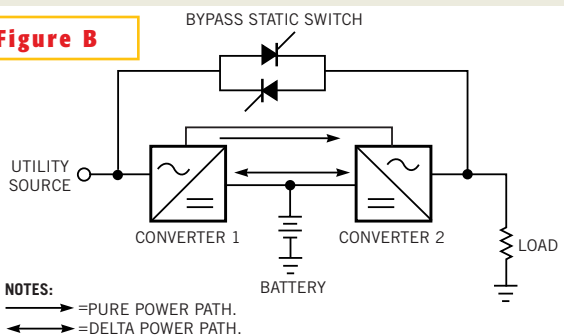

A delta-conversion UPS usually operates ac-to-ac; therefore, it wastes minimal power.

voltage to input voltage is directly proportional to the duty cycle of the power MOSFETs (**Figure 1**). The lower the output voltage goes, the longer the synchronous rectifier, Q_2 , must conduct, and the more critical the switching losses of Q_1 become. In some systems, the duty cycle is 95% for Q_2 , and 5% for Q_1 . In some cases, the on-resistance required for the synchronous rectifier is so low, designers have to use two MOSFETs in parallel. But using parallel devices is inimical to the trend toward smaller and smaller footprints in systems. As stated, the upper MOSFET operates with a low duty cycle. The critical parameter of this device is the switching characteristic. The parameter to optimize in this device is the switching charge, Q_{sw} . This charge is the culprit that creates power dissipation in the upper MOSFET. The product of Q_{sw} and $R_{DS(ON)}$ is known as the “figure of merit” for the control FET. MOSFET manufacturers’ challenge is to reduce Q_{sw} and $R_{DS(ON)}$. This challenge is a daunting one for silicon designers, because reducing one parameter usually results in increasing the other.

The lower MOSFET, the synchronous rectifier, has another set of optimization criteria. Because the duty cycle for this device is extremely long and peak currents can be high, it is important to keep $R_{DS(ON)}$ as low as possible. Switching-loss

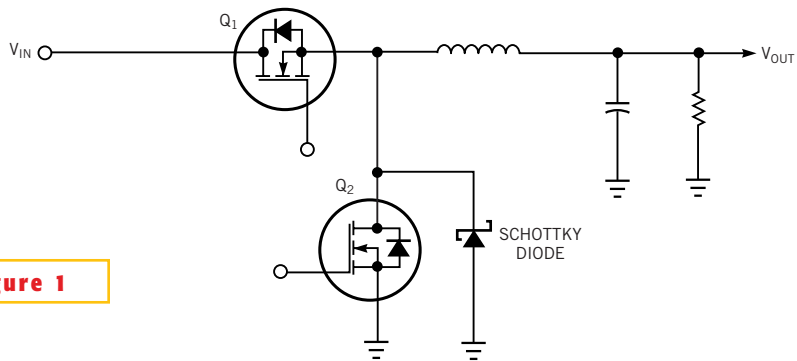

Figure 1

A synchronous-rectifier circuit substitutes power MOSFETs for the diode-rectifier elements; the result is lower losses.

considerations are less crucial for this device, because it operates under a ZVS (zero-voltage-switching) condition. However, some secondary optimization criteria exist for this MOSFET. High-frequency dc/dc converters can have problems with unintended turn-on of the synchronous FET. When the upper FET turns on, the voltage on the switch node (source of the upper FET and drain of the lower FET) rises at a certain rate, dV/dt . The dV/dt can be fast enough that it can couple with the parasitic capacitance C_{GD} of the lower FET, such that it produces a voltage spike on the gate of the lower FET (**Figure 2**). If this spike is greater than the threshold voltage, the

synchronous FET turns on. In this condition, both the upper and the lower FETs conduct, and a huge shoot-through current results. You can prevent unintended turn-on of the synchronous FET by optimizing the charge ratio in the FET. If $Q_{GD}/Q_{GS} < 1$, unintended turn-on does not occur. You can use PSpice to analyze the performance of power MOSFETs in synchronous-rectification circuits (**Reference 1**).

The synchronous-buck topology also uses a Schottky diode in parallel with the synchronous FET. This addition improves efficiency during dead time, the built-in delay between turn-on of the two FETs that prevents cross-conduction.

FOR MORE INFORMATION...

For more information on components for low-voltage power supplies such as those discussed in this article, enter the appropriate numbers at www.ednmag.com/infoaccess.asp. When you contact any of the following manufacturers directly, please let them know you read about their products in *EDN*.

Analog Devices Inc

www.analog.com
Enter No. 321

Fairchild Semiconductor

www.fairchildsemi.com
Enter No. 322

Infineon Technologies

www.infineon.com
Enter No. 323

International Rectifier

www.irf.com
Enter No. 324

Intersil Corp

www.intersil.com
Enter No. 325

Linear Technology Corp

www.linear-tech.com
Enter No. 326

Maxim Integrated Products

www.maxim-ic.com
Enter No. 327

National Semiconductor Corp

www.national.com
Enter No. 328

On Semiconductor

www.onsemi.com
Enter No. 329

Philips Semiconductors

www.semiconductors.philips.com
Enter No. 330

Semtech Corp

www.semtech.com
Enter No. 331

ST Microelectronics

www.st.com
Enter No. 332

Telcom Semiconductor

www.telcom-semi.com
Enter No. 333

Texas Instruments

www.ti.com
Enter No. 334

Vishay Siliconix

www.siliconix.com
Enter No. 335

SUPER INFO NUMBER

For more information on the products available from all of the vendors listed in this box, enter No. 336 at www.ednmag.com/infoaccess.asp.

During dead-time conduction, the current flows through the Schottky diode instead of the body diode of the FET. The forward voltage of the Schottky diode, V_F , contributes to dead-time power loss. So it is important to minimize both V_F and the inductance associated with the parallel connection of the diode. IR has taken all the cited optimization criteria into account in its IRF7901 Dual FETKY device, a high-side control FET, a low-side synchronous FET, and parallel Schottky diodes in a single SO-8 package. This 30V chip set can yield efficiencies as high as 87% in applications requiring 1V output at currents to 5A. IR also offers a complete design kit, the IRNBPS2, that allows you to compare discrete and Dual FETKY performance on the same board for multiple output voltages.

Fairchild Semiconductor also has a road map for synchronous-rectification devices. Its 30V FDZ5047N BGA-packaged MOSFET lays claim to the industry's lowest $R_{DS(ON)}$: 2.5 m Ω typical, 3.5 m Ω maximum. With a thickness of just 0.8 mm, the device is five times thinner than a TO-263, three times thinner than a DPAK, and half the thickness of an SO-

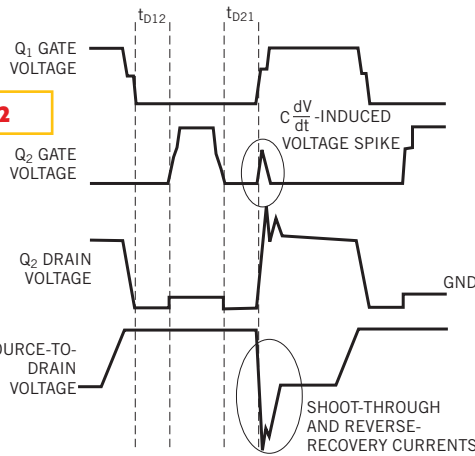

Figure 2

In a synchronous rectifier, you must take care to prevent cross-conduction from CdV/dt -induced spikes on the gate of the lower MOSFET.

8. The company also claims that, by virtually eliminating the package resistance, the FDZ5047N offers the industry's best figure of merit— $Q_{SW} \times R_{DS(ON)}$ of 225 nC·m Ω , versus the 540 nC·m Ω for competitive devices with similar $R_{DS(ON)}$. The MOSFET comes in 5×6- and 5×5.5-mm sizes. The 5×6-mm package offers the lowest $R_{DS(ON)}$, but it requires multilayer pc-board routing to connect to the gate. The larger package is easier to route in a single-sided pc-board

layout, because it has drain contacts on only three sides.

Fairchild also recently announced the SyncFET, an integrated Schottky diode and a MOSFET on one die. The company claims the integrated chip offers significant advantages over discrete or copackaged, multichip devices. First, integrating the Schottky diode directly into the silicon allows using the entire package area for the MOSFET, resulting in a performance advantage over typical multichip assemblies. Integration also reduces EMI/RFI, because high-frequency currents need not flow through bond wires and pc-board traces between an external Schottky diode and the MOSFET. The FDS6982S combines a 12-m Ω low-side SyncFET

and a 21-m Ω low-gate-charge, high-side MOSFET in an SO-8 package. The device provides a single-package option for dc/dc-converter designs for currents as high as 7A.

On Semiconductor, Intersil, Vishay Siliconix, ST Microelectronics, Philips, and Infineon are also addressing the synchronous-rectifier market. In addition to low-voltage, synchronous-rectifier MOSFETs, Infineon has announced a line of MOSFETs using CoolMOS C2 technolo-

Figure 3

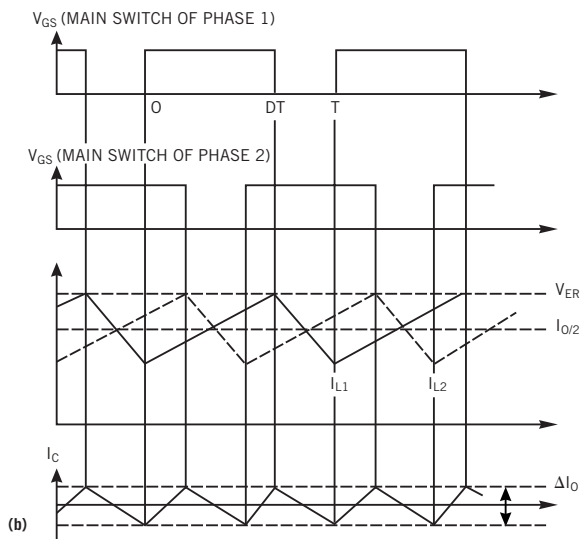
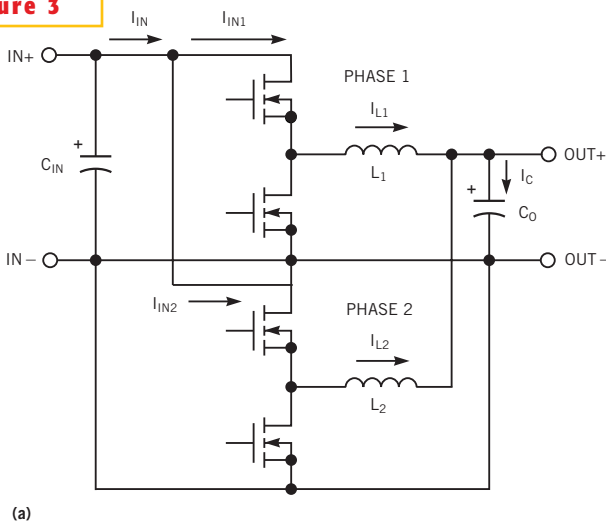

In a multiphase converter (a), the operating frequency is essentially doubled (b), resulting in less stringent requirements on the input and output capacitors.

gy. The 600V technology enhances efficiency in switch-mode and uninterruptible power supplies by defying an old law of semiconductor physics. Traditionally a MOSFET's $R_{DS(ON)}$ was a nonlinear function of the voltage rating of the device. $R_{DS(ON)}$ was proportional to approximately the 2.5th power of the voltage rating. The company has introduced vertical p-stripes to compensate the highly doped n-stripes between p regions. The folded structure reduces area-specific $R_{DS(ON)}$ by a factor of five. The result is an almost linear relationship between $R_{DS(ON)}$ and voltage rating.

MULTIPHASE CONVERTERS

Systems requiring supply currents of 100A or more are becoming relatively common. A power supply to meet such demands usually requires the parallel connection of several power regulators to alleviate the thermal stresses on the power components. A power-supply designer must decide how to drive these regulators: with a brute-force, single-phase system or a multiphase supply. A multiphase converter interleaves the clock signals of the paralleled output stages and thereby reduces input and output ripple current without increasing the switching frequency (Reference 2). The reduced power loss from the ESR of the input capacitor and the low switching losses of the MOSFETs at the relatively low switching frequencies help achieve high conversion efficiency. The technique also allows the use of lower value inductors at the output.

SYSTEMS REQUIRING SUPPLY CURRENTS OF 100A OR MORE ARE BECOMING RELATIVELY COMMON.

Figure 3 illustrates the operating principles of a two-phase converter.

Peak-current-mode control requires that the high-side switch turn off when the peak inductor current (I_{L1} , I_{L2}) intercepts the error voltage, V_{ER} , resulting in equal peak inductor currents. If the inductors are identical, then the peak-to-peak ripple currents of the inductors are the same. The dc currents in the two inductors, which are the peak current minus half the peak-to-peak ripple current, are equal for the two inductors. The two channels, or phases, thus share the load current equally. You can extend the same current-sharing principle to any number of channels, or phases. The phase relationship of Figure 3b shows how ripple-current cancellation works. Because of the 180° phase difference between the two channels, the two inductor ripple currents tend to cancel each other, causing a smaller ripple current to flow into the output capacitor. The frequency of the output ripple current is doubled as well. All these factors contribute to a smaller output capacitor for the same ripple-voltage requirement.

Several IC manufacturers offer multiphase dc/dc converters. Linear Technology's LTC1629 is a two-phase controller that uses the cited current-mode control to ensure equal current sharing in the two channels. The IC has two differential (floating) sensing inputs that sense the load current in low-value (for example, 3 mΩ) series resistors. You can connect as many as six LTC1629s to obtain additional phases, for as many as 12 evenly phased controllers for systems requiring 15 to 200A output current. Typical operating frequency for the LTC1629 is 250 kHz (310 kHz maximum), resulting in a 1.8-MHz effective switching frequency for a 12-phase controller. Another two-phase controller from Linear Technology uses 5-bit VID (voltage-identification) codes to set the output voltage. The LTC1709, like the LTC1629, accepts input voltages of 4 to 36V and delivers output voltages of 1.3 to 3.5V in 50- and 100-mV increments, according to the VID code.

Intersil also offers a VID-controlled multiphase controller. The HIP6301 integrates four channels that allow you to choose two-, three-, or four-phase operation. The IC works from a 5V input, and delivers a 1.1 to 1.85V output in 25-mV increments, according to the VID code. The HIP6301 has a power-good monitor circuit, whose output stays low until the μP core voltage increases during a soft-start sequence, to within 10% of the VID-programmed voltage. An overvoltage condition, 15% above the programmed voltage, results in converter shutdown, plus clamping the lower MOSFET on to protect the μP. National Semiconductor's LM2639 VID-controlled, multiphase controller offers two-, three-, or four-phase operation. The LM2639 operates at a nominal frequency of 2 MHz, resulting in an 8-MHz equivalent frequency for four-phase operation. Semtech's SC1146 is another recently announced VID-controlled multiphase controller. It offers selectable two-, three-, or four-phase operation. The SC1146 operates from a resistor-programmable master clock as fast as 8 MHz. As a final example of multiphase buck converters, the VID-controlled ADP3160 from Analog Devices offers two-phase operation. The IC's PWM outputs drive companion ADP3412 syn-

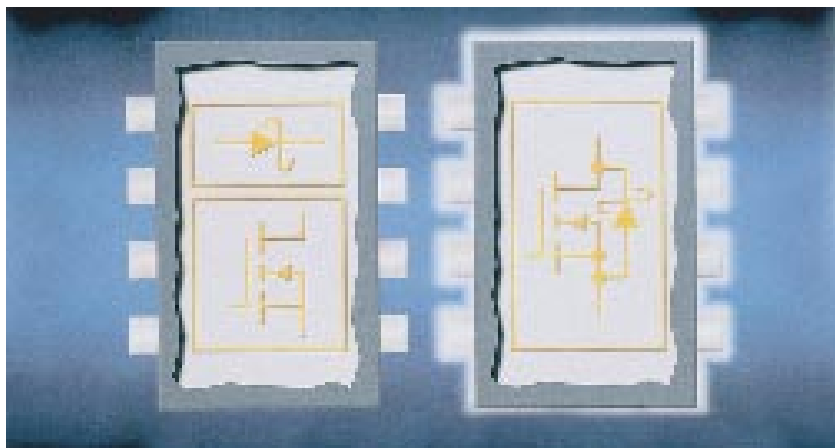

A Schottky diode and a power MOSFET occupy a single die in synchronous rectifiers from Fairchild.

chronous-driver ICs to control the external MOSFETs.

VARIOUS ICs STRIVE FOR EFFICIENCY

The benefits of multiphase controllers notwithstanding, single-phase PWM controllers still offer a means of high-efficiency conversion. On Semiconductor's MC33470 controller, for example, drives a synchronous-rectifier output stage. The VID-controlled IC provides high output drive with sink and source saturation voltages of 0.5V typical for the external MOSFETs. The output drivers provide 100-nsec dead time, to prevent cross-conduction (shoot-through) of the external MOSFETs. The MC33470 offers a soft-start control, in which an external capacitor and an internal 10- μ A current source control the rate of voltage increase at the error-amplifier output, thereby establishing the circuit's turn-on time. Maxim Integrated Products offers two highly efficient voltage-conversion ICs that need no external switches. The MAX1644 (Figure 4) is a 2A dc/dc converter that incorporates 0.1 Ω n- and p-channel MOSFETs for synchronous rectification. The IC offers a pin-selectable 2.5 or 3.3V output; alternatively, you can opt for an adjustable output between 1.1V and V_{IN} .

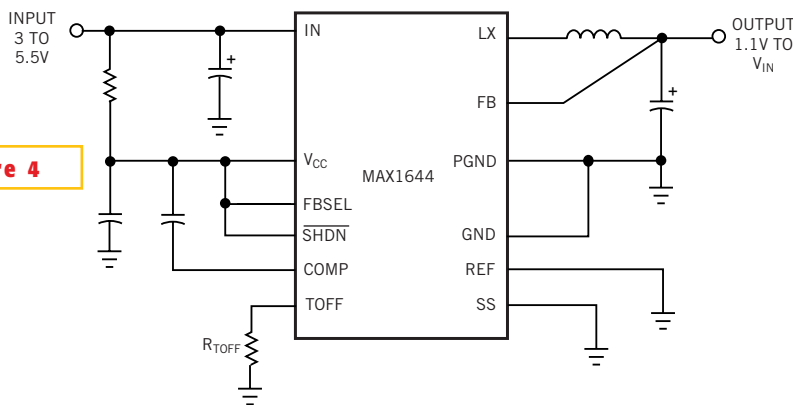

Figure 4

A self-contained circuit from Maxim provides synchronous rectification without the need for external MOSFETs.

Curves in the data sheet show peak efficiencies of approximately 95% with 3.3V output and 93% with 1.5V output. Texas Instruments makes an application-specific controller that targets DSP chips and μ Cs. The TPS56300 provides the core and I/O voltages; a trilevel VID code sets both regulated voltages to any of nine preset voltage pairs of 1.3 to 3.3V.

Another dc/dc converter from Maxim uses a step-down charge pump to provide inductorless conversion. The converter supplies a fixed, pin-selectable 1.8 or 1.9V output. A typical application of the IC is to generate a 1.8V core-logic supply from a 3.6V lithium-ion battery. Efficiency with a 3.3V input voltage is approximately 80% versus 50% for a linear regulator. Speaking of batteries, conversion efficiency is a crucial issue in portable equipment. A family of boost converters from Texas Instruments operates from a single or dual alkaline cell and provides greater than 80% efficiency over a wide range of conditions. The UCC3941 Series delivers outputs of 3.3 or 5V, depending on the model. A model with an adjustable output is also available. The converter targets applications using several milliwatts to several

hundred milliwatts, such as PDAs (personal digital assistants) and pagers. The IC owes its efficiency to an internal synchronous-rectifier circuit using on-chip FET switches. Telcom Semiconductor offers a high-efficiency voltage doubler that targets battery-powered systems. The TC1240 operates over an input range of 2.5 to 4V and doubles the input voltage with an efficiency greater than 99%.

Newly available MOSFETs and matched pairs thereof make it possible to achieve greater than 90% efficiency in low-voltage dc/dc converters. The matched synchronous-rectifier pairs both boost conversion efficiency and ease your design task. You can choose from a great variety of dc/dc-converter ICs to work with these efficient MOSFETs. Two important benefits accrue from the enhanced efficiency: less power wasted and less heat generated in the power supply. □

You can reach Senior Technical Editor Bill Travis at 1-617-558-4471, fax 1-617-558-4470, e-mail b.travis@cahners.com.

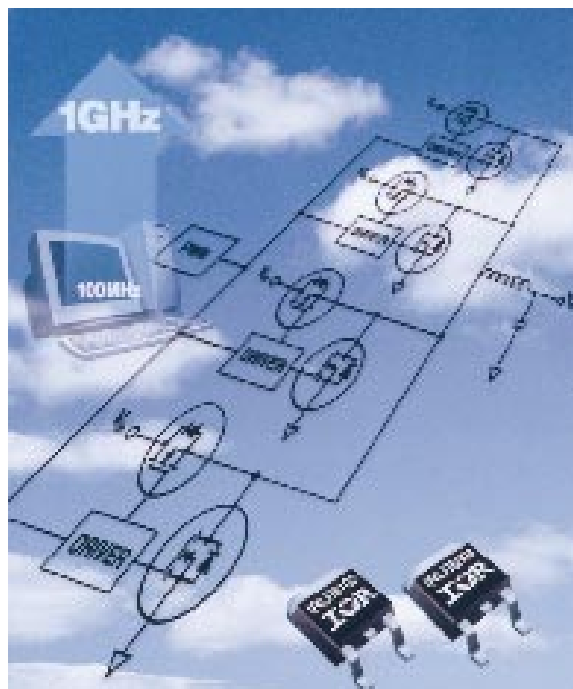
Synchronous-rectifier MOSFETs from International Rectifier are optimized as upper and lower switches.

REFERENCES

1. Honda, Rick, and Scott Deuty, "Using PSpice to Analyze Performance of Power MOSFETs in Step-Down, Switching Regulators Employing Synchronous Rectification," Application Note AN1631, On Semiconductor.
2. Chen, Wei, "High Efficiency, High Density, PolyPhase Converters for High Current Applications," Application Note 77, Linear Technology Corp.