

A REVIEW OF REFERENCE TOPOLOGIES AND A QUICK LOOK AT THE VARIOUS WAYS THAT MANUFACTURERS SPECIFY REFERENCES WILL HELP YOU PICK THE BEST PART FOR YOUR NEXT DESIGN.

A quick guide to voltage references

DESIGNERS OFTEN CHOOSE voltage references in haste, typically looking at the price, the initial accuracy that the data sheet highlights, and nothing else. However, as with all other components, you have to be careful to compare apples to apples when choosing a reference. When evaluating a specification from several data sheets, make sure all data-sheet specifications are expressed in the same units. Determine what parameters are important for your application and look beyond the initial accuracy specifications.

The first considerations in choosing a voltage reference clearly are output voltage and initial accuracy. Unfortunately, it's easy to overlook the various other data-sheet parameters that can assume major importance in specific applications. A short review of voltage-reference basics and the associated performance parameters of the most common voltage-reference topologies—the two-terminal-shunt and three-terminal series designs—make it easy to select your next reference.

REFERENCE TYPES: SHUNT AND SERIES

As its name implies, the shunt reference operates in parallel with its load (Figure 1). You can view this type of reference as a voltage-controlled current sink in which the controlling voltage drives the input terminal. With no load, the shunt reference sinks just enough current so the voltage drop across R_1 produces the desired output voltage: $V_{IN} - I_{REF} \times R_1 = V_{REF}$. If, for example, $V_{IN} = 6V$ and the desired V_{REF} is 5V, the reference current, I_{REF} , creates a 1V drop across R_1 . The reference then adjusts I_{REF} as necessary to maintain 5V across its input.

Now apply a load to the reference. I_{REF} no longer equals I_{R1} , because load current I_L produces part of the voltage drop across R_1 . The reference automatically reduces its sink current by the amount I_L . Thus, the total current through R_1 doesn't change; I_{REF} plus I_L equals the original I_{R1} . The circuit shunts I_{R1} be-

tween the reference and the load, hence the name "shunt reference." Thus, a shunt reference regulates the output voltage by adjusting its sink current to oppose changes in load current.

The series reference operates in series with its load (Figure 2). You can view this type of reference as a voltage-controlled resistance in which V_{OUT} controls an internal resistance between the reference's input and output terminals. A series reference regulates by creating a voltage drop between its input and its output, equal to the product of load current and the controlled internal resistance. With no load, the series reference draws a small amount of current, I_Q , through the internal resistance, R , to drop a voltage between input and output necessary to produce the correct V_{OUT} .

As load current increases, the reference maintains the desired output voltage by changing R as necessary to produce the correct drop between input and output. Applying Ohm's law, you can see that, to maintain a constant drop between input and output, R must decrease as I_{OUT} increases.

Figure 1

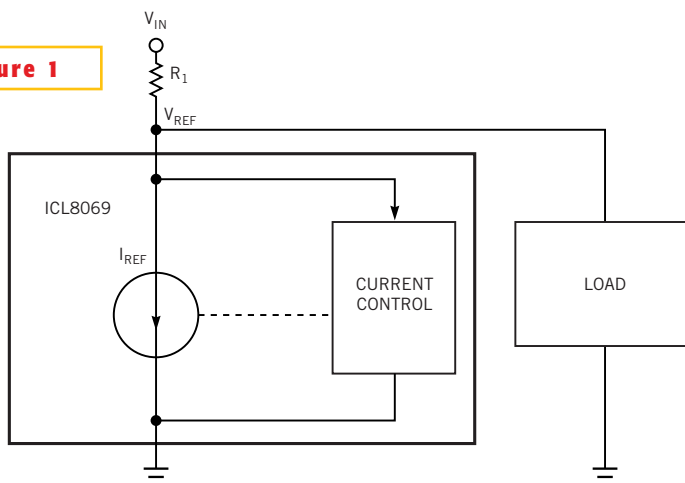

A shunt reference connects in parallel with its load.

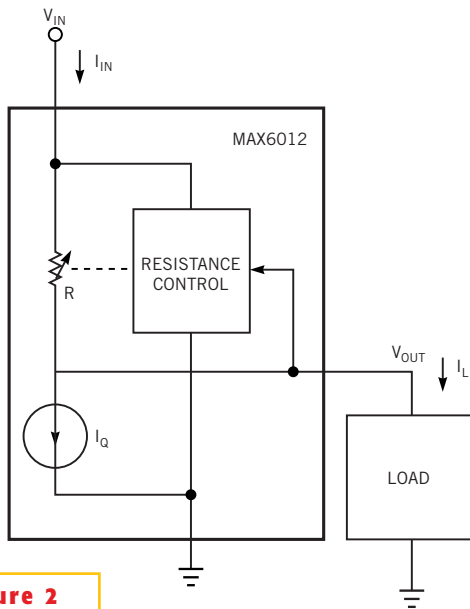

Figure 2

The regulating part of a series reference connects in series with its load.

The sidebar “Popular voltage-reference types” highlights the major pros and cons of the common types of shunt and series references.

CHOOSE YOUR ACCURACY UNIT

Manufacturers use different units to specify voltage-reference parameters, such as accuracy. For specifying accuracy, common units include parts per million, percentage, and voltage. All are acceptable, but to make apples-to-apples comparisons you must be able to convert one unit to any other.

The most common means for stating reference accuracy is as a percentage of the nominal value, which isn’t even a unit. This practice probably follows the convention for expressing tolerance on resistors, capacitors, and inductors. Typical percent-accuracy specifications for references are 1, 1.5, 2, and 5% and so on. Although percentage accuracy is fine for comparing one reference with another, it provides no specific information on how much the reference voltage deviates from nominal. What matters is the variation in volts.

To determine the voltage deviation of a reference specified in percentage accuracy, you multiply the nominal output voltage of the reference by the percentage accuracy and divide by 100. For example, a 2.5V reference accurate to $\pm 1.5\%$ has

the following voltage deviation:

$$\frac{\pm(2.5V \cdot 1.5)}{100} = \pm 0.0375V =$$

$$37.5 \text{ mV.}$$

Because the reference error can be above or below nominal, the total deviation is twice this value, or 75 mV. The total output-voltage variation equals the nominal voltage plus or minus the error voltage:

$$2.5V \pm 0.0375V =$$

$$2.4625V \Leftrightarrow 2.375V.$$

Knowing these voltage limits for the reference gives you design boundaries for the circuitry that the reference supports.

Another reference-accuracy unit you find in data sheets is parts per million. Manufacturers typically use this measure to specify temperature coefficients and other parameters that change little under varying conditions. For a 2.5V reference, 1 ppm is one-millionth of 2.5V, or 2.5 μV . If the reference is accurate to within 10 ppm, which is extremely good performance for any reference, its output tolerance is:

$$\frac{2.5V \cdot 10}{10^{-6}} = 25 \mu\text{V.}$$

You can convert this number to voltage accuracy as follows:

$$2.5V \pm 25 \mu\text{V} = 2.499975V \Leftrightarrow 2.500025V.$$

You can also express this accuracy as a percentage:

$$\frac{\pm(25 \cdot 10^{-6}) \cdot 100}{2.5V} = \pm 0.001\%.$$

Using the term “bits” as a unit, as in “16-bit reference,” is somewhat confusing. This unit leaves you wondering whether the specification represents an actual measurement of accuracy or whether it means that the reference is accurate enough for a 16-bit ADC. A 16-bit reference can be accurate to 1 or 2 LSBs, so this reference is not necessarily sufficient for a 16-bit system. On the other hand,

when a manufacturer states that a reference is “accurate to 16 bits” the specification includes hard numbers.

If the manufacturer specifies this unit using an actual measurement, then “accurate to 16 bits” is simply the value of the parameter divided by the claimed bit accuracy in decimals. For example, a 2.5V reference that a manufacturer claims to be 16-bit accurate, which is another extremely accurate tolerance for any reference, should deviate by no more than the decimal equivalent of 16 bits: $2^{16} = 65,536$, so 1 bit is $1/65,536$ of the total value. In this case, $2.5/65,536 \approx 38 \mu\text{V}$. If you assume 1-bit accuracy, or ± 1 LSB, the output voltage can be 1 bit higher or lower than nominal, or $\pm 38 \mu\text{V}$. You can convert this number to voltage accuracy:

$$2.5V \pm 38 \mu\text{V} = 2.499962V \Leftrightarrow 2.500038V.$$

Converting to a percentage,

$$\frac{\pm 38 \cdot 10^{-6}}{2.5} \cdot 100 = \pm 0.0015\%.$$

Figure 3

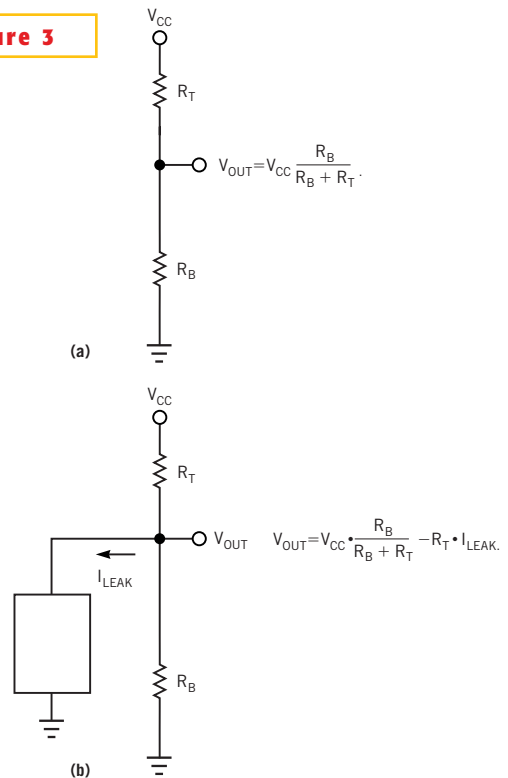

This simple resistor-divider analogy represents a voltage reference that’s unloaded (a) and loaded (b).

Overall specifications for a voltage reference list initial accuracy, temperature coefficient, temperature hysteresis, line regulation, load regulation, long-term drift, supply current, ground current, dropout voltage, and load capacitance.

Initial accuracy speaks for itself. If you take a part off the shelf, connect it in a test circuit, and measure the output voltage, the measured value should be within the initial-accuracy tolerance that the data sheet specifies. This specification usually applies at room temperature only and provides a starting point for most of the other specifications.

Temperature coefficient is the deviation of the reference's output voltage from nominal due to a change in the ambient or package temperature. Depending on the device structure and the way the manufacturer trims the output voltage during initial calibration, this output-voltage deviation can be positive, increasing with increasing temperature, or negative, decreasing with increasing temperature.

By analogy, consider a simple resistive voltage divider (**Figure 3a**). Voltage at the common point, V_{OUT} , is a fraction of the applied voltage, V_{IN} , equal to the ratio of the values of the two resistors. Both resistors change with temperature by the same percentage, maintaining a constant ratio, so V_{OUT} also remains constant.

Note that current flowing through the resistors varies with temperature, and any positive or negative leakage current from the common point of the divider changes V_{OUT} (**Figure 3b**). At room temperature, you usually compensate for this change by trimming, or changing the value of, one of the resistors. However, if this variation of leakage current with temperature differs from the variation in divider current due to changes in the resistor values with temperature, the result is a change in V_{OUT} with temperature. This V_{OUT} change is the temperature coefficient. This analogy simplifies the complex mechanism inside a reference circuit, but it conveys the idea

of a device temperature coefficient.

Temperature hysteresis is the change in output voltage with a cycle of temperature variation. To measure the hysteresis, you take a reference operating in a typical application—for example, one that's rated for the extended-operating-temperature range of -40 to $+85^{\circ}\text{C}$ —and record the output voltage at room temperature (25°C). Cool the reference to -40°C and then heat it to 25°C . Again measure and record the output voltage. The difference in these measurements, if any, is the temperature hysteresis.

Conversely, you can measure the temperature at 25°C , heat the device to its maximum temperature of 85°C , cool it back to 25°C , and then measure again. Any difference in these two room-temperature measurements also represents the temperature hysteresis. The deviation can be positive or negative. After many temperature cycles, you might think that the reference output voltage is far off. Because temperature hysteresis is both pos-

POPULAR VOLTAGE-REFERENCE TYPES

The most common type of two-terminal-shunt reference is a zener reference. A zener reference is based on the zener principle, in which the current in a reverse-biased diode begins to flow at a certain voltage threshold and then increases dramatically with an increase in voltage. A resistor in series with the diode establishes a constant current, allowing the zener to achieve a stable reference voltage. The zener reference behaves like a typical shunt, or two-terminal, reference. You can also use this type of reference as voltage clamp.

Three-terminal-series regulators include buried-zener and bandgap types. Achieving a compromise between cost, outstanding accuracy, and low-noise performance, the bandgap reference has become one of the most popular voltage references available. This type of reference compensates the effect of temperature by subtracting the negative-temperature-coeffi-

cient voltage of a forward-biased base-emitter junction from a positive-temperature-coefficient

proportional-to-absolute-temperature (PTAT) voltage. Measuring and amplifying the voltage

difference between two forward-biased diode junctions generates the PTAT voltage.

TABLE A—ZENER-REFERENCE CHARACTERISTICS

Pros	Cons
External bias resistor and load capacitors filter power-supply noise	I_0 varies with changes in power-supply voltage
Low power-supply voltages	High power dissipation
Two terminals only	Requires a careful choice of bias resistor, based on the supply and load requirements
Smaller package size	External bias resistor requires additional board space
Stable over a wide range of C_{LOAD}	Requires accurate supply voltage to improve line regulation
Can perform as a voltage clamp	Low efficiency
Can reference to either supply rail	Low initial accuracy, depending on design
Low cost	Poor temperature stability, depending on design

TABLE B—BURIED-ZENER-REFERENCE CHARACTERISTICS

Pros	Cons
Eliminates surface noise	Requires supply voltages much greater than 5V
Lower temperature drift than zener and bandgap types	High power consumption
Excellent long-term stability	Expensive design
High accuracy	

TABLE C—BANDGAP-REFERENCE CHARACTERISTICS

Pros	Cons
Lower power consumption	Moderate noise characterization
Accuracy is generally sufficient and trimming can improve it	Limited temperature drift
Guaranteed operation down to 1V supply voltage, ideal for portable applications	Larger package

itive and negative, however, the deviations resulting from a series of temperature cycles tend to cancel each other out, producing a final average output voltage close to the nominal value.

Line regulation—a measure of the change in output voltage due to a change in input voltage—is important if the input voltage changes while the reference is operating. Typical units are parts per million per volt and percentage per volt. Line regulation is a dc parameter, and manufacturers typically specify line regulation at dc. Line regulation measures the change in output voltage for two or more dc input voltages and has little meaning if the input voltage varies rapidly, as for a voltage transient. In general, line regulation deteriorates inversely with the rate at which the line voltage changes.

For applications likely to have line transients, reference-input capacitors can minimize the resulting variations.

Load regulation is a measure of the

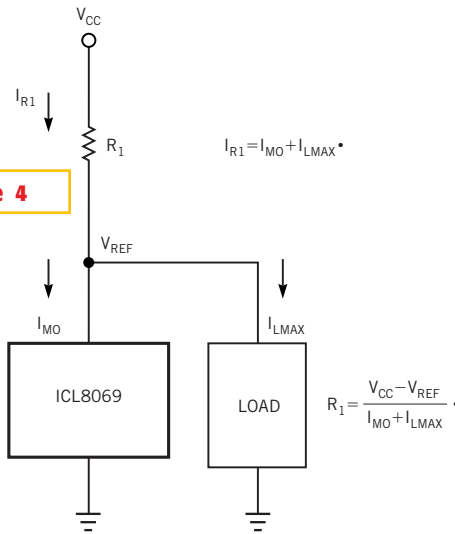

Figure 4

Current flow is the key to analyzing the operation of a shunt reference.

change in output voltage due to a change in the reference load current. This parameter is important if the load current changes while the reference is operating.

Again, load regulation is a dc parameter and manufacturers typically specify it at dc. Load regulation measures the change in output voltage for two or more dc load currents and has little meaning if the load current varies rapidly. In general, load regulation deteriorates inversely with the rate at which the load current changes. Output capacitors can stabilize the output voltage in applications subject to load-current transients. Typical units of measure are parts per million per milliamp, percent per milliamp, and percent of change from no load to full load.

Long-term drift, or stability, is important if the reference must remain accurate for days, weeks, or years of continuous operation. Long-term drift simply measures the variation in output voltage over a period of time at some specified condition of steady-state operation. Long-term drift is a measure of the maximum and minimum output-voltage deviations over an extended time, rather than a measure of de-

variation between “time A” and “time B.” All other conditions, such as temperature, input voltage, and load current, must be constant if this measurement is to accurately reflect drift in the reference. Typical units are parts per million per 1000 hours.

Supply current is self-explanatory but still deserves comment. The data sheets of most series references specify “no-load current” and often use this term interchangeably with “quiescent current.” Because no-load current designates the actual current that an unloaded reference draws, the no-load-current specification omits the current that a loaded reference draws. Typically, data sheets of shunt references do not specify no-load current. Instead, the data sheets of shunt references often list a minimum operating current. This parameter specifies the minimum current the reference must draw to maintain regulation. Note that a shunt reference must draw at least the minimum operating current under full-load conditions. Its series resistor, R_s , must therefore accommodate the maximum load

current plus the minimum operating current (Figure 4). In some applications, the minimum operating current, which some data sheets call regulation current, is negligible because this current is so much smaller than the load current.

Manufacturers often specify *ground current* for a series reference. Ground current measures the operating current at a given load. A series reference is in series with the load, so a measure of current flowing into the reference input yields the sum of load current and operating current.

Dropout voltage, V_{DO} , important in battery-operated equipment, applies only to the series reference. V_{DO} is the minimum difference between input and output voltage that allows the reference to maintain its specified accuracy. ($V_{OUT} + V_{DO}$ = minimum input voltage.) Battery voltage declines as the battery discharges, and, to maximize useful life in the battery, the reference must maintain an accurate output voltage while powered by the lowest possible battery voltage. Thus, a lower dropout voltage al-

lows continued operation at a lower battery voltage.

Load capacitance—the ability of a reference to drive capacitive loads—can be important. Because typical references incorporate feedback control, the zero that a capacitive load introduces can compromise stability. The zero can produce a large phase shift in the control loop that creates positive feedback at a particular frequency. Carefully read the data sheet for information on the allowable range of load capacitance. Some manufacturers refer to this limitation only in the text of the data sheet and not in the parameter tables. □

AUTHOR'S BIOGRAPHY

Roger Kenyon is a manager in the customer-applications division at Maxim Integrated Products (Sunnyvale, CA), where he was worked for four years. He manages staff members in new-product release and technical customer support and has developed analog and mixed-signal ICs. He has a BSEE from Arizona State University (Tempe, AZ).