

Piezoelectric Sound Components

PIEZOELECTRIC SOUND COMPONENTS

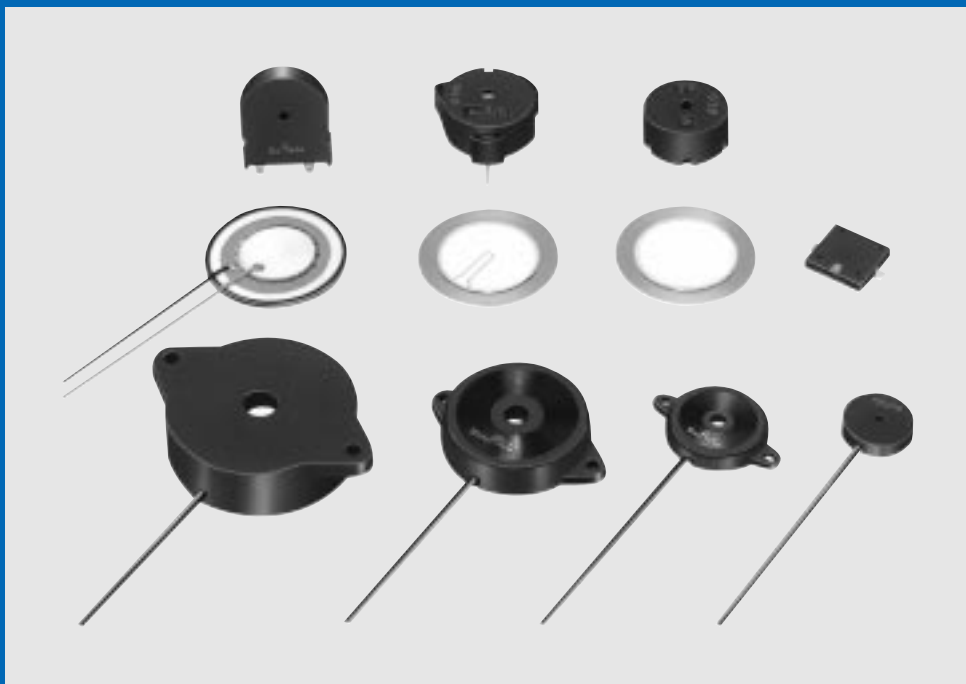

Murata
Manufacturing Co., Ltd.

Cat.No.P37E-16

CONTENTS

PIEZORINGER®, CERAMITONE® and "PIEZORINGER" in this catalog are the trademarks of Murata Manufacturing Co., Ltd.

Part Numbering	_____	2
Application Matrix	_____	4
1 Piezoelectric Diaphragms	_____	5
External-Drives Type	_____	5
Self-Drives Type	_____	6
● Piezoelectric Diaphragms Notice	_____	7
2 Piezoelectric Sounders External-Drives Pin Type	_____	8
3 Piezoelectric Sounders External-Drives Pin Type Taping	_____	14
4 Piezoelectric Sounders External-Drives Lead Wire Type	_____	16
5 Piezoelectric Sounders External-Drives SMD Type	_____	18
Piezoelectric Sounders (External-Drives) Notice	_____	19
6 Piezoelectric Ringers (PIEZORINGER®)	_____	20
Pin Type	_____	20
Lead Wire Type	_____	21
● Piezoelectric Ringers (PIEZORINGER®) Notice	_____	23
7 Piezoelectric Sounders Self-Drives Pin Type	_____	24
● Piezoelectric Sounders (Self-Drives) Notice	_____	25
8 Piezoelectric Buzzers	_____	26
Pin Type	_____	27
Lead Wire Type	_____	27
● Piezoelectric Buzzers Notice	_____	28
9 Piezoelectric Speakers (CERAMITONE®)	_____	29
● Piezoelectric Speakers (CERAMITONE®) Notice	_____	31
Package	_____	32

● **Part Numbering** (The structure of the "Global Part Numbers" that have been adopted since June 2001 and the meaning of each code are described herein.)
 (If you have any questions about details, inquire at your usual Murata sales office or distributor.)

Piezoelectric Speakers (CERAMITONE®)

(Global Part Number)

VS	B	35	E	W	-07	01	B
①	②	③	④	⑤	⑥	⑦	⑧

① Product ID

Product ID	
VS	Piezoelectric Speakers

② Product

Code	Product
B	Piezoelectric Diaphragms

③ Outer Dimensions

Code	Outer Dimensions
35	ø35mm
50	ø50mm

④ Drive

Code	Drive
E	External Drive

⑤ Outer Electrode Style

Code	Outer Electrode Style
W	Lead Wire Type

⑥ Resonant Frequency Type

Code	Resonant Frequency
-03	1st Resonant Frequency : 300Hz
-07	1st Resonant Frequency : 700Hz

⑦ Individual Specification Code

Code	Individual Specification Code
01	Characteristics, Style, others

⑧ Numbers of Ceramic

Code	Numbers of Ceramic
B	Two Elements (The code is omitted when element is one.)

Piezoelectric Diaphragms

(Global Part Number)

7	N	B	-31R2	DM	-1R5		A	10
①	②	③	④	⑤	⑥	⑦	⑧	⑨

① Product ID(1)

Product ID(1)	Ceramic Material
7	A2

② Product(2)

Product ID(2)	Metal Plate Material
B	Brass
N	Nickel Alloy
M	Ni Plated Iron
S	SUS

③ Product

Code	Product
B	Piezoelectric Diaphragms

④ Metal Plate Diameter

Code	Metal Plate Diameter
-31R2	A hyphen (-) plus four-digit alphanumerics express metal plate outer dimensions. A decimal point is expressed by the capital letter "R".

If there is no decimal point, the decimal point code is omitted.

⑤ Form of Piezoelectric Style

Code	Form of Piezoelectric Style
DM	Two digits express shape of ceramics.

For an Ag electrode, this digit remains blank, the corresponding code is omitted.

⑥ Resonant Frequency Type

Code	Resonant Frequency (kHz)
-1R5	A hyphen (-) and three-digit alphanumerics express resonant frequency. A decimal point is expressed by the capital letter "R".

If there is no decimal point, the decimal point is omitted.

⑦ With Feedback Electrode

Code	With Feedback Electrode
C	With Feedback Electrode
—	without Feedback Electrode

⑧ Product Specification

Code	Product Specification
A	With lead
—	No lead (omitted)

⑨ Individual Specification Code

Code	Individual Specification Code
10	These digits express a lead length, lead number, and presence/absence of a connector.

If the product has no individual specification, the corresponding code is omitted.

Piezoelectric Sounders/Piezoelectric Buzzers/Piezoelectric Ringers(PIEZORINGER®)

(Global Part Number) **PK** **M** **13** **E** **P** **Y** **-40** **00** **P** **-A0**
 ① ② ③ ④ ⑤ ⑥ ⑦ ⑧ ⑨ ⑩

① Product ID

Product ID	
PK	Piezoelectric Sound Components

② Product

Code	Product
M	Sounder, Ringer
B	Buzzer

③ Outer Dimensions

Expressed by two figures in mm.

Ex.)

Code	Outer Dimensions
13	ø12.6mm

④ Drive

Code	Drive
E	External-Drive
S	Self-Drive

⑤ Outer Electrode Style

Code	Outer Electrode Style
P	Pin Type
W	Lead Wire Type

⑥ Structure

Code	Structure
T	Standing Type
P	Flat Type Auto-assemble
Y	Flat Type/Available for Taping
C	Flat Type/Semi-auto-assemble

⑦ Oscillating Frequency Type

Code	Oscillating Frequency Type
-40	A hyphen (-) plus two-digit figures express Oscillating Frequency type.

If there is no decimal point, the decimal point is omitted.

⑧ Individual Specification Code

Code	Individual Specification Code
00	Two digits express specific specification in characteristics.

⑨ Special Quality Guarantee

Code	Special Quality Guarantee
P	Post Plated Terminal
-	Omitted

⑩ Packaging

Code	Packaging
-B0	Bulk
-A0	Radial Taping
-M0	Magazine

Radial taping or magazine are not available for all types. Please contact us.

Application Matrix

		Application	Tele- phone	Watch	Clock	Medical Equip- ment	Gas Alarm	Camera	Toy	Bar Code Scanner	Type- Writer	Printer	Note- PC PDA	DVD- Player	Micro- Wave Oven	Air Condi- tioner	Fan Heater	
		Part Number																
Piezoelectric Diaphragm	External drive type	7BB-12-9		●	●	●		●	●				●					
		7BB-15-6			●	●		●	●				●					
		7BB-20-3	●	●	●	●			●	●								
		7BB-20-4	●	●	●	●			●	●	●							
		7BB-20-6			●	●			●	●				●				
		7BB-20-6A0			●	●				●				●				
		7BB-27-4	●		●	●				●	●							
		7BB-27-4A0	●		●	●				●	●							
		7BB-35-3	●		●					●	●							
		7BB-35-3A0	●		●					●	●							
		7BB-41-2	●															
		7BB-41-2A0	●															
		7BB-50M-1	●															
	7SB-20-7		●	●	●				●				●					
	Self drive type	7BB-20-6C	●						●	●								
		7BB-20-6CA0	●						●	●								
		7BB-27-3C	●					●		●								
		7BB-27-4C	●					●		●	●							
		7BB-27-4CA0	●					●		●	●							
		7BB-35-3C	●					●			●							
7BB-35-3CA0		●					●			●								
7BB-41-20		●																
7BB-41-2CA0		●																
7NB-27-2C		●																
7NB-27-3C	●					●												
7NB-27-4C	●					●												
7SB-34R7-3C						●												
Piezoelectric Sounder	External drive type	PKM13EPY-4000-A0	●		●	●		●	●	●	●	●	●	●		●	●	
		PKM13EPY-4002-B0	●		●	●			●	●	●	●	●	●	●	●	●	●
		PKM17EPP-2002-B0	●		●	●				●	●	●	●	●	●	●	●	●
		PKM17EPP-4001-B0	●		●	●				●	●	●	●	●	●	●	●	●
		PKM17EPT-4001-B0								●		●	●	●	●	●	●	●
		PKM17EW-2001	●		●	●			●	●	●	●	●	●	●		●	
		PKM22EP-2001								●		●	●	●	●	●	●	●
		PKM22EPP-2001-B0	●		●	●				●		●	●	●	●	●	●	●
		PKM22EPP-4001-B0	●		●	●				●		●	●	●	●	●	●	●
		PKM22EPP-4005-B0	●		●	●				●		●	●	●	●	●	●	●
		PKM22EPP-4007-B0	●		●	●				●		●	●	●	●	●	●	●
		PKM22EPT-2001-B0								●		●	●	●	●	●	●	●
		PKM22EPT-4001-B0								●		●	●	●	●	●	●	●
		PKM17EW-4000	●		●	●				●	●	●	●	●	●		●	
	PKMC16E-4000-T0	●			●				●	●	●	●	●			●		
	Self drive type	PKM24SP-3805	●					●		●						●	●	●
		PKM30SPT-2001-B0								●		●	●			●		
PKM30SPT-2501-B0									●		●	●						
Piezoelectric Buzzer	PKB24SPC-3601-B0	●			●				●		●	●	●	●		●	●	
	PKB24SW-3301	●		●					●		●	●	●		●	●	●	
	PKB30SPC-2001-B0	●					●		●		●	●	●		●	●	●	
	PKB30SPC-3001-B0	●					●		●		●	●	●		●	●	●	
Piezoelectric Ringer	PKM33EP-1201C	●																
	PKM34EW-1101C	●																
	PKM34EW-1201C	●																
	PKM44EP-0901	●																
Piezoelectric Speaker	PKM44EW-1001C	●																
	VSB35EW-0701B	●							●									
	VSB50EW-0301B	●							●									

Fire Alarm, Burglar Alarm, Laundry Machine, Bath, Interphone, Chime, Pager, Back Buzzer, ME Instruments, Measuring Instruments, Vending Machine, Calculator, Automobile, Communication Radio, Hemodynamometer, Thermometer, Running meter, Facsimile, Audio timer, Automatic Controlling Devices.

Piezoelectric Sound Components

1

Piezoelectric Diaphragms

External-Drives Type

■ Features

1. Low power consumption.
2. No contacts therefore, no noise and highly reliable.

■ Applications

- Telephone ringers.
- Various office equipment such as PPCs, printers and keyboards.
- Various home appliances such as microwave ovens.
- Confirmation sound of various audio equipment.

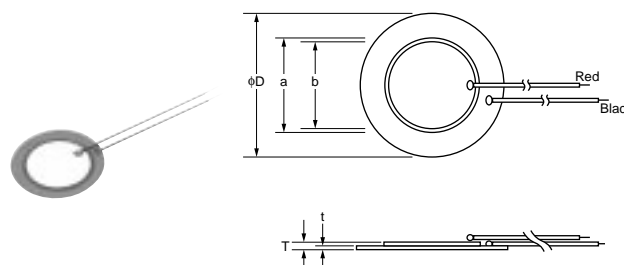

Part Number	Resonant Frequency (kHz)	Resonant Impedance (ohm)	Capacitance (nF)	Plate Size dia D (mm) (dia)	Element Size a (mm) (dia)	Electrode Size b (mm) (dia)	Thickness T (mm)	Plate Thickness t (mm)	Plate Material
7BB-12-9	9.0 ±1.0kHz	1000 max.	8 ±30% [1kHz]	12.0	9.0	8.0	0.22	0.10	Brass
7BB-15-6	6.0 ±1.0kHz	350 max.	10 ±30% [1kHz]	15.0	10.0	9.0	0.22	0.10	Brass
7BB-20-3	3.6 ±0.6kHz	500 max.	20 ±30% [1kHz]	20.0	14.0	12.8	0.22	0.10	Brass
7BB-20-6	6.3 ±0.6kHz	350 max.	10 ±30% [1kHz]	20.0	14.0	12.8	0.42	0.20	Brass
7BB-20-6A0	6.3 ±0.6kHz	1000 max.	10 ±30% [1kHz]	20.0	14.0	12.8	0.42	0.20	Brass (with Lead Wire)
7BB-27-4	4.6 ±0.5kHz	200 max.	20 ±30% [1kHz]	27.0	19.7	18.2	0.54	0.30	Brass
7BB-27-4A0	4.6 ±0.5kHz	300 max.	20 ±30% [1kHz]	27.0	19.7	18.2	0.54	0.30	Brass (with Lead Wire)
7BB-35-3	2.8 ±0.5kHz	200 max.	30 ±30% [1kHz]	35.0	25.0	23.0	0.53	0.30	Brass
7BB-35-3A0	2.8 ±0.5kHz	200 max.	30 ±30% [1kHz]	35.0	25.0	23.0	0.53	0.30	Brass (with Lead Wire)
7BB-41-2	2.2 ±0.3kHz	250 max.	30 ±30% [1kHz]	41.0	25.0	23.0	0.63	0.40	Brass
7BB-41-2A0	2.2 ±0.3kHz	300 max.	30 ±30% [1kHz]	41.0	25.0	23.0	0.63	0.40	Brass (with Lead Wire)
7BB-50M-1	1.0 ±0.3kHz	1200 max.	28 ±30% [120Hz]	50.0	25.0	23.0	0.44	0.20	Nickel-Plated Brass
7SB-20-7	7.2 ±0.8kHz	350 max.	10 ±30% [1kHz]	20.0	14.0	12.8	0.42	0.20	Stainless

Self-Drives Type

■ Features

1. Low power consumption.
2. No contacts therefore, no noise and highly reliable.

■ Applications

- Telephone ringers.
- Various office equipment such as PPCs, printers and keyboards.
- Various home appliances such as microwave ovens.
- Confirmation sound of various audio equipment.

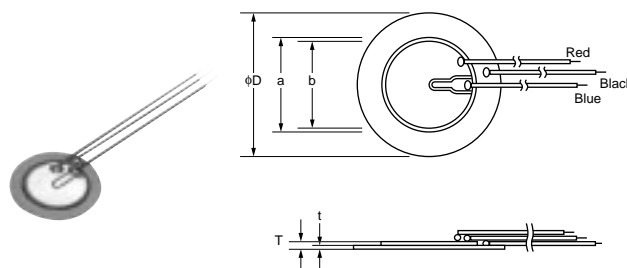

Part Number	Resonant Frequency (kHz)	Resonant Impedance (ohm)	Capacitance (nF)	Plate Size dia D (mm) (dia)	Element Size a (mm) (dia)	Electrode Size b (mm) (dia)	Thickness T (mm)	Plate Thickness t (mm)	Plate Material
7BB-20-6C	6.3 ±0.6kHz	500 max.	8.5 ±30% [1kHz]	20.0	14.0	12.8	0.42	0.20	Brass
7BB-20-6CA0	6.3 ±0.6kHz	800 max.	8.5 ±30% [1kHz]	20.0	14.0	12.8	0.42	0.20	Brass (with Lead Wire)
7BB-27-3C	3.0 ±0.5kHz	300 max.	35 ±30% [1kHz]	27.0	19.7	18.2	0.27	0.15	Brass
7BB-27-4C	4.6 ±0.5kHz	200 max.	18 ±30% [1kHz]	27.0	19.7	18.2	0.54	0.30	Brass
7BB-27-4CA0	4.6 ±0.5kHz	350 max.	18 ±30% [1kHz]	27.0	19.7	18.2	0.54	0.30	Brass (with Lead Wire)
7BB-35-3C	2.8 ±0.5kHz	200 max.	26 ±30% [1kHz]	35.0	25.0	23.0	0.53	0.30	Brass
7BB-35-3CA0	2.8 ±0.5kHz	200 max.	26 ±30% [1kHz]	35.0	25.0	23.0	0.53	0.30	Brass (with Lead Wire)
7BB-41-2C	2.2 ±0.3kHz	250 max.	24 ±30% [1kHz]	41.0	25.0	23.0	0.63	0.40	Brass
7BB-41-2CA0	2.2 ±0.3kHz	350 max.	24 ±30% [1kHz]	41.0	25.0	23.0	0.63	0.40	Brass (with Lead Wire)
7NB-27-2C	2.2 ±0.5kHz	300 max.	37 ±30% [120Hz]	27.0	19.7	18.2	0.22	0.10	Iron Nickel Alloy
7NB-27-3C	3.0 ±0.5kHz	300 max.	24 ±30% [1kHz]	27.0	19.7	18.2	0.32	0.15	Iron Nickel Alloy
7NB-27-4C	3.8 ±0.5kHz	300 max.	19 ±30% [1kHz]	27.0	19.7	18.2	0.42	0.20	Iron Nickel Alloy
7SB-34R7-3C	3.1 ±0.3kHz	150 max.	24 ±30% [1kHz]	34.7	25.0	23.4	0.50	0.25	Stainless

■ Node Diameter

Part Number	Node Diameter (mm)
7BB-20-6C	φ13.5
7BB-27-4C	φ17.5
7BB-35-3C	φ22.5
7BB-41-2C	φ26.5

- Sound diaphragm without feedback electrode also have the same node diameters.

Piezoelectric Diaphragms Notice

1

■ Notice (Soldering and Mounting)

1. Applying load on the center area of the diaphragm may cause clack in the ceramic element. When the diaphragm is supported by edge, the load should be only applied around edge.
2. Please consult with Murata or Murata representative, in case of soldering on the component.

■ Notice (Handling)

1. Please do not touch the component with bare hand because electrode may be corroded.
2. The component may be damaged if mechanical stress over this specification is applied.
3. Please pay attention to protect operating circuit from surge voltage provided by something of force such as falling, shock and temperature changing.
4. If DC voltage is applied to the component, silver migration may occur. Please pay full attention not to subject the component to DC voltage for long periods.
5. The resistor should be used as shown in Fig. A.
A suitable resistance value should be chosen, preferably $1\text{k}\Omega$ to $2\text{k}\Omega$. Instead of this measure, a diode may also be applied as shown in Fig. B.

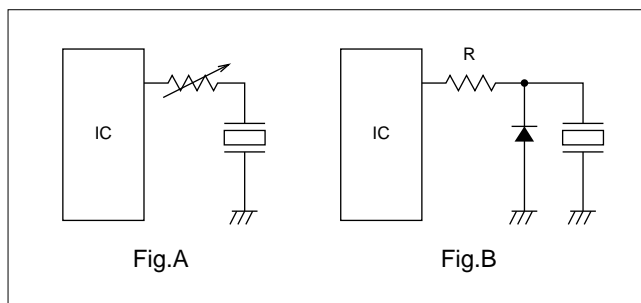

6. Please pay enough attention not to pull lead wire too much because wire may be broken or soldering point may come off.

Piezoelectric Sound Components



Piezoelectric Sounders External-Drives Pin Type

2

Now, microcomputers are widely used for microwave ovens, air conditioners, cars, toys, timers, and other alarm equipment. Externally driven piezoelectric sounders are used in digital watches, electronic calculators, telephones and other equipment. They are driven by a signal (ex, 2048Hz or 4096Hz) from an LSI and provide melodious sound.

■ Features

1. Low power consumption.
2. No contacts therefore, no noise and highly reliable.

■ Applications

- Telephone ringers.
- Various office equipment such as PPCs, printers and keyboards.
- Various home appliances such as microwave ovens.
- Confirmation sound of various audio equipment.

PKM13EPY-4002-B0

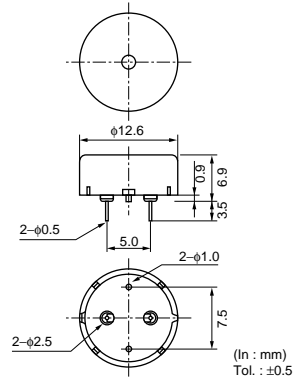

PKM17EPP-2002-B0

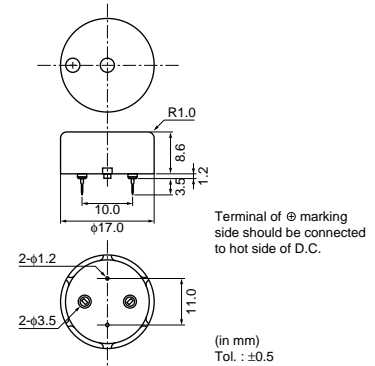

PKM17EPP-4001-B0

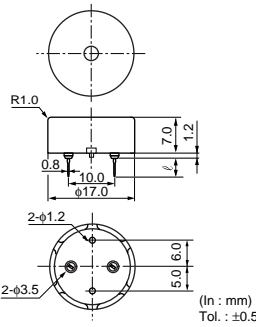

Part Number	ℓ
PKM17EPP-4001-B0	6.5
PKM17EPP-4002-B0	3.5

PKM17EPT-4001-B0

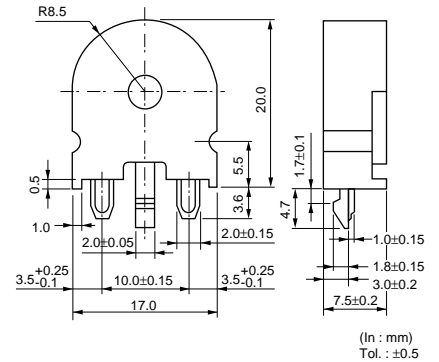

PKM22EP-2001

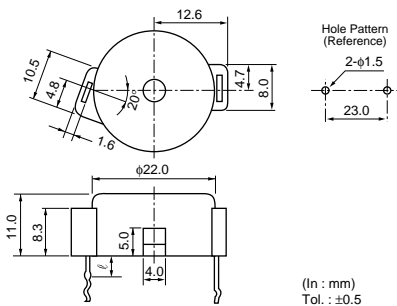

Part Number	ℓ
PKM22EP-2001	4.0
PKM22EP-2002	8.0
PKM22EP-2003	12.0

PKM22EPP-2001-B0

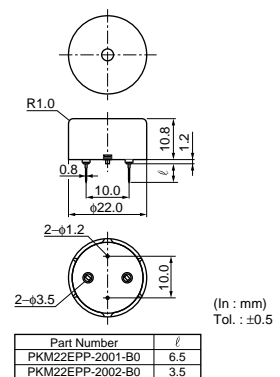

Part Number	ℓ
PKM22EPP-2001-B0	6.5
PKM22EPP-2002-B0	3.5

Continued on the following page. ↗

Continued from the preceding page.



PKM22EPP-4001-B0

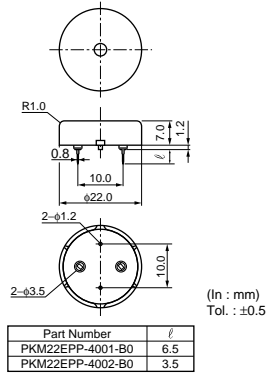

PKM22EPP-4005-B0

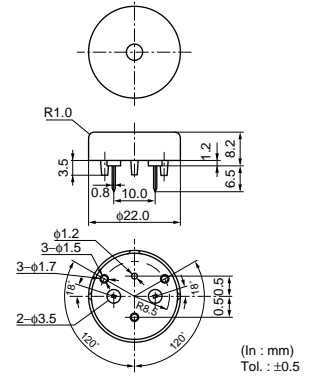

PKM22EPP-4007-B0

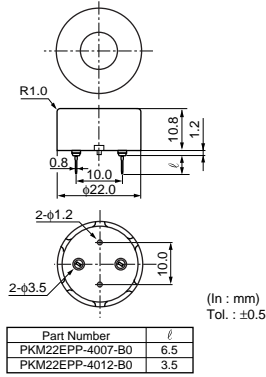

PKM22EPT-2001-B0

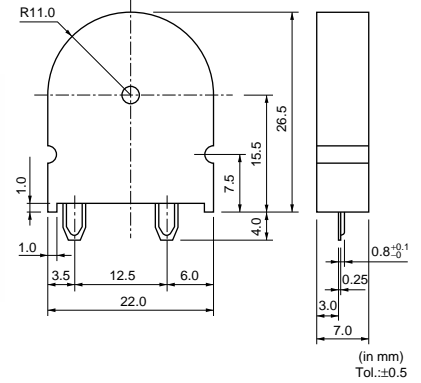

PKM22EPT-4001-B0

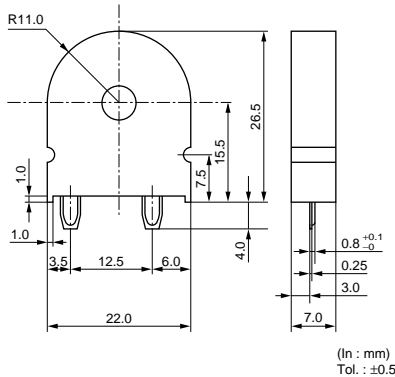

■ Circuit

The following are examples of externally driven circuits.
(1) Unstable multi-vibrator using Tr.
(2) Circuits using inverters or NAND gates.

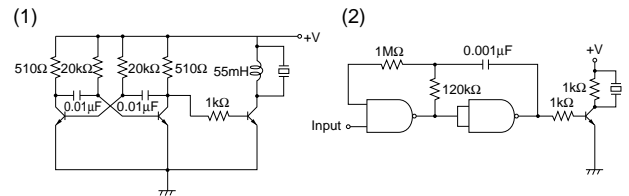

Part Number	Sound Pressure Level (dB)	Sound Pressure Level(Ref. only) (dB)	Operating Voltage Range (Vp-p)	Capacitance (nF)	Operating Temp. Renge	Storage Temp. Renge
PKM13EPY-4002-B0	70 min. [3Vp-p,4kHz,square wave,10cm]	70 min. [1Vrms,4kHz,sine wave,10cm]	25 max.	5.5 ±30% [1kHz]	-20 to +70°C	-30 to +80°C
PKM17EPP-2002-B0	70 min. [3Vo-p,2kHz,square wave,10cm]	70 min. [1Vrms,2kHz,sine wave,10cm]	25 Vo-p max. [with polarity]	34 ±30% [120Hz]	-20 to +70°C	-30 to +80°C
PKM17EPP-4001-B0	72 min. [3Vp-p,4kHz,square wave,10cm]	72 min. [1Vrms,4kHz,sine wave,10cm]	25 max.	7 ±30% [1kHz]	-20 to +70°C	-30 to +80°C
PKM17EPT-4001-B0	75 min. [3Vp-p,4kHz,square wave,10cm]	75 min. [1Vrms,4kHz,sine wave,10cm]	25 max.	9.5 ±30% [1kHz]	-20 to +70°C	-30 to +80°C
PKM22EP-2001	75 min. [3Vp-p,2kHz,square wave,10cm]	75 min. [1Vrms,2kHz,sine wave,10cm]	25 max.	17 ±30% [120Hz]	-20 to +70°C	-30 to +80°C
PKM22EPP-2001-B0	70 min. [3Vp-p,2kHz,square wave,10cm]	70 min. [1Vrms,2kHz,sine wave,10cm]	25 max.	19 ±30% [120Hz]	-20 to +70°C	-30 to +80°C
PKM22EPP-4001-B0	75 min. [3Vp-p,4kHz,square wave,10cm]	75 min. [1Vrms,4kHz,sine wave,10cm]	25 max.	12 ±30% [1kHz]	-20 to +70°C	-30 to +80°C
PKM22EPP-4005-B0	75 min. [3Vp-p,4kHz,square wave,10cm]	75 min. [1Vrms,4kHz,sine wave,10cm]	25 max.	12 ±30% [1kHz]	-20 to +70°C	-30 to +80°C

Continued on the following page.

Continued from the preceding page.

Part Number	Sound Pressure Level (dB)	Sound Pressure Level(Ref. only) (dB)	Operating Voltage Range (Vp-p)	Capacitance (nF)	Operating Temp. Renge	Storage Temp. Renge
PKM22EPP-4007-B0	85 min. [3Vp-p,4kHz,square wave,10cm]	85 min. [1Vrms,4kHz,sine wave,10cm]	25 max.	12 ±30% [1kHz]	-20 to +70°C	-30 to +80°C
PKM22EPT-2001-B0	70 min. [3Vp-p,2kHz,square wave,10cm]	70 min. [1Vrms,2kHz,sine wave,10cm]	25 max.	19 ±30% [120Hz]	-20 to +70°C	-30 to +80°C
PKM22EPT-4001-B0	85 min. [3Vp-p,4kHz,square wave,10cm]	85 min. [1Vrms,4kHz,sine wave,10cm]	25 max.	10 ±30% [1kHz]	-20 to +70°C	-30 to +80°C

2

■ Freq. Response (Square Wave 3Vp-p, 10cm)

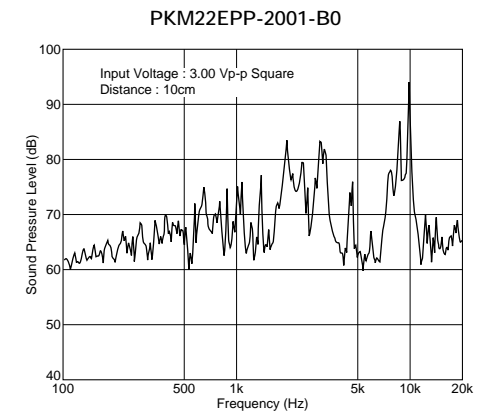
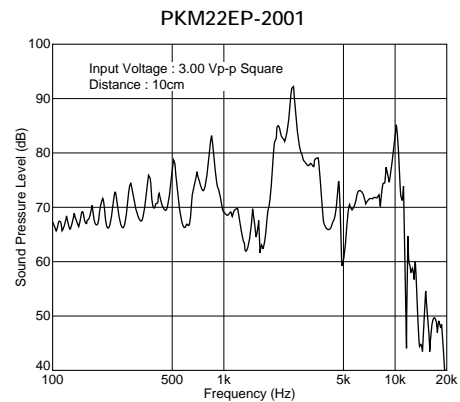
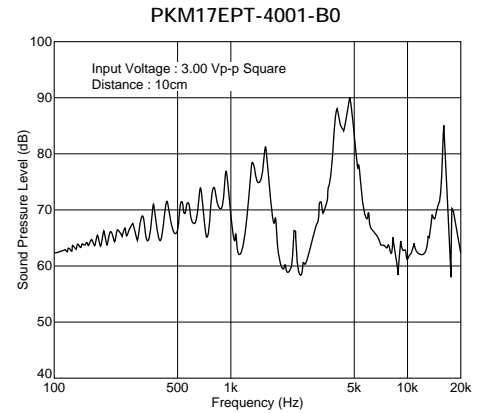
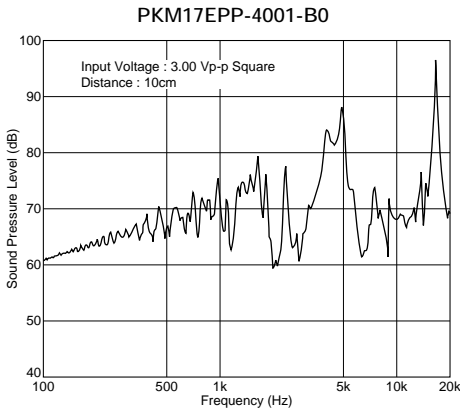
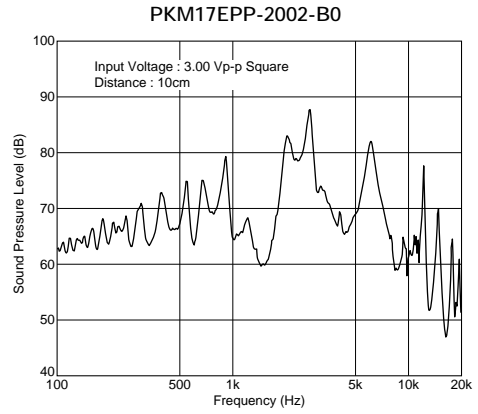
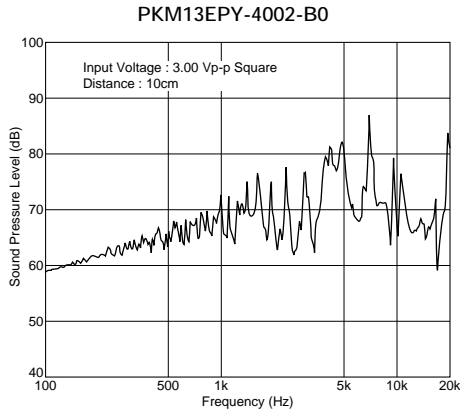

Continued on the following page. ↗

Continued from the preceding page.

■ Freq. Response (Square Wave 3Vp-p, 10cm)

PKM22EPP-4001-B0

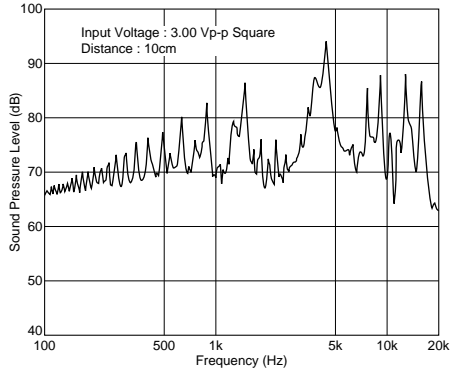

PKM22EPP-4005-B0

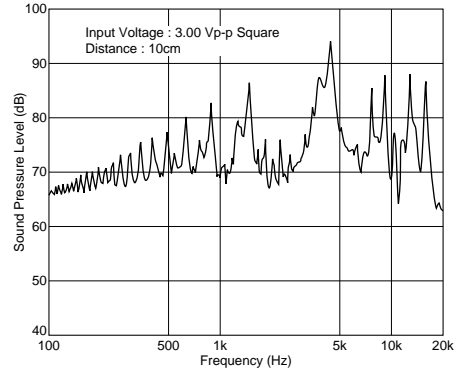

PKM22EPP-4007-B0

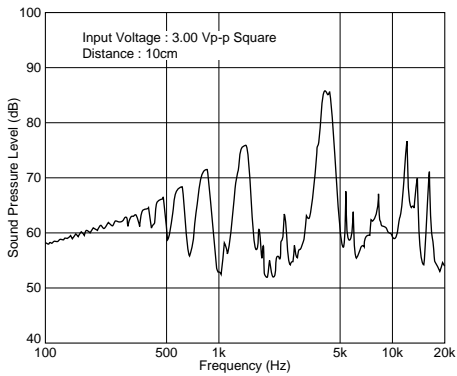

PKM22EPT-2001-B0

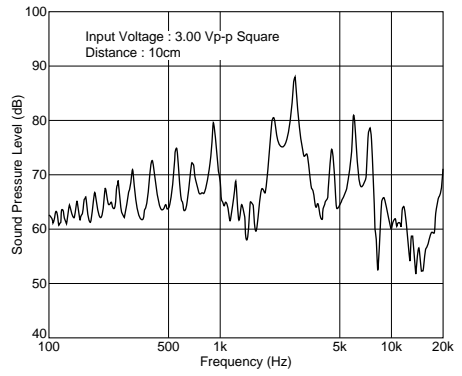

PKM22EPT-4001-B0

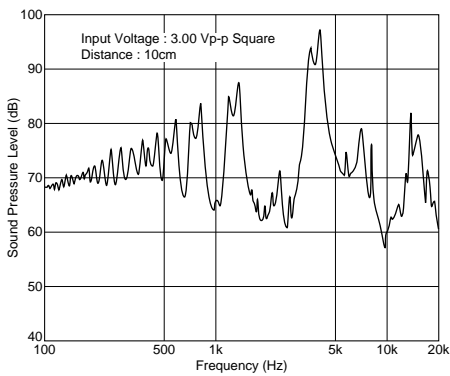

■ Freq. Response (Sine Wave 1Vrms, 10cm)

PKM13EPY-4002-B0

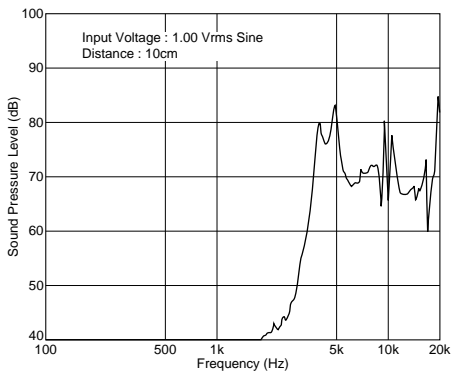

PKM17EPP-2002-B0

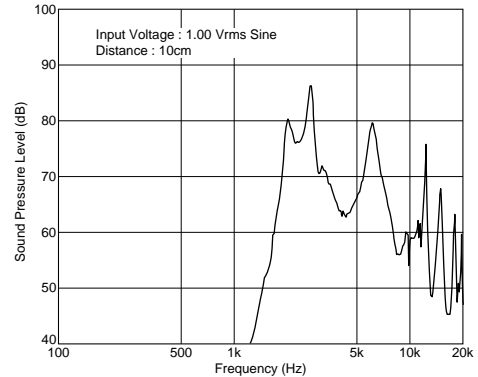

Continued on the following page.

Continued from the preceding page.

Freq. Response (Sine Wave 1Vrms, 10cm)

2

PKM17EPP-4001-B0

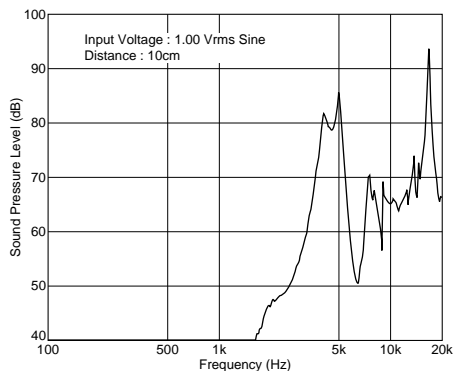

PKM17EPT-4001-B0

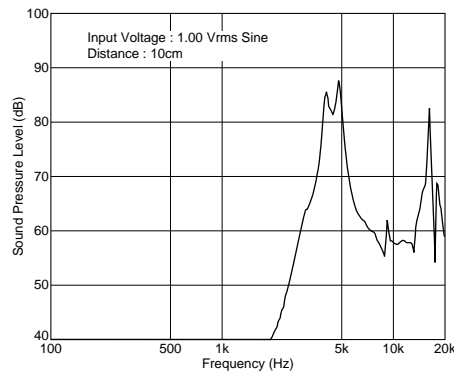

PKM22EP-2001

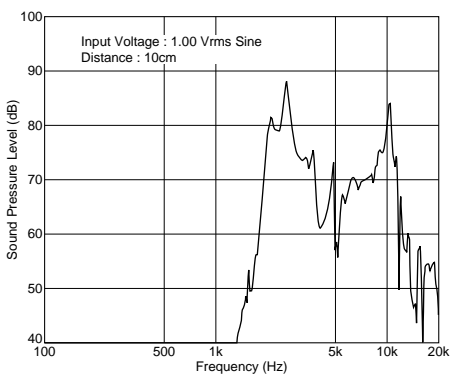

PKM22EPP-2001-B0

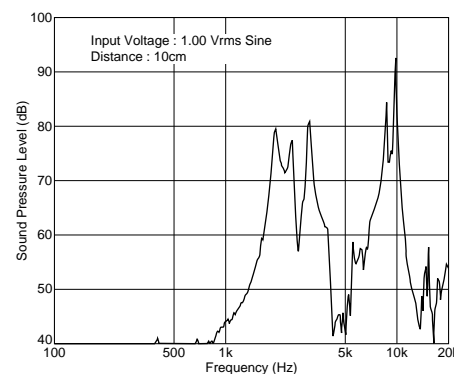

PKM22EPP-4001-B0

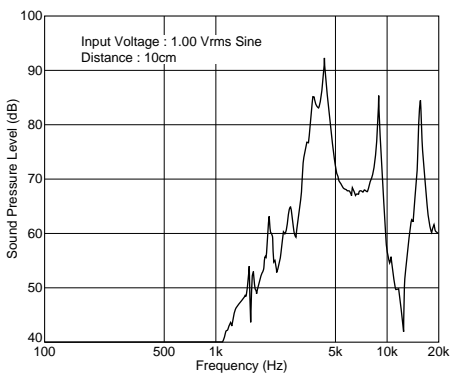

PKM22EPP-4005-B0

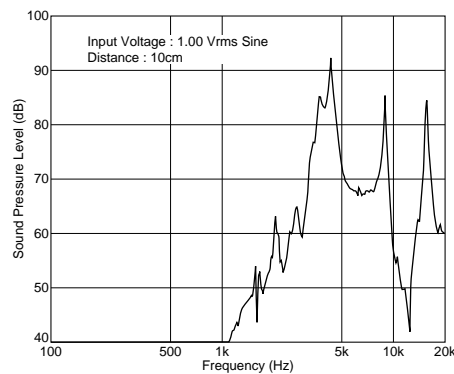

PKM22EPP-4007-B0

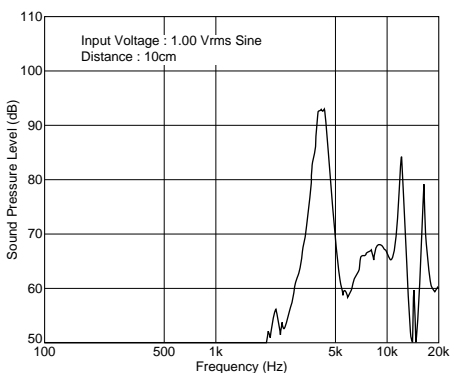

PKM22EPT-2001-B0

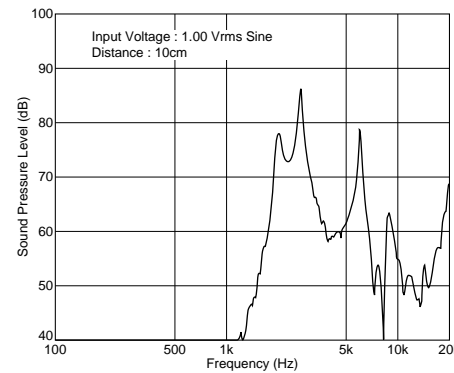

Continued on the following page.

Continued from the preceding page.

■ Freq. Response (Sine Wave 1Vrms, 10cm)

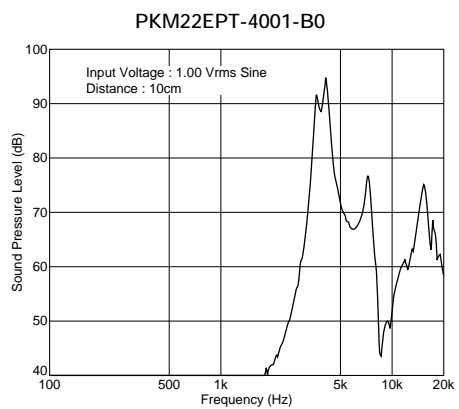

2

Piezoelectric Sound Components



Piezoelectric Sounders External-Drives Pin Type Taping

Taking advantage of extensive automatic insertion designing technology and materials experience, Murata has developed standard taping type piezoelectric sounder.

This Murata technology supports labor and cost saving activities.

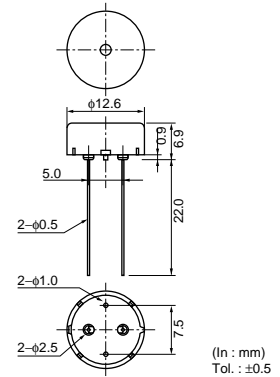
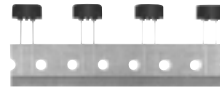

3

■ Features

1. High and stable mountability.
2. Ammo packaging.
3. Minimum quantity (order in sets only) : 500pcs.

Part Number	Sound Pressure Level (dB)	Sound Pressure Level(Ref. only) (dB)	Operating Voltage Range (Vp-p)	Capacitance (nF)	Operating Temp. Renge	Storage Temp. Renge
PKM13EPY-4000-A0	70 min. [3Vp-p,4kHz,square wave,10cm]	70 min. [1Vrms,4kHz,sine wave,10cm]	25 max.	5.5 ±30% [1kHz]	-20 to +70°C	-30 to +80°C

■ Freq. Response (Square Wave 3Vp-p, 10cm)

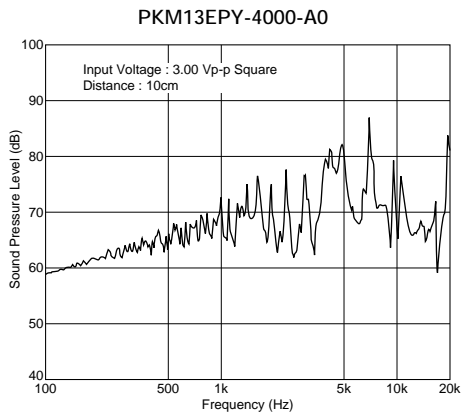

■ Freq. Response (Sine Wave 1Vrms, 10cm)

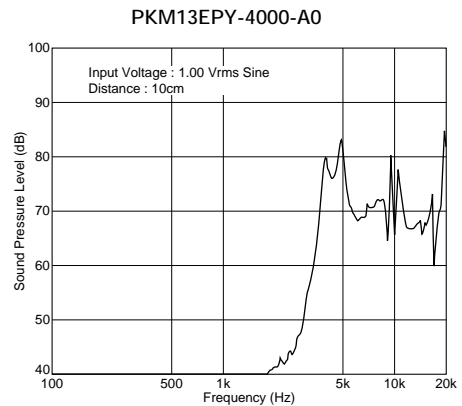

Continued on the following page.

 Continued from the preceding page.

■ Taping Dimension

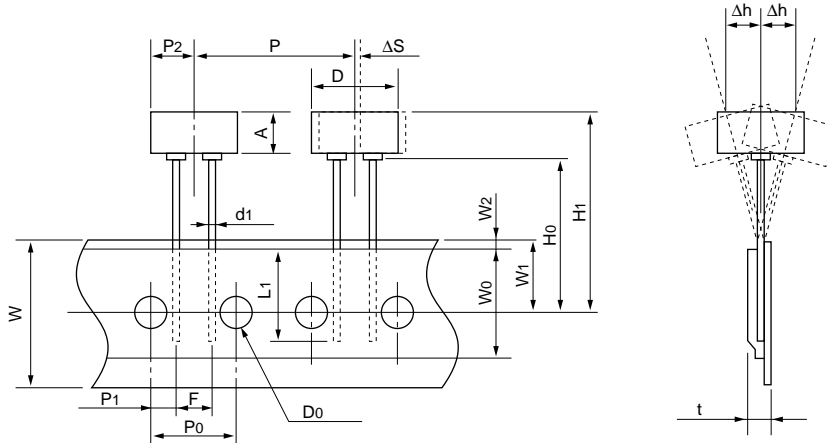

Item	Code	Nominal value	Tol.	Remarks
Width of Diameter	D	$\phi 12.6$	± 0.5	
Height of Component	A	6.9	± 0.5	
Dimensions of Terminal	d1	$\phi 0.5$	± 0.1	
Lead length under The Hold down Tape	L1	8.0 min.	—	
Pitch of Component	P	25.4	± 0.5	
Pitch of Sprocket	P0	12.7	± 0.2	Tolerance for Pitches $10 \times P_0 = 127 \pm 2 \text{mm}$
Length from Hole Center to Lead	P1	3.85	± 0.7	
Length from Hole Center to Component Center	P2	6.35	± 0.7	
Lead Spacing	F	5.0	± 0.5	
Slant to The Forward or Backward	Δh	0	± 1.0	$360^\circ : 1 \text{mm max.}$
Width of Carrier Tape	W	18.0	± 0.5	
Width of Hold down Tape	W0	12.5 min.	—	Hold down tape does not exceed the carrier tape.
Position of Sprocket Hole	W1	9.0	± 0.5	
Gap of Hold Down Tape and Carrier Tape	W2	2.0 max.	—	
Distance Between The Center of Sprocket Hole and Lead Stopper	H0	18.0	± 0.5	
Total Height of Component	H1	26.0 max.	—	
Diameter of Sprocket Hole	D0	$\phi 4.0$	± 0.2	
Total Thickness of Tape	t	0.6	± 0.2	
Body Tilt	ΔS	0	± 1.0	

(in mm)

Piezoelectric Sound Components



Piezoelectric Sounders External-Drives Lead Wire Type

Now, microcomputers are widely used for microwave ovens, air conditioners, cars, toys, timers, and other alarm equipment. Externally driven piezoelectric sounders are used in digital watches, electronic calculators, telephones and other equipment. They are driven by a signal (ex, 2048Hz or 4096Hz) from an LSI and provide melodious sound.

■ Features

1. Low power consumption.
2. No contacts therefore, no noise and highly reliable.

■ Applications

- Telephone ringers.
- Various office equipment such as PPCs, printers and keyboards.
- Various home appliances such as microwave ovens.
- Confirmation sound of various audio equipment.

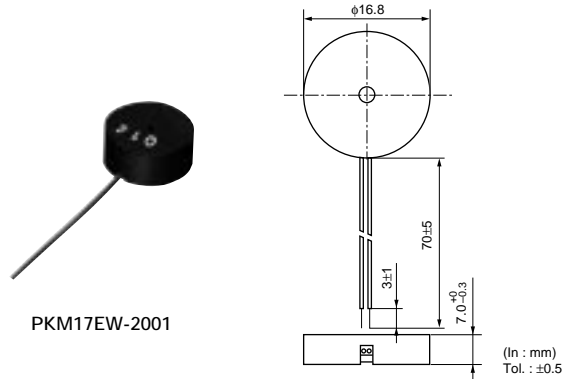

PKM17EW-2001

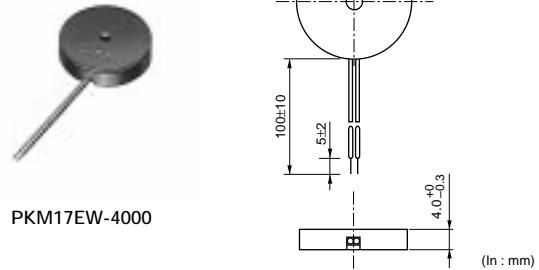

PKM17EW-4000

Part Number	Sound Pressure Level (dB)	Sound Pressure Level(Ref. only) (dB)	Operating Voltage Range (Vp-p)	Capacitance (nF)	Operating Temp. Range	Storage Temp. Range
PKM17EW-2001	72 min. [3Vp-p,2kHz,square wave,10cm]	70 min. [1Vrms,2kHz,sine wave,10cm]	7 max.	40 ±30% [120Hz]	-20 to +70°C	-30 to +80°C
PKM17EW-4000	75 min. [3Vp-p,4kHz,square wave,10cm]	70 min. [1Vrms,4kHz,sine wave,10cm]	25 max.	9.5 ±30% [1kHz]	-20 to +70°C	-30 to +80°C

■ Freq. Response (Square Wave 3Vp-p, 10cm)

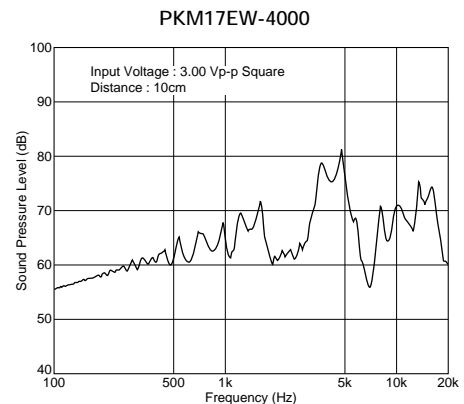
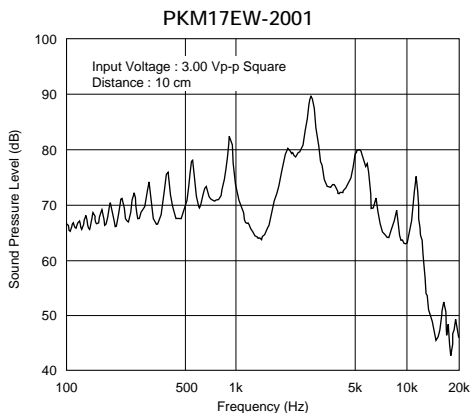

Continued on the following page.

Continued from the preceding page.

■ Freq. Response (Sine Wave 1Vrms, 10cm)

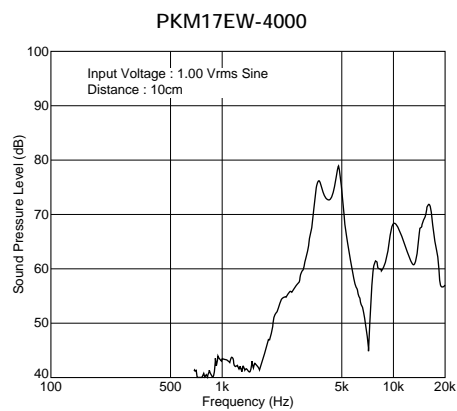
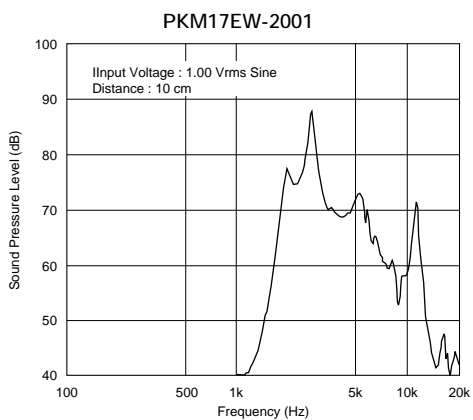

Piezoelectric Sound Components



Piezoelectric Sounders External-Drives SMD Type

Taking advantage of extensive acoustic and mechanical designing technology and high performance ceramics, Murata has developed SMD piezoelectric sounder that suites thin, high-density design of electronic equipment.

■ Features

1. High S.P.L. and clear sound.
2. Reflowable.
3. Tray packaging
4. Minimum quantity (order in sets only) : 80pcs.

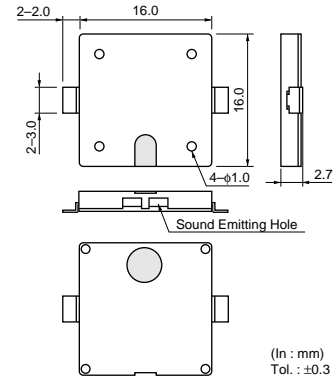

Part Number	Sound Pressure Level (dB)	Operating Voltage Range (Vp-p)	Capacitance (nF)	Operating Temp. Renge	Storage Temp. Renge
PKMC16E-4000-T0	75 min. [3Vp-p,4kHz,square wave,10cm]	25 max.	14 ±30% [1kHz]	-20 to +70°C	-30 to +80°C

5

■ Recommendable Land Pattern Dimensions

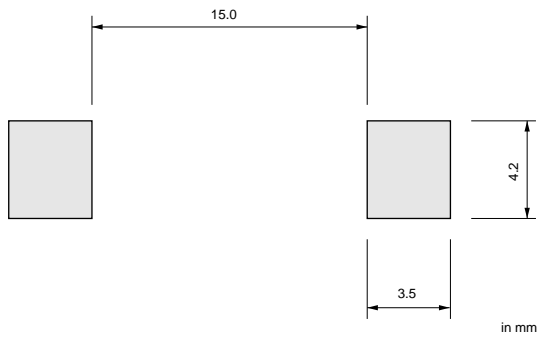

■ Freq. Response (Square Wave 3Vp-p, 10cm)

PKMC16E-4000-T0

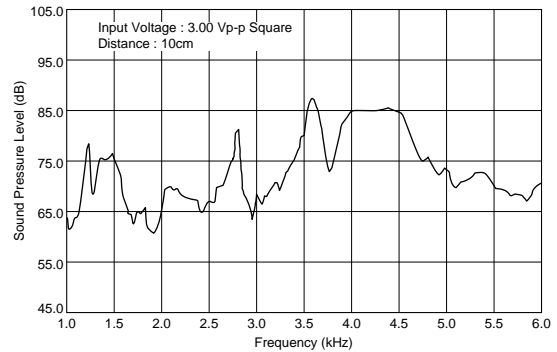

Piezoelectric Sounders (External-Drives) Notice

■ Notice (Soldering and Mounting)

Washing of the component is not acceptable, because it is not sealed.

■ Notice (Handling)

1. The component may be damaged if mechanical stress over this specification is applied.
2. Please pay attention to protect operating circuit from surge voltage provided by something of force such as falling, shock and temperature changing.
3. If DC voltage is applied to the component, silver migration may occur. Please pay full attention not to subject the component to DC voltage for long periods.
4. The resistor should be used as shown in Fig. A.
A suitable resistance value should be chosen, preferably $1k\Omega$ to $2k\Omega$. Instead of this measure, a diode may also be applied as shown in Fig. B.

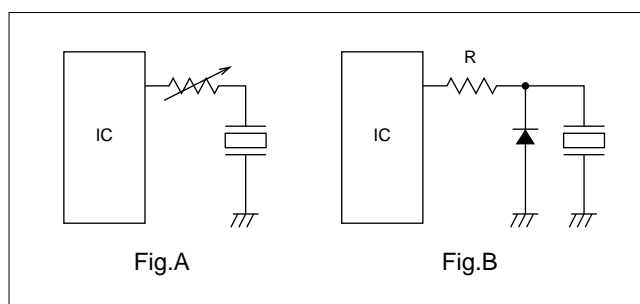

5. Please pay enough attention not to pull lead wire too much because wire may be broken or soldering point may come off.

Piezoelectric Sound Components



Piezoelectric Ringers (PIEZORINGER®)

As the result of rapid development of ICs in telephones, demand for piezoelectric sounder as telephone ringers has also rapidly increased. To effectively satisfy this rising demand, Murata provides a suitable piezoelectric sounder called "PIEZORINGER", with the following features.

■ Features

1. Extremely clear sound.
2. Since it is voltage driven, the power consumption is quite negligible.
3. It can be driven directly from ICs.
4. Extremely thin and light.



PKM33EP-1201C

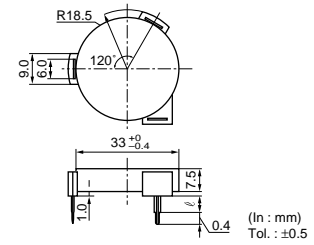

Part Number	ℓ
PKM33EP-1201C	5.0
PKM33EP-1202C	0



PKM34EW-1101C/1201C

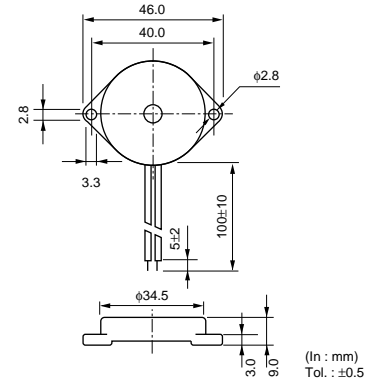

6



PKM44EP-0901

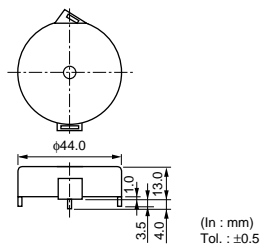

PKM44EW-1001C

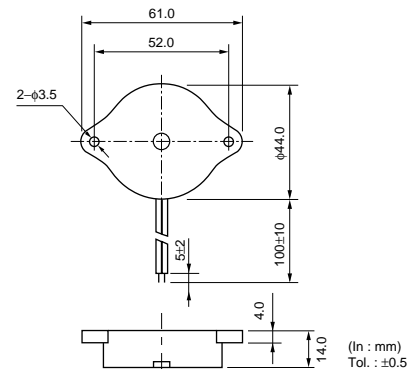

Pin Type

Part Number	Sound Pressure Level (dB)	Sound Pressure Level(Ref. only) (dB)	Operating Voltage Range (Vp-p)	Capacitance (nF)	Operating Temp. Renge	Storage Temp. Renge
PKM33EP-1201C	68 min. [30Vp-p,1.2kHz,square wave,1m]	65 min. [1Vrms,1.2kHz,sine wave,10cm]	40 max.	40 ±30% [120Hz]	-20 to +70°C	-30 to +80°C
PKM44EP-0901	70 min. [30Vp-p,1kHz,square wave,1m]	60 min. [1Vrms,1kHz,sine wave,10cm]	40 max.	68 ±30% [120Hz]	-20 to +70°C	-30 to +80°C

Lead Wire Type

Part Number	Sound Pressure Level (dB)	Sound Pressure Level(Ref. only) (dB)	Operating Voltage Range (Vp-p)	Capacitance (nF)	Operating Temp. Renge	Storage Temp. Renge
PKM34EW-1101C	70 min. [30Vp-p,1.1kHz,square wave,1m]	60 min. [1Vrms,1.1kHz,sine wave,10cm]	40 max.	40 ±30% [120Hz]	-20 to +70°C	-30 to +80°C
PKM34EW-1201C	70 min. [30Vp-p,1.2kHz,square wave,1m]	60 min. [1Vrms,1.2kHz,sine wave,10cm]	60 max.	32 ±30% [120Hz]	-20 to +70°C	-30 to +80°C
PKM44EW-1001C	75 min. [30Vp-p,1kHz,square wave,1m]	70 min. [1Vrms,1kHz,sine wave,10cm]	30 max.	68 ±30% [120Hz]	-20 to +70°C	-30 to +80°C

■ Freq. Response (Square Wave 30Vp-p, 1m)

PKM33EP-1201C

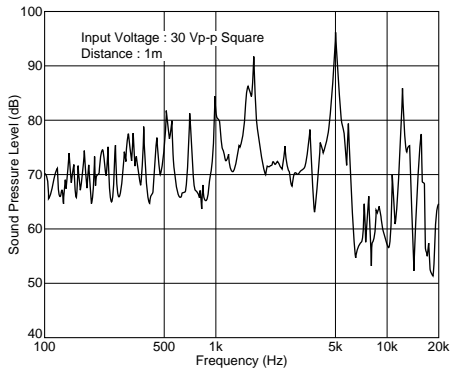

PKM44EP-0901

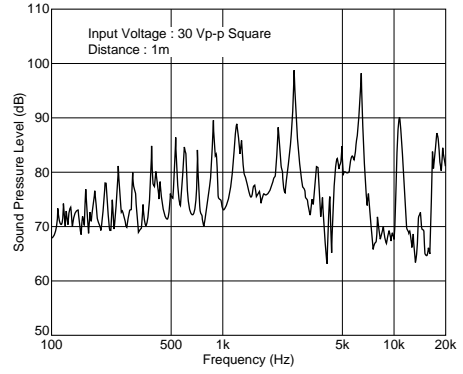

PKM34EW-1101C

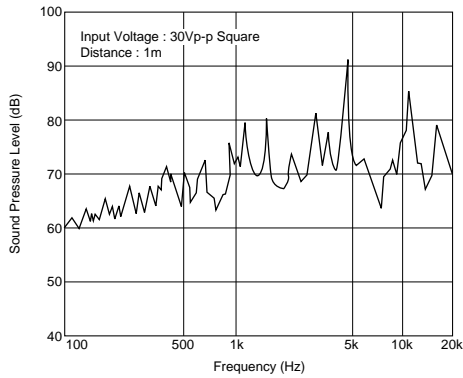

PKM34EW-1201C

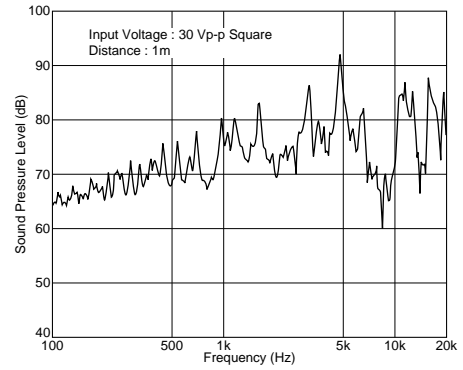

PKM44EW-1001C

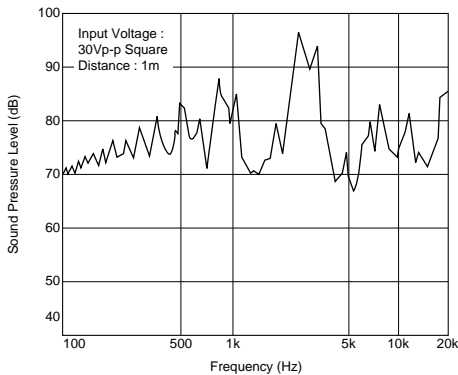

■ Freq. Response (Sine Wave 1Vrms, 10cm)

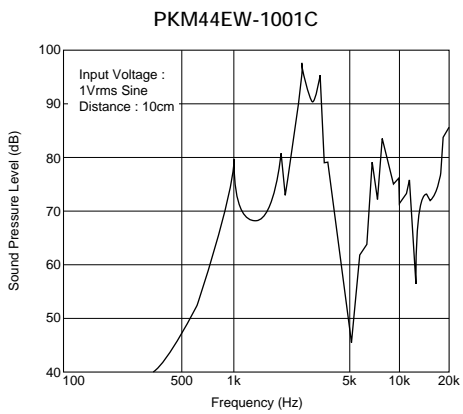
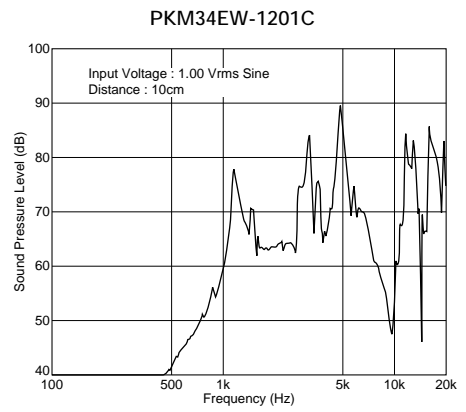
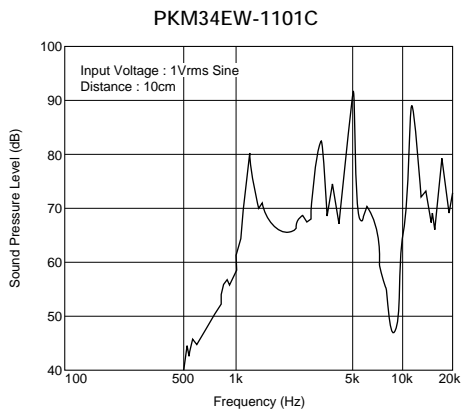
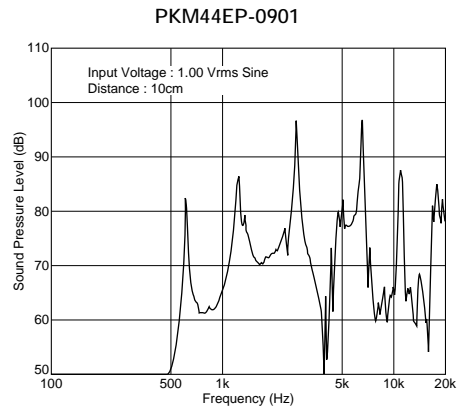
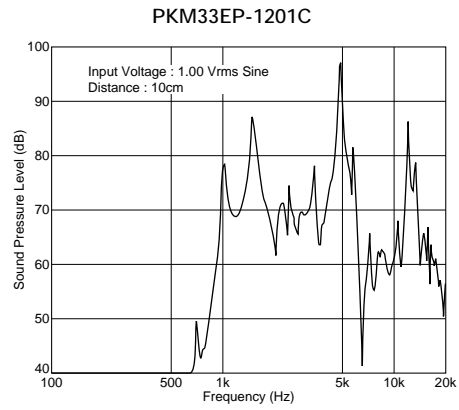

Piezoelectric Ringers (PIEZORINGER®) Notice

■ Notice (Soldering and Mounting)

Washing of the component is not acceptable, because it is not sealed.

■ Notice (Handling)

1. The component may be damaged if mechanical stress over this specification is applied.
2. Please pay attention to protect operating circuit from surge voltage provided by something of force such as falling, shock and temperature changing.
3. If DC voltage is applied to the component, silver migration may occur. Please pay full attention not to subject the component to DC voltage for long periods.
4. The resistor should be used as shown in Fig. A.
A suitable resistance value should be chosen, preferably $1\text{k}\Omega$ to $2\text{k}\Omega$. Instead of this measure, a diode may also be applied as shown in Fig. B.

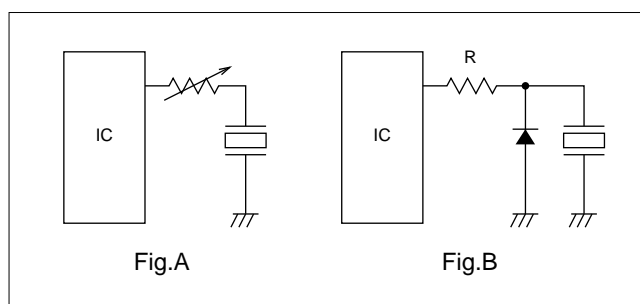

5. Please pay enough attention not to pull lead wire too much because wire may be broken or soldering point may come off.

Piezoelectric Sound Components



Piezoelectric Sounders Self-Drives Pin Type

Piezoelectric sounder self drive type requires only simple circuit and DC power supply. Since this type uses resonant system, it is also available for alarms which need large sound volume.

Applications

- Gas alarms, burglar alarms, smoke detectors.
- Air conditioners, Microwave ovens, washing machines and other home-electronic appliance controlled by microcomputer.
- Bicycles, toys, game machines.

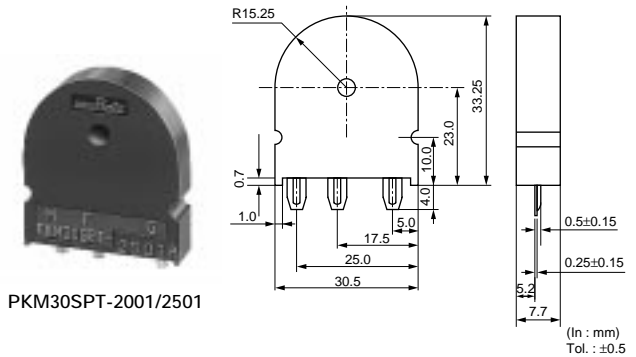

PKM30SPT-2001/2501

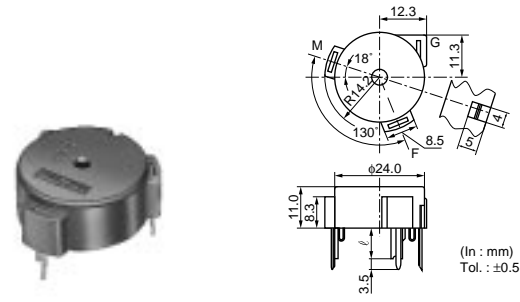

PKM24SP-3805

Part Number	ℓ
PKM24SP-3805	4.0
PKM24SP-3810	8.0
PKM24SP-3807	12.0
PKM24SP-3801	14.0

Part Number	Sound Pressure Level (dB)	Oscillating Frequency (kHz)	Current Consumption (mA)	Operating Voltage Range (Vdc)	Operating Temp. Range	Storage Temp. Range
PKM24SP-3805	90 min. [12Vdc,10cm]	3.8 ±0.4kHz [12Vdc]	12 max. [12Vdc]	3.0 to 20.0	-20 to +70°C	-30 to +80°C
PKM30SPT-2001-B0	75 min. [12Vdc,10cm]	2.0 ±0.3kHz [12Vdc]	20 max. [12Vdc]	3.0 to 20.0	-20 to +70°C	-30 to +80°C
PKM30SPT-2501-B0	75 min. [12Vdc,10cm]	2.5 ±0.3kHz [12Vdc]	20 max. [12Vdc]	3.0 to 20.0	-20 to +70°C	-30 to +80°C

Standard Circuit Examples

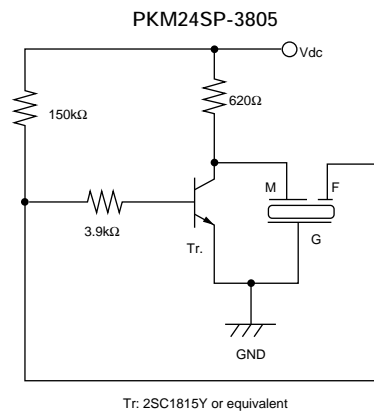
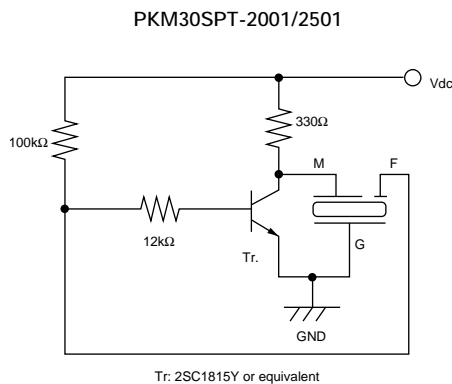

Piezoelectric Sounders (Self-Drives) Notice

■ Notice (Soldering and Mounting)

1. Washing of the component is not acceptable, because it is not sealed.
2. Please do not cover the hole with tape or other obstacle as this will produce irregular oscillation.
3. There should not be any obstacle within 15mm from top of the component as this will produce irregular oscillation.

■ Notice (Handling)

1. The component may be damaged if mechanical stress over this specification is applied.
2. Please pay attention to protect operating circuit from surge voltage provided by something of force such as falling, shock and temperature changing.
3. If DC voltage is applied to the component, silver migration may occur. Please pay full attention not to subject the component to DC voltage for long periods.
4. The standard self-driven circuits utilizes transistor switching. The circuit constants shown in the table below are optimally chosen to maintain stable oscillation. So please follow it when you design a circuit.

Piezoelectric Sound Components



Piezoelectric Buzzers

This is unified piezoelectric sounder which has piezoelectric diaphragm of 3 terminals connected to self drive circuit, and it easily generates sound with only a DC power supply (DC3.0-20V). Using suitably designed resonant system, this type can be used where large sound volumes are needed.

■ Applications

- Gas alarms, burglar alarms.
- Air conditioners, microwave ovens and various types of microcomputer controlled home-electronic appliances.
- Automobile speed alarms, navigators, car stereos and other automobile equipment.
- Toys, games, and other simple electronic devices such as teaching aids.



PKB30SPC-2001/3001

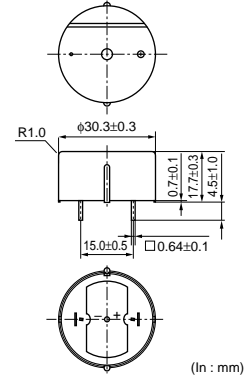

(In : mm)



PKB24SW-3301

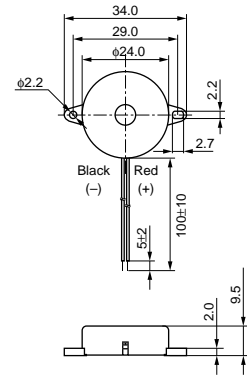

(In : mm)
Tol. : ± 0.5



PKB24SPC-3601

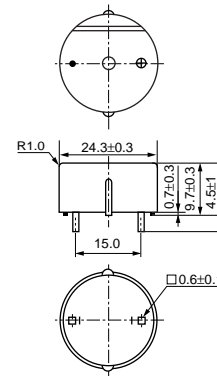

(In : mm)
Tol. : ± 0.5

Pin Type

Part Number	Sound Pressure Level (dB)	Oscillating Frequency (kHz)	Current Consumption (mA)	Operating Voltage Range (Vdc)	Operating Temp. Renge	Storage Temp. Renge
PKB30SPC-2001-B0	92 min. [12Vdc,10cm]	2.0 ±0.4kHz [12Vdc]	15 max. [12Vdc]	3.0 to 15.0	-20 to +70°C	-30 to +80°C
PKB30SPC-3001-B0	92 min. [12Vdc,10cm]	2.7 ±0.4kHz [12Vdc]	15 max. [12Vdc]	3.0 to 15.0	-20 to +70°C	-30 to +80°C
PKB24SPC-3601-B0	90 min. [12Vdc,10cm]	3.6 ±0.5kHz [12Vdc]	16 max. [12Vdc]	3.0 to 15.0	-20 to +70°C	-30 to +80°C

Lead Wire Type

Part Number	Sound Pressure Level (dB)	Oscillating Frequency (kHz)	Current Consumption (mA)	Operating Voltage Range (Vdc)	Operating Temp. Renge	Storage Temp. Renge
PKB24SW-3301	80 min. [12Vdc,10cm]	3.3 ±0.5kHz [12Vdc]	12 max. [12Vdc]	3.0 to 20.0	-20 to +70°C	-30 to +80°C

■ Voltage-Sound Pressure Level/Voltage-Consumption Current

PKB30SPC-2001

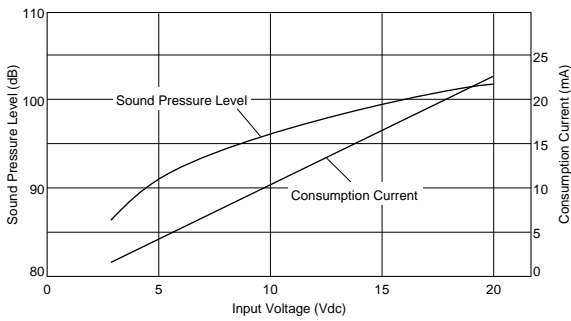

PKB30SPC-3001

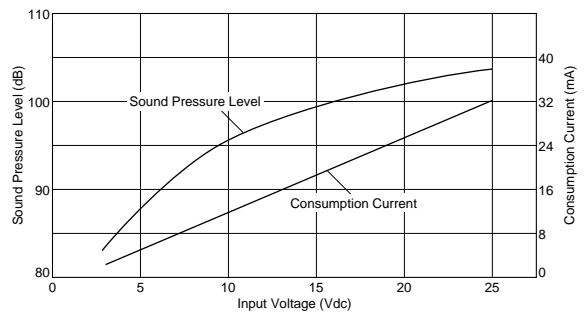

PKB24SPC-3601

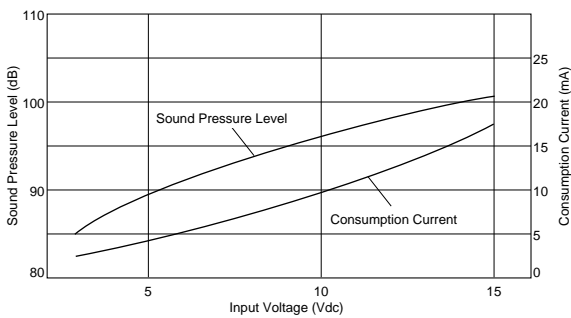

PKB24SW-3301

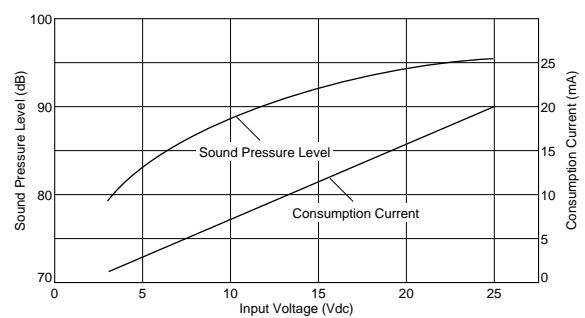

Piezoelectric Buzzers Notice

■ Notice (Soldering and Mounting)

1. Washing of the component is not acceptable, because it is not sealed.
2. Please do not cover the hole with tape or other obstacle as this will produce irregular oscillation.
3. There should not be any obstacle within 15mm from top of the component as this will produce irregular oscillation.

■ Notice (Handling)

1. The component may be damaged if mechanical stress over this specification is applied.
2. Resistors should not be connected in series to the power supply as this will produce irregular oscillation. When resistor is necessary to control sound volume, use capacitor (1 μ F) parallel with the buzzer together.

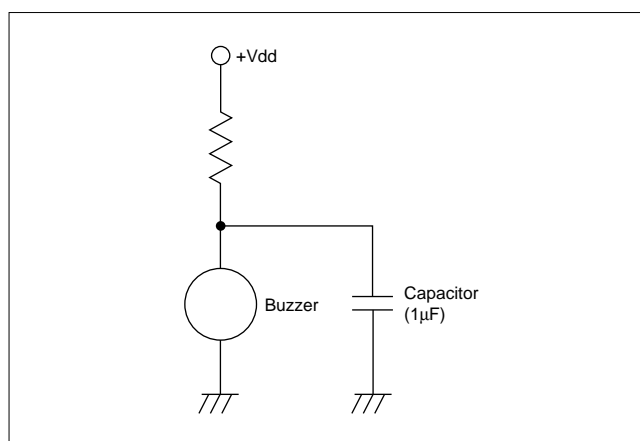

Piezoelectric Sound Components



Piezoelectric Speakers (CERAMITONE®)

As voice synthesizing techniques with ICs and LSIs are rapidly progressed, human voice synthesizing devices are put into practical use for portable calculators, clocks, vending machines, translating machines and so forth. In order to meet the demand, Murata has developed. Piezoelectric Speaker best suited for making synthesized voice or melody.

■ Features

1. High efficiency compared with conventional electromagnetic type speakers.
2. Ultra-thin and light-weight.
3. High impedance with less power consumption.
4. No electric noise, because they have no mechanical contacts.
5. Direct drive by IC is available.

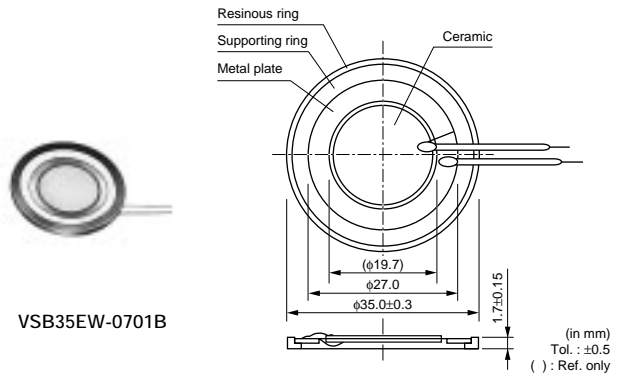

VSB35EW-0701B

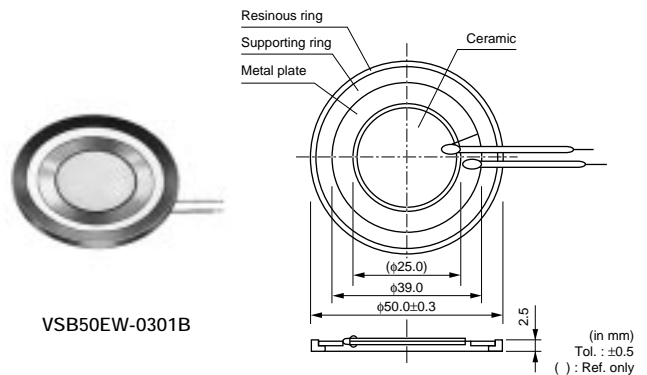

VSB50EW-0301B

Part Number	Oscillating Frequency Range	Resonant Frequency (Hz)	Impedance (ohm)	Capacitance (nF)	Maximum Input (mW)	Operating Temperature Range	Storage Temperature Range
VSB35EW-0701B	600Hz to 20kHz	950 \pm 150Hz[Lowest]	600[1kHz]	340 \pm 35%[120Hz]	75	-20 to +70°C	-30 to +80°C
VSB50EW-0301B	250Hz to 20kHz	400 \pm 150Hz[Lowest]	300[1kHz]	600 \pm 35%[120Hz]	150	-20 to +70°C	-30 to +80°C

■ Freq. Response (Sine Wave 1Vrms, 10cm)

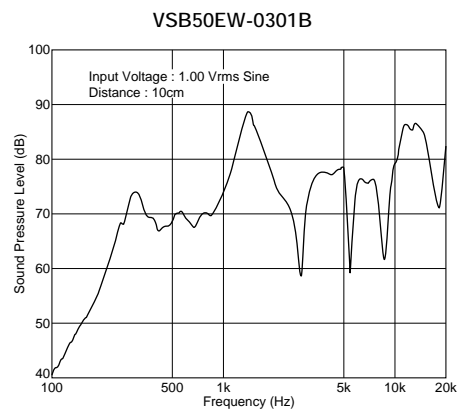
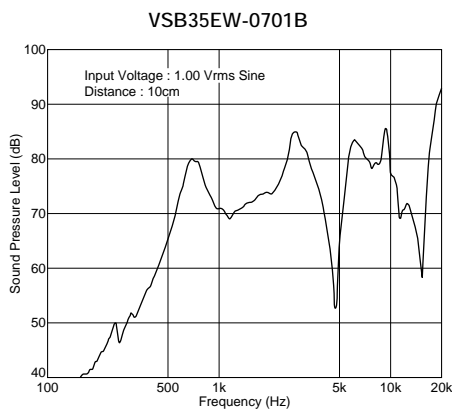

Continued on the following page.

 Continued from the preceding page.

■ Impedance-Frequency Characteristics

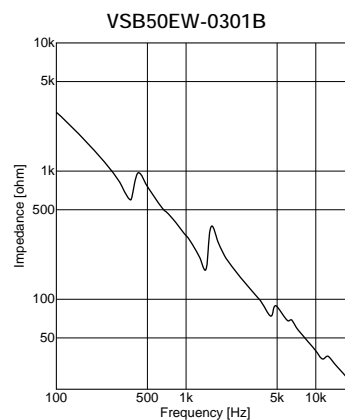
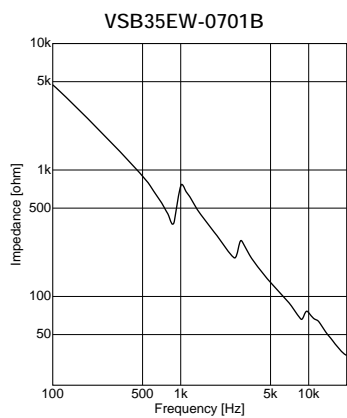

Piezoelectric Speakers (CERAMITONE®) Notice

■ Notice (Soldering and Mounting)

1. Applying load on the center area of the speaker may cause clack in the ceramic element. When the speaker is supported by edge, the load should be only applied around edge.
2. Washing of the component is not acceptable, because it is not sealed.

■ Notice (Handling)

1. Please do not touch the component with bare hand because electrode may be corroded.
2. The component may be damaged if mechanical stress over this specification is applied.
3. Please pay attention to protect operating circuit from surge voltage provided by something of force such as falling, shock and temperature changing.
4. If DC voltage is applied to the component, silver migration may occur. Please pay full attention not to subject the component to DC voltage for long periods.
5. The resistor should be used as shown in Fig. A.
A suitable resistance value should be chosen, preferably $1\text{k}\Omega$ to $2\text{k}\Omega$. Instead of this measure, a diode may also be applied as shown in Fig. B.

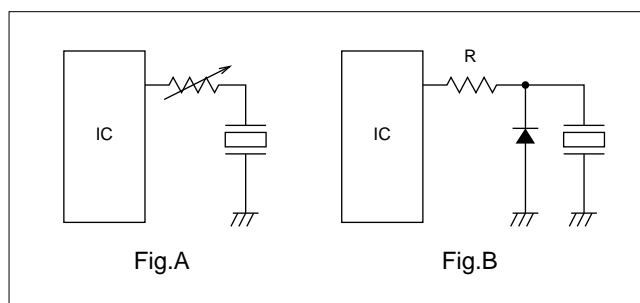

6. Please pay enough attention not to pull lead wire too much because wire may be broken or soldering point may come off.

Package

■ Minimum Quantity (pcs.)

Products Name	Part Number	Minimum Quantity (pcs.)			
		Bulk (Box)	Ammo Pack	Magazine	
● Piezoelectric Diaphragms External - Drives Type	7BB-12-9	5120			
	7BB-15-6	8000			
	7BB-20-3	3000			
	7BB-20-4	2400			
	7BB-20-6	1800			
	7BB-20-6A0	600			
	7BB-27-4	1500			
	7BB-27-4A0	600			
	7BB-35-3	800			
	7BB-35-3A0	400			
	7BB-41-2	400			
	7BB-41-2A0	250			
	7BB-50M-1	600			
	7SB-20-7	1800			
	Self - Drives Type	7BB-20-6C	1800		
		7BB-20-6CA0	600		
		7BB-27-3C	2400		
		7BB-27-4C	1500		
		7BB-27-4CA0	600		
		7BB-35-3C	800		
		7BB-35-3CA0	400		
		7BB-41-2C	600		
		7BB-41-2CA0	250		
		7NB-27-2C	3000		
		7NB-27-3C	3000		
		7NB-27-4C	3000		
		7SB-34R7-3C	1600		
● Piezoelectric Sounders External - Drives Type	PKM13EPY-4000-A0		500		
	PKM13EPY-4002-B0	330			
	PKM17EPP-2002-B0	200			
	PKM17EPP-4001-B0	200			
	PKM17EPT-4001-B0	180		70*	
	PKM17EW-2001	250			
	PKM22EP-2001	360			
	PKM22EPP-2001-B0	750			
	PKM22EPP-4001-B0	900			
	PKM22EPP-4005-B0	750			
	PKM22EPP-4007-B0	750			
	PKM22EPT-2001-B0	300		75*	
	PKM22EPT-4001-B0	300			
	PKM17EW-4000	500			
	PKMC16E-4000-T0	80			
	Self - Drives Type	PKM24SP-3805	360		
		PKM30SPT-2001-B0	70		
		PKM30SPT-2501-B0	70		
	● Piezoelectric Buzzers	PKB24SPC-3601-B0	650		
PKB24SW-3301		200			
PKB30SPC-2001-B0		80			
PKB30SPC-3001-B0		80			
● Piezoelectric Rings (PIEZORINGER®)	PKM33EP-1201C	300			
	PKM34EW-1101C	25			
	PKM34EW-1201C	25			
	PKM44EP-0901	160			
	PKM44EW-1001C	25			
● Piezoelectric Speakers (CERAMITONE®)	VSB35EW-0701B	160			
	VSB50EW-0301B	80			

*The last two digits are changed to M0.

⚠ Note:**1. Export Control**

⟨For customers outside Japan⟩

Murata products should not be used or sold for use in the development, production, stockpiling or utilization of any conventional weapons or mass-destructive weapons (nuclear weapons, chemical or biological weapons, or missiles), or any other weapons.

⟨For customers in Japan⟩

For products which are controlled items subject to the "Foreign Exchange and Foreign Trade Law" of Japan, the export license specified by the law is required for export.

2. Please contact our sales representatives or product engineers before using our products listed in this catalog for the applications listed below which require especially high reliability for the prevention of defects which might directly cause damage to the third party's life, body or property, or when intending to use one of our products for other applications than specified in this catalog.

- ① Aircraft equipment
- ② Aerospace equipment
- ③ Undersea equipment
- ④ Power plant equipment
- ⑤ Medical equipment
- ⑥ Transportation equipment (vehicles, trains, ships, etc.)
- ⑦ Traffic signal equipment
- ⑧ Disaster prevention / crime prevention equipment
- ⑨ Data-processing equipment
- ⑩ Application of similar complexity and/or reliability requirements to the applications listed in the above

3. Product specifications in this catalog are as of May 2001. They are subject to change or our products in it may be discontinued without advance notice. Please check with our sales representatives or product engineers before your ordering. If there are any questions, please contact our sales representatives or product engineers.**4. The parts numbers and specifications listed in this catalog are for information only. You are requested to approve our product specification or to transact the approval sheet for product specification, before your ordering.****5. Please note that unless otherwise specified, we shall assume no responsibility whatsoever for any conflict or dispute that may occur in connection with the effect of our and/or third party's intellectual property rights and other related rights in consideration of your using our products and/or information described or contained in our catalogs. In this connection, no representation shall be made to the effect that any third parties are authorized to use the rights mentioned above under licenses without our consent.****6. None of ozone depleting substances (ODS) under the Montreal Protocol is used in manufacturing process of us.****Murata Manufacturing Co., Ltd.**<http://www.murata.co.jp/products/>**Head Office**

2-26-10, Tenjin Nagaokakyo-shi, Kyoto 617-8555, Japan Phone:81-75-951-9111

International Division3-29-12, Shibuya, Shibuya-ku, Tokyo 150-0002, Japan
Phone:81-3-5469-6123 Fax:81-3-5469-6155 E-mail:intl@murata.co.jp