

# PIEZOELECTRIC SOUND COMPONENTS

## *APPLICATION MANUAL*



*Innovator  
in Electronics*

Murata  
Manufacturing Co., Ltd.

## **Introduction**

---

Murata is active in R&D of new electronic components, seeking infinite possibility of ceramic materials. Particularly, as a pioneer in the development of piezoelectric ceramics, Murata has met the needs of technical revolution in electronics with original products.

Our ceramic resonators (CERALOCK®), ceramic filters (CERAFIL®), piezo buzzers and various ultrasonic transducers have been contributed to the development of electronics.

The “ Piezoelectric sound components ” introduced herein operates on an innovative principle utilizing natural oscillation of piezoelectric ceramics. Today, piezoelectric sound components are used in many ways such as home appliances, OA equipments, audio equipments and telephones etc. And they are applicated widely, for examples, alarms, speakers, telephone ringers, receivers, transmitters and beep sounds etc.

This manual is made for customers to use piezoelectric sound components efficiently and with no trouble. It is recommended that the manual be read while referring to the catalog.

# CONTENTS

- 1 Type of piezoelectric sound components and Oscillating system** ..... 2
  - 1.Type of piezoelectric sound components ..... 2
  - 2.Oscillating system ..... 2
- 2 Procedures** ..... 3
  - 1.Soldering procedures ..... 3
  - 2.Design procedure ..... 3
  - 3.Drive procedure ..... 4
    - External drive method ..... 4
    - Self drive method ..... 5
- 3 Characteristics and measuring method** ..... 7
  - 1.Characteristics ..... 7
  - 2.Measuring Procedure ..... 7
    - Measurement of resonant frequency and resonant impedance..... 7
    - Measurement of sound pressure level (S. P. L.)..... 8
- 4 Environmental Characteristics** ..... 9
  - 1.Voltage and temperature characteristics ..... 9
  - 2.Environmental test..... 9

- 1** Type of piezoelectric sound components and Oscillating system
- 2** Procedures
- 3** Characteristics and measuring method
- 4** Environmental Characteristics

# 1 Type of piezoelectric sound components and Oscillating system

## 1. Type of piezoelectric sound components

TYPE	DRIVING PROCEDURES			STANDARD PARTS
	EXTERNAL DRIVE	SELF DRIVE	BUILT IN CIRCUIT	
PIEZOELECTRIC DIAPHRAGM				7BB-27-3R5
PIEZOELECTRIC SOUNDER				PKM22EPT-2001-B0
PIEZOELECTRIC BUZZER				PKB24SPC-3601-B0
PIEZOELECTRIC SPEAKER				VSB35EW-0701B

## 2. Oscillating system

Basically, sound source of a piezoelectric sound component is a piezoelectric diaphragm. A piezoelectric diaphragm consists of a piezoelectric ceramic plate which have electrodes on both sides and a metal plate (brass or stainless steel etc). A piezoelectric ceramic plate is attached to a metal plate with adhesives. Fig. 2 shows the oscillating system of a piezoelectric diaphragms. Applying D. C. voltage between electrodes of a piezoelectric diaphragm causes mechanical distortion due to the piezoelectric effect. For a disshaped piezoelectric element, the distortion of the piezoelectric element expands in radial direction. And the piezoelectric diaphragm bends toward the direction shown in Fig.2 (a). The metal plate bonded to the piezoelectric element does not expand. Conversely, when the piezoelectric element shrinks, the piezoelectric diaphragm bends in the direction shown in Fig.2 (b). Thus, when AC voltage is applied across electrodes, the bending shown in Fig.2 (a) and Fig.2 (b) is repeated as shown in Fig.2 (c), producing sound waves in the air.

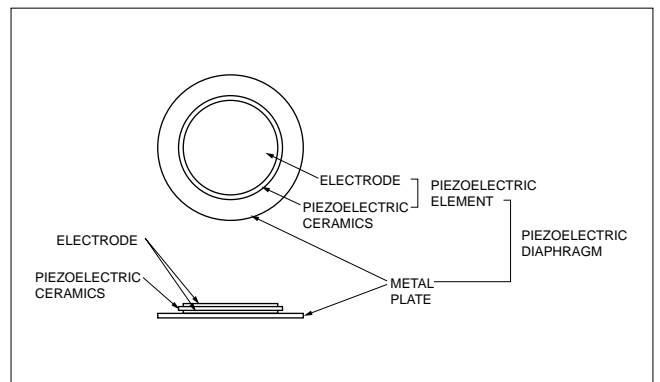

Fig. 1 Structure of piezoelectric diaphragm

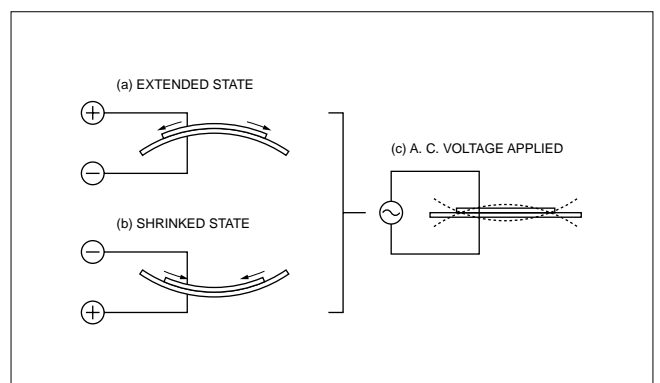

Fig. 2 Oscillation system

# 2 Procedures

## 1. Soldering procedures

A lead wire is needed to apply voltage to the piezoelectric diaphragm. When using a soldering iron, the optimum temperature for soldering a lead wire to a metal plate is 300 for a few seconds and the same temperature for the ceramic silver electrode for 0.5 second or less. The lead wire should be as fine as possible, as it works as a load restricting oscillation of the piezoelectric diaphragm. (Example: AWG32)

## 2. Design procedure

In general, man's audible frequency range is about 20 Hz to 20kHz. Frequency range of 2kHz to 4kHz are most easily heard. For this reason, most piezoelectric sound components are used in this frequency range, and the resonant frequency ( $f_0$ ) is generally selected in the same range too. As shown in Fig. 3, the resonant frequency depends on methods used to support the piezoelectric diaphragm. If piezoelectric diaphragms are of the same shape, their values will become smaller in the order of (a), (b) and (c). In general, the piezoelectric diaphragm is installed in a cavity to produce high sound pressure (Fig. 4). The resonant frequency ( $f_{cav}$ ) of the cavity in Fig. 4 is obtained from Formula (1) (Helmholtz's Formula). Since the piezoelectric diaphragm and cavity have proper resonant frequencies, ( $f_0$ ) and ( $f_{cav}$ ) respectively, sound pressure in specific frequencies can be increased and a specific band width can be provided by controlling the both positions.

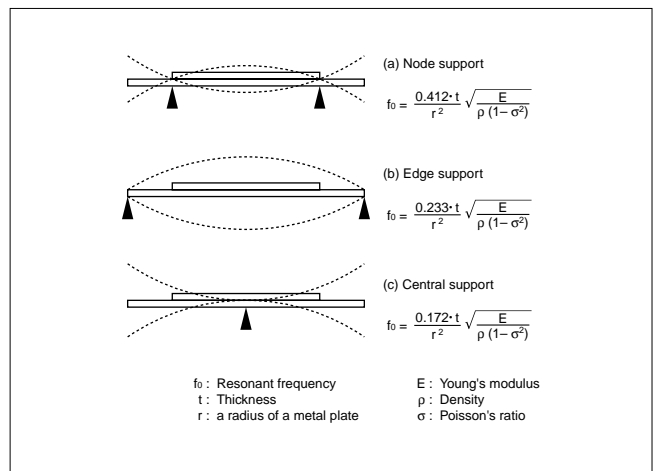

Fig. 3 Supporting method

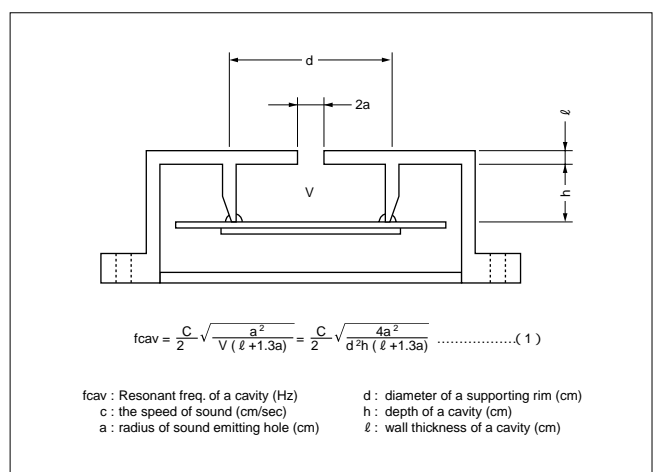

Fig. 4 Sectional view of a cavity

## 2 Procedures

### 3. Drive procedure

Drive procedures for piezoelectric sound components include (a) external drive method and (b) self drive method as shown in Fig. 5.

#### External drive method

This method produces sound by driving the piezoelectric diaphragm with electric signals supplied from an external oscillating circuit such as a multivibrator. Using this method, the piezoelectric buzzer can work as a speaker. In this method, a mechanical oscillation  $Q_m$  of the piezoelectric diaphragm is damped properly to provide a wider frequency band of the sound pressure. This is applied to a switching sounds of home electric appliances, key-in sounds of OA equipments, alarm sounds of digital watches and the multiple sounds like those used in electronic games. This method is also applied to the ringers, transmitters, receivers of telephone sets, tweeters, card radios and speakers of crystal TV's. Fig. 6 shows the examples of the circuit to which the external drive method is applied.

(i) represents a circuit in which output signals of the unstable multivibrator are boosted through the coil and transistors. (ii) represents a circuit using 2 NAND gates, which is oscillated or stopped by ON / OFF operations of the input signal. (iii) and (iv) represent example of the piezoelectric diaphragm connected to telephone tone ringer IC.

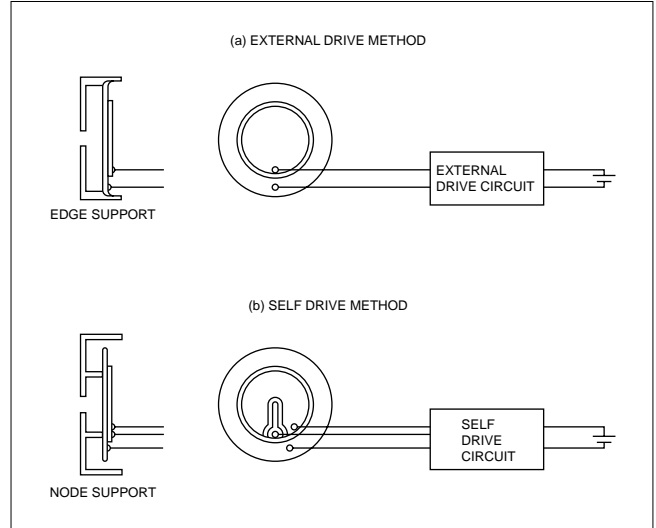

Fig. 5 Drive procedure

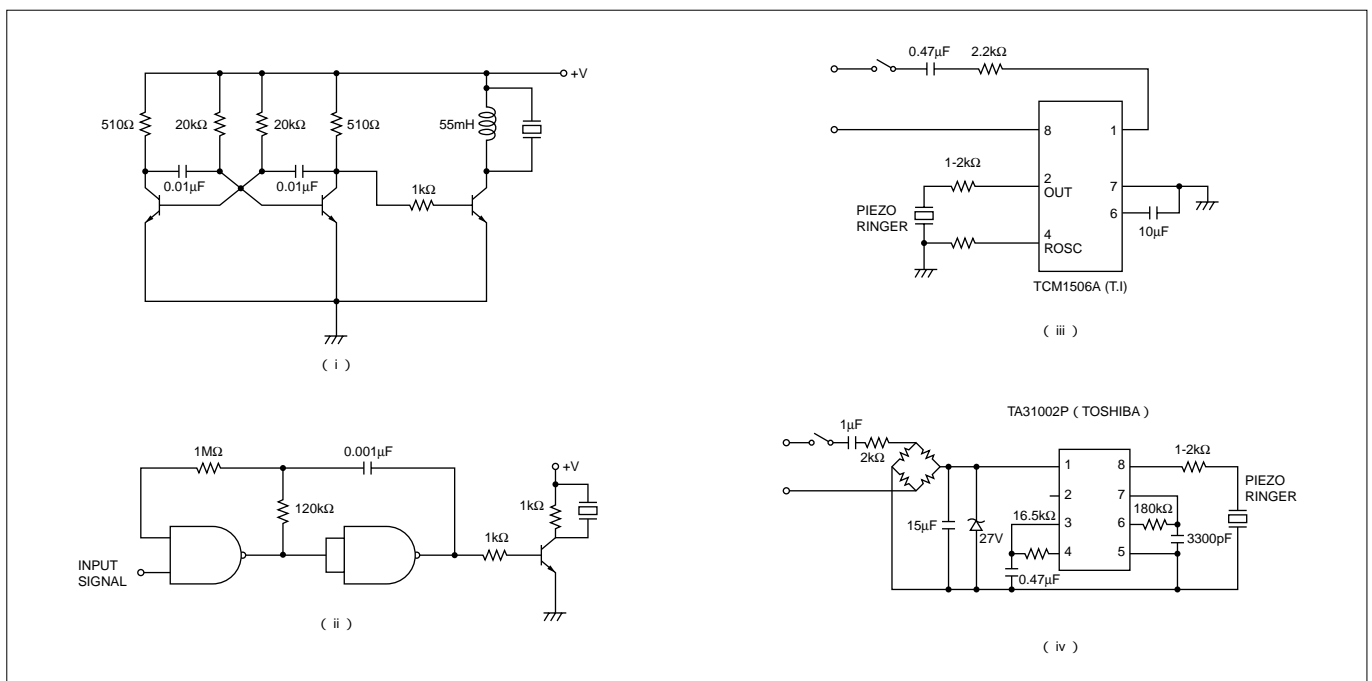

Fig. 6 Example's of the external drive circuit

**Notice (handling) in using external drive circuit**

- 1) Electric charges accumulated in the piezoelectric diaphragm due to thermal and mechanical shock may cause high voltage which may destroy LSI. Use the method using a Zener diode as shown in Fig. 7 to prevent this.
- 2) Applying D. C. voltage to the piezoelectric diaphragm in the environment of high humidity causes Ag migration. Therefore, design a circuit which does not require D. C. voltage be applied for a long time.
- 3) Consider the following points in connecting a piezo ringer and tone ringer IC.
  - i) For external capacitors and resisters; especially, when the ringing frequency is changed by adjusting variable resister, tone may be distorted.
  - ii) Ringer ICs; ringer ICs are produced by many manufactures have different characteristics. When using a ringer IC, consult us or its manufacturer for operating procedures.
  - iii) If tone is distorted as discribed in Fig. 8 (a), place a resister in series to vary resistance as described in (b) and select a resistance with which the distortion can be eliminated. The recommended resistance is in a range between 1kohms to 2kohms. Alternatively, it is recommended to place a diode in parallel with the piezo ringer.

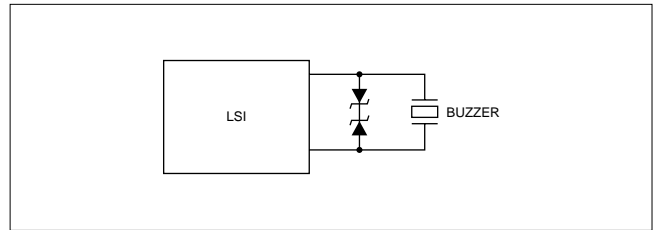

Fig. 7 Protect circuit

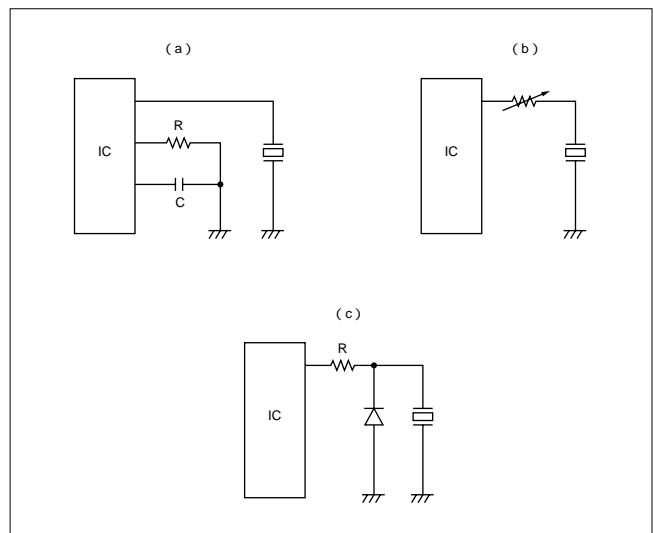

Fig. 8 Circuits for piezo ringer

**Self drive method**

Fig. 9 shows a typical application of the self drive method. The piezoelectric diaphragm provided with feedback electrode shown in Fig.9 (i) is involved in the closed loop of a hartley types oscillation circuit. When the frequency is closed to the resonant frequency, the circuit satisfies oscillating conditions, and the piezoelectric diaphragm is driven with the oscillating frequency. Fig. 9 (ii) shows a simple oscillating circuit consisting of one transistor and three resistors. In general, the node support shown in Fig. 3 (a) is popular in the self drive method. Proper resonance of the piezoelectric diaphragm by the node support provides stable oscillation with high mechanical Qm of vibration but also a single high pressure tone.

Basic oscillating conditions of this circuit are shown below.

- a. Phase difference between  $v_o$  and  $v_f$  shown in Fig. 9 must be 180 degrees.
- b. The following conditions must be satisfied:
 
$$v_f / v_o \geq \frac{R_2 + h_{ie}}{h_{fe} \cdot R_3}$$
 where;
  - $h_{ie}$ : Input impedance of transistor
  - $h_{fe}$ : Current amplification
- c. Set  $R_1$  so that the D. C. bias point of transistor, VCE is half of supply voltage.
- d. Adjust  $R_2$  so that spurious oscillation is not applied to oscillating waves.

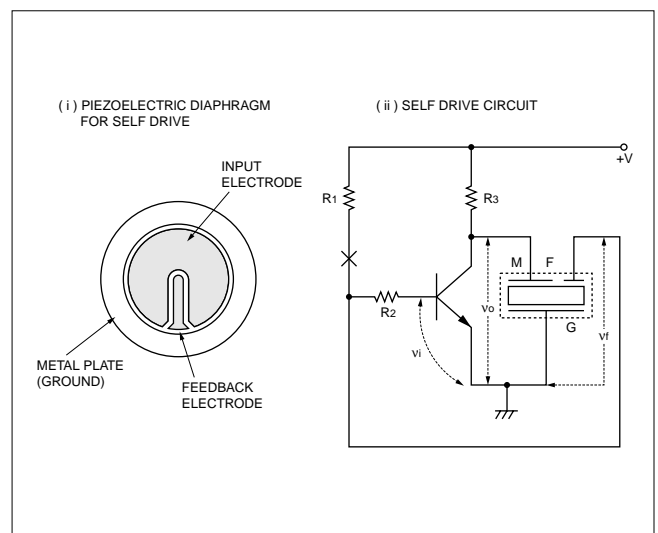

Fin. 9 Self drive circuit

## 2 Procedures

### Notice (handling) in using self drive method

- 1) When the piezoelectric buzzer is set to produce intermittent sounds, sound may be heard continuously even when the self drive circuit is turned ON / OFF at the " X " point shown in Fig. 9. It is because of the failure of turning off the feedback voltage.
- 2) Builed up a circuit of the piezoelectric sounder exactly as per the recommended circuit shown in the catalog.  $h_{fe}$  of the transistor and circuit constants are designed to ensure stable oscillation of the piezoelectric sounder.
- 3) Design switching which ensures direct power switching.
- 4) The self drive circuit is already contained in the piezoelectric buzzer. So there is no need to prepare an another circuit to drive the piezoelectric buzzer.
- 5) Rated voltage (3.0 to 20Vdc) must be kept. Products which can operate with voltage higher than 20Vdc are also available.
- 6) Do not place resistors in series with the power source, as this may cause abnormal oscillation. If a resistor is essential to adjust sound pressure, place a capacitor (about  $1\mu F$ ) in parallel with the piezo buzzer.

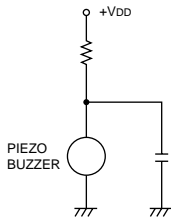

- 7) Do not close the sound emmitting hole on the front side of casing.
- 8) Carefully install the piezo buzzer so that no obstacle is placed within 15mm from the sound release hole on the front side of the casing.



# 3 Characteristics and measuring method

## 1. Characteristics

TYPE	RESONANT FREQUENCY	RESONANT IMPEDANCE	CAPACITANCE	SOUND PRESSURE LEVEL	OSCILLATING FREQUENCY	CURRENT CONSUMPTION	INPUT VOLTAGE	OPERATING VOLTAGE
PIEZOELECTRIC DIAPHRAGM								
PIEZOELECTRIC SOUNDER (EXTERNAL DRIVE)								
PIEZOELECTRIC SOUNDER (SELF DRIVE)								
PIEZOELECTRIC BUZZER								
PIEZOELECTRIC SPEAKER								
REMARKS	COMMON CONDITIONS: OPERATING TEMP. RANGE / STORAGE TEMP. RANGE MEASUREMENT INSTRUMENTS: LCR METER (CAPACITANCE) / FREQ. COUNTER (OSCILLATING FREQ.) MULTI METER (CURRENT CONSUMPTION)							

## 2. Measuring Procedure

### Measurement of resonant frequency and resonant impedance

When the piezoelectric diaphragm oscillates freely in air, the node does not move as shown in Fig. 10. With this point held with a measuring terminal, the resonant frequency ( $f_0$ ) and resonant impedance ( $R_0$ ) are measured in the constant-current circuit.

### Measuring procedure

- 1) Connect the switch to side " a " , and adjust frequency of the oscillator to read the frequency and the voltage when the voltmeter indicates a minimum value.
- 2) Then connect the switch to side " b " , and vary the variable resistor to have the same voltage as in 1). Then, read the value of the resistor.
- 3) The resonant frequency ( $f_0$ ) can be obtained from 1) and the resonant impedance ( $R_0$ ) from 2).

\*: Actual measurement are performed using a measuring unit in accordance with the above principle.

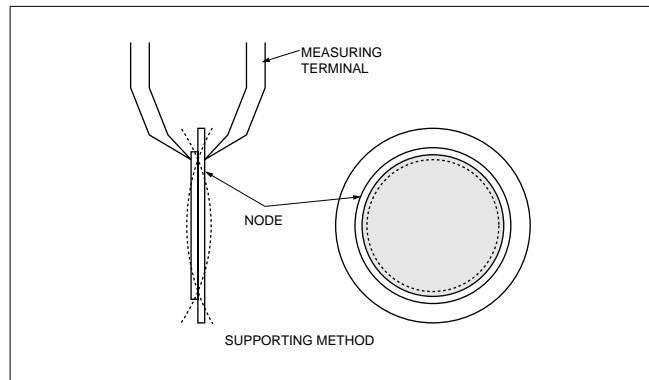

Fig. 10 Measurement of piezoelectric diaphragm

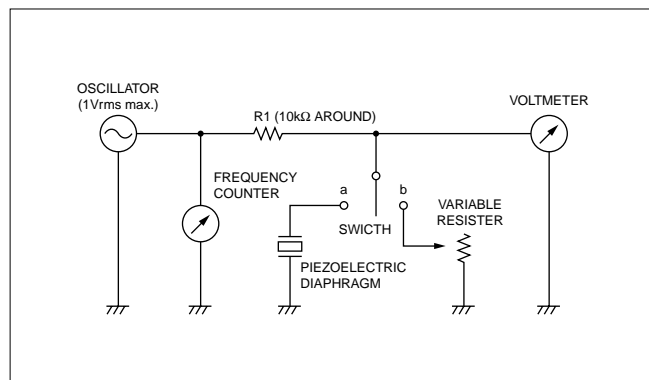

Fig. 11 Measurement set up of resonant freq. and resonant impedance

### 3 Characteristics and measuring method

#### Measurement of sound pressure level (S. P. L.)

The sound pressure level is measured with a sound pressure level meter as shown in Fig. 12 (Fig. 12 shows an example of the self drive piezoelectric sounder).

\*: The relation between sound pressure level and distance, between sound pressure level and voltage can be expressed with Formula (2). The value of the sound pressure level under different operating conditions can be easily calculated using values specified in the catalog.

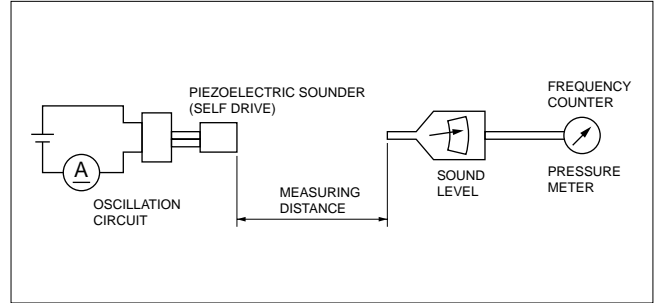

Fig. 12 Measurement set up of S. P. L.

$$\begin{aligned}
 & \text{S. P. L. (dB) [under actual operating conditions]} \\
 & = \text{S. P. L. (dB) [value specified in catalog]} \\
 & \quad - 20 \log A/B \text{ (dB)} \dots\dots\dots (2)
 \end{aligned}$$

In case of relation with distance:

- A; Actual distance
- B; Distance specified in catalog

In case of relation with voltage:

- A; Voltage specified in catalog
- B; Actual operating voltage

# 4 Environmental Characteristics

Various environmental changes such as change in room temperature and atmosphere and vibration should be considered at storage instillation and actual operation of the piezoelectric buzzer. Typical voltage and temperature characteristics and environmental tests are shown using the piezoelectric sounder PKM24SP-3805 as an example.

## 1. Voltage and temperature characteristics

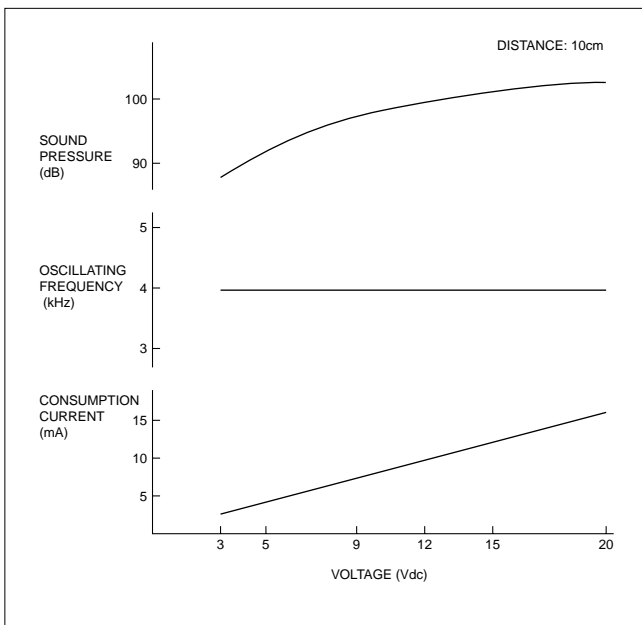

Fig. 13 Voltage characteristics

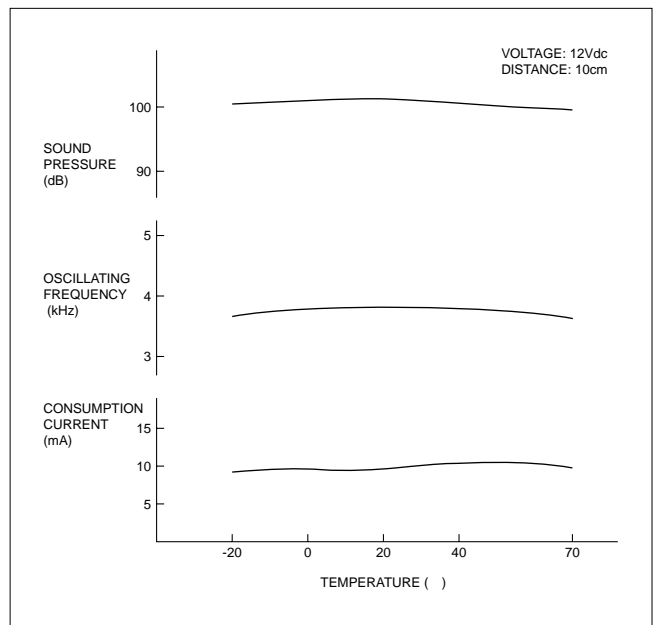

Fig. 14 Temperature characteristics

## 2. Environmental test

No	ITEM	CONDITION	DEVIATIONS
1	High temperature	+85±2 , 240Hrs	S. P. L. : Initial value ±10dB Oscillating freq. : Initial value ±10% Consumption current : Initial value ±10%
2	Low temperature	-40±2 , 240Hrs	
3	Humidity	+60±2 , R.H. 90-95%, 240Hrs	
4	Temperature cycle	Following cycle 5times; -40±2 (30min.) +20 (15min.) +85±2 (30min.) +20 (15min.)	
5	Vibration	10 to 55Hz (1 cycle, 1 min. ) Amplitude 1.5 mm 2 Hrs for each three mutually perpendicular directions	
6	Shock	+100G sine wave 3 times for each three mutually perpendicular direction	

After following test, samples should be left at natural condition (Temp.: 25°C) for more than 4 hours.

**⚠ Note:****1. Export Control**

⟨For customers outside Japan⟩

Murata products should not be used or sold for use in the development, production, stockpiling or utilization of any conventional weapons or mass-destructive weapons (nuclear weapons, chemical or biological weapons, or missiles), or any other weapons.

⟨For customers in Japan⟩

For products which are controlled items subject to the "Foreign Exchange and Foreign Trade Law" of Japan, the export license specified by the law is required for export.

**2. Please contact our sales representatives or product engineers before using our products listed in this catalog for the applications listed below which require especially high reliability for the prevention of defects which might directly cause damage to the third party's life, body or property, or when intending to use one of our products for other applications than specified in this catalog.**

- ① Aircraft equipment
- ② Aerospace equipment
- ③ Undersea equipment
- ④ Power plant equipment
- ⑤ Medical equipment
- ⑥ Transportation equipment (vehicles, trains, ships, etc.)
- ⑦ Traffic signal equipment
- ⑧ Disaster prevention / crime prevention equipment
- ⑨ Data-processing equipment
- ⑩ Application of similar complexity and/or reliability requirements to the applications listed in the above

**3. Product specifications in this catalog are as of May 2001. They are subject to change or our products in it may be discontinued without advance notice. Please check with our sales representatives or product engineers before your ordering. If there are any questions, please contact our sales representatives or product engineers.****4. The parts numbers and specifications listed in this catalog are for information only. You are requested to approve our product specification or to transact the approval sheet for product specification, before your ordering.****5. Please note that unless otherwise specified, we shall assume no responsibility whatsoever for any conflict or dispute that may occur in connection with the effect of our and/or third party's intellectual property rights and other related rights in consideration of your using our products and/or information described or contained in our catalogs. In this connection, no representation shall be made to the effect that any third parties are authorized to use the rights mentioned above under licenses without our consent.****6. None of ozone depleting substances (ODS) under the Montreal Protocol is used in manufacturing process of us.**

---

***muRata* Murata Manufacturing Co., Ltd.**<http://www.murata.co.jp/products/>

**Head Office**  
2-26-10, Tenjin Nagaokakyo-shi, Kyoto 617-8555, Japan Phone:81-75-951-9111

**International Division**  
3-29-12, Shibuya, Shibuya-ku, Tokyo 150-0002, Japan  
Phone:81-3-5469-6123 Fax:81-3-5469-6155 E-mail:intl@murata.co.jp

**Cat. No. P15E-5**