

# T/R LOCATOR

Charles D. Rakes

The transmitter/receiver metal locator (Fig. 1) is better suited to locate large metal objects at greater depths than the frequency-shift type of locator. The better transmitter/receiver locators are capable of detecting large metal objects at depths of over 25 feet. This type of locator operates on the principle that transmitted radio-frequency electromagnetic waves are distorted and reflected when they strike a metal object. The reflected waves which are detected by the receiver indicate that a metal object is within the electromagnetic field pattern of the transmitter.

The two loops are mounted at right angles to each other and offer a minimum amount of coupling between them. Fig. 1 shows how the electromagnetic field pattern is positioned around the transmitter loop. The receiver is capable of receiving an induced signal with the same field pattern as produced by the transmitter. The best operating-frequency range is between 50 kHz and 500 kHz.

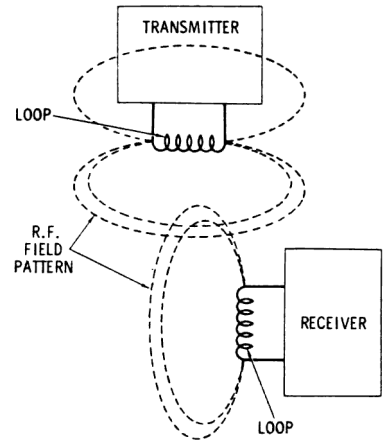

Figure 1: Transmitter/receiver locator.

## TREASURE WITCHER

The Treasure Witcher is a deep-searching metal locator. It will enable you to locate larger metal objects at greater depths than with a frequency-shift locator. A large metal chest or a wooden box filled with metal will easily be detected several feet beyond the range of the frequency-shift type units.

Two separate units are required in the Witcher: a simple transmitter and a receiver, both of which use a loop coil in their tuned circuit. The loop coil also functions as a highly directional antenna.

When the two loop antennas are at right angles to each other, the signal coupled from the transmitter to the receiver is at a minimum and the meter will read zero. But bring a metal object within range of the Witcher and the transmitted rf field will be reflected to the receiver loop. This reflected signal will be picked up by the receiver, indicated by the meter, and heard on the earphones.

## Circuit Description

*Transmitter* - As shown in Fig. 2, transistor Q1 and its associated components L1, C1, C2, C3, pi, R2, and R3 form an oscillator circuit. The operating frequency, which is in the rf range, is determined by the loop and the three capacitors. The three resistors are used to set the operating bias and the output level of the oscillator.

Unijunction transistor Q2 operates as a relaxation oscillator and produces a low-frequency audio tone. This audio signal is coupled to the base of Q1 through C4 and modulates the rf oscillator (Q1). The modulated signal can be received by a conventional receiver circuit that extracts the signal and indicates the location of the hidden metal object.

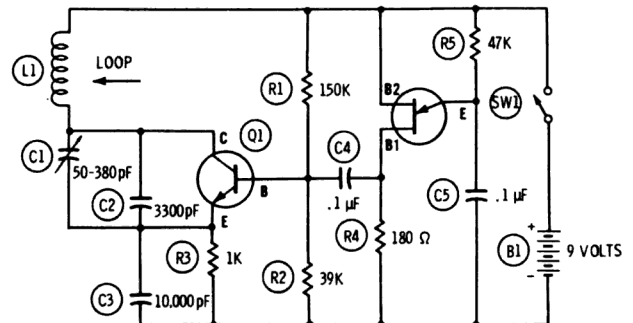

Figure 2: Transmitter circuit.

*Receiver* - The receiver circuit (Fig. 3) is designed around a very high-gain, linear IC that contains three separate high-gain amplifiers. When connected in a cascade amplifier configuration, the IC has a gain of 129 dB.

The first IC amplifier stage is connected to the tuned circuit as an rf amplifier and is used to increase the minute signal available at the loop antenna to a level that can be demodulated into a useful audio signal. The network composed of D2, C7, and R3 performs the demodulation. The demodulated signal appears across gain control potentiometer R3 and is directed to the second amplifier stage through the potentiometer wiper. This audio signal is once more amplified by the remaining IC amplifier stage. The output is directed to the meter circuit and supplies an audio tone for the earphones which are plugged into jack J1.

## Construction

*Transmitter* - Because it will be needed to check and tune the receiver, start with the transmitter. The first step is to drill and cut all holes in the case to correspond with those shown in Fig. 4. This must be done with care as the case material will damage easily if abused. After the cutting and drilling have been completed, the loop coil should be wound on the perimeter of the case (Fig. 5).

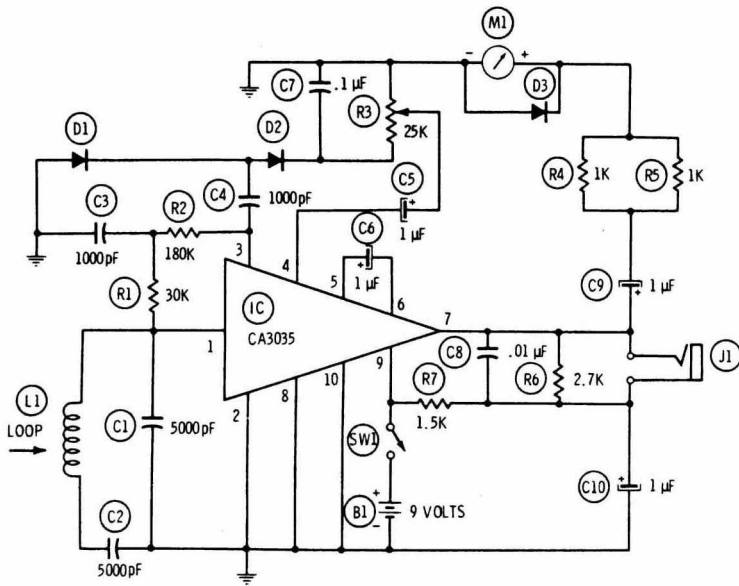

Figure 3: Receiver circuit.

**Parts List for Witcher Transmitter**

Item No.	Description
B1	9-volt transistor battery, Type 216 BP, etc.
C1	50 to 380 pF midget trimmer capacitor.
C2	3300 pF mica or polystyrene capacitor.
C3	10,000 pF mica or polystyrene capacitor.
C4, C5	.1 $\mu$ F, 200-volt tubular capacitors.
L1	Loop coil, 34 turns of No. 22 enameled wire, close-wound on outside of case.
Q1	2N2924 transistor (GE).
Q2	2N2646 unijunction transistor (GE).
R1	150K, 1/2-watt resistor.
R2	39K, 1/2-watt resistor.
R3	1K, 1/2-watt resistor.
R4	180-ohm, 1/2-watt resistor.
R5	47K, 1/2-watt resistor.
SW1	Spst, miniature toggle switch.
Misc.	6 13/16 $\times$ 5 9/32 $\times$ 2 5/16-inch plastic case, matching cover, 48-inch length of aluminum conduit, battery holder, hex spacers, wing nut, spring, etc.

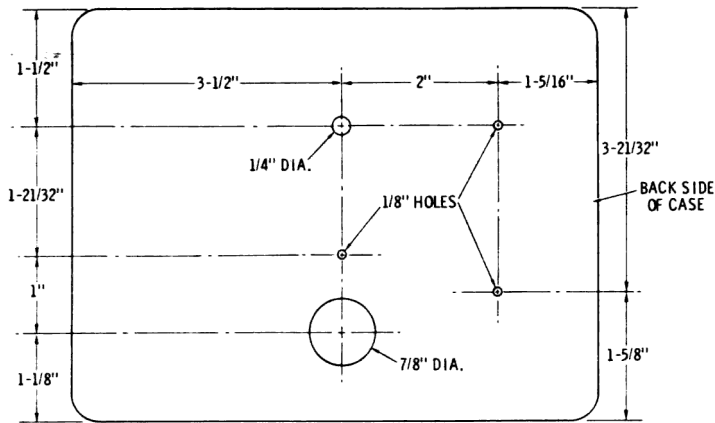

Figure 4: Transmitter Housing.

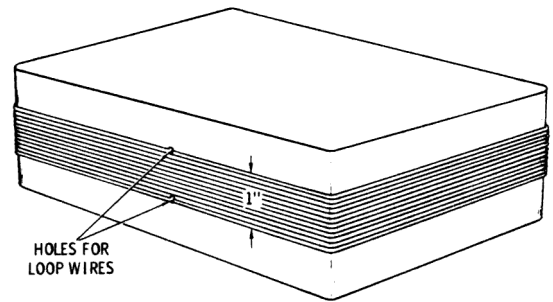

Figure 5: Receiver/transmitter loop location.

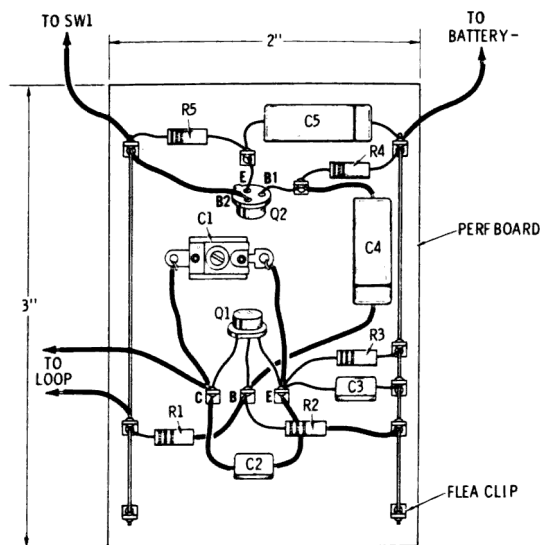

Figure 6: Transmitter parts layout.

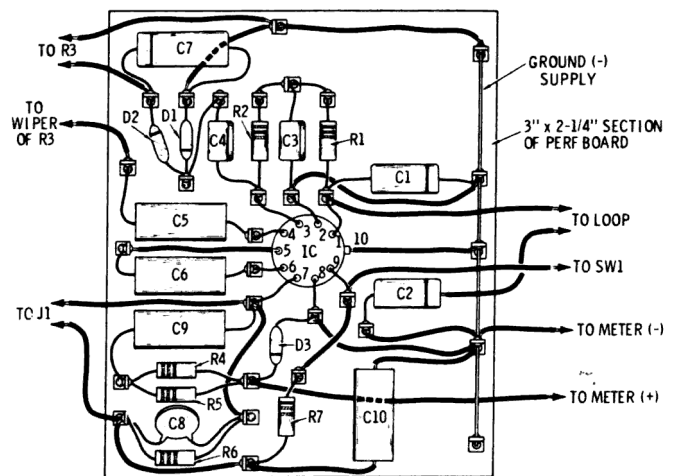

Figure 7: Receiver parts layout.

Tape the coil with a good quality cloth tape. This will help protect against coil damage during construction and treasure hunting. All components should be mounted and wired to correspond with the transmitter schematic and to match the drawing in Fig. 6.

The transmitter can be checked to determine if both of the oscillators are working by turning it on near an a-m broadcast radio and tuning the radio until you pick up a signal with a steady tone. The tone will sound like a high-speed buzz saw and will be easily recognized.

*Receiver* - Construction can follow the same basic steps used for the transmitter, except that all circuit parts are located on the cover instead of the case. Construction is done in this manner to make wiring easier and to take advantage of the structural strength of the case when mounting the receiver to the aluminum conduit.

The receiver will function best if construction matches the drawing in Fig. 7. The metal case of the gain control R3 must be connected to the negative side of the circuit. This can be done by soldering a wire from the case of the control to the circuit ground. The loop coil should be wound to match exactly the transmitter loop in Fig. 5. A plug and socket are used in the receiver to link the circuit to the loop antenna.

After the receiver has been completed, it is necessary to tune the transmitter to the receiver frequency. To do this, first turn on both units and place them several feet apart. Next, slowly tune the transmitter trimmer capacitor C1 until the meter on the receiver indicates a maximum current. If for any reason the transmitter will not tune to the receiver frequency, try a smaller or larger value for C2. After making a capacitor change, carefully retune the trimmer until a maximum meter reading is obtained. With the units properly tuned, the receiver should be capable of receiving the transmitter at a distance of at least 25 feet. When properly tuned, the Witcher will be operating near 180 kHz, but the frequency can vary by as much as 20 kHz without affecting the overall performance of the locator.

*Final assembly* - The transmitter case is fastened to the aluminum conduit with two nuts. The conduit goes through the case. The nuts are homemade and are fabricated by cutting a coupling, threaded to fit the conduit, into two equal parts. The two nuts must be filed flat, so that an equal bearing surface will support the case without causing breakage.

The receiver case is connected to the balance bracket with two 6-32 screws and matching nuts (Fig. 8 and 9). The receiver hinge is mounted to the opposite side of the case with an 8-32 screw and nut.

The receiver is then hinged to the aluminum conduit with a 1/2 inch 8-32 screw, two flat washers, and a nut. This screw, washer, and nut combination should be tight, but with enough play to allow the balance adjustment to be made smoothly.

A 2-1/2 inch 8-32 screw is bolted to the aluminum conduit below the balance bracket and held in place with a washer and nut. A coil spring and flat washer separate the conduit and balance bracket. On top of the bracket are a flat washer and a wing nut which function as a balance adjustment. The handle is made of conduit and should be shaped to match the drawing. A 2-3/4 inch 8-32 screw, washer, and nut mount the handle to the conduit. Fig. 10 shows the completed unit.

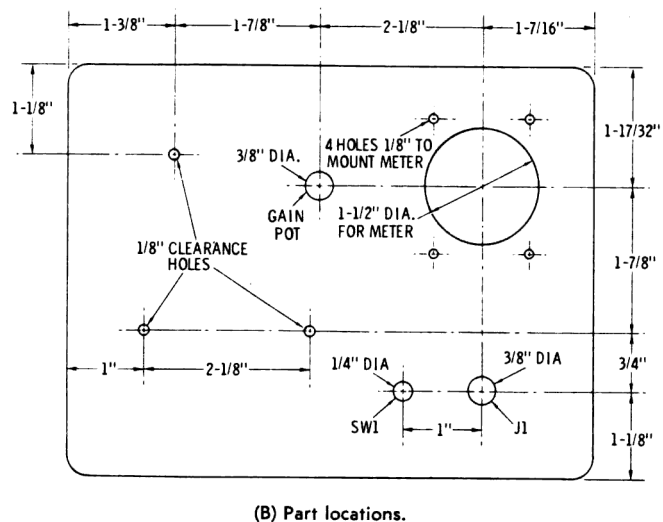
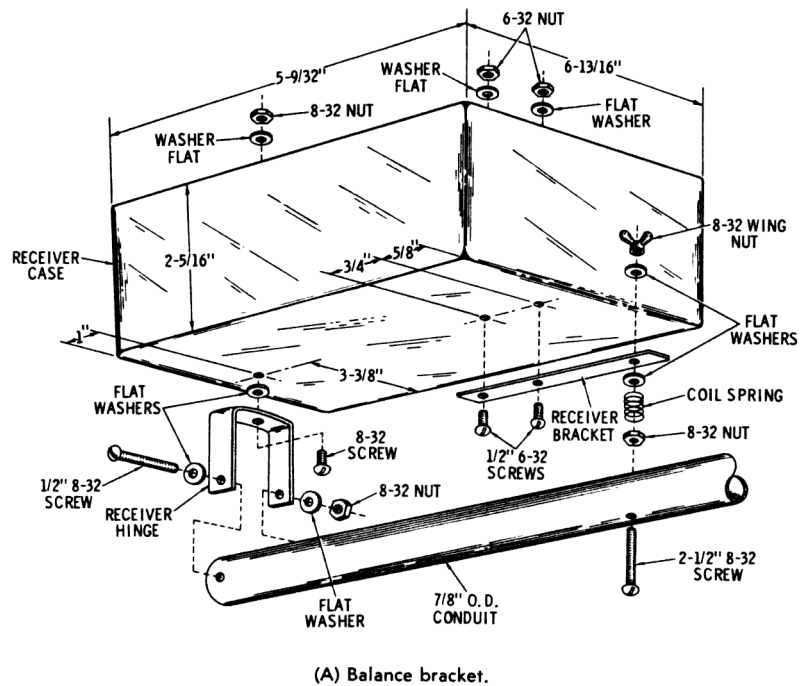

**Figure 8:** Receiver case construction details.

## Operation

Turn on both units and set the receiver gain control to midposition. The receiver should respond to the transmitter by giving a meter indication and producing an audio tone in the earphones.

Start with the balance bracket at its upper limit of adjustment and slowly turn the wing nut clockwise until the meter reading drops to near zero. Then raise the gain and readjust the balance until a minimum meter reading is again obtained.

If a plastic handle is used instead of the conduit, a slight imbalance will occur when the wing nut is touched. With care, however, a balance adjustment can be easily done.

If everything checks out all right, you are ready for a trial run with your locator. If you have not previously used a transmitter/receiver metal locator, a little practice may be in order. Place coffee cans, pie pans, or other good-sized metal objects on the ground and use the Witcher to locate them. Actually, when the balance adjustment is set so that the meter will read up scale a division or two, the unit is more sensitive. This adjustment should be made away from any metal.

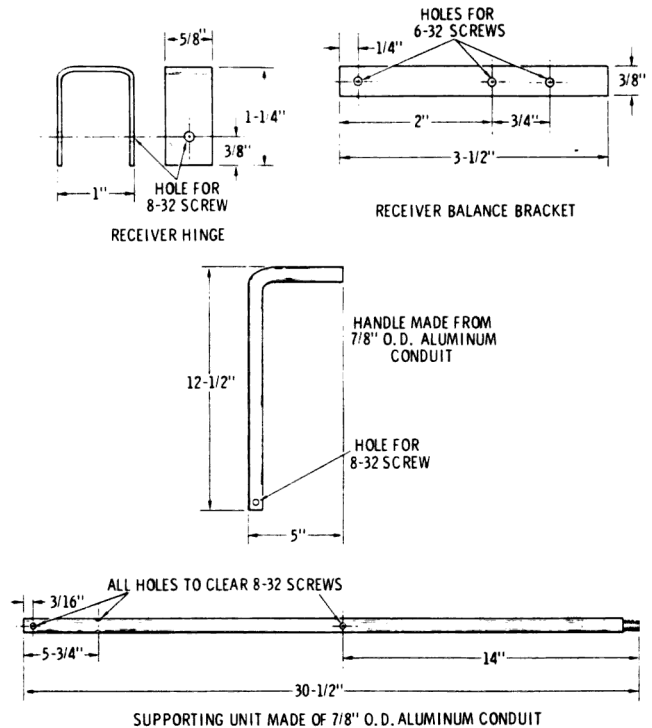

**Figure 9:** Metal parts for Witcher.

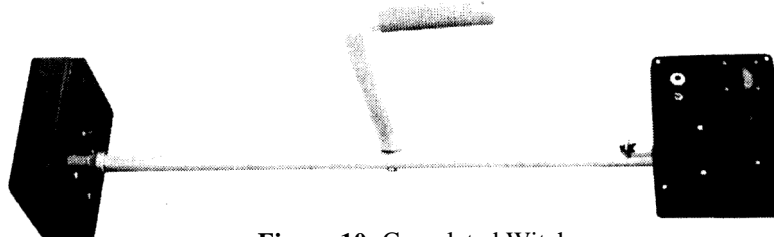

**Figure 10:** Completed Witcher.