

PE MAGNUM METAL LOCATOR Part 3

ANDY FLIND

Since the original Magnum design was published some worthwhile improvements and modifications have been carried out to the prototype which constructors might like to incorporate into their own machines. This is also a good opportunity to answer a few of the more frequent queries regarding this design.

INSTABILITY

Some constructors have run into problems of instability, usually in the form of hunting around the threshold point. Despite its high gain and sensitivity the Magnum is an exceptionally stable circuit, so if you have a stability problem it follows that there must be a cause somewhere. A not too obvious cause of such a problem is the family telly, as the line timebase of a UHF TV is very close to the Magnum's search frequency. Depending on just how close your Magnum's oscillator is to the TV line output frequency the result can be anything from a mushy, imprecise threshold settling to a quavering effect or even a slow, regular drift, caused by the two frequencies beating together. Fortunately most actual search sites don't have TVs nearby, so most of the problems you'll encounter from this cause will be during indoor testing only. Another possible source of such trouble which needs only a brief mention is that the connection point for the separate 9V output battery positive was marked "+5V6" on both circuit and layout drawings in the original article. This has been mentioned in "Points Arising".

Another frequently raised point is that false signals can be produced by knocking the coil. On the prototype it takes quite a hard knock to do this, the false signal is easily recognisable as such and the continuous autotuning deals with it immediately. The cause of the signal is movement of the coil lead relative to the coil, so it can be minimised by taping the lower part of the lead to the stem to permit it as little free movement as possible.

Several constructors have complained that the meter isn't sensitive enough. This is easily cured; change R49 and R50 to 1k, D7 and D8 to OA47, and VR6 to 4k7, then set up as before. This increases the meter sensitivity by about two or three times, which on the prototype proved to be just right.

ADD-ON BOARD

Now for a rather more complex modification. Reaching for the "Mode" switch every time an object was detected proved to be something of a chore, particularly as the free hand was likely to be holding a trowel and covered with mud, wet sand or whatever. It was therefore decided to incorporate a means of changing mode from the tuning button, and a small add-on circuit board has been designed to do this. This has been in use for some time now; it makes discriminating much easier and a great deal quicker.

The circuit of this modification appears in Fig. 1. The principle of operation is simple; every time the "Tune-Hold" button is pressed a half-second timer is started. If the button is released before the timer period is complete a mode-change is initiated. Thus a quick prod of the button changes mode, but normal operation simply holds the tuning as before. Three CMOS chips are used to achieve this, two 4011s and a 4016. Two gates of the first 4011, IC1a and IC1b, are connected to form a monostable with a period of about half a second. The second two gates on this chip are unused. The output from IC1a is normally low and goes high during the timing period but so long as the button is kept pressed the output from R4 will be held low via D2. The signal for the tune-hold input on the main board is provided via D1.

The four gates of the second 4011 are connected to form a changeover switch which changes state every time its input is taken high briefly, and its complementary outputs are taken to

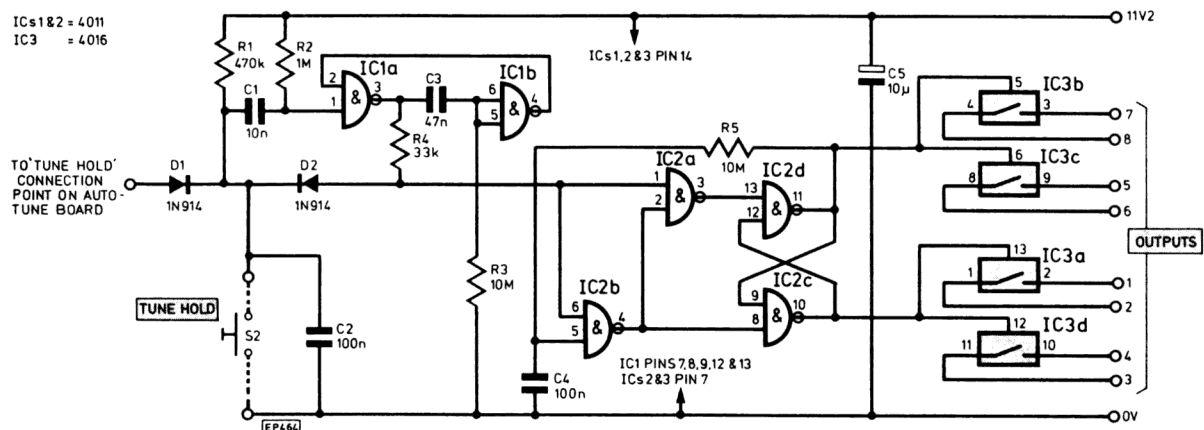

Fig. 1. Pushbutton mode change unit circuit

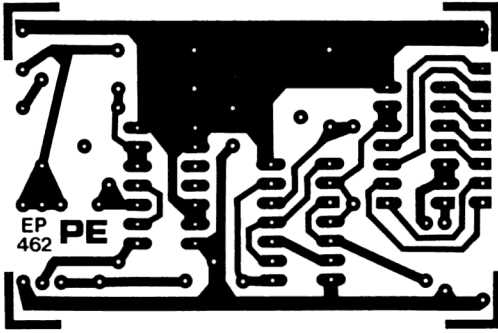

Fig. 2. Printed circuit (actual size)

the inputs of a 4016 quad switch. This gives two pairs of single-pole switches which open and close alternately, and these can be wired to provide the two changeover switches required for mode switching. Because it uses common CMOS chips this circuit is cheap to build and uses next to no additional power from the batteries.

LAYOUT

The circuit has been designed on a small p.c.b. which mounts directly onto two of the lugs in the specified Vero case, next to the meter. Fig. 3 shows the layout of the components. Construction should be straightforward providing the usual CMOS precautions are observed; there is room for sockets for the three chips. Wire tails of suitable length should be attached to the unit before it is secured into the case with a couple of self tapping screws.

Connecting the unit into the main circuit is probably the most complicated part of this modification. Fig. 4 shows how the complete circuit is changed with this unit installed; note that S1, which was a 4-pole 3-way switch, is now a 3-pole 2-way with the two positions marked "Ground" and "Beach". It may be possible to use your existing switch; many rotary switches have an adjustable stop which can be used to limit the number of positions available. Fig. 5 shows how the actual interconnections are made. Not shown are the power supplies, which are taken from the OV and +11V2 points on the power supply board, and the "Autotune" connections; button S2 connects straight into the new unit, and the single output lead from D1 goes to the old "S2" connection on the main board - the one going to TR3's gate. The other original S2 connection point is now unused.

There is, of course, no indication of which mode the unit is in when using this system. Actually this presents no problems, as when initially setting up it's in the mode whose control causes a meter deflection when moved. Once set up, there are two ways of telling. A mode-change causes an initial meter deflection before the autotune resets it; it will usually jump one way on switching to "Discrim", and the other on going back to "Ground". Also, of course, "Discrim" is the mode with the ground effect! In practice it takes no time at all to get used to the new way of changing mode and the increased speed and ease with which detected objects can be checked out should be greatly appreciated by all users.

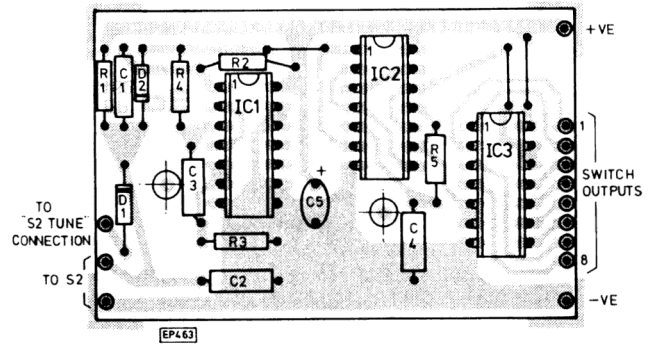

Fig. 3. Component layout

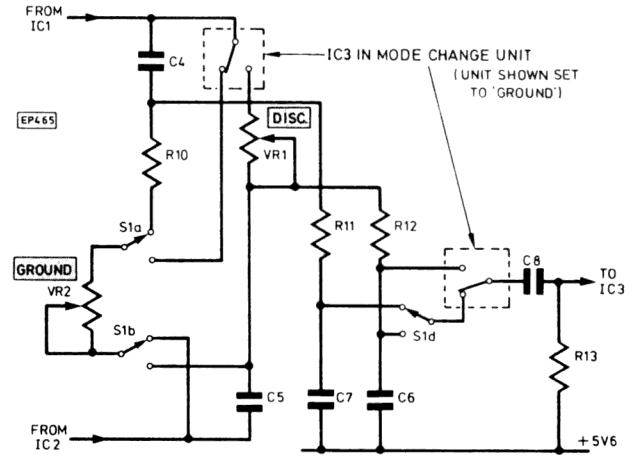

Fig. 4. Effect of adding mode change unit to main circuit

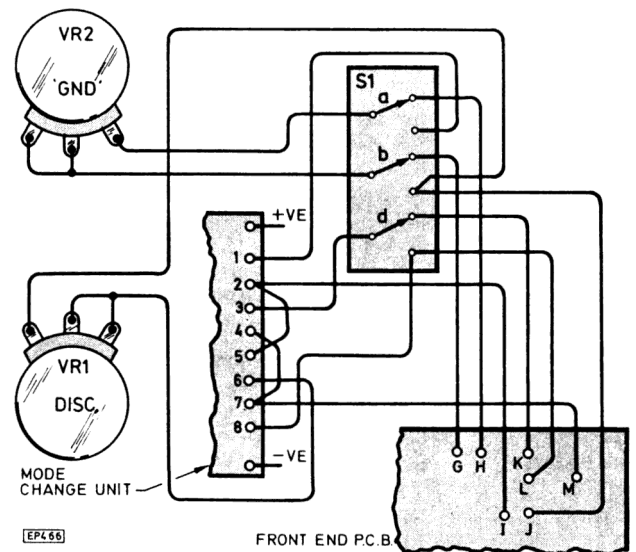

Fig. 5. Interconnections