

FM Band Monaural Transmitter

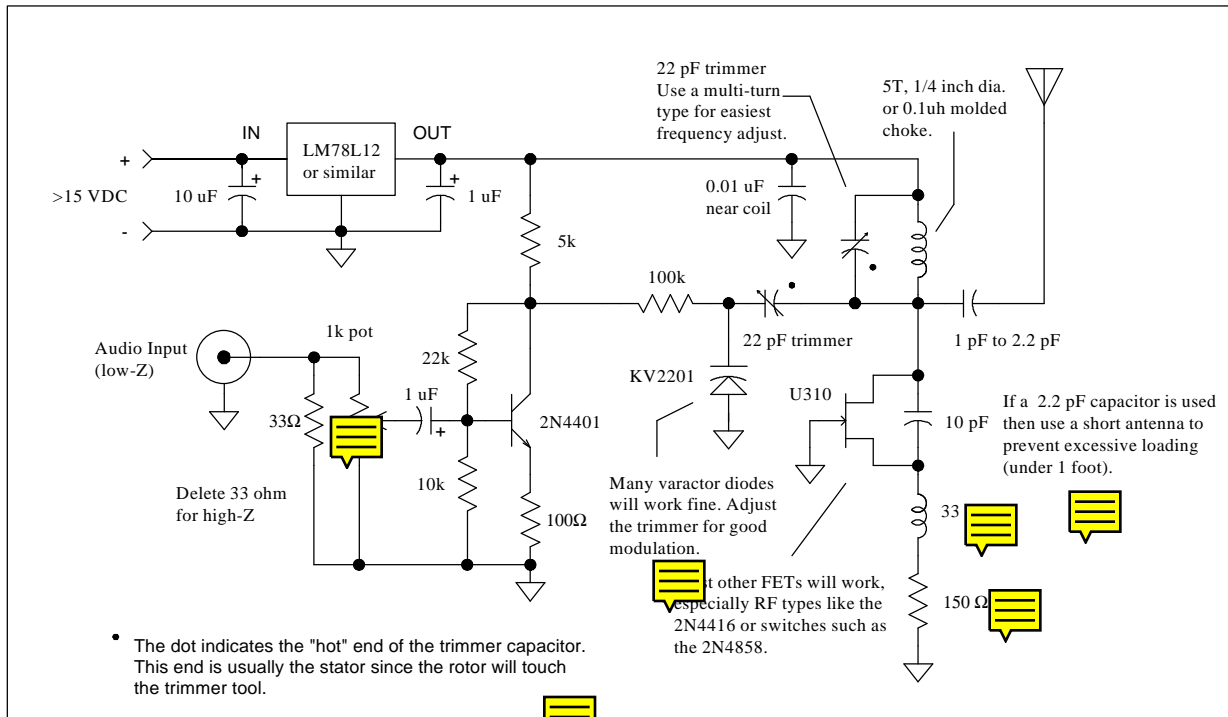

A high quality monaural FM transmitter is quite useful in a variety of applications. The audio from a TV or entertainment system may be transmitted for remote or portable listening and for wireless earphone listening. The audio from an AM receiver placed near a window can be retransmitted within a metal building where AM reception is not possible. Two transmitters will convert two portable FM receivers into cordless stereo speakers for outdoor events. A keyboard may be played through the stereo without wires simply by tuning in the transmitter. A child will love an operational, miniature FM station complete with transmit "on the air" light. Simply connect the stereo's monaural output to the transmitter and transmit CDs, tapes, microphones, and other audio sources. Connect the transmitter to the computer's sound card and have big speaker sound. Even silence may be transmitted. Tune the transmitter to your favorite station and when the annoying commercial starts, simply flip on the power and... silence (or the audio of your choice).

Ideas:

- 1) Use ground plane construction. Solder the ground connections directly to the copper circuit board material and keep the RF leads short.
- 2) Add a 680 ohm resistor in series with an LED to make an "on the air" light.
- 3) Leave the transmitter on when not in use to eliminate warm-up drift. Use a jack for the antenna so that it may be unplugged when not transmitting.
- 4) A lower voltage regulator may be used to regulate a lower voltage molded supply.
- 5) Bypass the 100 ohm resistor in the 2N4401's emitter with a 470 uF capacitor for greatly increased audio gain. Also remove the 33 ohm resistor and use a 100k pot for increased sensitivity. The entire audio stage may be replaced by an op-amp biased for V/2 volts on the output.