

Single-Chip FM Transmitter Extends Home-Entertainment Systems

Ken Yang

Maxim Integrated Products, Sunnyvale, CA

CIRCLE 522

This simple FM transmitter links your home-entertainment system to a portable radio that can be carried around the house and into the backyard (see the figure). Using this device, music playing on the CD changer in the living room can also be heard on a portable radio by the backyard barbeque.

IC1 is a voltage-controlled oscillator with integrated varactor diode. Its nominal frequency of oscillation is set by inductor L1. Using a 390-nH inductor places this frequency at 100 MHz. Potentiometer R1 allows a channel to be selected by tuning over the FM band of 88 to 108 MHz. The

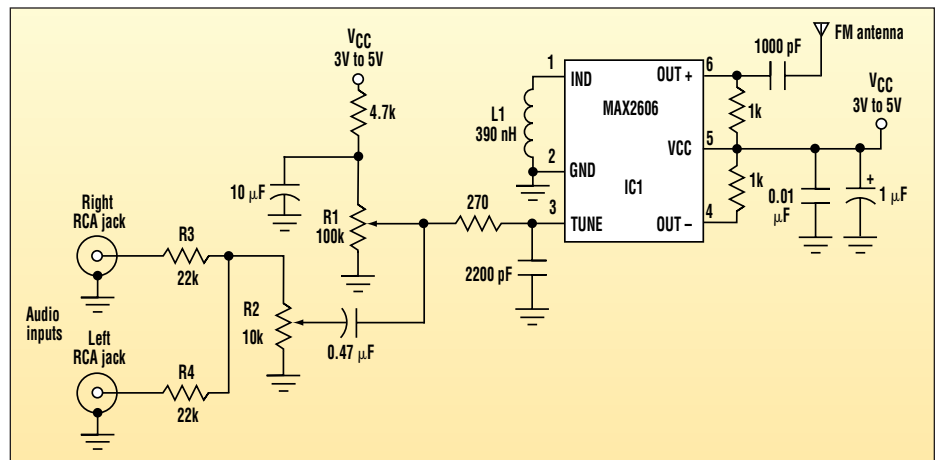

This simple, short-range FM radio transmitter can be constructed using only one IC.

IDEAS FOR DESIGN

output power is about -21 dBm into $50\ \Omega$ (most countries accept emissions below 10 dBm in the FM band).

Summed by R3 and R4, the home system's left and right audio signals are attenuated by the optional potentiometer R2. R2's wiper signal serves as

a volume control by modulating the RF signal. Signals above 60 mV can introduce distortion, so the pot attenuates down from this level.

In the absence of a standard FM radio antenna, 75 cm of wire will suffice as a receiving antenna. For best reception,

the receive antenna should be mounted parallel to the transmitting antenna. The IC operates on a single supply voltage in the range of 3 to 5 V. It's recommended, however, that the applied voltage be regulated to minimize frequency drift and noise. ◻
