



# CML Semiconductor Products

## Calling Line Identifier

# FX602

D/602/5 April 1996

Provisional Information

### 1.0 Features

- CLI and CIDCW Detector with:
  - On-Hook and Off-Hook Operation
  - 'Zero-Power' Ring or Line Polarity Reversal Detector
  - V23/Bell202 FSK Demodulator with Data Retiming facility
  - Dual-Tone Alert Detector
  - Low Voltage Operation
  - For Bellcore, ETSI, British Telecom and Mercury Systems
  - $\mu$ C Interrupt/Wake-up output to minimise system operating power
  - 16-pin SOIC and DIL packages

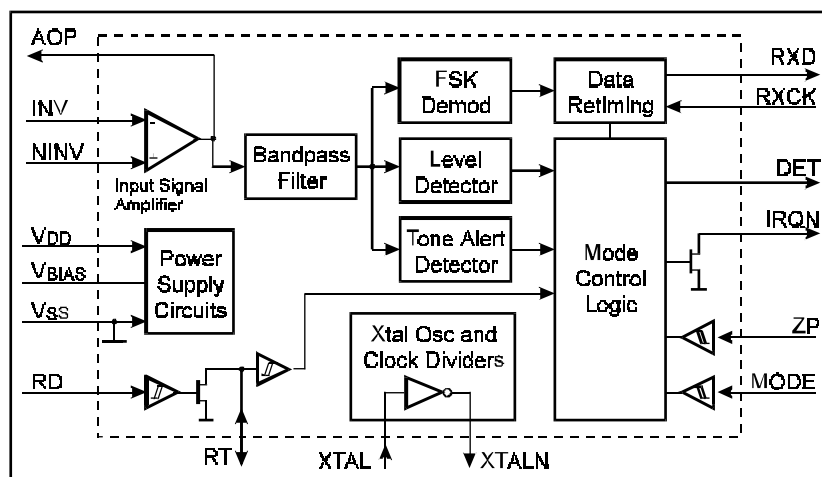

### 1.1 Brief Description

The FX602 is a low power CMOS integrated circuit for the reception of the physical layer signals used in BT's Calling Line Identification Service (CLIP), Bellcore's Calling Identity Delivery system (CID), the Cable Communications Association's Caller Display Services (CDS), and similar evolving services. It also meets the requirements of emerging Caller Identity with Call Waiting services.

The device includes a 'zero-power' ring or line polarity reversal detector, a dual-tone (2130Hz plus 2750Hz) Tone Alert Signal detector and a 1200-baud FSK V23/Bell202 compatible asynchronous data demodulator with a data retiming circuit which removes the need for a UART in the associated  $\mu$ C.

It is suitable for use in systems to BT specifications SIN227 and SIN242, Bellcore TR-NWT-000030 and SR-TSV-002476, CCA TW/P&E/312, ETSI ETS 300 659 parts 1 and 2, and Mercury Communications MNR 19.

**CONTENTS**

<u>Section</u>	<u>Page</u>
<b>1.0 Features .....</b>	<b>1</b>
<b>1.1 Brief Description .....</b>	<b>1</b>
<b>1.2 Block Diagram .....</b>	<b>3</b>
<b>1.3 Signal List .....</b>	<b>4</b>
<b>1.4 External Components .....</b>	<b>6</b>
<b>1.5 General Description .....</b>	<b>7</b>
1.5.1 Mode Control Logic .....	7
1.5.2 Input Signal Amplifier .....	7
1.5.3 Bandpass Filter .....	8
1.5.4 Level Detector .....	8
1.5.5 FSK Demodulator .....	9
1.5.6 FSK Data Retiming .....	9
1.5.7 Tone Alert Detector .....	10
1.5.8 Ring or Line Polarity Reversal Detector .....	11
1.5.9 Xtal Osc and Clock Dividers .....	13
<b>1.6 Application Notes .....</b>	<b>14</b>
1.6.1 'On-Hook' Operation .....	14
1.6.2 'Off-Hook' Operation .....	15
<b>1.7 Performance Specification .....</b>	<b>24</b>
1.7.1 Electrical Performance .....	24
1.7.2 Packaging .....	28

## 1.2 Block Diagram

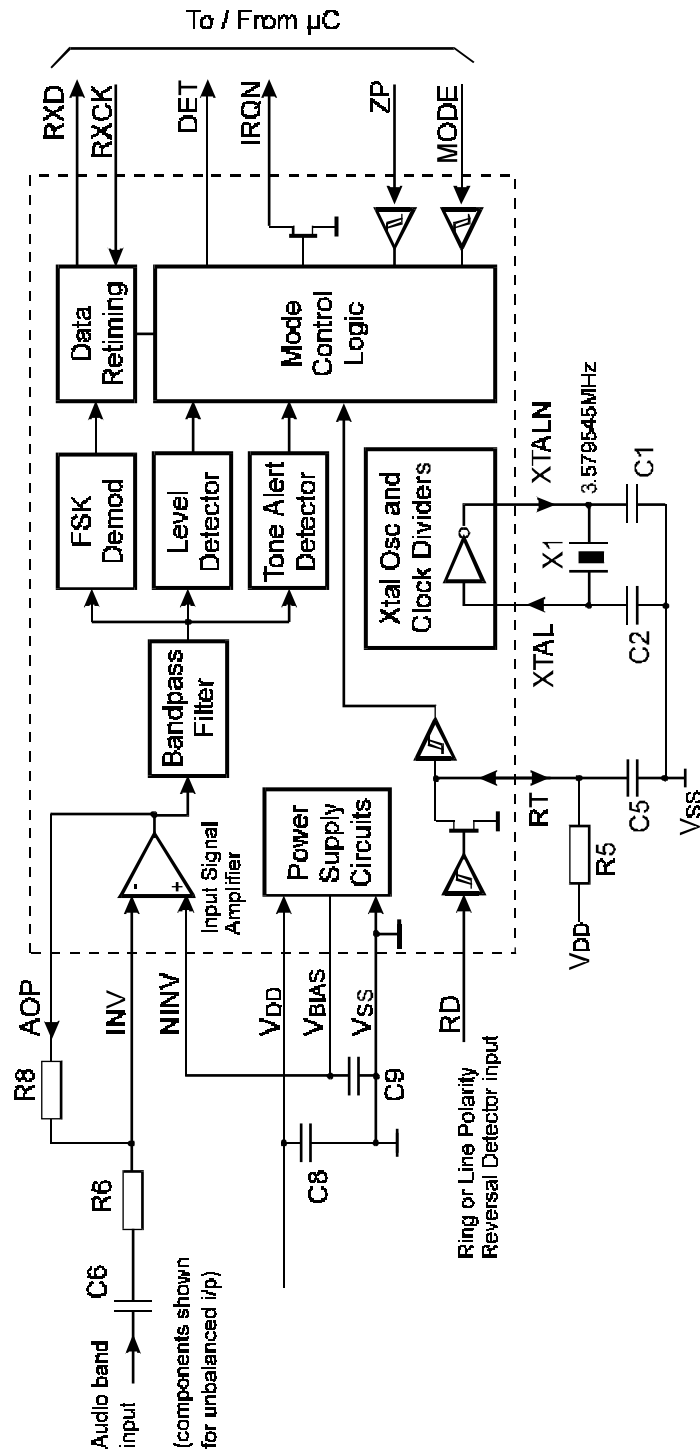

Figure 1 Block Diagram

### 1.3 Signal List

Packages D4 / P3	Signal		Description
Pin No.	Name	Type	
1	XTALN	O/P	The output of the on-chip Xtal oscillator inverter.
2	XTAL	I/P	The input to the on-chip Xtal oscillator inverter.
3	RD	I/P (S)	Input to the Ring or Line Polarity Reversal Detector.
4	RT	BI	Open-drain output and Schmitt trigger input forming part of the Ring or Line Polarity Reversal detector. An external resistor to $V_{DD}$ and a capacitor to $V_{SS}$ should be connected to RT to filter and extend the RD input signal.
5	AOP	BI	The output of the on-chip Input Signal Amplifier and the input to the Bandpass Filter.
6	INV	I/P	The inverting input to the on-chip Input Signal Amplifier.
7	NINV	I/P	The non-inverting input to the on-chip Input Signal Amplifier.
8	$V_{SS}$	Power	Negative supply rail (signal ground).
9	$V_{BIAS}$	O/P	Internally generated bias voltage, held at $V_{DD}/2$ when the device is not in 'Zero-Power' mode. Should be decoupled to $V_{SS}$ by a capacitor mounted close to the device pins.
10	MODE	I/P (S)	Input used to select the operating mode. See section 1.5.1.
11	ZP	I/P (S)	A high level on this input selects 'Zero-Power' mode, a low level enables the Input Signal Amplifier, the Bandpass Filter and either the FSK or the Tone Alert circuits depending on the MODE input.

Packages D4 / P3	Signal		Description
Pin No.	Name	Type	
12	IRQN	O/P	An open-drain active low output that may be used as an Interrupt Request / Wake-up input to the associated $\mu$ C. An external pull-up resistor should be connected between this output and $V_{DD}$ .
13	DET	O/P	A logic level output driven by the Ring or Line Polarity Reversal Detector, the Tone Alert Detector or the FSK Level detect circuits, depending on the operating mode. See section 1.5.1.
14	RXCK	I/P	A logic level input which may be used to clock received data bits out of the FSK Data Retiming block.
15	RXD	O/P	A logic level output carrying either the raw output of the FSK Demodulator or re-timed 8-bit characters depending on the state of the RXCK input. See section 1.5.6
16	$V_{DD}$	Power	The positive supply rail. Levels and thresholds within the device are proportional to this voltage. Should be decoupled to $V_{SS}$ by a capacitor mounted close to the device pins.

**Notes:** I/P = Input  
I/P (S) = Schmitt trigger input  
O/P = Output  
BI = Bidirectional

### 1.4 External Components

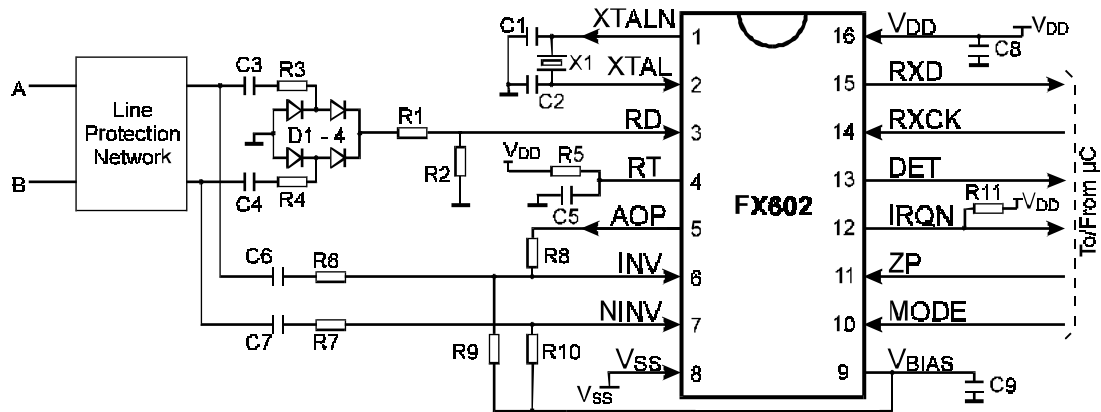

R1	470kΩ	C1, C2	18pF
R2	See section 1.5.8	C3, C4	0.1µF
R3, R4, R5	470kΩ	C5	0.33µF
R6, R7	470kΩ	C6, C7	680pF
R8	470kΩ for V <sub>DD</sub> = 3.3V 680kΩ for V <sub>DD</sub> = 5.0V (See section 1.5.2)	C8, C9	0.1µF
R9	240kΩ for V <sub>DD</sub> = 3.3V 200kΩ for V <sub>DD</sub> = 5.0V (See section 1.5.2)		
R10	160kΩ	X1	3.579545MHz
R11	100kΩ ±20%	D1 - D4	1N4004

Resistors ±1%, capacitors ±20% unless otherwise stated.

**Figure 2 Recommended External Components for Typical Application**

## 1.5 General Description

### 1.5.1 Mode Control Logic

The FX602's operating mode and the source of the DET and IRQN outputs are determined by the logic levels applied to the MODE and ZP input pins;

ZP	MODE	Mode	DET o/p from	IRQN o/p from
0	0	Tone Alert Detect	Tone Alert Signal Detection	End of Tone Alert Signal. Ring or Line Polarity Reversal Detector.
0	1	FSK Receive	FSK Level Detector	FSK Data Retiming [1]. Ring or Line Polarity Reversal Detector.
1	0	'Zero-Power'	Ring or Line Polarity Reversal Detector.	Ring or Line Polarity Reversal Detector.
1	1	'Zero-Power'	Ring or Line Polarity Reversal Detector.	-

[1] If enabled.

In the 'Zero-Power' modes, power is removed from all of the internal circuitry except for the Ring or Line Polarity Reversal Detector and the DET and IRQN outputs.

### 1.5.2 Input Signal Amplifier

This amplifier is used to convert the balanced FSK and Tone Alert signals received over the telephone line to an unbalanced signal of the correct amplitude for the FSK receiver and Tone Alert Detector circuits.

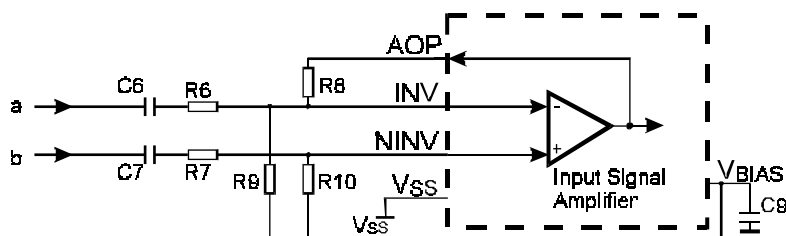

Figure 3a : Input Signal Amplifier, balanced input configuration

The design equations for this circuit are;

$$\begin{aligned} \text{Differential voltage gain } V_{AOP} / V(b-a) &= R8/R6 \\ R6 &= R7 = 470\text{k}\Omega \\ R10 &= 160\text{k}\Omega \\ R9 &= R8 \times R10 / (R8 - R10) \end{aligned}$$

The target differential voltage gain depends on the expected signal levels between the A and B wires and the FX602's internal threshold levels, which are proportional to the supply voltage.

The FX602 has been designed to meet the applicable specifications with  $R8 = 470\text{k}\Omega$  at  $V_{DD} = 3.3\text{V}$  nominal, rising to  $680\text{k}\Omega$  at  $V_{DD} = 5.0\text{V}$ , and  $R9$  should be  $240\text{k}\Omega$  at  $V_{DD} = 3.3\text{V}$  and  $200\text{k}\Omega$  at  $V_{DD} = 5.0\text{V}$  as shown in section 1.4 and Fig 3c.

The Input Signal Amplifier may also be used with an unbalanced signal source as shown in Figure 3b. The values of R6 and R8 are as for the balanced input case.

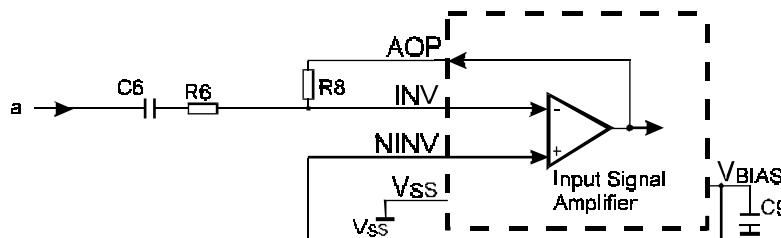

Figure 3b : Input Signal Amplifier, unbalanced input configuration

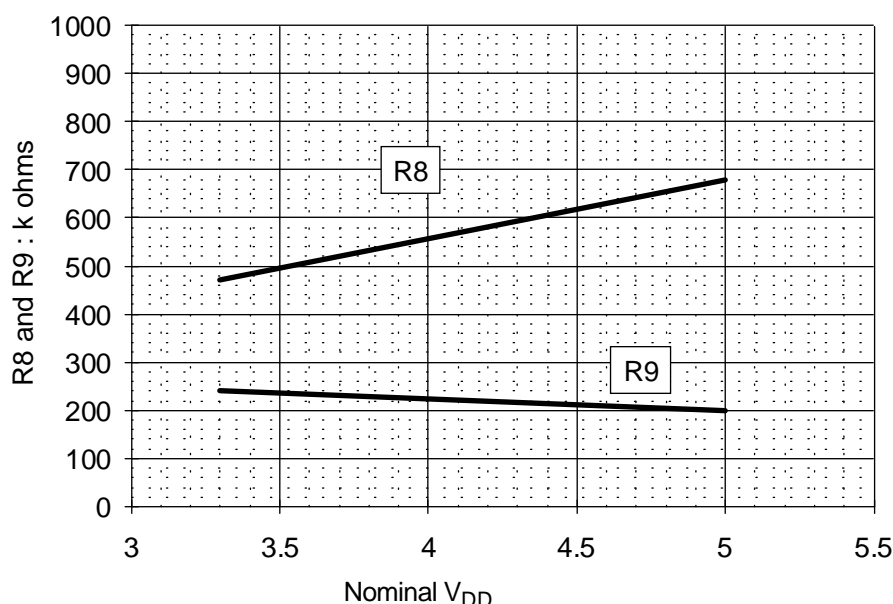

Figure 3c : Input Signal Amplifier, optimum values of R8 and R9 vs  $V_{DD}$

### 1.5.3 Bandpass Filter

Is used to attenuate out of band noise and interfering signals which might otherwise reach the FSK Demodulator, Tone Alert Detector and Level Detector circuits. The characteristics of this filter differ in FSK and Tone Alert modes. Most of the filtering is provided by Switched Capacitor stages clocked at 57.7kHz.

### 1.5.4 Level Detector

This block operates by measuring the level of the signal at the output of the Bandpass Filter, and comparing it against a threshold which depends on whether FSK Receive or Tone Alert Detect mode has been selected.

In Tone Alert Detect mode the output of the Level Detector block provides an input to the Tone Alert Signal Detector.



In FSK Receive mode the FX602 DET output will be set high when the level has exceeded the threshold for sufficient time. Amplitude and time hysteresis are used to reduce chattering of the DET output in marginal conditions.

Note that in FSK Receive mode this circuit may also respond to non-FSK signals such as speech.

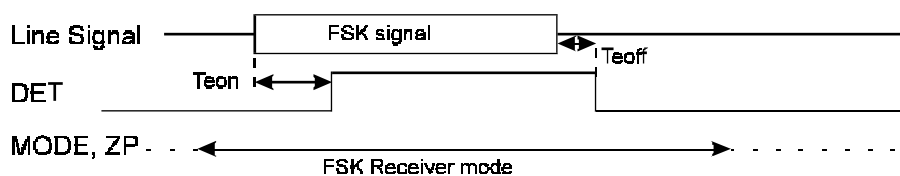

See section 1.7.1 for definitions of Teon and Teoff

**Figure 4 : FSK Level Detector operation**

### 1.5.5 FSK Demodulator

This block converts the 1200 baud FSK input signal to a logic level received data signal which is output via the RXD pin as long as the Data Retiming function is not enabled (see section 1.5.6). This output does not depend on the state of the FSK Level Detector output.

Note that in the absence of a valid FSK signal, the demodulator may falsely interpret speech or other extraneous signals as data.

### 1.5.6 FSK Data Retiming

The Data Retiming block extracts the 8 data bits of each character from the received asynchronous data stream, and presents them to the  $\mu\text{C}$  under the control of strobe pulses applied to the RXCK input. The timing of these pulses is not critical and they may easily be generated by a simple software loop. This facility removes the need for a UART in the  $\mu\text{C}$  without incurring an excessive software overhead.

The block operates on a character by character basis by first looking for the mark to space transition which signals the beginning of the start bit, then, using this as a timing reference, sampling the output of the FSK Demodulator in the middle of each of the following 8 received data bits, storing the results in an internal 8-bit shift register.

When the eighth data bit has been clocked into the internal shift register, the FX602 examines the RXCK input. If this is low then the IRQN output will be pulled low and the first of the stored data bits put onto the RXD output pin. On detecting that the IRQN output has gone low, the  $\mu\text{C}$  should pulse the RXCK pin high 8 times. The high to low transition at the end of the first 7 of these pulses will be used by the FX602 to shift the next data bit from the shift register onto the RXD output. At the end of the eighth pulse the FSK Demodulator output will be reconnected to the RXD output pin. The IRQN output will be cleared the first time the RXCK input goes high.

Thus to use the Data Retiming function, the RXCK input should be kept low until the IRQN output goes low; if the Data Retiming function is not required the RXCK input should be kept high.

The only restrictions on the timing of the RXCK waveform are those shown in Figure 5a and the need to complete the transfer of all eight bits into the  $\mu\text{C}$  within 8.3mSec (the time of a complete character at 1200 baud).

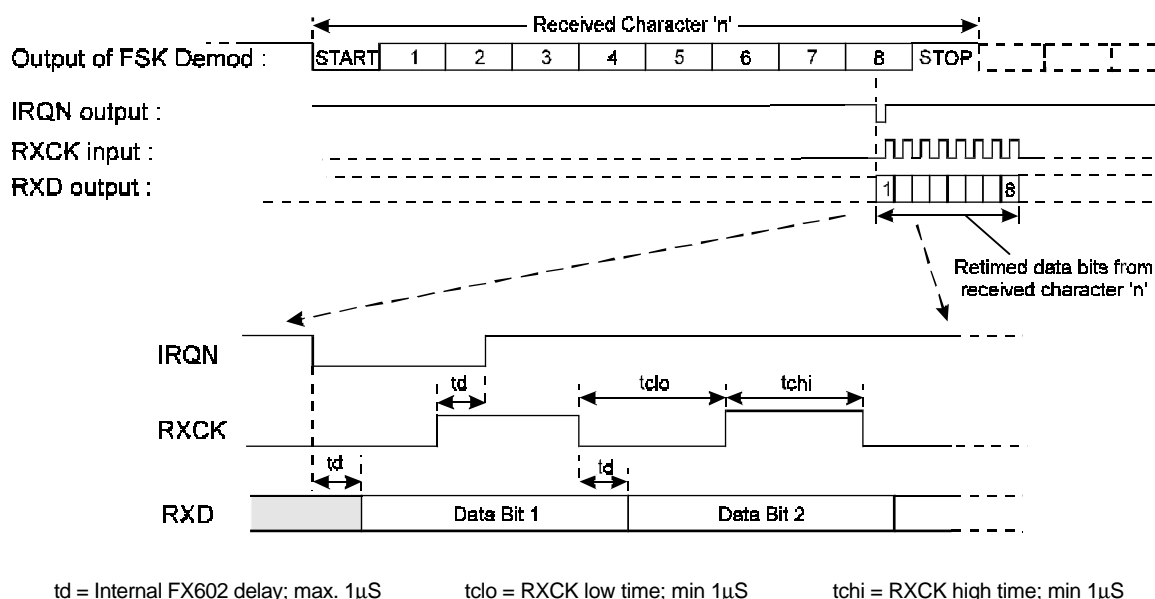

**Figure 5a : FSK Operation With Data Retiming**

Note that, if enabled, the Data Retiming block will interpret the FSK Channel Seizure signal (a sequence of alternating mark and space bits) as valid received characters, with values of 55 (hex). Similarly it may interpret speech or other signals as random characters.

If the Data Retiming facility is not required, the RXCK input to the FX602 should be kept high. The asynchronous data from the FSK Demodulator will then be connected directly to the RXD output pin, and the IRQN output will not be activated by the FSK signal. This case is illustrated in Figure 5b.

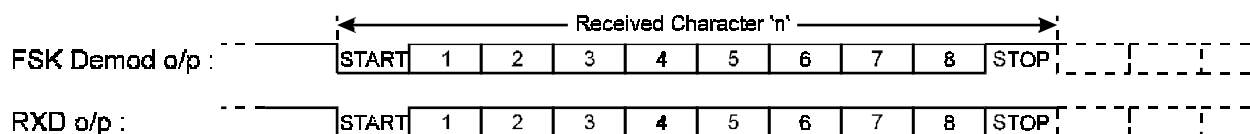
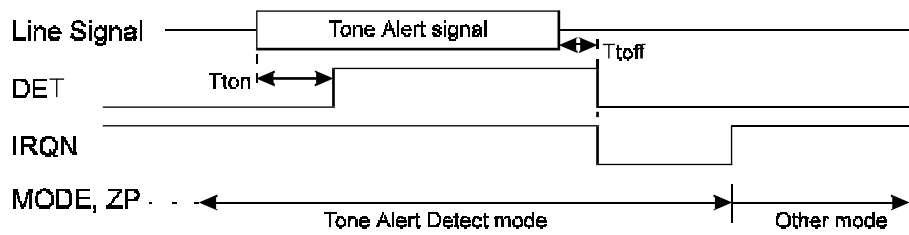

**Figure 5b : FSK Operation Without Data Retiming (RXCK always high)**

### 1.5.7 Tone Alert Detector

This block is enabled when the FX602 is set to Tone Alert Detector operating mode. It will then monitor the received signal for the presence of simultaneous 2130 and 2750Hz tones of sufficient level and duration.

The FX602 DET output will be set high while a valid Tone Alert signal is detected. At the end of the Tone Alert signal the DET output will go low and the IRQN output will be pulled low until the FX602 is switched out of Tone Alert Detector mode.



See section 1.7.1 for definitions of Tton and Ttoff

Figure 6 : Tone Alert Detector operation

### 1.5.8 Ring or Line Polarity Reversal Detector

These circuits are used to detect the Line Polarity Reversal and Ringing signals associated with the Calling Line Identification protocol.

Figure 7 illustrates their use in a typical application.

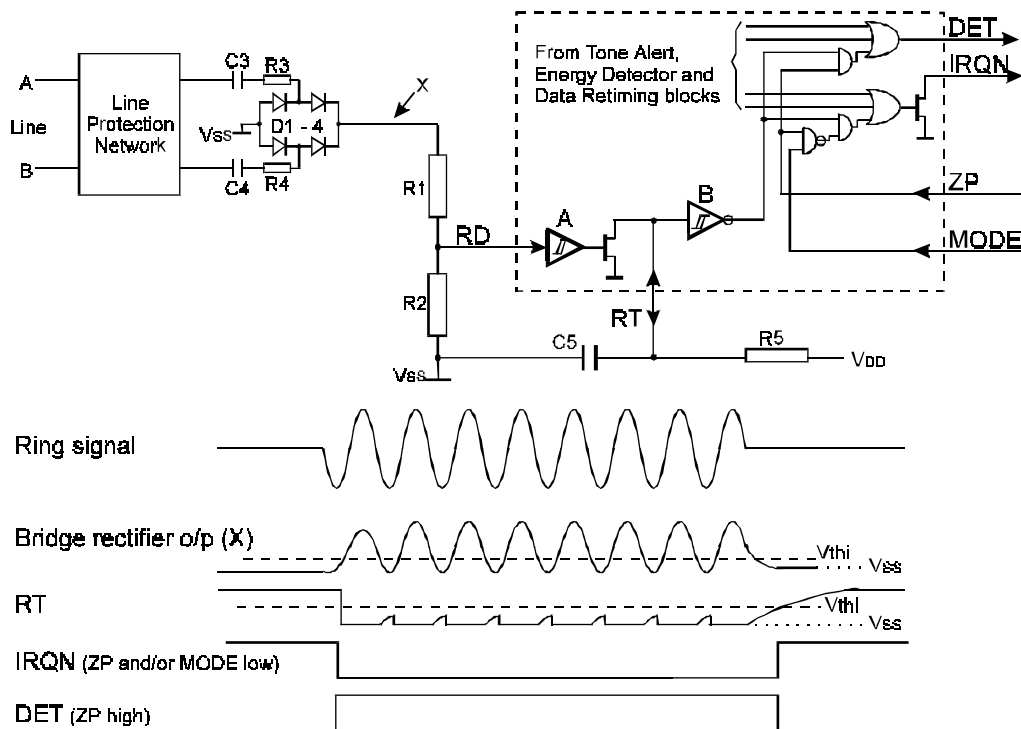

Figure 7 : Ring or Line Polarity Reversal operation

When no signal is present on the telephone line, RD will be at  $V_{SS}$  and RT pulled to  $V_{DD}$  by R5 so the output of the Schmitt trigger 'B' will be low.

The ring signal is usually applied at the subscriber's exchange as an ac voltage inserted in series with one of the telephone wires and will pass through either C3 and R3 or C4 and R4 to appear at the top end of R1 (point X in Figure 7) in a rectified and attenuated form.

The signal at point X will be further attenuated by the potential divider formed by R1 and R2 before being applied to the FX602 input RD. If the amplitude of the signal appearing at RD is greater than the input threshold ( $V_{thi}$ ) of Schmitt trigger 'A' then the N transistor connected to RT will be turned on, pulling the voltage at RT to  $V_{SS}$  by discharging the external capacitor C5. The output of the Schmitt trigger 'B' will then go high, activating the DET and/or IRQN outputs depending on the states of the MODE and ZP inputs.

The minimum amplitude ringing signal that is certain to be detected is

$$(0.7 + V_{thi} \times [R1 + R2 + R3] / R2) \times 0.707 \text{ V}_{rms}$$

where  $V_{thi}$  is the high-going threshold voltage of the Schmitt trigger A (see section 1.7).

With R1, R3 and R4 all  $470k\Omega$  as Figure 2, then setting R2 to  $68k\Omega$  will guarantee detection of ringing signals of  $40V_{rms}$  and above for  $V_{DD}$  over the range 3.0 to 5.5V.

A line polarity reversal may be detected using the same circuit but there will be only one pulse at RD. The BT specification SIN242 says that the circuit must detect a +15V to -15V reversal between the two lines slewing in 30msec. For a linearly changing voltage at the input to C3 (or C4), then the voltage appearing at the RD pin will be

$$dV/dt \times C3 \times [1 - \exp(-t/T)] \times R2$$

where  $T = C3 \times (R1 + R2 + R3)$  and  $dV/dt$  is the input slew rate.

For  $dV/dt = 500V/sec$  (15V in 30msec), R1, R3 and R4 all  $470k\Omega$  and C3, C4 both  $0.1\mu F$  as Figure 2, then setting R2 to  $390k\Omega$  will guarantee detection at  $V_{DD} = 5.5V$ .

If the time constant of R5 and C5 is large enough then the voltage on RT will remain below the threshold of the 'B' Schmitt trigger keeping the DET and/or IRQN outputs active for the duration of a ring cycle. The time for the voltage on RT to charge from  $V_{SS}$  towards  $V_{DD}$  can be derived from the formula

$$V_{RT} = V_{DD} \times [1 - \exp(-t/(R5 \times C5))] ]$$

As the Schmitt trigger high-going input threshold voltage ( $V_{thi}$ ) has a minimum value of  $0.56 \times V_{DD}$ , then the Schmitt trigger B output will remain high for a time of at least  $0.821 \times R5 \times C5$  following a pulse at RD.

Using the values given in Figure 2 ( $470k\Omega$  and  $0.33\mu F$ ) gives a minimum time of 100 msec (independent of  $V_{DD}$ ), which is adequate for ring frequencies of 10Hz or above.

If necessary, the  $\mu C$  can distinguish between a ring and a reversal by timing the length of the IRQN or DET output.

### 1.5.9 Xtal Osc and Clock Dividers

Frequency and timing accuracy of the FX602 is determined by a 3.579545MHz clock present at the XTAL pin. This may be generated by the on-chip oscillator inverter using the external components C1, C2 and X1 of Figure 2, or may be supplied from an external source to the XTAL input, in which case C1, C2 and X1 should not be fitted.

The oscillator is turned off in the 'Zero-Power' modes.

If the clock is provided by an external source which is not always running, then the ZP input must be set high when the clock is not available. Failure to observe this rule may cause a significant rise in the supply current drawn by FX602 as well as generating undefined states of the RXD, DET and IRQN outputs.

## 1.6 Application Notes

### 1.6.1 'On-Hook' Operation

Figures 8a to 8c below illustrate the line signalling and FX602 I/O signals for typical 'On-Hook' (Calling Line ID) BT and Bellcore system use.

The BT Tone Alert signal consists of simultaneous 2130Hz and 2750Hz tones. The 'Chan Seize' signal consists of a '1010..' FSK bit sequence in all cases.

Note that the Data Retiming function is not used in these examples (RXCK is kept high).

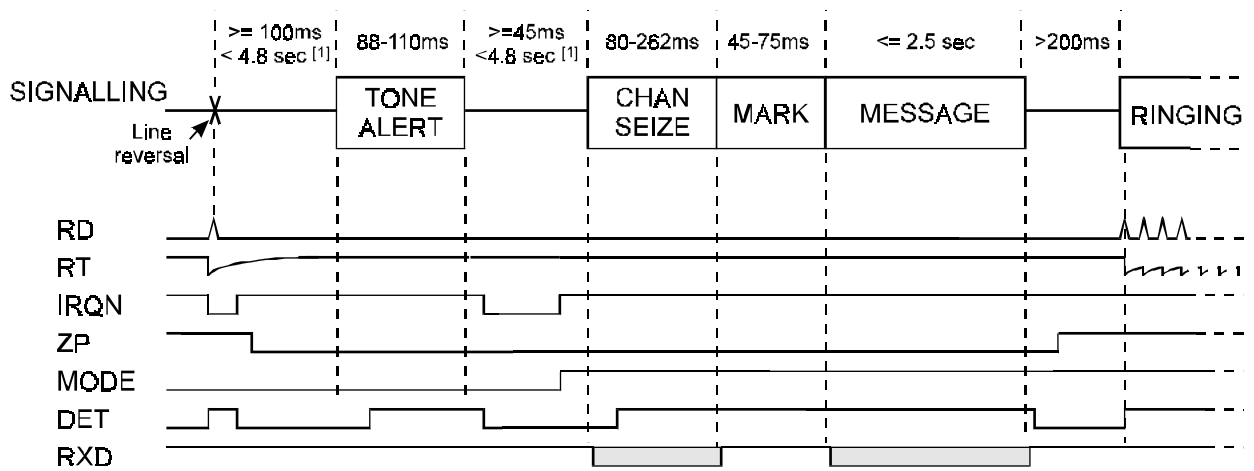

[1] Sum of these two periods does not exceed 5 sec

Figure 8a : BT System signals

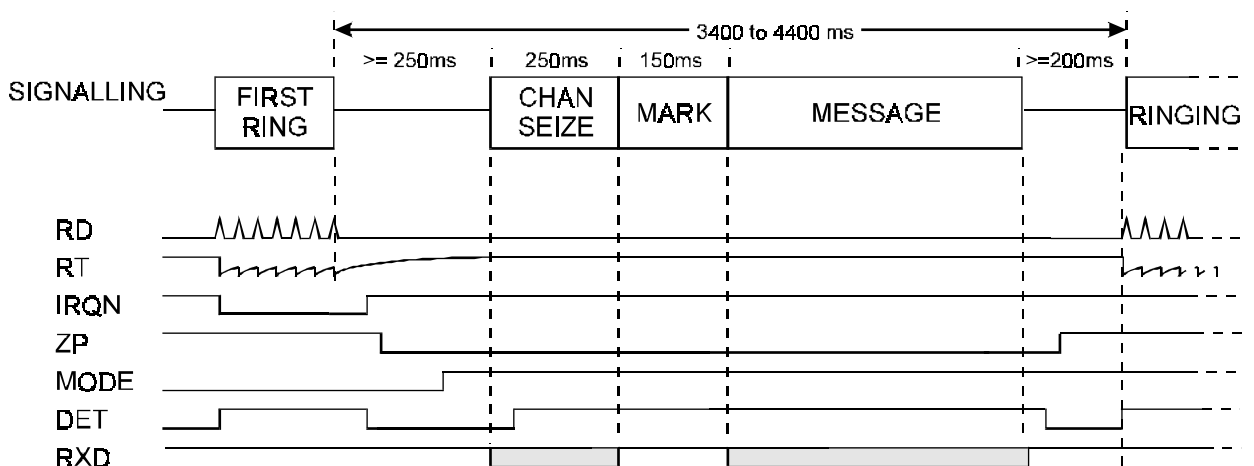

Figure 8b : Bellcore System signals

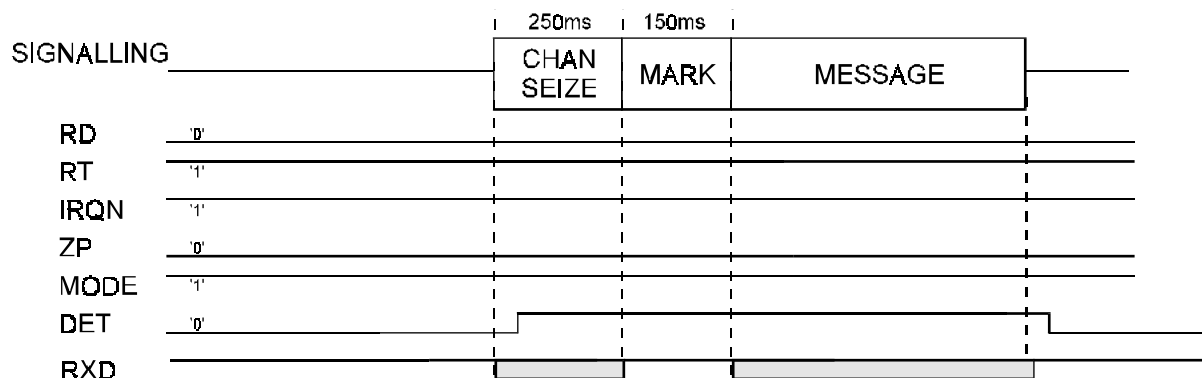

Figure 8c : Bellcore System signals (without ring)

### 1.6.2 'Off-Hook' Operation

#### Introduction

CIDCW (Calling Identity on Call Waiting) is a telephone service which identifies a waiting caller without interrupting your current call. It eliminates the 'blind spot' in traditional Call Waiting by giving a telephone user the informed choice of whether or not to take the incoming call.

To support CIDCW, the circuits of Caller ID compatible telephone equipment and adjunct 'boxes' must detect a subtle CPE Alert Signal (CAS), injected into phone conversations. The CAS is transmitted by the Central Office to initiate a CIDCW transaction and consists of a 80ms burst of simultaneous 2130Hz and 2750Hz tones.

CAS detection accuracy is very important because both missed and false signal detection is evident and annoying to telephone users. Missed signal detection causes Caller ID information to be lost, false signal detection produces a disruptive tone which is heard by the far end caller. Because the CAS signals must be detected in the presence of conversations which both mask and masquerade as the tone signals, this function is very difficult to accomplish correctly.

This application note describes the use of the FX602 for accurate CAS detection, providing better CIDCW performance than other solutions. The FX602's <1µA ring detect supply current, 3 to 5 volt supply range, and 16 pin package also offer significant advantages in battery life and final product size.

#### Overview

A successful CIDCW transaction as described in Bellcore SR-TSV-002476 consists of a sequence of actions between the CPE (Customer Premises Equipment - e.g. a telephone) and the Central Office as indicated in Figure 9a.

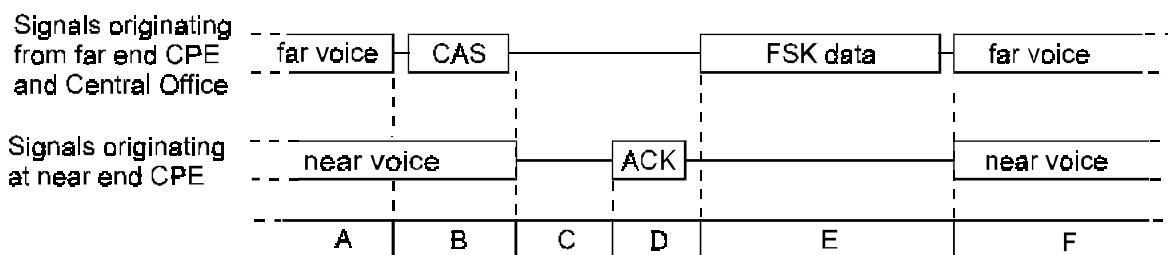

- A. Normal conversation with both near and far end voice present.
- B. Central Office mutes far end voice, sends CAS and becomes silent.
- C. CPE recognises CIDCW initiation and mutes near end voice and keypad.
- D. CPE sends dtmf ACK to Central Office to signal its readiness to receive FSK data.
- E. Central Office recognises ACK and sends FSK Caller ID data to CPE.
- F. CIDCW transaction is complete. CPE unmutes near end voice and the Central Office unmutes far end voice, returning to normal conversation.

**Figure 9a : CIDCW Transaction from Near End CPE Perspective**

From the near end CPE's perspective, the initiation of a CIDCW transaction is characterized by two events occurring in sequence: (1) a CAS dual tone burst is received, and (2) a subsequent quiet period passes as far end speech continues to be muted. In the algorithm to be described these two events are detected by the FX602's Dual Tone Alert detector and FSK level detector, respectively.

Caller ID and CIDCW products require a microcontroller to manage the transfer and display of Caller ID data. The same microcontroller is easily used to observe and control the FX602 CIDCW transaction initiation detection process. This involves measuring the FX602 DET output pulse duration, controlling the muting of near end voice, watching for further DET output activity, and controlling whether the FX602 is in Dual Tone Alert or FSK Receive modes, as shown in Figure 9b below.

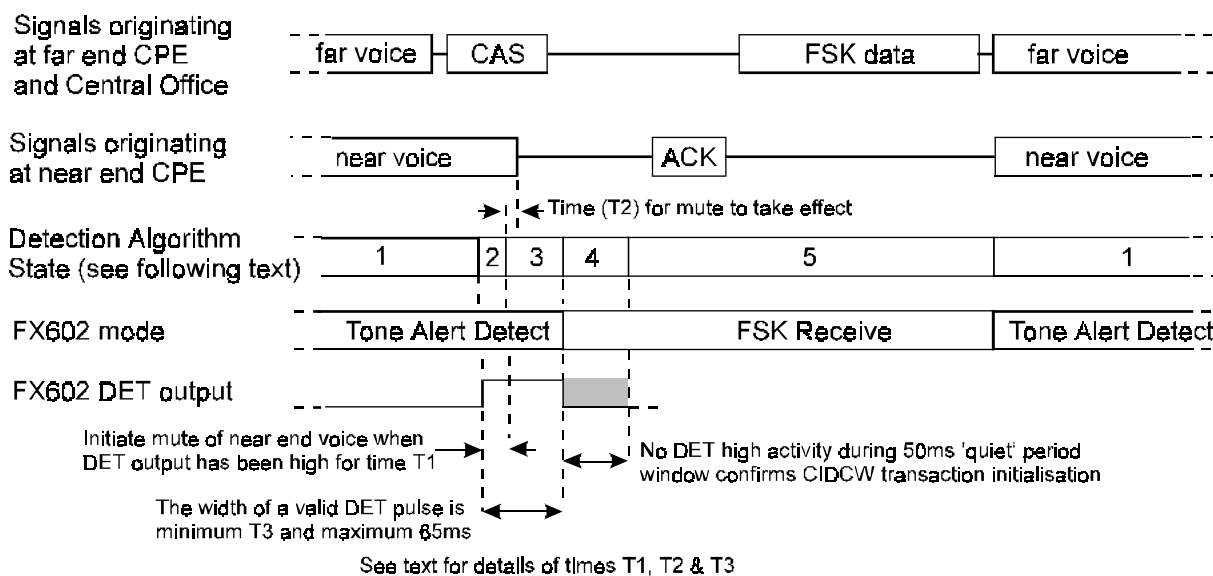
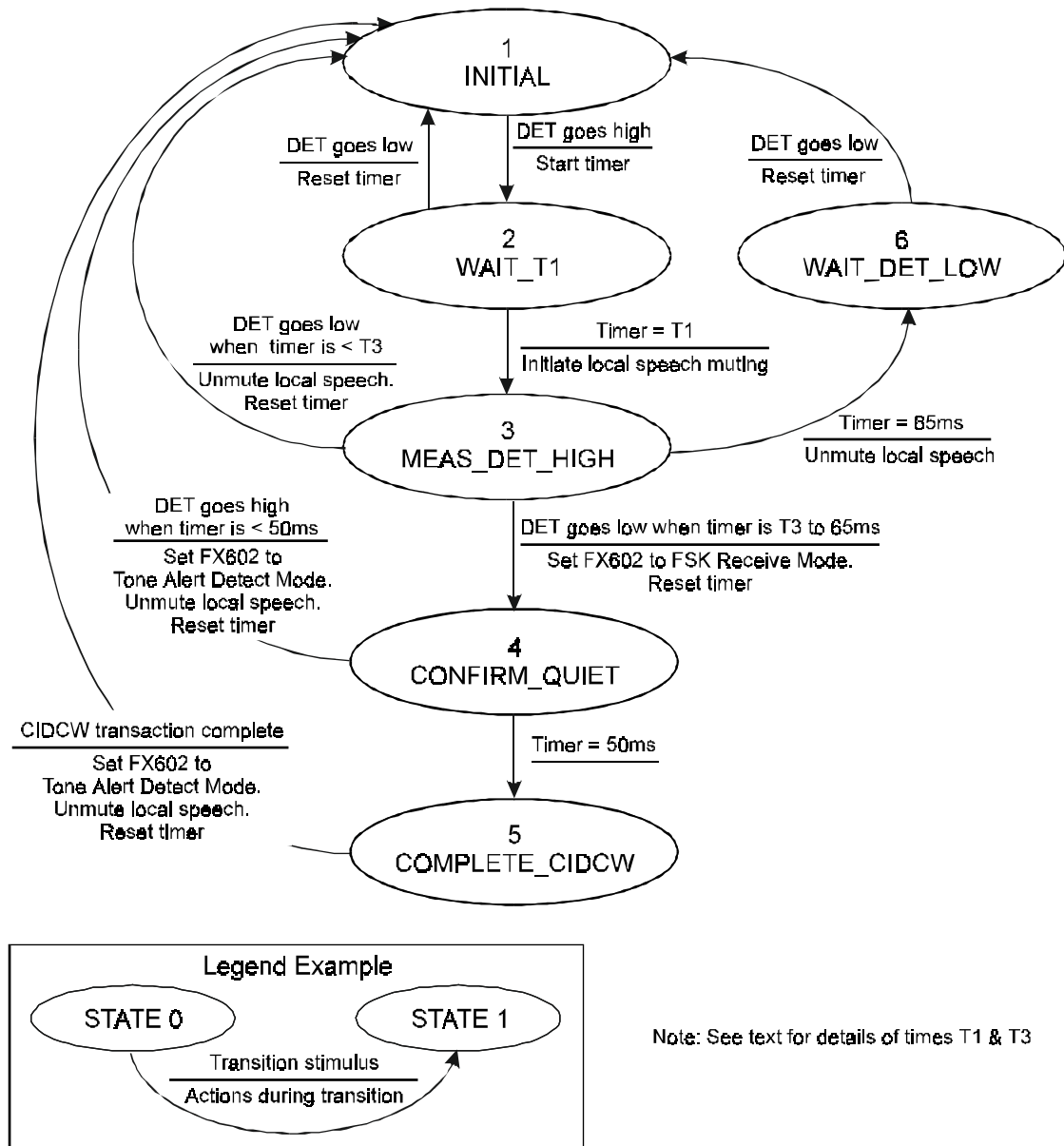

**Figure 9b : FX602 Operation during CIDCW Transaction**



### CIDCW Transaction Initiation Detection Algorithm

The following State Transition Diagram, (Figure 9c) and explanatory text provide a detailed description of the CIDCW detection procedure shown in Figure 9b.



**Figure 9c : FX602 Based CIDCW Transaction State Transition Diagram**

## 1. INITIAL state

This is the normal state when the CPE is off hook. The FX602 is in the Tone Alert Detect mode, the timer is reset and the FX602's DET output line is being monitored.

If the FX602 DET output goes high start the timer, and go to the WAIT\_T1 state.

## 2. WAIT\_T1 state

During this state the DET output high time is measured so that pulses lasting less than time T1 may be ignored.

If the DET output goes low before time T1 then reset the timer and return to the INITIAL state.

If the DET output is still high when the timer reaches time T1 then initiate muting of the local speech circuit and go to the MEAS\_DET\_HI state. Muting should be complete within time T2.

## 3. MEAS\_DET\_HIGH state

This state continues to measure the length of the FX602 DET output high pulse, but now the local speech is muted to eliminate any false CAS signals it may generate.

If the DET output goes low before time T3 then the signal was most probably due to near end speech, so cancel the speech muting, reset the timer and return to the INITIAL state.

If the DET output is still high when timer reaches 65ms the signal is too long to be a valid CAS and must have been caused by far end speech, so cancel the speech muting and go to the WAIT\_DET\_LOW state.

If the DET output goes low when the timer is between T3 and 65ms then it could be a valid CAS, in which case it will be followed by a 'quiet' period (local speech being muted) so set the FX602 to FSK Receive mode, reset the timer and go to the CONFIRM\_QUIET state. These actions should take place within 5ms of the DET output going low.

## 4. CONFIRM\_QUIET state

During this state the energy present at the FX602's input after the end of the dual-tone detection is monitored for up to 50ms using the FX602's FSK Level Detector circuits. If the received signal had been a valid CAS then it would have been followed by a quiet period (the local speech being muted by this algorithm) whereas a false signal caused by far end speech will contain additional energy in the following period.

If the DET output goes high before the timer has reached 50ms then remove local speech muting, set the FX602 to Tone Alert Detect mode and return to the INITIAL state.

If the timer reaches 50ms then a valid CAS has been detected so go to the COMPLETE\_CIDCW state.

## 5. COMPLETE\_CIDCW state

This state handles the remaining CIDCW transaction functions e.g. determine that no near end extensions are off hook, send a dtmf ACK signal to the Central Office, receive FSK Caller ID data stream, etc.

Note that the 50ms monitoring period of the CONFIRM\_QUIET state when added to the 0.5 to 10ms de-response time of the FX602 in Tone Alert Detect mode and the 0 to 5ms delay in switching to FSK mode results in a valid CAS detection occurring at between 50 and 65 ms after the end of the CAS, leaving at least 35ms for muting the local handset fully, testing for off-hook extensions and initiating the dtmf ACK transmission while still meeting the 100ms specified for CIDCW from end of the dual-tone burst to the start of the ACK. See also note 3 below.

When the transaction has been completed then remove speech muting, reset the timer, set the FX602 to Tone Alert Detect mode and return to the INITIAL state.

## 6. WAIT\_DET\_LOW state

This state is entered from the MEAS\_DET\_HIGH state when the FX602 DET output has been high for 65ms i.e. for too long to be a valid CAS.

Wait for the DET output to go low then reset the timer and return to the INITIAL state.

### Times T1, T2 & T3

The values given below have been selected to give an extremely low incidence of false CAS detections while maintaining a high probability of decoding correct CIDCW initiation signals by taking advantage of the specific profile of FX602's responses to typical speech and CAS signals. Two options are given, the choice being determined principally by how easily the local speech can be muted.

- a) When the CIDCW circuits are built into the telephone set so that locally generated speech can be muted quickly and without injecting noise then it is recommended that:

T1 should be zero, i.e. muting should be initiated as soon as the FX602 DET output goes high.

T2, the time for local speech muting to take effect, should be as short as possible and in any case not more than 5ms.

T3, the minimum length of a valid DET output high time, should be 15ms.

- b) When the CIDCW circuits are housed in an adjunct box so that muting is only possible by interrupting the 2-wire connection to the telephone set, then it is recommended that:

T1 should be 15ms i.e. speech muting should only be initiated after the DET output has been high for 15ms.

T2, the time for speech muting to take effect, should be as short as possible and in any case not more than 5ms.

T3, the minimum length of a valid DET output high time, should be equal to T1 plus T2 plus 10ms, i.e. between 25 and 30ms.

Option (b) reduces the frequency of short speech mutes by a factor of about 5 at the expense of a small increase in the number of missed CAS signals.

**Notes:**

1. When the FX602 is in Tone Alert Detect mode, the IRQN output will go low on the first high to low transition of the DET output and will remain low until the FX602 is switched to FSK or Zero Power mode. Accordingly the IRQN output should be ignored when looking for a CAS signal.
2. The task of monitoring the FX602's DET output during the CONFIRM\_QUIET state may be eased by noting that in FSK Receive mode any high pulses on the DET output will last for at least 8ms (or until the mode is changed) so the signal need only be monitored more frequently than once every 8ms.
3. The actual duration of the '50ms' monitoring period is not critical but should be at least 30ms to allow time for the FSK level detector to respond.

**Timing Diagrams**

Figures 9d to 9g illustrate the CIDCW transaction initiation sequence for various cases.

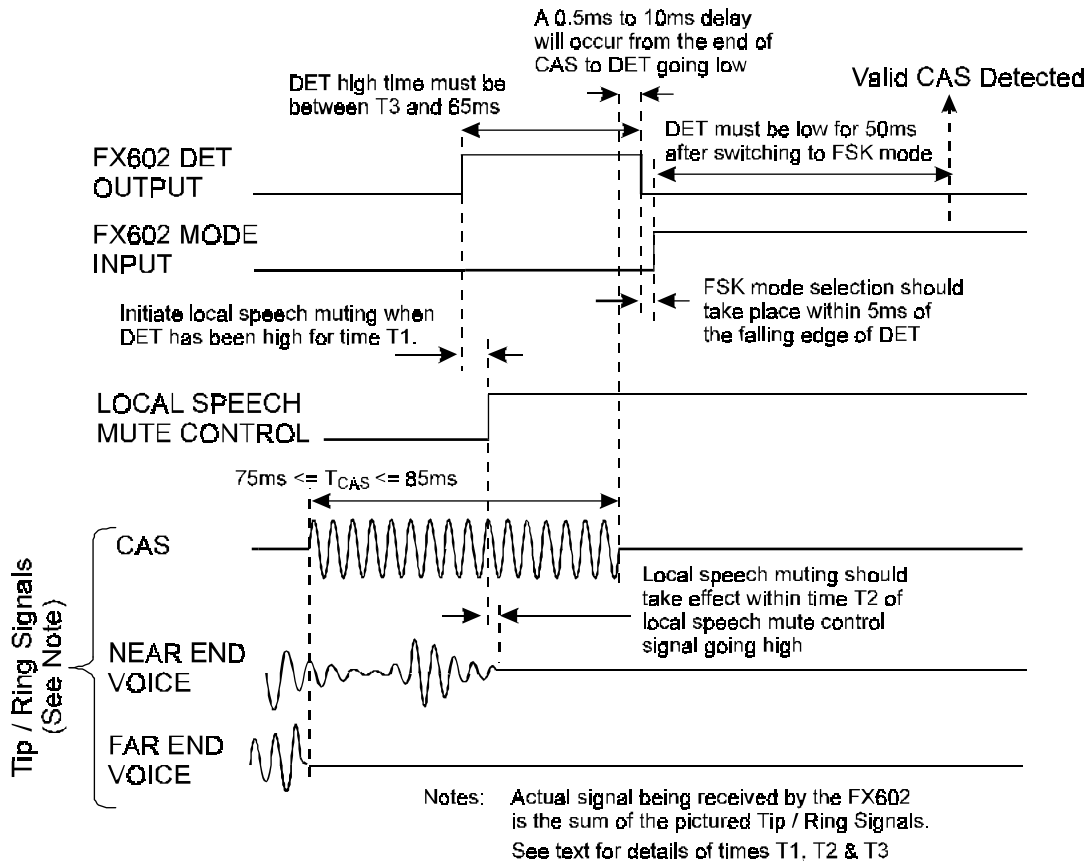

**Figure 9d : Valid CIDCW Transaction Initiation Sequence**

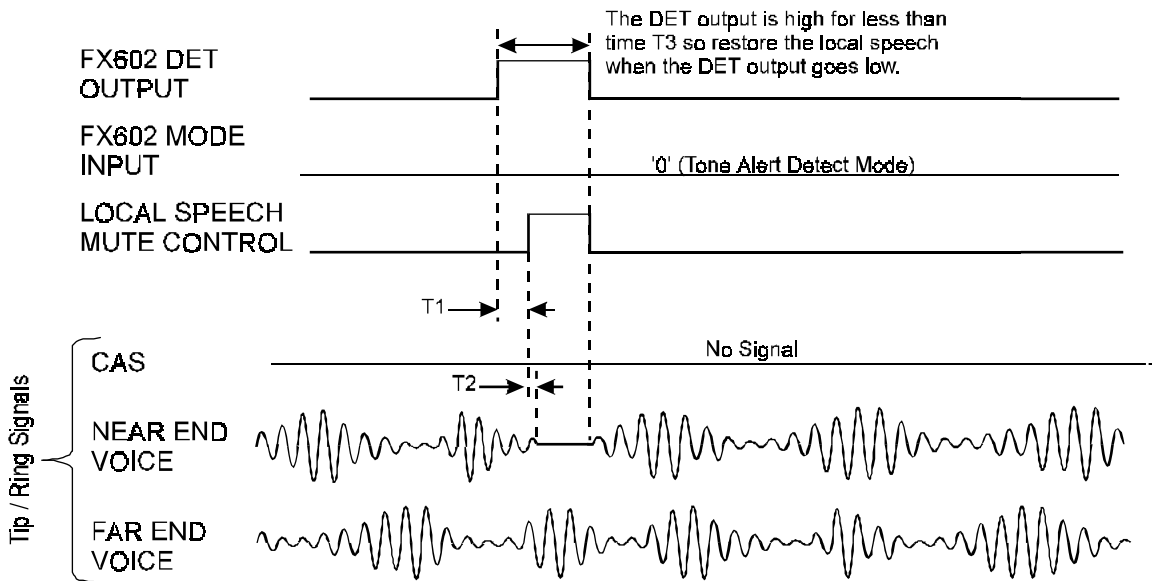

**Figure 9e : Invalid CIDCW Transaction Initiation Sequence (DET Output high for less than time  $T_3$ )**

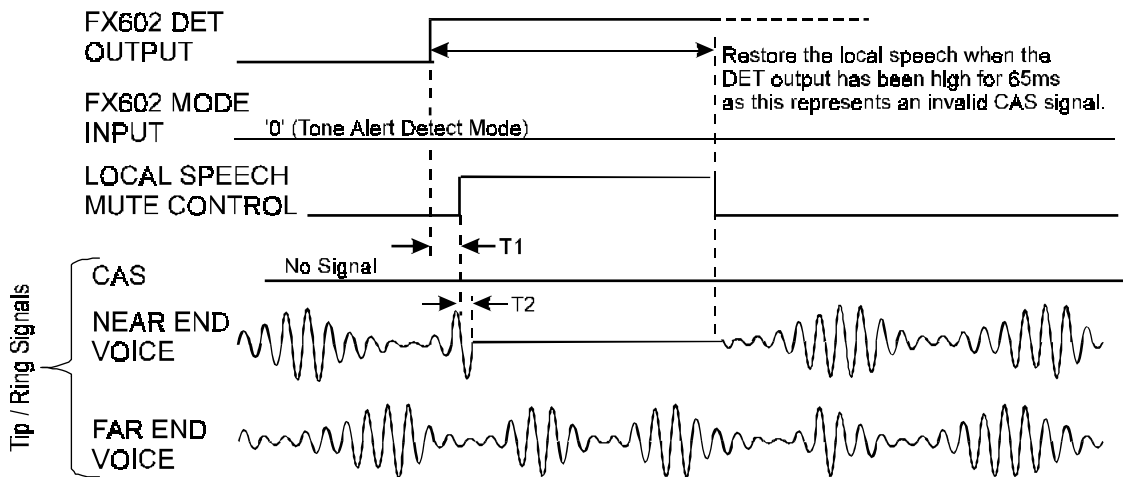

**Figure 9f : Invalid CIDCW Transaction Initiation Sequence (DET Output high for more than 65ms)**

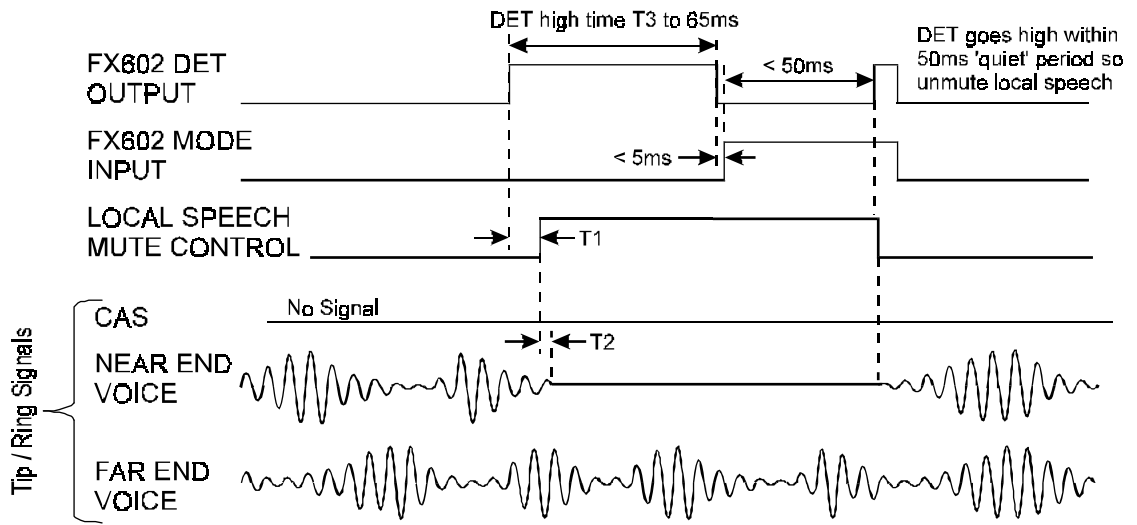

**Figure 9g : Invalid CIDCW Transaction Initiation Sequence  
(DET Output goes high during 50ms 'quiet' period)**

## 1.7 Performance Specification

### 1.7.1 Electrical Performance

#### Absolute Maximum Ratings

Exceeding these maximum ratings can result in damage to the device.

	Min.	Max.	Units
Supply ( $V_{DD} - V_{SS}$ )	-0.3	7.0	V
Voltage on any pin to $V_{SS}$	-0.3	$V_{DD} + 0.3$	V
Current into or out of $V_{DD}$ and $V_{SS}$ pins	-30	+30	mA
Current into or out of any other pin	-20	+20	mA

D4 / P3 Packages	Min.	Max.	Units
Total Allowable Power Dissipation at $T_{amb} = 25^{\circ}\text{C}$		800	mW
... Derating		13	mW/ $^{\circ}\text{C}$
Storage Temperature	-55	+125	$^{\circ}\text{C}$
Operating Temperature	-40	+85	$^{\circ}\text{C}$

#### Operating Limits

Correct operation of the device outside these limits is not implied.

	Notes	Min.	Max.	Units
Supply ( $V_{DD} - V_{SS}$ )		3.0	5.5	V
Operating Temperature		-40	+85	$^{\circ}\text{C}$
Xtal frequency	1	3.575965	3.583125	MHz

**Notes:** 1. A Xtal frequency of 3.579545MHz  $\pm$ 0.1% is required for correct Tone Alert and FSK detection.



## Operating Characteristics

For the following conditions unless otherwise specified:

$V_{DD} = 3.0V$  at  $T_{amb} = 25^{\circ}C$  and  $V_{DD} = 3.3V$  to  $5.5V$  at  $T_{amb} = -40$  to  $+85^{\circ}C$ ,

Xtal Frequency =  $3.579545MHz \pm 0.1\%$

0dBV corresponds to 1.0Vrms

	Notes	Min.	Typ.	Max.	Units
<b>DC Parameters</b>					
$I_{DD}$ (ZP input high) at $V_{DD} = 5.0V$	1,2			1.0	$\mu A$
$I_{DD}$ (ZP input low) at $V_{DD} = 3.0V$	1		0.5	1.0	$m A$
$I_{DD}$ (ZP input low) at $V_{DD} = 5.0V$	1		1.0	2.0	$m A$
Logic '1' input level (RXCK and XTAL inputs)		70%			$V_{DD}$
Logic '0' input level (RXCK and XTAL inputs)				30%	$V_{DD}$
Logic input leakage current ( $V_{in} = 0$ to $V_{DD}$ ), excluding XTAL input		-1.0		+1.0	$\mu A$
Output logic '1' level ( $I_{OH} = 360\mu A$ )		$V_{DD} - 0.4$			V
Output logic '0' level ( $I_{OL} = 360\mu A$ )				0.4	V
IRQN o/p 'off' state current ( $V_{out} = V_{DD}$ )				1.0	$\mu A$
<b>Schmitt Trigger input thresholds, see fig 10</b>					
High going ( $V_{thi}$ )		$0.56V_{DD}$		$0.56V_{DD} + 0.6$	V
Low going ( $V_{tlo}$ )		$0.44V_{DD} - 0.6$		$0.44V_{DD}$	V
<b>Tone Alert Detector</b>					
'Low' tone nominal frequency			2130		Hz
'High' tone nominal frequency			2750		Hz
Start of Tone Alert signal to DET high time (Fig. 6 Tton)			40		msec
End of Tone Alert signal to DET and IRQN low time (Fig 6 Ttoff)		0.5		10.0	msec
<b>To ensure detection ;</b>					
'Low' tone frequency tolerance	3			$\pm 20$	Hz
'High' tone frequency tolerance				$\pm 30$	Hz
Level (total)	4	-40.0		-2.2	dBV
2750Hz tone level wrt 2130Hz tone level		-7.0		+7.0	dB
Signal to Noise ratio	5	20.0			dB
Dual tone burst duration		75			msec
<b>To ensure non-detection ;</b>					
'Low' tone frequency tolerance	6	$\pm 75$			Hz
'High' tone frequency tolerance		$\pm 95$			Hz
Level (total)	4			-46.0	dBV
Dual tone burst duration				25	msec

	Notes	Min.	Typ.	Max.	Units
<b>FSK Receiver</b>					
Transmission rate		1188	1200	1212	Baud
V23 Mark (logical 1) frequency		1280	1300	1320	Hz
V23 Space (logical 0) frequency		2068	2100	2132	Hz
Bell202 Mark (logical 1) frequency		1188	1200	1212	Hz
Bell202 Space (logical 0) frequency		2178	2200	2222	Hz
Valid input level range	4	-40.0		-8.0	dBV
Acceptable twist (mark level wrt space level)					
V23		-7.0		+7.0	dB
Bell202		-10.0		+10.0	dB
Acceptable Signal to Noise ratio					
V23	5	20.0			dB
Bell202	5	30.0			dB
Level Detector 'on' threshold level	4			-40.0	dBV
Level Detector 'off' to 'on' time (Fig 4 Teon)				25.0	msec
Level Detector 'on' to 'off' time (Fig 4 Teoff)		8.0			msec
<b>Input Signal Amplifier</b>					
Input impedance	7	10.0			M $\Omega$
Voltage gain			500		V/V
<b>XTAL Input</b>					
'High' pulse width	8	100			ns
'Low' pulse width	8	100			ns

- Notes:**
1. At 25°C, not including any current drawn from the FX602 pins by external circuitry other than X1, C1 and C2.
  2. RD, MODE, RXCK inputs at  $V_{SS}$ , ZP input at  $V_{DD}$ . See also Figure 11.
  3. All conditions must be met to ensure detection.
  4. For  $V_{DD}$  = 5.0V with equal level tones and with the input signal amplifier external components as section 1.4. The internal threshold levels are proportional to  $V_{DD}$ . To cater for other supply voltages or different signal level ranges the voltage gain of the input signal amplifier should be adjusted by selecting the appropriate external components as described in section 1.5
  5. Flat noise in 300-3400Hz band for V23, 200 - 3200Hz for Bell202.
  6. Meeting any of these conditions will ensure non-detection.
  7. Open loop, small signal low frequency measurements.
  8. Timing for an external input to the CLOCK/XTAL pin.

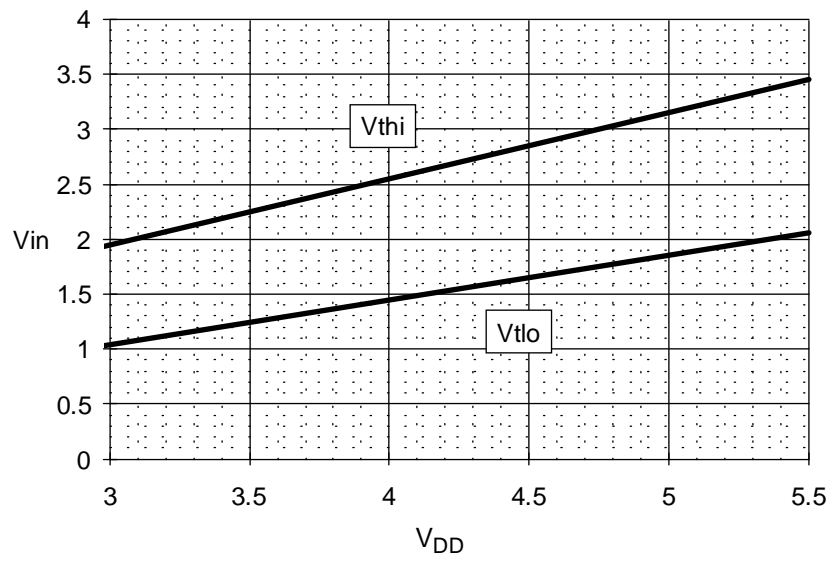

Figure 10 : Schmitt Trigger typical input voltage thresholds vs. V<sub>DD</sub>

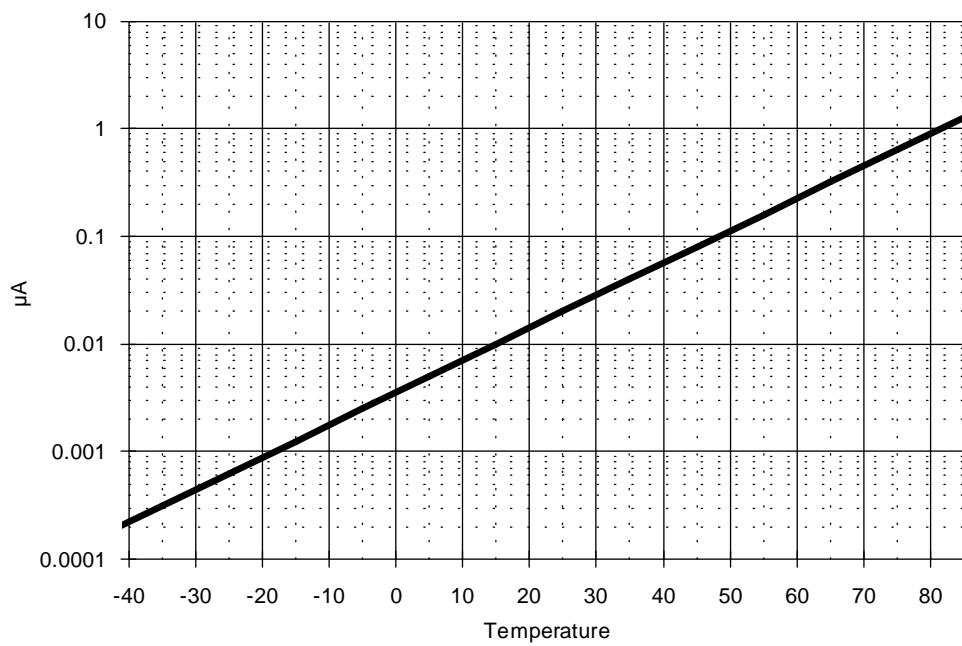

Figure 11 : Typical 'Zero Power' I<sub>DD</sub> vs. Temperature (V<sub>DD</sub> = 5.0V)

1.7.2 Packaging

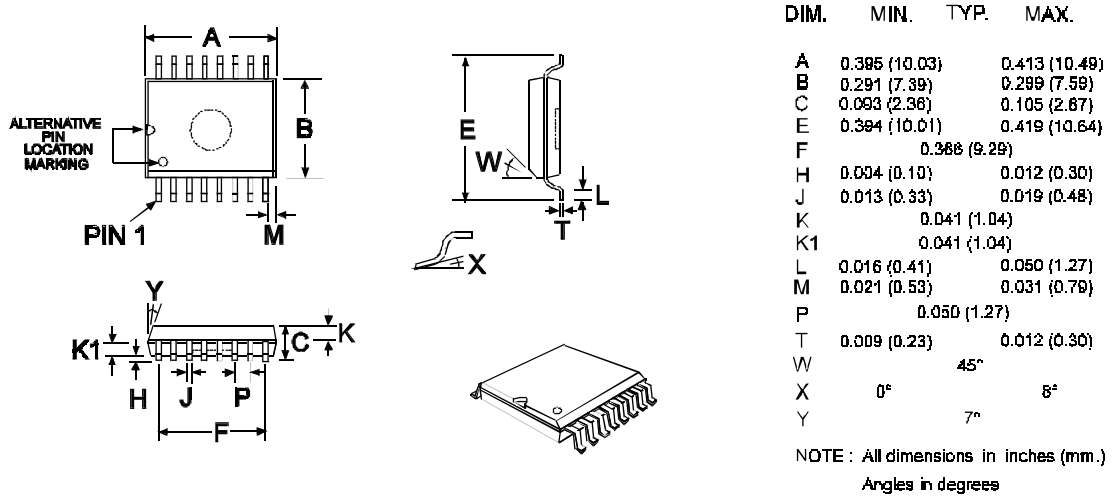

Figure 12 : 16-pin SOIC (D4) Mechanical Outline: *Order as part no. FX602D4*

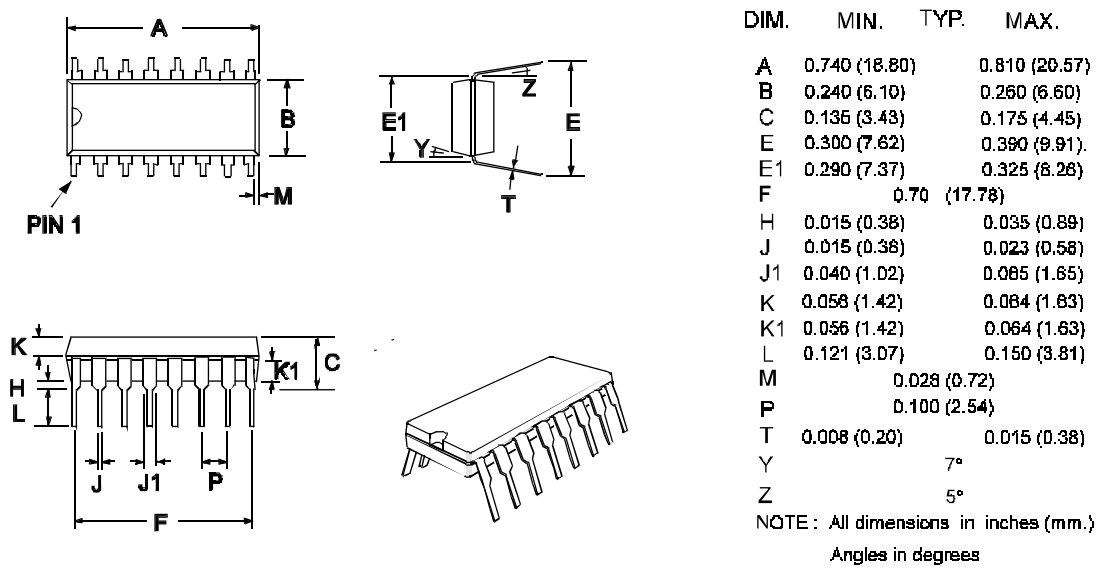

Figure 13 : 16-pin DIL (P3) Mechanical Outline: *Order as part no. FX602P3*

Handling precautions: This product includes input protection, however, precautions should be taken to prevent device damage from electro-static discharge. CML does not assume any responsibility for the use of any circuitry described. No IPR or circuit patent licences are implied. CML reserves the right at any time without notice to change the said circuitry and this product specification. CML has a policy of testing every product shipped using calibrated test equipment to ensure compliance with this product specification. Specific testing of all circuit parameters is not necessarily performed.



**CONSUMER MICROCIRCUITS LIMITED**

1 WHEATON ROAD  
WITHAM - ESSEX CM8 3TD - ENGLAND

Telephone: +44 1376 513833  
Telefax: +44 1376 518247