

Antenna Accessories for the Beginner

Basic Amateur Radio: How many antenna gadgets are needed to put out a good signal? Perhaps your station is overequipped, or maybe you've been shortchanging yourself on accessories. Here are some helpful tips.

By Doug DeMaw,* W1FB

If you're new to Amateur Radio, you've probably been wondering why there are so many gimmicks advertised for use with an antenna system. The ads in the ham magazines show all manner of gadgets that you "should" purchase to ensure maximum results with your antenna, no matter what kind of radiator you may be using. As you study the ads and listen to the recommendations of other amateurs, you may find yourself floating in a sea of dollar signs and wondering why all of those expensive items are so necessary to the health and welfare of your 80-meter dipole. Should you have a balun? Do you need an SWR indicator? Is it really necessary to use a Transmatch (or antenna tuner, as it is sometimes called)?

There is a certain mystique about antennas that makes them fun to experiment with. Almost any amateur wants to know as much as he can about antennas, and as a rule they aren't too expensive to play with. Accessory equipment is useful for experimenting and solving antenna problems, but it is sometimes a luxury that one can do without quite handily. Let's look at the various items that are thrown out to hams as lures for better DX results. That oracle you've been listening to on your favorite amateur band may be nothing more than a "walking encyclopedia of technical misinformation." It could be that no matter how many times you read the ads for antenna accessories, you don't comprehend the benefits offered by the seller. This article is aimed at those who are a bit confused by all this. After you

read this presentation, you should be able to make your own judgments concerning what you need or don't need.

Baluns — Are They Necessary?

First of all, what in the heck is a balun? It's a word that is frequently mispronounced, and that adds to the confusion. Correct pronunciation is "bal'un" (like *bal* in balanced and *un* in unbalanced. That is exactly what the word means — *balanced to unbalanced*. Some call them, incorrectly, "bal-oons" or "ballums."

A balun is used to change a balanced condition to an unbalanced one at some low value of impedance. A balun transformer can also be used to change a low impedance to a higher one in a system, while at the same time converting an unbalanced condition to a balanced one. For example, a half-wavelength dipole for 40 meters is a balanced antenna at the feed point, and if one were to use

Fig. 1 — A theoretically correct radiation pattern for a half-wavelength dipole (A), and one that has a pattern skew caused by an imbalance in the feed system (B).

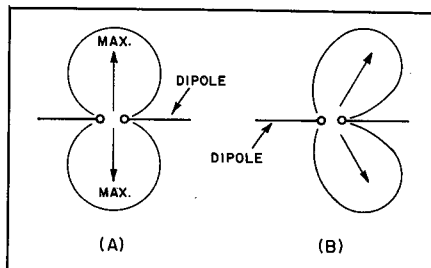

*Senior Technical Editor, ARRL

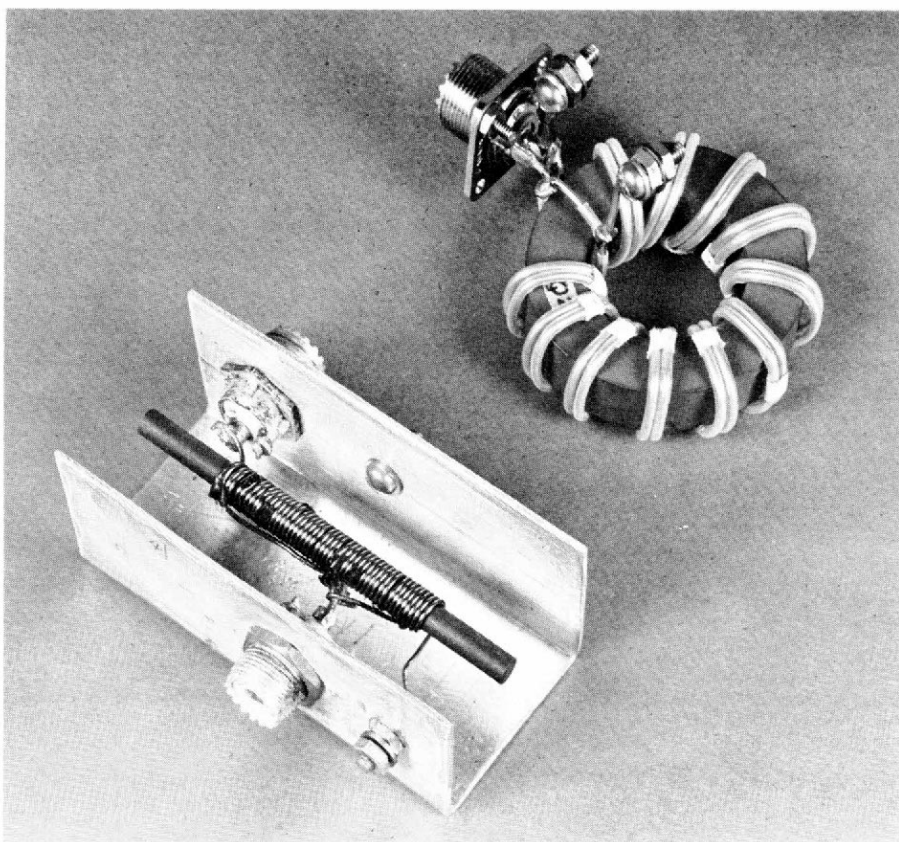

Broadband transformers of the type used as baluns. The model on the left is solenoidal. At the right is a toroidal transformer. (photo courtesy of W2FM1)

72-ohm twin-lead as the feeder, the entire system down to the station would be balanced. In theory, this would lead to a radiation pattern from the antenna that was uniform in both directions off the broad side of the dipole. However, if 72-ohm coaxial feed line were used, as is the typical case, there could be a slight skew in the radiation pattern (it would be slightly lopsided). This could result from using an unbalanced feeder with a balanced dipole. Fig. 1 illustrates this principle. Assume that you are high above your dipole looking down at it and that you sprayed the rf energy with some magical green paint so you could see the path it was taking as it left the dipole. At Fig. 1A, illustrating use of twin-lead, you would view a clean lobe off each side of the antenna. As shown at B, there could be a distorted pattern. The latter would result from unwanted radiation from the feed line, caused by the imbalance of a coaxial-cable antenna feeder.

At this point it might be proper to say, "So what?" In practice, pattern skewing will never be noticed, and the transmitter and receiver couldn't care less. A slight lobe distortion makes little difference, since dipoles, when used by themselves, do not have a sharp directivity pattern (narrow lobe). In any case, a dipole won't exhibit its normal radiation pattern unless it is well removed from conductive objects

(power lines, gutter pipes and the like).

Provision for balanced feed to a dipole is important, however, when the dipole is part of a high-gain directive beam antenna, such as a multielement Yagi. The latter will exhibit a fairly sharp pattern in the forward direction, and in order to establish useful beam headings in DX work the pattern should be as distortion-free as possible. This enables the operator to get maximum signal headed in the desired direction. In a stacked array, two or more beams in a combination, it is important to maintain a balanced condition in the harnessing (connecting cables) of the bays. This will help prevent unwanted radiation from the harnessing system. Such radiation could easily spoil the radiation pattern of the beam array, especially in vhf and uhf antenna systems. Balance is difficult to achieve in the latter case.

Are Baluns Black Magic?

Because there is so much antenna nonsense going on these days, a beginner can be misled easily. Just consider the weird TV and fm antennas that you see advertised, or for that matter, the absurd claims being made about some CB antennas! The more spikes, spears and prongs protruding from the booms of commercial TV and fm antennas, the greater the claims made by the manufacturer, and the higher the cost. Many of these antennas

defy technical explanation, and are in fact contrary to all antenna theory. Yet, the unsuspecting buyer can succumb to the sales pitch and get "ripped off." Fortunately, this doesn't happen in most of the ads which appear in Amateur Radio magazines and journals. But, there are still some subtle areas of confusion which can cause an amateur to spend his money for something he doesn't really need. The balun transformer sometimes falls into that classification despite the upright intentions of those who sell the product. It's more a matter of insufficient information than one of false claims.

A balun is supposed to be a broadband device. That is, it is manufactured for a particular feed-line impedance, and should be suitable for use from, say, 1.8 to 30 MHz in a typical case. This means that it should not be reactive when it is inserted in a feeder system. But, few baluns satisfy that basic requirement, as observed during some ARRL laboratory tests that were performed on a group of homemade and commercial amateur baluns. The units tested were built on ferrite and powdered-iron cores. Some of the cores were toroidal and others were solenoidal (doughnuts or rods). The baluns were terminated in resistive loads of their rated values, connected to a laboratory-grade RX meter (reactance bridge), and tested in the center of each amateur band for which they were designed. None were flat (zero reactance) in all of the amateur bands from 1.8 to 29.7 MHz. In fact, some were not flat in *any* amateur band! With the latter, the flatness was found at some frequency outside the amateur bands!

There are two important points to consider here. First, a balun transformer is not simply a collection of wire turns placed on a piece of core material. The design rules are fairly rigid if proper wide-band characteristics are to be obtained.¹ Second, a poorly designed balun can ruin an antenna system rather than improve it. If it is highly reactive, as some seem to be, it can cause an SWR (standing-wave ratio) which is higher than that which existed at antenna resonance before the balun was connected in the line! Just the opposite effect can occur when the system is operated at a frequency away from antenna resonance. Most transformer baluns behave as true baluns only when they "look into" a purely resistive load. Off resonance, where the load on the balun is reactive, core losses in the balun increase and therefore reflected power decreases. This means the SWR in the line is lower than without the balun, giving you a false indication that your antenna system is broad in terms of frequency range.

A balun transformer is useful when an impedance transformation is desired between an antenna feed point and an unbalanced feeder of lower impedance. An

¹Notes appear on page 19.

example of this can be seen in Fig. 2 — a 300-ohm folded dipole is fed with 75-ohm coaxial cable. The balun effects a 4:1 impedance transformation *and* converts a balanced condition to an unbalanced one. The same balun could be used to convert a 200-ohm feed-point impedance to 50 ohms, unbalanced. It is desirable to provide the transmitter and receiver with a 50- or 75-ohm unbalanced feeder because most modern amateur equipment is designed to look into that type of transmission line.

Whether or not you need a balun in your antenna system will depend on what you're attempting to accomplish with the system. When it comes to an ordinary half-wavelength dipole for the high-frequency bands, direct coaxial-cable feed will be adequate if the antenna is adjusted for a low SWR. A balun won't give you an increase in radiated power, and that's important to know. If you do purchase a balun, ask the manufacturer to assure you that his unit is *really a balun* at all of the frequencies he specifies — not a reactive device that might degrade your antenna system.

Should You Buy and Use an SWR Indicator?

SWR indicators are known by a lot of names, such as SWR bridge, rf power meter, Monimatch, Bruene bridge, Micro-match and others. Some instruments are built to read forward and reflected power in watts, while others simply indicate when a matched antenna condition is reached (minimum reflected energy, as shown on a meter). SWR indicators come in a variety of sizes, styles and price classes, but fundamentally they serve the same purpose: They help the amateur keep tabs on the condition of his antenna system.

Too much emphasis is placed on acquiring and maintaining an SWR of 1 (1:1 match). In bygone days many amateurs adjusted their antennas for proper performance by a very simple means: They tuned the last stage of the transmitter (loading and plate-tuning controls) for a dip and the desired amount of loading by attaching a nonreactive 50-ohm dummy load to the transmitter output. The dial settings were noted, then the antenna was

Fig. 2 — A balanced, 300-ohm, half-wave dipole can be fed with 75-ohm unbalanced line (coax) by installing a 4:1 balun transformer directly at the feed point.

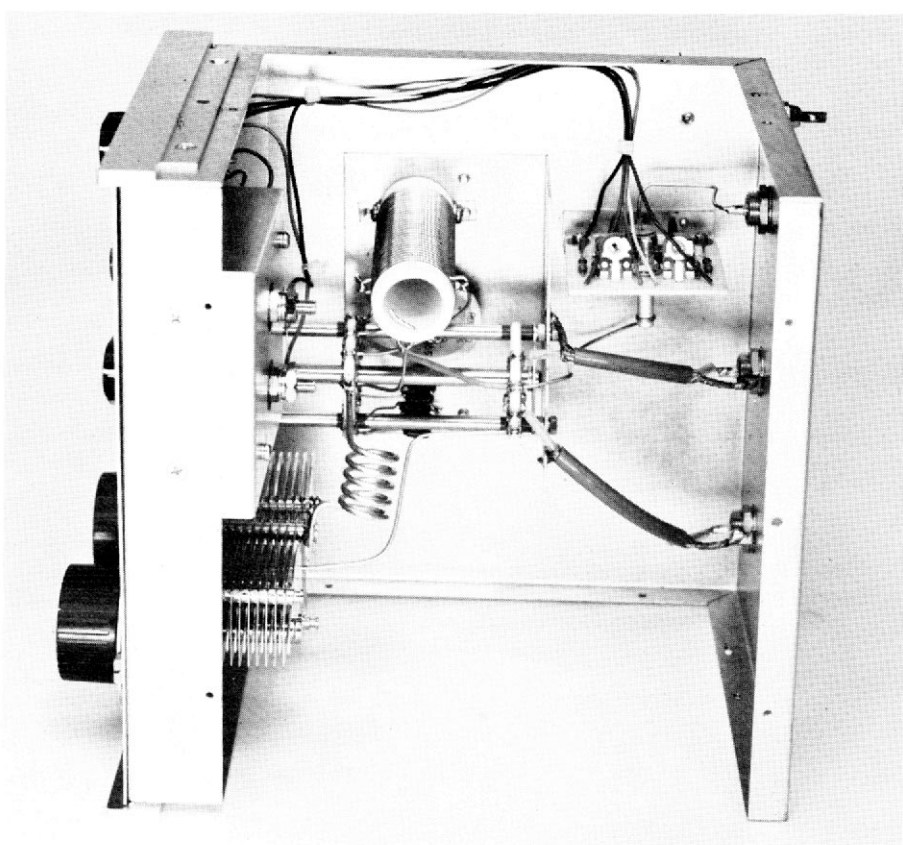
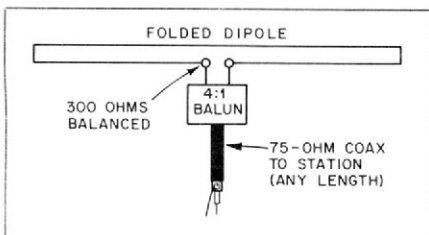

Interior view of a medium-power commercially built Transmatch. The unit shown is a Leader LAC-895. SWR-indicator circuitry is visible at the upper right. The coils and capacitors for the tuning network are at the left, along with a band switch (left center).

connected to the transmitter. Antenna adjustments were made until the final-amplifier dial settings, with proper tuning and loading, were the same as when the dummy load was connected. This resulted in an SWR of 1, or nearly so.

Nowadays, our ham shacks are filled with gadgets that are helpful, but not always necessary. An SWR indicator will speed antenna adjustments, especially if a Transmatch is used in the line. For that reason they are probably worth owning. An SWR instrument is designed for a particular line impedance, usually 50 or 75 ohms, but not both. If the readings are to be meaningful, the indicator should be designed for the line impedance being used.

It is not unusual to hear a conversation on the air during which one operator will suddenly exclaim, "Oh my goodness, I see that my SWR is up to 1.8 to 1. Stand by until I readjust things." Finally, after he obtains an SWR of 1, he can be heard to say, "There, OM, things are back to normal. How much did my signal increase?" Assuming that his transmitter was capable of loading to full power with the slight mismatch he had, his signal strength would not change by an apparent amount; the entire exercise was one of futility. But SWR indicators have brought on a form of paranoia among some amateurs, and SWR ranks high as a topic of conversa-

tion in our amateur bands. Admittedly, it is psychologically satisfying to attack one's favorite ham band with an SWR of 1, but it's not a necessity if the transmitter doesn't object to working into a minor mismatch. Most rigs that have pi networks in the output are capable of being adjusted for proper operation when looking into loads from approximately 40 to 100 ohms. So if the SWR isn't perfect, it will not matter. You'll get out just as well as would be possible with a perfect match.

An SWR indicator is of little use when coaxial-cable fed dipoles are in use, or when coax feed is used with beam antennas that were adjusted properly at the time of installation. Sure, the indicator will help you keep an eye on the condition of the antenna, but if anything goes wrong you'll know it without watching an SWR meter: Your transmitter loading will change, and you'll be aware that something has gone amiss!

The most useful application of an SWR indicator is realized during initial adjustments of an antenna. For example, the instrument is placed in the feed line, switched to read reflected energy, and monitored as the length of the driven element (a simple dipole) or the matching section of a beam (gamma match, T match or whatever) is adjusted for the lowest SWR in the chosen part of the band. It is entirely possible that an SWR

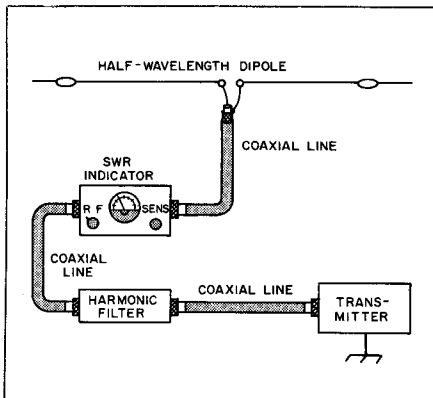

Fig. 3 — Harmonic energy from the transmitter can cause a false SWR reading. Installation of a harmonic filter, as shown here, can correct the problem.

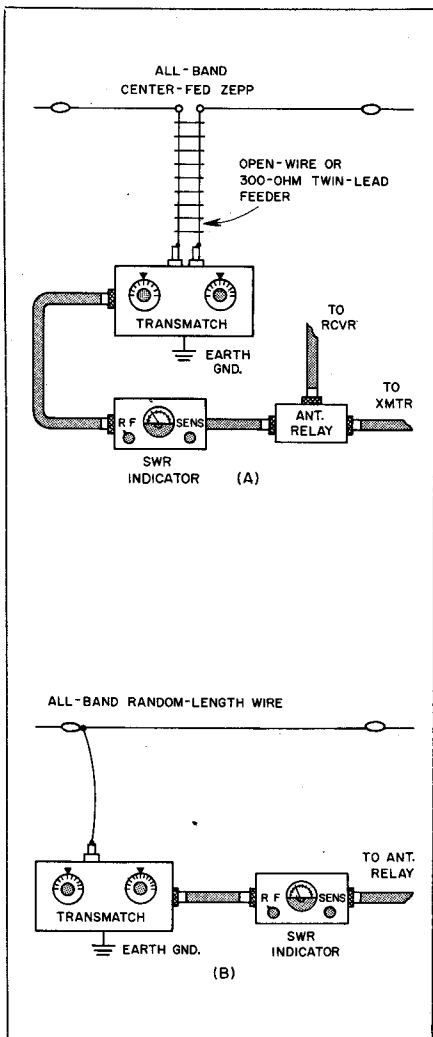

Fig. 4 — A Transmatch can be justified when it is necessary to use the same dipole on several amateur bands. The example at A shows a Transmatch connected to balanced feeders which supply power to a center-fed Zepp antenna. At B, we have a random-length wire being matched to the transmitter by means of a Transmatch to provide multiband operation. An effective earth ground is necessary to reduce the effects of rf appearing on the station equipment.

of 1 will not be obtained when adjusting the overall length of a half-wavelength dipole if a 50- or 75-ohm feed line is used. The actual feed-point impedance will depend on the height of the dipole above ground, as well as its length. However, a close enough match will be attainable, consistent with good transmitter performance — a 2:1 SWR or better in the usual case.² These same statements apply to the inverted-V dipole, the enclosed angle of which will also affect the impedance.

If the transmitter has an appreciable amount of harmonic energy in the output, false SWR readings may result. This is because the antenna will not accept the harmonics, and they will register as reflected energy on the meter, even though the antenna may be matched perfectly at the desired operating frequency. By inserting a harmonic filter in the feed line between the SWR indicator and the transmitter, false readings can be eliminated.³ The filter should have the same impedance characteristic as the transmission line. That is, a 50-ohm filter belongs in a 50-ohm line, and a 75-ohm filter should be used in a 75-ohm line. A suggested hookup is shown in Fig. 3. The references at the end of this article should be useful to those who want to build an SWR indicator.

The Transmatch Syndrome

Here's another ham-shack device that has a host of names. These antenna matching networks are called antenna couplers, antenna tuners and Transmatches. The right name will depend on what is being done with the equipment. If one of these coil-capacitor networks is used at the feed point of the antenna (and some antennas, such as random-length wires, are brought right into the shack), then *antenna tuner* might be a proper title for the device. If the unit is used at the transmitter to tune an overall antenna system (radiator and its feeder) to resonance, Transmatch is a more suitable name for it. The latter signifies "matching the transmitter to the line."

A Transmatch is a network that is used to correct — as far as the transmitter is concerned — a poorly matched antenna. Since the proper place to correct the mismatch is at the feed point of the antenna, the best a Transmatch can do is make the antenna system look like 50 or 75 ohms at the rig. Let's suppose that some lazy amateur precut an 80-meter, coax-fed dipole, erected it, then discovered by means of an indicator that it had an SWR of 5:1. Being afflicted with chronic lassitude, he refused to take it down and prune it for a low SWR. Meanwhile, his transmitter "hated" what it was forced to look into, refusing to load up. Lazy Joe's answer to his misfortune was to place a Transmatch at the transmitter output, then adjust it so the rig could work into a 50-ohm load. This made everything

"hunky dory," and Joe went on his happy way calling CQ. However, the mismatch remained between the line and the antenna. Being inherently lazy, Joe might even elect to force-feed his 80-meter antenna on 40 meters by resorting to the Transmatch. The efficiency of the system on 40 would be poor, but Joe would be happy, and so would his transmitter.

Well, that's one use for a Transmatch. In a more realistic situation the Transmatch could be employed to extend the useful range of a single-band dipole (coax fed) across all of a band. A typical half-wavelength dipole will exhibit a low SWR at only the part of the band for which it has been adjusted. This is true especially on 80 and 160 meters, the widest amateur bands we have in terms of change in frequency percentage. Typically, the amateur cuts his dipole for the favored part of a band, then does the best he can in other portions of the band, as the SWR rises rapidly when the operating frequency is moved above or below the resonant frequency of the antenna. A Transmatch will enable the transmitter to load correctly across all of a given band. The principal danger in operating an antenna with high SWR through a Transmatch is that, depending on the power being used, the high standing waves can cause high rf voltage. This can result in feed-line breakdown and, under extreme conditions, arcing in the Transmatch components (switches and variable capacitors). The Transmatch or the feed line could be damaged seriously. Needless to say, Transmatches can be used in this manner with any type of antenna system — dipoles, verticals or beams.

When to Use a Transmatch

There is justification for the expense of a homemade or store-bought Transmatch in the case of all-band antennas which have a single feeder of some specified characteristic. Here, we are considering an end- or center-fed Zepp type of antenna, or some end-fed, single-wire radiator. Fig. 4 illustrates the application under discussion.

It seems that the lesson to be learned here is that it is uneconomical to buy a Transmatch merely because most well-equipped stations seem to have one or more of the things. One might equate this to installing an air conditioner in a car used by a resident of Alaska. It might be neat to have one for occasional use, but how often would it really be put to practical use?

In Summary

It isn't necessary to clutter the operating position with gadgets unless there is a specific need for them. The decision is yours to make, but chances are that you can do a fine job of shooting that signal out to distant points without baluns, SWR meters and Transmatches.

Using coaxial-line feed for a group of dipoles, cutting the antennas according to the formula, length in feet = $468/f$ in MHz, then mounting the dipoles well in the clear of conductive objects, should assure good performance. You won't have to invest in an assortment of things that are seen in other shacks.

If you plan to be an experimenter, then we're addressing ourselves to an entirely different matter. Development work can't be done easily without test equipment and accessory items that play an important role in making antennas do what you want them to. *The ARRL Antenna Book* contains descriptions of numerous antennas that don't require the accessories we have

discussed in this article. You may want to study this publication before you equip your station with antennas and related apparatus. 

Notes

¹Broadband transformer design is treated in the *ARRL Electronics Data Book*.

²The effects of height versus feed impedance are covered in *The ARRL Antenna Book*.

³Half-wave harmonic filters for 50- and 75-ohm lines are described in the *ARRL Electronics Data Book*.

References

Transmatches

DeMaw, "A Poor Ham's QRP Transmatch," *QST*, October 1973.

McCoy, "A Versatile Transmatch," *QST*, July 1965.

McCoy, "A Transmatch for Balanced and Unbalanced Feeders," *QST*, October 1966.

McCoy, "Why a Transmatch?" *QST*, January 1968.

McCoy, "The Ultimate Transmatch," *QST*, July 1970.

McCoy, "Some Plain Facts About Antennas, Feeders and Transmatches," *QST*, May 1971.

SWR and RF Power Indicators

Bruene, "Directional Wattmeters," *QST*, April 1959.

DeMaw, "In-Line RF Power Metering," *QST*, December 1969.

McCoy, "The Monimatch," *QST*, October 1956.

McCoy, "The Monimatch Mark II," *QST*, February 1957.

McCoy, "Meet the SWR Bridge," *QST*, March 1955.

McCoy, "The Millimatch," *QST*, August 1967.

McMullen, "The Line Sampler," *QST*, April 1972.

Baluns

McCoy, "Is a Balun Required?" *QST*, December 1968.

Turrin, "Balun Transformers," *QST*, April 1969.

The Radio Amateur's Handbook, chapter on transmission lines.